

10 Directed Graphs

10.1 DIRECTED GRAPHS

Although many problems lend themselves naturally to a graph-theoretic formulation, the concept of a graph is sometimes not quite adequate. When dealing with problems of traffic flow, for example, it is necessary to know which roads in the network are one-way, and in which direction traffic is permitted. Clearly, a graph of the network is not of much use in such a situation. What we need is a graph in which each link has an assigned orientation—a directed graph. Formally, a *directed graph* D is an ordered triple $(V(D), A(D), \psi_D)$ consisting of a nonempty set $V(D)$ of *vertices*, a set $A(D)$, disjoint from $V(D)$, of *arcs*, and an *incidence function* ψ_D that associates with each arc of D an ordered pair of (not necessarily distinct) vertices of D . If a is an arc and u and v are vertices such that $\psi_D(a) = (u, v)$, then a is said to *join* u to v ; u is the *tail* of a , and v is its *head*. For convenience, we shall abbreviate ‘directed graph’ to *digraph*. A digraph D' is a *subdigraph* of D if $V(D') \subseteq V(D)$, $A(D') \subseteq A(D)$ and $\psi_{D'}$ is the restriction of ψ_D to $A(D')$. The terminology and notation for subdigraphs is similar to that used for subgraphs.

With each digraph D we can associate a graph G on the same vertex set; corresponding to each arc of D there is an edge of G with the same ends. This graph is the *underlying graph* of D . Conversely, given any graph G , we can obtain a digraph from G by specifying, for each link, an order on its ends. Such a digraph is called an *orientation* of G .

Just as with graphs, digraphs have a simple pictorial representation. A digraph is represented by a diagram of its underlying graph together with arrows on its edges, each arrow pointing towards the head of the corresponding arc. A digraph and its underlying graph are shown in figure 10.1.

Every concept that is valid for graphs automatically applies to digraphs too. Thus the digraph of figure 10.1a is connected and has no cycle of length three because its underlying graph (figure 10.1b) has these properties. However, there are many concepts that involve the notion of orientation, and these apply only to digraphs.

A *directed walk* in D is a finite non-null sequence $W = (v_0, a_1, v_1, \dots, a_k, v_k)$, whose terms are alternately vertices and arcs, such that, for $i = 1, 2, \dots, k$, the arc a_i has head v_i and tail v_{i-1} . As with walks in graphs, a directed walk $(v_0, a_1, v_1, \dots, a_k, v_k)$ is often represented simply by

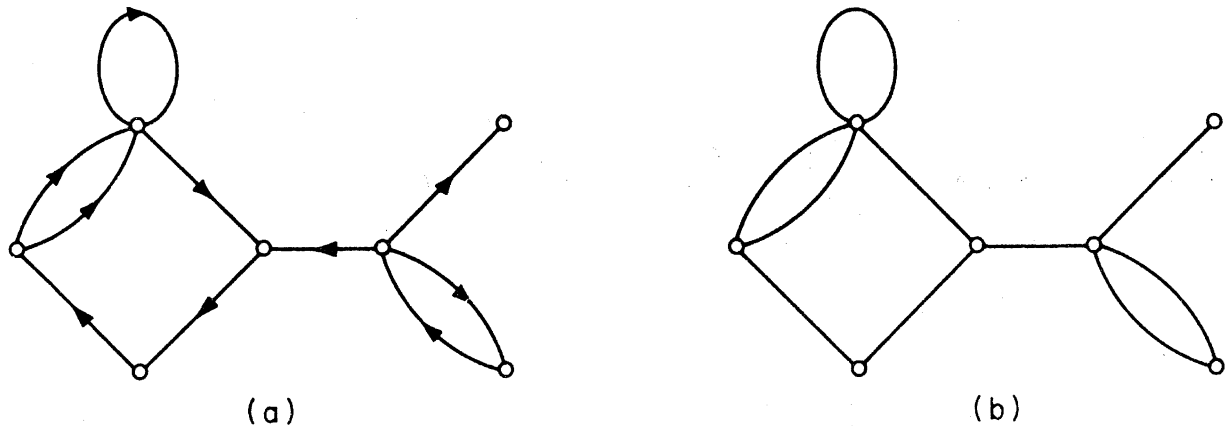

Figure 10.1. (a) A digraph D ; (b) the underlying graph of D

its vertex sequence (v_0, v_1, \dots, v_k) . A *directed trail* is a directed walk that is a trail; *directed paths*, *directed cycles* and *directed tours* are similarly defined.

If there is a directed (u, v) -path in D , vertex v is said to be *reachable* from vertex u in D . Two vertices are *disonnected* in D if each is reachable from the other. As in the case of connection in graphs, disconnection is an equivalence relation on the vertex set of D . The subdigraphs $D[V_1], D[V_2], \dots, D[V_m]$ induced by the resulting partition (V_1, V_2, \dots, V_m) of $V(D)$ are called the *diconnected components* of D . A digraph D is *disonnected* if it has exactly one diconnected component. The digraph of figure 10.2a is not disonnected; it has the three diconnected components shown in figure 10.2b.

The *indegree* $d_D^-(v)$ of a vertex v in D is the number of arcs with head v ; the *outdegree* $d_D^+(v)$ of v is the number of arcs with tail v . We denote the minimum and maximum indegrees and outdegrees in D by $\delta^-(D)$, $\Delta^-(D)$, $\delta^+(D)$ and $\Delta^+(D)$, respectively. A digraph is *strict* if it has no loops and no two arcs with the same ends have the same orientation.

Throughout this chapter, D will denote a digraph and G its underlying graph. This is a useful convention; it allows us, for example, to denote the vertex set of D by V (since $V = V(G)$), and the numbers of vertices and arcs in D by ν and ε , respectively. Also, as with graphs, we shall drop the letter D from our notation whenever possible; thus we write A for $A(D)$, $d^+(v)$ for $d_D^+(v)$, δ^- for $\delta^-(D)$, and so on.

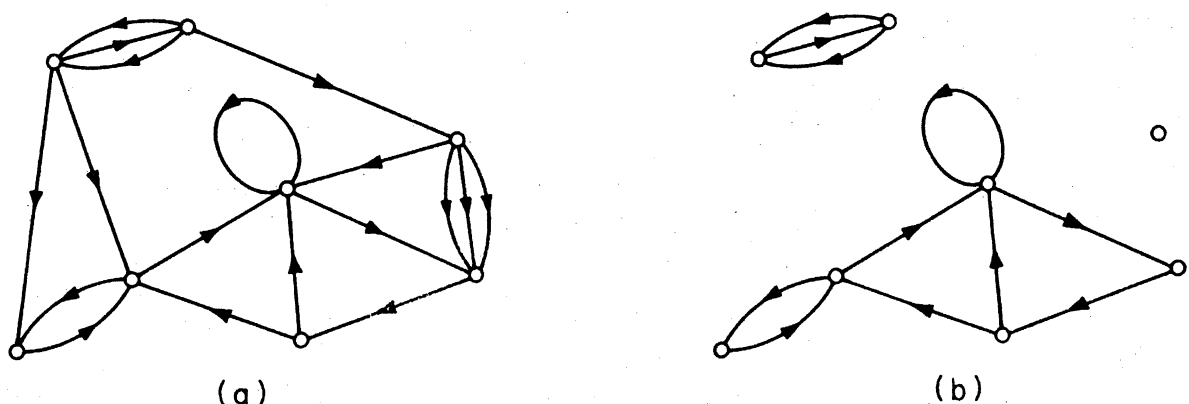

Figure 10.2. (a) A digraph D ; (b) the three diconnected components of D

Exercises

- 10.1.1 How many orientations does a simple graph G have?
- 10.1.2 Show that $\sum_{v \in V} d^-(v) = \varepsilon = \sum_{v \in V} d^+(v)$
- 10.1.3** Let D be a digraph with no directed cycle.
- Show that $\delta^- = 0$.
 - Deduce that there is an ordering v_1, v_2, \dots, v_n of V such that, for $1 \leq i \leq n$, every arc of D with head v_i has its tail in $\{v_1, v_2, \dots, v_{i-1}\}$.
- 10.1.4 Show that D is disconnected if and only if D is connected and each block of D is disconnected.
- 10.1.5 The *converse* \tilde{D} of D is the digraph obtained from D by reversing the orientation of each arc.
- Show that
 - $\tilde{\tilde{D}} = D$;
 - $d_{\tilde{D}}^+(v) = d_D^-(v)$;
 - v is reachable from u in \tilde{D} if and only if u is reachable from v in D .
 - By using part (ii) of (a), deduce from exercise 10.1.3a that if D is a digraph with no directed cycle, then $\delta^+ = 0$.
- 10.1.6 Show that if D is strict, then D contains a directed path of length at least $\max\{\delta^-, \delta^+\}$.
- 10.1.7** Show that if D is strict and $\max\{\delta^-, \delta^+\} = k > 0$, then D contains a directed cycle of length at least $k + 1$.
- 10.1.8** Let v_1, v_2, \dots, v_n be the vertices of a digraph D . The *adjacency matrix* of D is the $n \times n$ matrix $\mathbf{A} = [a_{ij}]$ in which a_{ij} is the number of arcs of D with tail v_i and head v_j . Show that the (i, j) th entry of \mathbf{A}^k is the number of directed (v_i, v_j) -walks of length k in D .
- 10.1.9** Let D_1, D_2, \dots, D_m be the dicomponents of D . The *condensation* \hat{D} of D is a directed graph with m vertices w_1, w_2, \dots, w_m ; there is an arc in \hat{D} with tail w_i and head w_j if and only if there is an arc in D with tail in D_i and head in D_j . Show that the condensation \hat{D} of D contains no directed cycle.
- 10.1.10 Show that G has an orientation D such that $|d^+(v) - d^-(v)| \leq 1$ for all $v \in V$.

10.2 DIRECTED PATHS

There is no close relationship between the lengths of paths and directed paths in a digraph. That this is so is clear from the digraph of figure 10.3, which has no directed path of length greater than one.

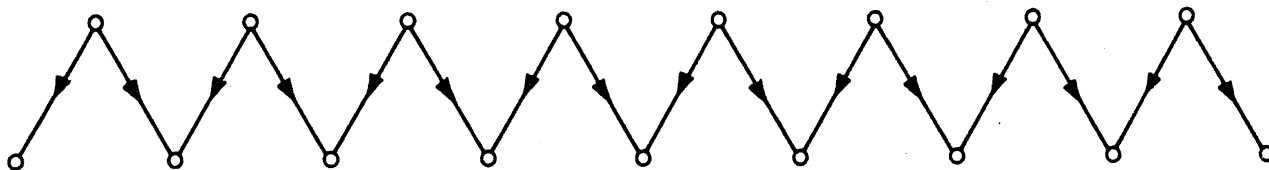

Figure 10.3

Surprisingly, some information about the lengths of directed paths in a digraph can be obtained by looking at its chromatic number. The following theorem, due to Roy (1967) and Gallai (1968), makes this precise.

Theorem 10.1 A digraph D contains a directed path of length $\chi - 1$.

Proof Let A' be a minimal set of arcs of D such that $D' = D - A'$ contains no directed cycle, and let the length of a longest directed path in D' be k . Now assign colours $1, 2, \dots, k+1$ to the vertices of D' by assigning colour i to vertex v if the length of a longest directed path in D' with origin v is $i-1$. Denote by V_i the set of vertices with colour i . We shall show that $(V_1, V_2, \dots, V_{k+1})$ is a proper $(k+1)$ -vertex colouring of D .

First, observe that the origin and terminus of any directed path in D' have different colours. For let P be a directed (u, v) -path of positive length in D' and suppose $v \in V_i$. Then there is a directed path $Q = (v_1, v_2, \dots, v_i)$ in D' , where $v_1 = v$. Since D' contains no directed cycle, PQ is a directed path with origin u and length at least i . Thus $u \notin V_i$.

We can now show that the ends of any arc of D have different colours. Suppose $(u, v) \in A(D)$. If $(u, v) \in A(D')$ then (u, v) is a directed path in D' and so u and v have different colours. Otherwise, $(u, v) \in A'$. By the minimality of A' , $D' + (u, v)$ contains a directed cycle C . $C - (u, v)$ is a directed (v, u) -path in D' and hence in this case, too, u and v have different colours.

Thus $(V_1, V_2, \dots, V_{k+1})$ is a proper vertex colouring of D . It follows that $\chi \leq k+1$, and so D has a directed path of length $k \geq \chi - 1$ \square

Theorem 10.1 is best possible in that every graph G has an orientation in which the longest directed path is of length $\chi - 1$. Given a proper χ -vertex colouring $(V_1, V_2, \dots, V_\chi)$ of G , we orient G by converting edge uv to arc (u, v) if $u \in V_i$ and $v \in V_j$ with $i < j$. Clearly, no directed path in this orientation of G can contain more than χ vertices, since no two vertices of the path can have the same colour.

An orientation of a complete graph is called a *tournament*. The tournaments on four vertices are shown in figure 10.4. Each can be regarded as indicating the results of games in a round-robin tournament between four players; for example, the first tournament in figure 10.4 shows that one player has won all three games and that the other three have each won one.

A *directed Hamilton path* of D is a directed path that includes every

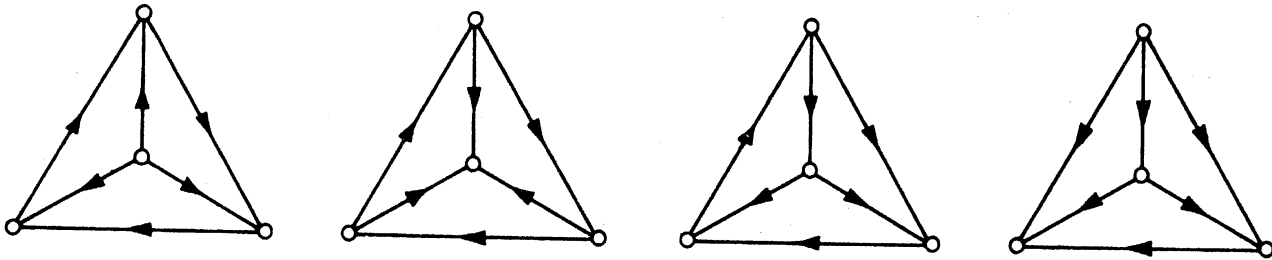

Figure 10.4. The tournaments on four vertices

vertex of D . An immediate corollary of theorem 10.1 is that every tournament has such a path. This was first proved by Rédei (1934).

Corollary 10.1 Every tournament has a directed Hamilton path.

Proof If D is a tournament, then $\chi = \nu$ \square

Another interesting fact about tournaments is that there is always a vertex from which every other vertex can be reached in at most two steps. We shall obtain this as a special case of a theorem of Chvátal and Lovász (1974). An *in-neighbour* of a vertex v in D is a vertex u such that $(u, v) \in A$; an *out-neighbour* of v is a vertex w such that $(v, w) \in A$. We denote the sets of in-neighbours and out-neighbours of v in D by $N_D^-(v)$ and $N_D^+(v)$, respectively.

Theorem 10.2 A loopless digraph D has an independent set S such that each vertex of D not in S is reachable from a vertex in S by a directed path of length at most two.

Proof By induction on ν . The theorem holds trivially for $\nu = 1$. Assume that it is true for all digraphs with fewer than ν vertices, and let v be an arbitrary vertex of D . By the induction hypothesis there exists in $D' = D - (\{v\} \cup N^+(v))$ an independent set S' such that each vertex of D' not in S' is reachable from a vertex in S' by a directed path of length at most two. If v is an out-neighbour of some vertex u of S' , then every vertex of $N^+(v)$ is reachable from u by a directed path of length two. Hence, in this case, $S = S'$ satisfies the required property. If, on the other hand, v is not an out-neighbour of any vertex of S' , then v is joined to no vertex of S' and the independent set $S = S' \cup \{v\}$ has the required property \square

Corollary 10.2 A tournament contains a vertex from which every other vertex is reachable by a directed path of length at most two.

Proof If D is a tournament, then $\alpha = 1$ \square

Exercises

- 10.2.1 Show that every tournament is either disconnected or can be transformed into a disconnected tournament by the reorientation of just one arc.
- 10.2.2* A digraph D is *unilateral* if, for any two vertices u and v , either v is reachable from u or u is reachable from v . Show that D is unilateral if and only if D has a spanning directed walk.
- 10.2.3 (a) Let $P = (v_1, v_2, \dots, v_k)$ be a maximal directed path in a tournament D . Suppose that P is not a directed Hamilton path and let v be any vertex not on P . Show that, for some i , both (v_i, v) and (v, v_{i+1}) are arcs of D .
 (b) Deduce Rédei's theorem.
- 10.2.4 Prove corollary 10.2 by considering a vertex of maximum outdegree.
- 10.2.5* (a) Let D be a digraph with $\chi > mn$, and let f be a real-valued function defined on V . Show that D has either a directed path (u_0, u_1, \dots, u_m) with $f(u_0) \leq f(u_1) \leq \dots \leq f(u_m)$ or a directed path (v_0, v_1, \dots, v_n) with $f(v_0) > f(v_1) > \dots > f(v_n)$.
 (V. Chvátal and J. Komlós)
 (b) Deduce that any sequence of $mn + 1$ distinct integers contains either an increasing subsequence of m terms or a decreasing subsequence of n terms.
 (P. Erdős and G. Szekeres)
- 10.2.6 (a) Using theorem 10.1 and corollary 8.1.2, show that G has an orientation in which each directed path is of length at most Δ .
 (b) Give a constructive proof of (a).

10.3 DIRECTED CYCLES

Corollary 10.1 tells us that every tournament contains a directed Hamilton path. Much stronger conclusions can be drawn, however, if the tournament is assumed to be disconnected. The following theorem is due to Moon (1966). If S and T are subsets of V , we denote by (S, T) the set of arcs of D that have their tails in S and their heads in T .

Theorem 10.3 Each vertex of a disconnected tournament D with $\nu \geq 3$ is contained in a directed k -cycle, $3 \leq k \leq \nu$.

Proof Let D be a disconnected tournament with $\nu \geq 3$, and let u be any vertex of D . Set $S = N^+(u)$ and $T = N^-(u)$. We first show that u is in a directed 3-cycle. Since D is disconnected, neither S nor T can be empty; and, for the same reason, (S, T) must be nonempty (see figure 10.5). There is thus some arc (v, w) in D with $v \in S$ and $w \in T$, and u is in the directed 3-cycle (u, v, w, u) .

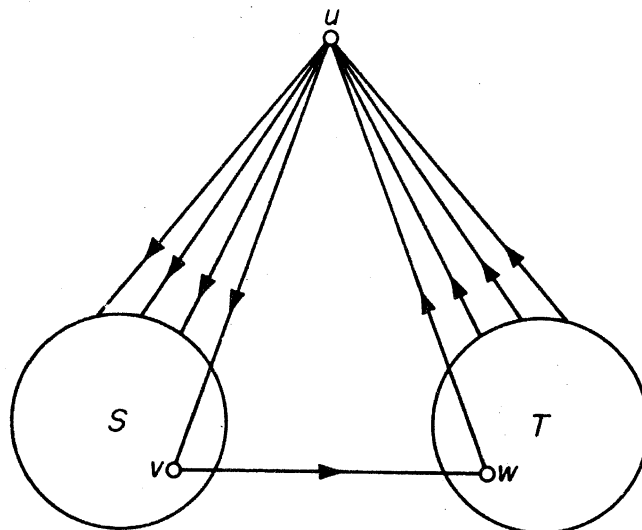

Figure 10.5

The theorem is now proved by induction on k . Suppose that u is in directed cycles of all lengths between 3 and n , where $n < \nu$. We shall show that u is in a directed $(n + 1)$ -cycle.

Let $C = (v_0, v_1, \dots, v_n)$ be a directed n -cycle in which $v_0 = v_n = u$. If there is a vertex v in $V(D) \setminus V(C)$ which is both the head of an arc with tail in C and the tail of an arc with head in C , then there are adjacent vertices v_i and v_{i+1} on C such that both (v_i, v) and (v, v_{i+1}) are arcs of D . In this case u is in the directed $(n + 1)$ -cycle $(v_0, v_1, \dots, v_i, v, v_{i+1}, \dots, v_n)$.

Otherwise, denote by S the set of vertices in $V(D) \setminus V(C)$ which are heads of arcs joined to C , and by T the set of vertices in $V(D) \setminus V(C)$ which are tails of arcs joined to C (see figure 10.6).

As before, since D is disconnected, S, T and (S, T) are all nonempty, and there is some arc (v, w) in D with $v \in S$ and $w \in T$. Hence u is in the directed $(n + 1)$ -cycle $(v_0, v, w, v_2, \dots, v_n)$ \square

A *directed Hamilton cycle* of D is a directed cycle that includes every vertex of D . It follows from theorem 10.3 (and was first proved by Camion, 1959) that every disconnected tournament contains such a cycle. The next

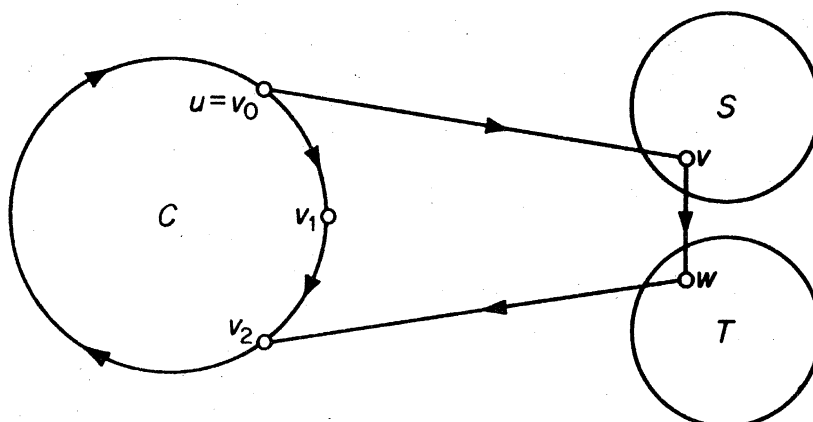

Figure 10.6

theorem extends Dirac's theorem (4.3) to digraphs. It is a special case of a theorem due to Ghouila-Houri (1960).

Theorem 10.4 If D is strict and $\min\{\delta^-, \delta^+\} \geq \nu/2 > 1$, then D contains a directed Hamilton cycle.

Proof Suppose that D satisfies the hypotheses of the theorem, but does not contain a directed Hamilton cycle. Denote the length of a longest directed cycle in D by l , and let $C = (v_1, v_2, \dots, v_l, v_1)$ be a directed cycle in D of length l . We note that $l > \nu/2$ (exercise 10.1.7). Let P be a longest directed path in $D - V(C)$ and suppose that P has origin u , terminus v and length m (see figure 10.7). Clearly

$$\nu \geq l + m + 1 \tag{10.1}$$

and, since $l > \nu/2$,

$$m < \nu/2 \tag{10.2}$$

Set

$$S = \{i \mid (v_{i-1}, u) \in A\} \quad \text{and} \quad T = \{i \mid (v, v_i) \in A\}$$

We first show that S and T are disjoint. Let $C_{j,k}$ denote the section of C with origin v_j and terminus v_k . If some integer i were in both S and T , D would contain the directed cycle $C_{i,i-1}(v_{i-1}, u)P(v, v_i)$ of length $l + m + 1$, contradicting the choice of C . Thus

$$S \cap T = \emptyset \tag{10.3}$$

Now, because P is a maximal directed path in $D - V(C)$, $N^-(u) \subseteq V(P) \cup V(C)$. But the number of in-neighbours of u in C is precisely $|S|$ and so $d_D^-(u) = d_P^-(u) + |S|$. Since $d_D^-(u) \geq \delta^- \geq \nu/2$ and $d_P^-(u) \leq m$,

$$|S| \geq \nu/2 - m \tag{10.4}$$

A similar argument yields

$$|T| \geq \nu/2 - m \tag{10.5}$$

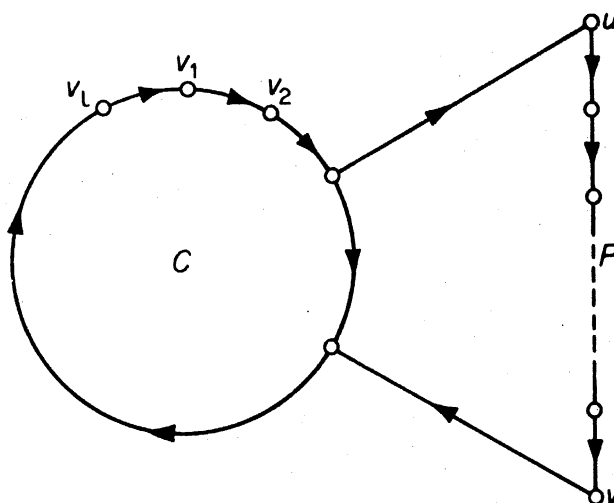

Figure 10.7

Note that, by (10.2), both S and T are nonempty. Adding (10.4) and (10.5) and using (10.1), we obtain

$$|S| + |T| \geq l - m + 1$$

and therefore, by (10.3),

$$|S \cup T| \geq l - m + 1 \quad (10.6)$$

Since S and T are disjoint and nonempty, there are positive integers i and k such that $i \in S$, $i + k \in T$ and

$$i + j \notin S \cup T \quad \text{for } 1 \leq j < k \quad (10.7)$$

where addition is taken modulo l .

From (10.6) and (10.7) we see that $k \leq m$. Thus the directed cycle $C_{i+k, i-1}(v_{i-1}, u)P(v, v_{i+k})$, which has length $l + m + 1 - k$, is longer than C . This contradiction establishes the theorem \square

Exercises

- 10.3.1 Show how theorem 4.3 can be deduced from theorem 10.4.
- 10.3.2** A *directed Euler tour* of D is a directed tour that traverses each arc of D exactly once. Show that D contains a directed Euler tour if and only if D is connected and $d^+(v) = d^-(v)$ for all $v \in V$.
- 10.3.3** Let D be a digraph such that
- $d^+(x) - d^-(x) = l = d^-(y) - d^+(y)$;
 - $d^+(v) = d^-(v)$ for $v \in V \setminus \{x, y\}$.
- Show, using exercise 10.3.2, that there exist l arc-disjoint directed (x, y) -paths in D .
- 10.3.4* Show that a disconnected digraph which contains an odd cycle, also contains a directed odd cycle.
- 10.3.5 A nontrivial digraph D is *k-arc-connected* if, for every nonempty proper subset S of V , $|(S, \bar{S})| \geq k$. Show that a nontrivial digraph is disconnected if and only if it is 1-arc-connected.
- 10.3.6** The *associated digraph* $D(G)$ of a graph G is the digraph obtained when each edge e of G is replaced by two oppositely oriented arcs with the same ends as e . Show that
- there is a one-one correspondence between paths in G and directed paths in $D(G)$;
 - $D(G)$ is *k-arc-connected* if and only if G is *k-edge-connected*.

APPLICATIONS

10.4 A JOB SEQUENCING PROBLEM

A number of jobs J_1, J_2, \dots, J_n , have to be processed on one machine; for example, each J_i might be an order of bottles or jars in a glass factory. After

each job, the machine must be adjusted to fit the requirements of the next job. If the time of adaptation from job J_i to job J_j is t_{ij} , find a sequencing of the jobs that minimises the total machine adjustment time.

This problem is clearly related to the travelling salesman problem, and no efficient method for its solution is known. It is therefore desirable to have a method for obtaining a reasonably good (but not necessarily optimal) solution. Our method makes use of Rédei's theorem (corollary 10.1).

Step 1 Construct a digraph D with vertices v_1, v_2, \dots, v_n , such that $(v_i, v_j) \in A$ if and only if $t_{ij} \leq t_{ji}$. By definition, D contains a spanning tournament.

Step 2 Find a directed Hamilton path $(v_{i_1}, v_{i_2}, \dots, v_{i_n})$ of D (exercise 10.4.1), and sequence the jobs accordingly.

Since step 1 discards the larger half of the adjustment matrix $[t_{ij}]$, it is a reasonable supposition that this method, in general, produces a fairly good job sequence. Note, however, that when the adjustment matrix is symmetric, the method is of no help whatsoever.

As an example, suppose that there are six jobs J_1, J_2, J_3, J_4, J_5 and J_6 and that the adjustment matrix is

	J_1	J_2	J_3	J_4	J_5	J_6
J_1	0	5	3	4	2	1
J_2	1	0	1	2	3	2
J_3	2	5	0	1	2	3
J_4	1	4	4	0	1	2
J_5	1	3	4	5	0	5
J_6	4	4	2	3	1	0

The sequence $J_1 \rightarrow J_2 \rightarrow J_3 \rightarrow J_4 \rightarrow J_5 \rightarrow J_6$ requires 13 units in adjustment time. To find a better sequence, construct the digraph D as in step 1 (figure 10.8).

$(v_1, v_6, v_3, v_4, v_5, v_2)$ is a directed Hamilton path of D , and yields the sequence

$$J_1 \rightarrow J_6 \rightarrow J_3 \rightarrow J_4 \rightarrow J_5 \rightarrow J_2$$

which requires only eight units of adjustment time. Note that the reverse sequence

$$J_2 \rightarrow J_5 \rightarrow J_4 \rightarrow J_3 \rightarrow J_6 \rightarrow J_1$$

is far worse, requiring 19 units of adjustment time.

Exercises

10.4.1 With the aid of exercise 10.2.3, describe a good algorithm for finding a directed Hamilton path in a tournament.

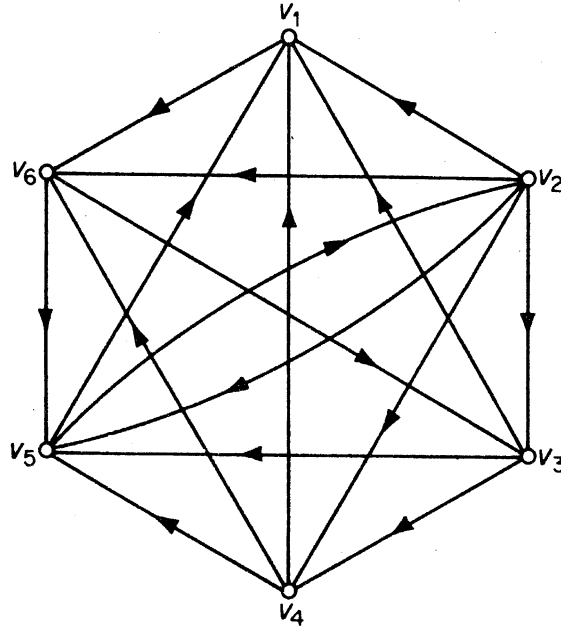

Figure 10.8

10.4.2 Show, by means of an example, that a sequencing of jobs obtained by the above method may be far from optimal.

10.5 DESIGNING AN EFFICIENT COMPUTER DRUM

The position of a rotating drum is to be recognised by means of binary signals produced at a number of electrical contacts at the surface of the drum. The surface is divided into 2^n sections, each consisting of either insulating or conducting material. An insulated section gives signal 0 (no current), whereas a conducting section gives signal 1 (current). For example, the position of the drum in figure 10.9 gives a reading 0010 at the four

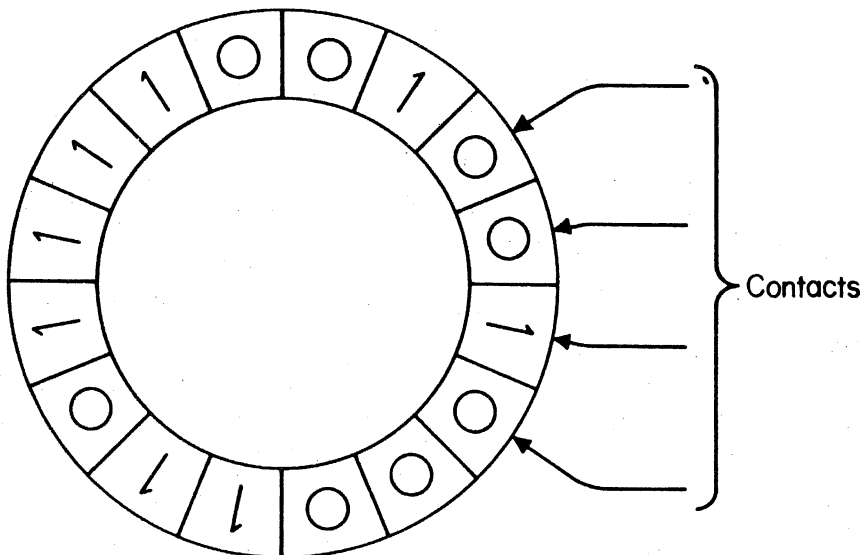

Figure 10.9. A computer drum

contacts. If the drum were rotated clockwise one section, the reading would be 1001. Thus these two positions can be distinguished, since they give different readings. However, a further rotation of two sections would result in another position with reading 0010, and therefore this latter position is indistinguishable from the initial one.

We wish to design the drum surface in such a way that the 2^n different positions of the drum can be distinguished by k contacts placed consecutively around part of the drum, and we would like this number k to be as small as possible. How can this be accomplished?

First note that k contacts yield a k -digit binary number, and there are 2^k such numbers. Therefore, if all 2^n positions are to give different readings, we must have $2^k \geq 2^n$, that is, $k \geq n$. We shall show that the surface of the drum can be designed in such a way that n contacts suffice to distinguish all 2^n positions.

We define a digraph D_n as follows: the vertices of D_n are the $(n-1)$ -digit binary numbers $p_1p_2 \dots p_{n-1}$ with $p_i = 0$ or 1 . There is an arc with tail $p_1p_2 \dots p_{n-1}$ and head $q_1q_2 \dots q_{n-1}$ if and only if $p_{i+1} = q_i$ for $1 \leq i \leq n-2$; in other words, all arcs are of the form $(p_1p_2 \dots p_{n-1}, p_2p_3 \dots p_n)$. In addition, each arc $(p_1p_2 \dots p_{n-1}, p_2p_3 \dots p_n)$ of D_n is assigned the label $p_1p_2 \dots p_n$. D_4 is shown in figure 10.10.

Clearly, D_n is connected and each vertex of D_n has indegree two and outdegree two. Therefore (exercise 10.3.2) D_n has a directed Euler tour. This directed Euler tour, regarded as a sequence of arcs of D_n , yields a binary sequence of length 2^n suitable for the design of the drum surface.

For example, the digraph D_4 of figure 10.10 has a directed Euler tour $(a_1, a_2, \dots, a_{16})$, giving the 16-digit binary sequence 0000111100101101. (Just read off the first digits of the labels of the a_i .) A drum constructed from this sequence is shown in figure 10.11.

This application of directed Euler tours is due to Good (1946).

Exercises

- 10.5.1. Find a circular sequence of seven 0's and seven 1's such that all 4-digit binary numbers except 0000 and 1111 appear as blocks of the sequence.
- 10.5.2 Let S be an alphabet of n letters. Show that there is a circular sequence containing n^3 copies of each letter such that every four-letter 'word' formed from letters of S appears as a block of the sequence.

10.6 MAKING A ROAD SYSTEM ONE-WAY

Given a road system, how can it be converted to one-way operation so that traffic may flow as smoothly as possible?

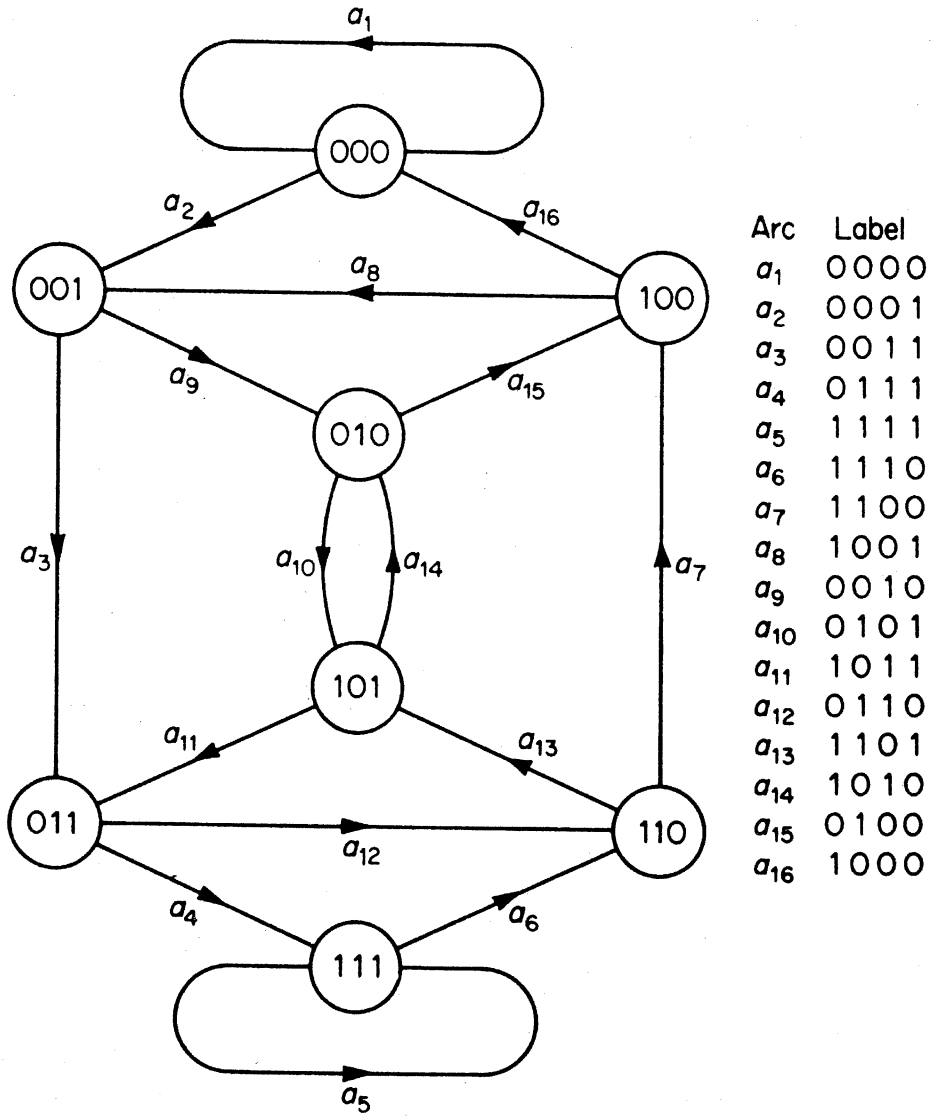

Figure 10.10

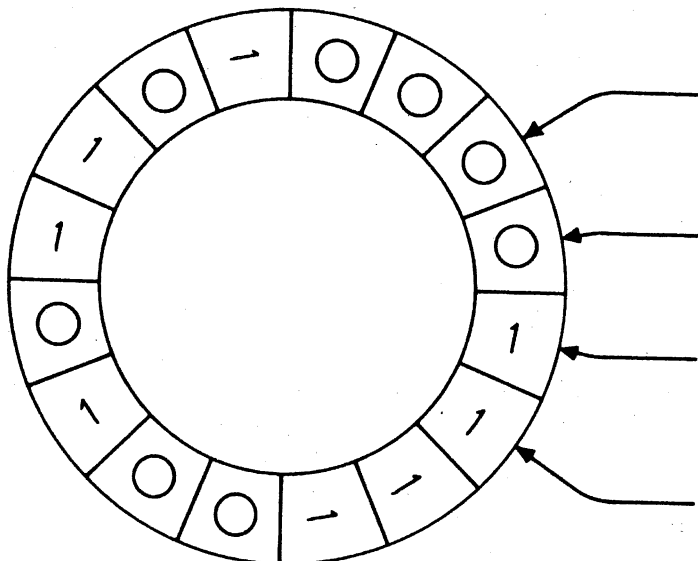

Figure 10.11

This is clearly a problem on orientations of graphs. Consider, for example, the two graphs, representing road networks, in figures 10.12a and 10.12b.

No matter how G_1 may be oriented, the resulting orientation cannot be disconnected—traffic will not be able to flow freely through the system. The trouble is that G_1 has a cut edge. On the other hand G_2 has the ‘balanced’ orientation D_2 (figure 10.12c), in which each vertex is reachable from each other vertex in at most two steps; in particular D_2 is disconnected.

Certainly, a necessary condition for G to have a disconnected orientation is that G be 2-edge-connected. Robbins (1939) showed that this condition is also sufficient.

Theorem 10.5 If G is 2-edge-connected, then G has a disconnected orientation.

Proof Let G be 2-edge-connected. Then G contains a cycle G_1 . We define inductively a sequence G_1, G_2, \dots of connected subgraphs of G as follows: if G_i ($i = 1, 2, \dots$) is not a spanning subgraph of G , let v_i be a vertex of G not in G_i . Then (exercise 3.2.1) there exist edge-disjoint paths P_i and Q_i from v_i to G_i . Define

$$G_{i+1} = G_i \cup P_i \cup Q_i$$

Since $\nu(G_{i+1}) > \nu(G_i)$, this sequence must terminate in a spanning subgraph G_n of G .

We now orient G_n by orienting G_1 as a directed cycle, each path P_i as a directed path with origin v_i , and each path Q_i as a directed path with terminus v_i . Clearly every G_i , and hence in particular G_n , is thereby given a disconnected orientation. Since G_n is a spanning subgraph of G it follows that G , too, has a disconnected orientation \square

Nash-Williams (1960) has generalised Robbins’ theorem by showing that every $2k$ -edge-connected graph G has a k -arc-connected orientation. Although the proof of this theorem is difficult, the special case when G has an Euler trail admits of a simple proof.

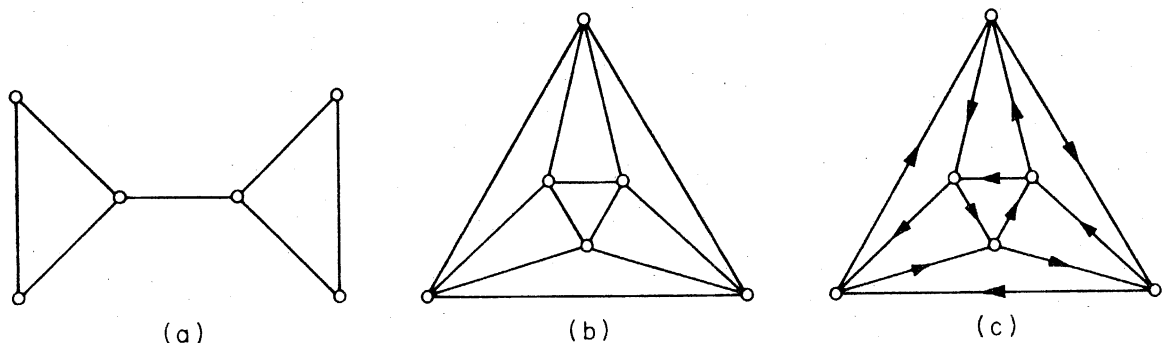

Figure 10.12. (a) G_1 ; (b) G_2 ; (c) D_2

Theorem 10.6 Let G be a $2k$ -edge-connected graph with an Euler trail. Then G has a k -arc-connected orientation.

Proof Let $v_0 e_1 v_1 \dots e_\varepsilon v_\varepsilon$ be an Euler trail of G . Orient G by converting the edge e_i with ends v_{i-1} and v_i to an arc a_i with tail v_{i-1} and head v_i , for $1 \leq i \leq \varepsilon$. Now let $[S, \bar{S}]$ be an m -edge cut of G . The number of times the directed trail $(v_0, a_1, v_1, \dots, a_\varepsilon, v_\varepsilon)$ crosses from S to \bar{S} differs from the number of times it crosses from \bar{S} to S by at most one. Since it includes all arcs of D , both (S, \bar{S}) and (\bar{S}, S) must contain at least $\lceil m/2 \rceil$ arcs. The result follows \square

Exercises

- 10.6.1 Show, by considering the Petersen graph, that the following statement is false: every graph G has an orientation in which, for every $S \subseteq V$, the cardinalities of (S, \bar{S}) and (\bar{S}, S) differ by at most one.
- 10.6.2 (a) Show that Nash-Williams' theorem is equivalent to the following statement: if every bond of G has at least $2k$ edges, then there is an orientation of G in which every bond has at least k arcs in each direction.
- (b) Show, by considering the Grötzsch graph (figure 8.2), that the following analogue of Nash-Williams' theorem is false: if every cycle of G has at least $2k$ edges, then there is an orientation of G in which every cycle has at least k arcs in each direction.

10.7 RANKING THE PARTICIPANTS IN A TOURNAMENT

A number of players each play one another in a tennis tournament. Given the outcomes of the games, how should the participants be ranked?

Consider, for example, the tournament of figure 10.13: This represents the result of a tournament between six players; we see that player 1 beat players 2, 4, 5 and 6 and lost to player 3, and so on.

One possible approach to ranking the participants would be to find a directed Hamilton path in the tournament (such a path exists by virtue of corollary 10.1), and then rank according to the position on the path. For instance, the directed Hamilton path $(3, 1, 2, 4, 5, 6)$ would declare player 3 the winner, player 1 runner-up, and so on. This method of ranking, however, does not bear further examination, since a tournament generally has many directed Hamilton paths; our example has $(1, 2, 4, 5, 6, 3)$, $(1, 4, 6, 3, 2, 5)$ and several others.

Another approach would be to compute the scores (numbers of games won by each player) and compare them. If we do this we obtain the score vector

$$s_1 = (4, 3, 3, 2, 2, 1)$$

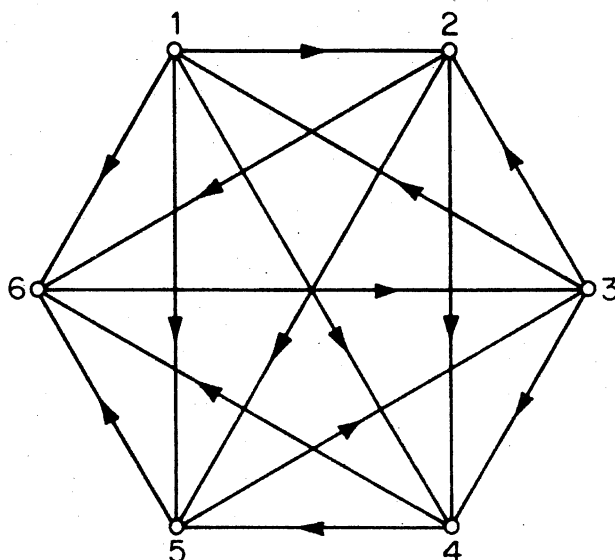

Figure 10.13

The drawback here is that this score vector does not distinguish between players 2 and 3 even though player 3 beat players with higher scores than did player 2. We are thus led to the second-level score vector

$$\mathbf{s}_2 = (8, 5, 9, 3, 4, 3)$$

in which each player's second-level score is the sum of the scores of the players he beat. Player 3 now ranks first. Continuing this procedure we obtain further vectors

$$\mathbf{s}_3 = (15, 10, 16, 7, 12, 9)$$

$$\mathbf{s}_4 = (38, 28, 32, 21, 25, 16)$$

$$\mathbf{s}_5 = (90, 62, 87, 41, 48, 32)$$

$$\mathbf{s}_6 = (183, 121, 193, 80, 119, 87)$$

The ranking of the players is seen to fluctuate a little, player 3 vying with player 1 for first place. We shall show that this procedure always converges to a fixed ranking when the tournament in question is disconnected and has at least four vertices. This will then lead to a method of ranking the players in any tournament.

In a disconnected digraph D , the length of a shortest directed (u, v) -path is denoted by $\vec{d}_D(u, v)$ and is called the *distance from u to v* ; the *directed diameter* of D is the maximum distance from any one vertex of D to any other.

Theorem 10.7 Let D be a disconnected tournament with $v \geq 5$, and let \mathbf{A} be the adjacency matrix of D . Then $\mathbf{A}^{d+3} > \mathbf{0}$ (every entry positive), where d is the directed diameter of D .

Proof The (i, j) th entry of \mathbf{A}^k is precisely the number of directed (v_i, v_j) -walks of length k in D (exercise 10.1.8). We must therefore show that, for any two vertices v_i and v_j (possibly identical), there is a directed (v_i, v_j) -walk of length $d + 3$.

Let $d_{ij} = \vec{d}(v_i, v_j)$. Then $0 \leq d_{ij} \leq d \leq \nu - 1$ and therefore

$$3 \leq d - d_{ij} + 3 \leq \nu + 2$$

If $d - d_{ij} + 3 \leq \nu$ then, by theorem 10.3, there is a directed $(d - d_{ij} + 3)$ -cycle C containing v_j . A directed (v_i, v_j) -path P of length d_{ij} followed by the directed cycle C together form a directed (v_i, v_j) -walk of length $d + 3$, as desired.

There are two special cases. If $d - d_{ij} + 3 = \nu + 1$, then P followed by a directed $(\nu - 2)$ -cycle through v_j followed by a directed 3-cycle through v_j constitute a directed (v_i, v_j) -walk of length $d + 3$ (the $(\nu - 2)$ -cycle exists since $\nu \geq 5$); and if $d - d_{ij} + 3 = \nu + 2$, then P followed by a directed $(\nu - 1)$ -cycle through v_j followed by a directed 3-cycle through v_j constitute such a walk \square

A real matrix \mathbf{R} is called *primitive* if $\mathbf{R}^k > \mathbf{0}$ for some k .

Corollary 10.7 The adjacency matrix \mathbf{A} of a tournament D is primitive if and only if D is diconnected and $\nu \geq 4$.

Proof If D is not diconnected, then there are vertices v_i and v_j in D such that v_j is not reachable from v_i . Thus there is no directed (v_i, v_j) -walk in D . It follows that the (i, j) th entry of \mathbf{A}^k is zero for all k , and hence \mathbf{A} is not primitive.

Conversely, suppose that D is diconnected. If $\nu \geq 5$ then, by theorem 10.7, $\mathbf{A}^{d+3} > \mathbf{0}$ and so \mathbf{A} is primitive. There is just one diconnected tournament on three vertices (figure 10.14a), and just one diconnected tournament on four vertices (figure 10.14b). It is readily checked that the adjacency

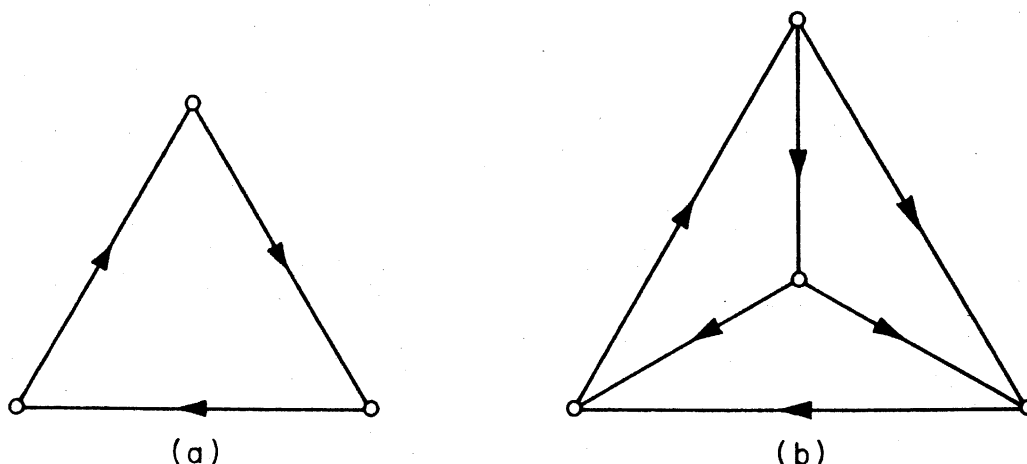

Figure 10.14

matrix of the 3-vertex tournament is not primitive, and it can be shown that the ninth power of the adjacency matrix of the 4-vertex tournament has all entries positive \square

Returning now to the score vectors, we see that the i th-level score vector in a tournament D is given by

$$s_i = \mathbf{A}^i \mathbf{J}$$

where \mathbf{A} is the adjacency matrix of D , and \mathbf{J} is a column vector of 1's. If the matrix \mathbf{A} is primitive then, by the Perron–Frobenius theorem (see Gantmacher, 1960), the eigenvalue of \mathbf{A} with largest absolute value is a real positive number r and, furthermore,

$$\lim_{i \rightarrow \infty} \left(\frac{\mathbf{A}}{r} \right)^i \mathbf{J} = \mathbf{s}$$

where \mathbf{s} is a positive eigenvector of \mathbf{A} corresponding to r . Therefore, by corollary 10.7, if D is a disconnected tournament on at least four vertices, the normalised vector $\bar{\mathbf{s}}$ (with entries summing to one) can be taken as the vector of relative strengths of the players in D . In the example of figure 10.13, we find that (approximately)

$$r = 2.232 \quad \text{and} \quad \bar{\mathbf{s}} = (.238, .164, .231, .113, .150, .104)$$

Thus the ranking of the players given by this method is 1, 3, 2, 5, 4, 6.

If the tournament is not disconnected, then (exercises 10.1.9 and 10.1.3b) its dicomponents can be linearly ordered so that the ordering preserves dominance. The participants in a round-robin tournament can now be ranked according to the following procedure.

Step 1 In each dicomponent on four or more vertices, rank the players using the eigenvector $\bar{\mathbf{s}}$; in a dicomponent on three vertices rank all three players equal.

Step 2 Rank the dicomponents in their dominance-preserving linear order D_1, D_2, \dots, D_m ; that is, if $i < j$ then every arc with one end in D_i and one end in D_j has its head in D_j .

This method of ranking is due to Wei (1952) and Kendall (1955). For other ranking procedures, see Moon and Pullman (1970).

Exercises

- 10.7.1 Apply the method of ranking described in section 10.7 to
- the four tournaments shown in figure 10.4;
 - the tournament with adjacency matrix

	A	B	C	D	E	F	G	H	I	J
A	0	1	1	1	1	1	0	0	1	1
B	0	0	1	0	0	1	0	0	0	0
C	0	0	0	0	0	0	0	0	0	0
D	0	1	1	0	1	1	0	0	1	0
E	0	1	1	0	0	0	0	0	0	0
F	0	0	1	0	1	0	0	0	0	0
G	1	1	1	1	1	1	0	0	1	0
H	1	1	1	1	1	1	1	0	1	1
I	0	1	1	0	1	0	0	0	0	0
J	0	1	1	1	1	1	1	0	1	0

10.7.2 An alternative method of ranking is to consider 'loss vectors' instead of score vectors.

- Show that this amounts to ranking the converse tournament and then reversing the ranking so found.
- By considering the disconnected tournament on four vertices, show that the two methods of ranking do not necessarily yield the same result.

REFERENCES

- Camion, P. (1959). Chemins et circuits hamiltoniens des graphes complets. *C.R. Acad. Sci. Paris*, **249**, 2151-52
- Chvátal, V. and Lovász, L. (1974). Every directed graph has a semi-kernel, in *Hypergraph Seminar* (eds. C. Berge and D. K. Ray-Chaudhuri), Springer-Verlag, New York, p. 175
- Gallai, T. (1968). On directed paths and circuits, in *Theory of Graphs* (eds. P. Erdős and G. Katona), Academic Press, New York, pp. 115-18
- Gantmacher F. R. (1960). *Theory of Matrices*, Chelsea, New York
- Ghouila-Houri, A. (1960). Une condition suffisante d'existence d'un circuit hamiltonien. *C. R. Acad. Sci. Paris*, **251**, 495-97
- Good, I. J. (1946). Normal recurring decimals. *J. London Math. Soc.* **21**, 167-72
- Kendall, M. G. (1955). Further contributions to the theory of paired comparisons. *Biometrics*, **11**, 43-62
- Moon, J. W. (1966). On subtournaments of a tournament. *Canad. Math. Bull.*, **9**, 297-301
- Moon, J. W. and Pullman, N. J. (1970). On generalised tournament matrices. *SIAM Rev.*, **12**, 384-399
- Nash-Williams, C. St. J. A. (1960). On orientations, connectivity and odd-vertex pairings in finite graphs. *Canad. J. Math.*, **12**, 555-67

- Rédei, L. (1934). Ein kombinatorischer Satz. *Acta Litt. Sci. Szeged*, **7**, 39–43
- Robbins, H. E. (1939). A theorem on graphs, with an application to a problem of traffic control. *Amer. Math. Monthly*, **46**, 281–83
- Roy, B. (1967). Nombre chromatique et plus longs chemins d'un graphe, *Rev. Francaise Automat. Informat. Recherche Operationelle Sér. Rouge*, **1**, 127–32
- Wei, T. H. (1952). *The Algebraic Foundations of Ranking Theory*. Ph.D. Thesis, Cambridge University