

**Recommended schedule**

---

Day 1

Topics: *Mixed-frequency signals and harmonic analysis*

Questions: *1 through 15*

Lab Exercise: *Digital oscilloscope set-up (question 61)*

---

Day 2

Topics: *Intro to calculus: differentiation and integration (optional)*

Questions: *16 through 30*

Lab Exercise: *Passive integrator circuit (question 62)*

---

Day 3

Topics: *Passive integrator and differentiator circuits*

Questions: *31 through 45*

Lab Exercise: *Passive differentiator circuit (question 63)*

---

Day 4

Topics: *Using oscilloscope trigger controls*

Questions: *46 through 60*

Lab Exercise: *work on project*

---

Day 5

Exam 3: *includes oscilloscope set-up performance assessment*

**Project due**

Question 64: *Sample project grading criteria*

---

Practice and challenge problems

Questions: *65 through the end of the worksheet*

Skill standards addressed by this course section

---

EIA Raising the Standard: Electronics Technician Skills for Today and Tomorrow, June 1994

**C Technical Skills – AC circuits**

- C.02** Demonstrate an understanding of the properties of an AC signal.
- C.03** Demonstrate an understanding of the principles of operation and characteristics of sinusoidal and non-sinusoidal wave forms.
- C.18** Understand principles and operations of AC differentiator and integrator circuits (determine RC and RL time constants).
- C.19** Fabricate and demonstrate AC differentiator and integrator circuits.
- C.20** Troubleshoot and repair AC differentiator and integrator circuits.

**B Basic and Practical Skills – Communicating on the Job**

- B.01** Use effective written and other communication skills. *Met by group discussion and completion of labwork.*
- B.03** Employ appropriate skills for gathering and retaining information. *Met by research and preparation prior to group discussion.*
- B.04** Interpret written, graphic, and oral instructions. *Met by completion of labwork.*
- B.06** Use language appropriate to the situation. *Met by group discussion and in explaining completed labwork.*
- B.07** Participate in meetings in a positive and constructive manner. *Met by group discussion.*
- B.08** Use job-related terminology. *Met by group discussion and in explaining completed labwork.*
- B.10** Document work projects, procedures, tests, and equipment failures. *Met by project construction and/or troubleshooting assessments.*

**C Basic and Practical Skills – Solving Problems and Critical Thinking**

- C.01** Identify the problem. *Met by research and preparation prior to group discussion.*
- C.03** Identify available solutions and their impact including evaluating credibility of information, and locating information. *Met by research and preparation prior to group discussion.*
- C.07** Organize personal workloads. *Met by daily labwork, preparatory research, and project management.*
- C.08** Participate in brainstorming sessions to generate new ideas and solve problems. *Met by group discussion.*

**D Basic and Practical Skills – Reading**

- D.01** Read and apply various sources of technical information (e.g. manufacturer literature, codes, and regulations). *Met by research and preparation prior to group discussion.*

**E Basic and Practical Skills – Proficiency in Mathematics**

- E.01** Determine if a solution is reasonable.
- E.02** Demonstrate ability to use a simple electronic calculator.
- E.05** Solve problems and [sic] make applications involving integers, fractions, decimals, percentages, and ratios using order of operations.
- E.06** Translate written and/or verbal statements into mathematical expressions.
- E.09** Read scale on measurement device(s) and make interpolations where appropriate. *Met by oscilloscope usage.*
- E.12** Interpret and use tables, charts, maps, and/or graphs.
- E.13** Identify patterns, note trends, and/or draw conclusions from tables, charts, maps, and/or graphs.
- E.15** Simplify and solve algebraic expressions and formulas.
- E.16** Select and use formulas appropriately.
- E.17** Understand and use scientific notation.
- E.26** Apply Pythagorean theorem.
- E.27** Identify basic functions of sine, cosine, and tangent.
- E.28** Compute and solve problems using basic trigonometric functions.

---

**Common areas of confusion for students**

---

**Difficult concept:** *Fourier analysis.*

No doubt about it, Fourier analysis is a strange concept to understand. Strange, but incredibly useful! While it is relatively easy to grasp the principle that we may create a square-shaped wave (or any other symmetrical waveshape) by mixing together the right combinations of sine waves at different frequencies and amplitudes, it is far from obvious that *any* periodic waveform may be decomposed into a series of sinusoidal waves the same way. The practical upshot of this is that it is possible to consider very complex waveshapes as being nothing more than a bunch of sine waves added together. Since sine waves are easy to analyze in the context of electric circuits, this means we have a way of simplifying what would otherwise be a dauntingly complex problem: analyzing how circuits respond to non-sinusoidal waveforms.

The actual "nuts and bolts" of Fourier analysis is highly mathematical and well beyond the scope of this course. Right now all I want you to grasp is the concept and significance of equivalence between arbitrary waveshapes and series of sine waves.

A great way to experience this equivalence is to play with a digital oscilloscope with a built-in spectrum analyzer. By introducing different wave-shape signals to the input and switching back and forth between the time-domain (scope) and frequency-domain (spectrum) displays, you may begin to see patterns that will enlighten your understanding.

**Difficult concept:** *Rates of change.*

When studying integrator and differentiator circuits, one must think in terms of how fast a variable is changing. This is the first hurdle in calculus: to comprehend what a rate of change is, and it is not obvious. One thing I really like about teaching electronics is that capacitor and inductor circuits naturally exhibit the calculus principles of integration and differentiation (with respect to time), and so provide an excellent context in which the electronics student may explore basic principles of calculus. Integrator and differentiator circuits exploit these properties, so that the output voltage is approximately either the time-integral or time-derivative (respectively) of the input voltage signal.

It is helpful, though, to relate these principles to more ordinary contexts, which is why I often describe rates of change in terms of *velocity* and *acceleration*. Velocity is nothing more than a rate of change of position: how quickly one's position is changing over time. Therefore, if the variable  $x$  describes position, then the derivative  $\frac{dx}{dt}$  (rate of change of  $x$  over time  $t$ ) must describe velocity. Likewise, acceleration is nothing more than the rate of change of velocity: how quickly velocity changes over time. If the variable  $v$  describes velocity, then the derivative  $\frac{dv}{dt}$  must describe acceleration. Or, since we know that velocity is itself the derivative of position, we could describe acceleration as the *second derivative* of position:  $\frac{d^2x}{dt^2}$ .

**Difficult concept:** *Derivative versus integral.*

The two foundational concepts of calculus are inversely related: *differentiation* and *integration* are flip-sides of the same coin. That is to say, one "un-does" the other.

One of the better ways to illustrate the inverse nature of these two operations is to consider them in the context of motion analysis, relating *position* ( $x$ ), *velocity* ( $v$ ), and *acceleration* ( $a$ ). Differentiating with respect to time, the derivative of position is velocity ( $v = \frac{dx}{dt}$ ), and the derivative of velocity is acceleration ( $a = \frac{dv}{dt}$ ). Integrating with respect to time, the integral of acceleration is velocity ( $v = \int a dt$ ) and the integral of velocity is position ( $x = \int v dt$ ).

Fortunately, electronics provides a ready context in which to understand differentiation and integration. It is very easy to build *differentiator* and *integrator* circuits, which take a voltage signal input and differentiate or integrate (respectively) that signal with respect to time. This means if we have a voltage signal from a velocity sensor measuring the velocity of an object (such as a robotic arm, for example), we may send that signal through a differentiator circuit to obtain a voltage signal representing the robotic arm's acceleration, or we may send the velocity signal through an integrator circuit to obtain a voltage signal representing the robotic arm's position.

## Questions

---

### Question 1

What is a musical *chord*? If viewed on an oscilloscope, what would the signal for a chord look like?

[file 00647](#)

---

### Question 2

What is a *harmonic* frequency? If a particular electronic system (such as an AC power system) has a fundamental frequency of 60 Hz, calculate the frequencies of the following harmonics:

- 1st harmonic =
- 2nd harmonic =
- 3rd harmonic =
- 4th harmonic =
- 5th harmonic =
- 6th harmonic =

[file 01890](#)

---

### Question 3

An *octave* is a type of harmonic frequency. Suppose an electronic circuit operates at a fundamental frequency of 1 kHz. Calculate the frequencies of the following octaves:

- 1 octave greater than the fundamental =
- 2 octaves greater than the fundamental =
- 3 octaves greater than the fundamental =
- 4 octaves greater than the fundamental =
- 5 octaves greater than the fundamental =
- 6 octaves greater than the fundamental =

[file 01891](#)

---

Question 4

An interesting thing happens if we take the odd-numbered harmonics of a given frequency and add them together at certain diminishing ratios of the fundamental's amplitude. For instance, consider the following harmonic series:

$$(1 \text{ volt at } 100 \text{ Hz}) + (1/3 \text{ volt at } 300 \text{ Hz}) + (1/5 \text{ volt at } 500 \text{ Hz}) + (1/7 \text{ volt at } 700 \text{ Hz}) + \dots$$

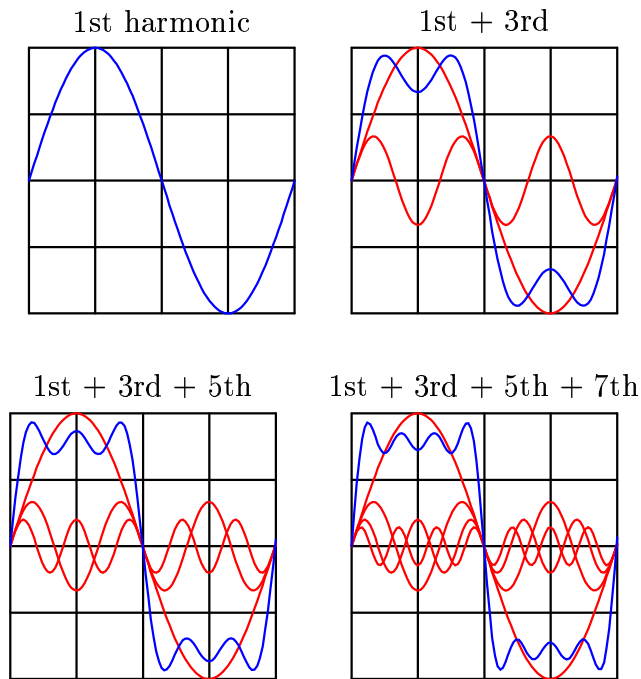

Here is what the composite wave would look like if we added all odd-numbered harmonics up to the 13th together, following the same pattern of diminishing amplitudes:

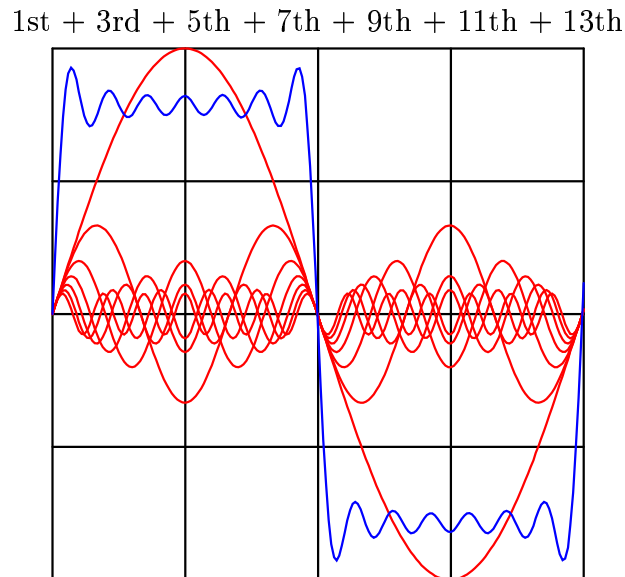

If we take this progression even further, you can see that the sum of these harmonics begins to appear more like a square wave:

All odd-numbered harmonics up to the 35th

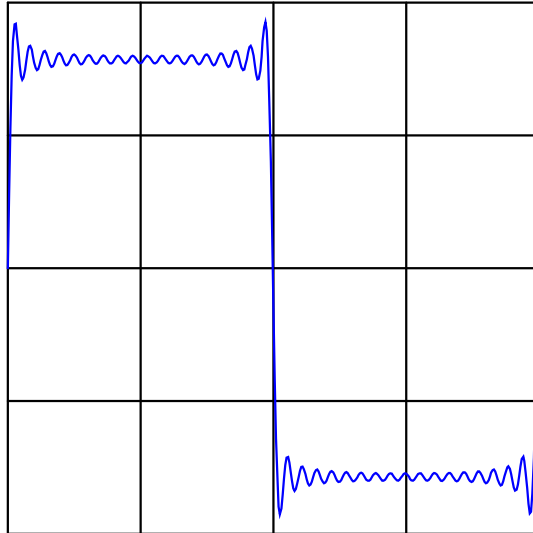

This mathematical equivalence between a square wave and the weighted sum of all odd-numbered harmonics is very useful in analyzing AC circuits where square-wave signals are present. From the perspective of AC circuit analysis based on sinusoidal waveforms, how would you describe the way an AC circuit "views" a square wave?

file 01597

---

Question 5

Calculate the power dissipated by a  $25\ \Omega$  resistor, when powered by a square-wave with a symmetrical amplitude of 100 volts and a frequency of 2 kHz:

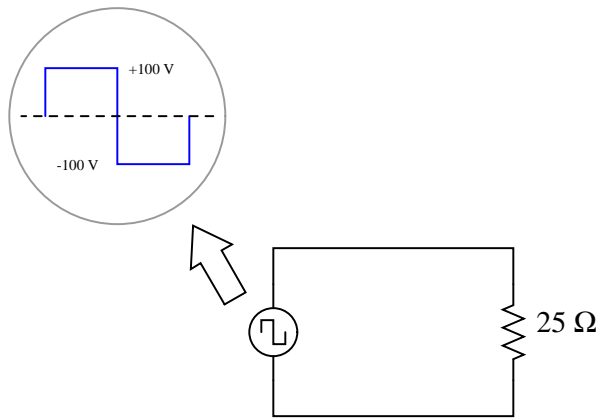

file 00651

---

Question 6

Calculate the power dissipated by a  $25\ \Omega$  resistor, when powered by a square-wave with a symmetrical amplitude of 100 volts and a frequency of 2 kHz, through a  $0.22\ \mu\text{F}$  capacitor:

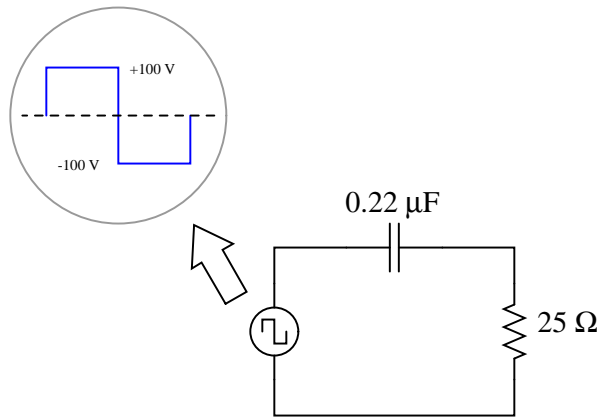

No, I'm not asking you to calculate an infinite number of terms in the Fourier series – that would be cruel and unusual. Just calculate the power dissipated in the resistor by the 1st, 3rd, 5th, and 7th harmonics only.

[file 00652](#)

---

Question 7

In the early 1800's, French mathematician Jean Fourier discovered an important principle of waves that allows us to more easily analyze non-sinusoidal signals in AC circuits. Describe the principle of the *Fourier series*, in your own words.

[file 00650](#)

---

Question 8

Identify the type of electronic instrument that displays the relative amplitudes of a range of signal frequencies on a graph, with amplitude on the vertical axis and frequency on the horizontal.

[file 00649](#)

---

Question 9

What causes harmonics to form in AC electric power systems?

[file 00653](#)

---

Question 10

Under certain conditions, harmonics may be produced in AC power systems by inductors and transformers. How is this possible, as these devices are normally considered to be linear?

[file 00655](#)

Question 11

Note the effect of adding the second harmonic of a waveform to the fundamental, and compare that effect with adding the *third* harmonic of a waveform to the fundamental:

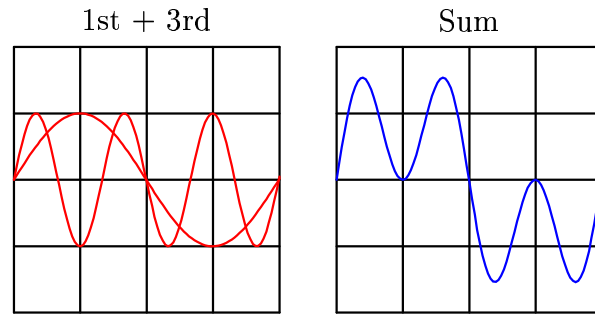
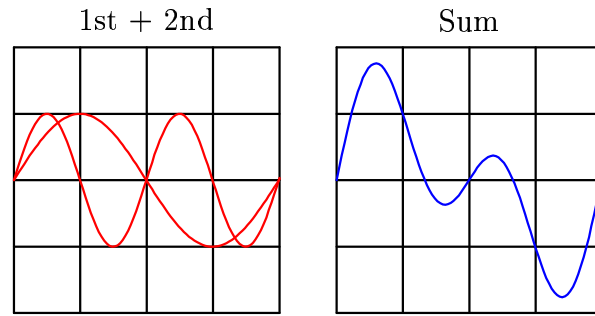

Now compare the sums of a fundamental with its fourth harmonic, versus with its fifth harmonic:

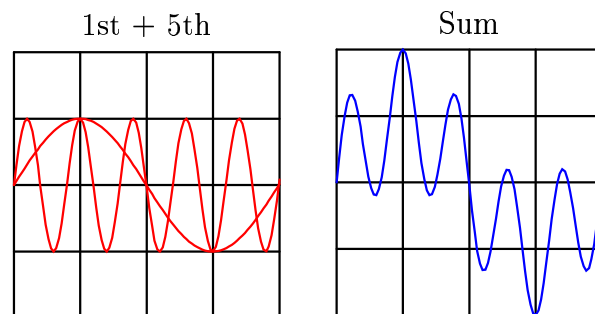
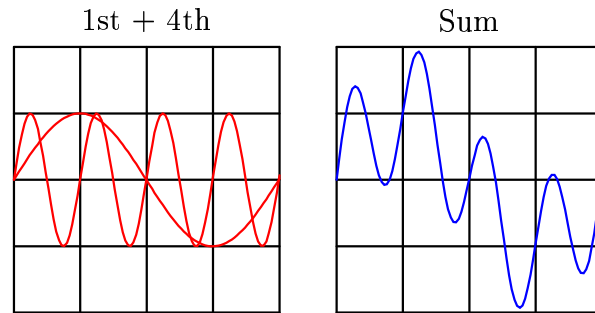

And again for the 1st + 6th, versus the 1st + 7th harmonics:



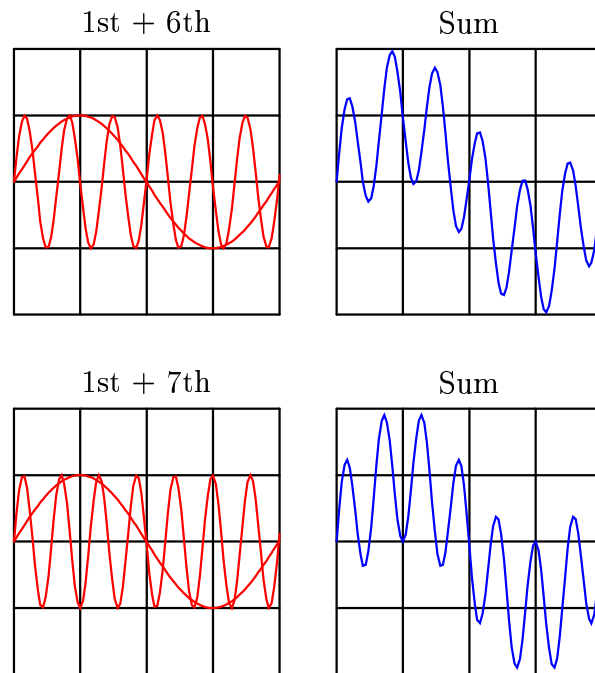

Examine these sets of harmonic sums, and indicate the trend you see with regard to harmonic number and symmetry of the final (Sum) waveforms. Specifically, how does the addition of an *even* harmonic compare to the addition of an *odd* harmonic, in terms of final waveshape?

[file 01892](#)

Question 12

When technicians and engineers consider harmonics in AC power systems, they usually only consider *odd-numbered* harmonic frequencies. Explain why this is.

[file 01893](#)

Question 13

By visual inspection, determine which of the following waveforms contain even-numbered harmonics:

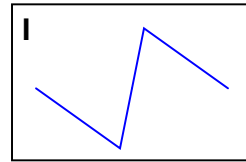
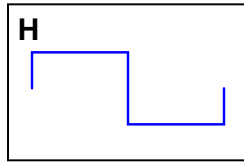
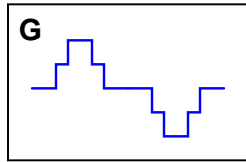
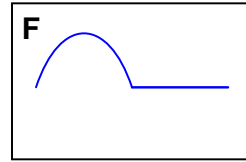
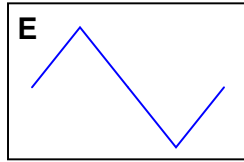
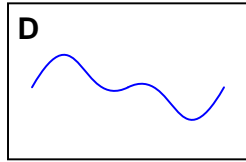
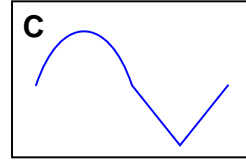
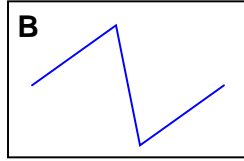
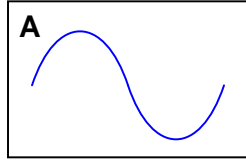

Note that only one cycle is shown for each waveform. Remember that we're dealing with continuous waveforms, endlessly repeating, and not single cycles as you see here.

[file 01894](#)

---

Question 14

Suppose an amplifier circuit is connected to a sine-wave signal generator, and a spectrum analyzer used to measure both the input and the output signals of the amplifier:

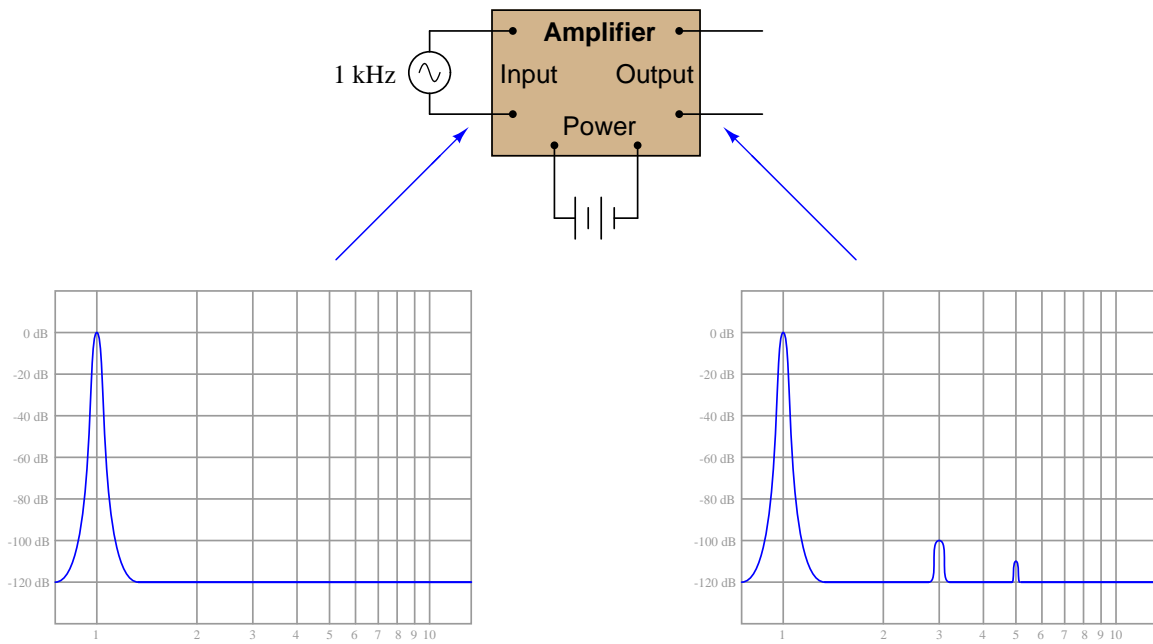

Interpret the two graphical displays and explain why the output signal has more "peaks" than the input. What is this difference telling us about the amplifier's performance?

[file 03307](#)

---

Question 15

A crude measurement circuit for harmonic content of a signal uses a notch filter tuned to the fundamental frequency of the signal being measured. Examine the following circuit and then explain how you think it would work:

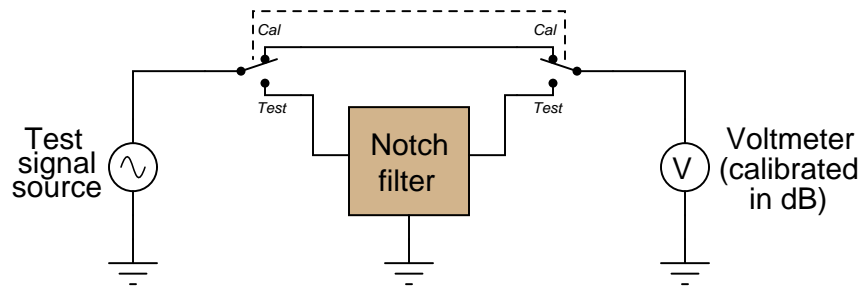

[file 03455](#)

---

Question 16

$\int f(x) dx$  Calculus alert!

Calculus is a branch of mathematics that originated with scientific questions concerning *rates of change*. The easiest rates of change for most people to understand are those dealing with time. For example, a student watching their savings account dwindle over time as they pay for tuition and other expenses is very concerned with rates of change (*dollars per year* being spent).

In calculus, we have a special word to describe rates of change: *derivative*. One of the notations used to express a derivative (rate of change) appears as a fraction. For example, if the variable  $S$  represents the amount of money in the student's savings account and  $t$  represents time, the rate of change of dollars over time would be written like this:

$$\frac{dS}{dt}$$

The following set of figures puts actual numbers to this hypothetical scenario:

- Date: November 20
- Saving account balance ( $S$ ) = \$12,527.33
- Rate of spending ( $\frac{dS}{dt}$ ) = -5,749.01 per year

List some of the equations you have seen in your study of electronics containing derivatives, and explain how *rate of change* relates to the real-life phenomena described by those equations.

[file 03310](#)

---

Question 17

$\int f(x) dx$  Calculus alert!

Define what "derivative" means when applied to the graph of a function. For instance, examine this graph:

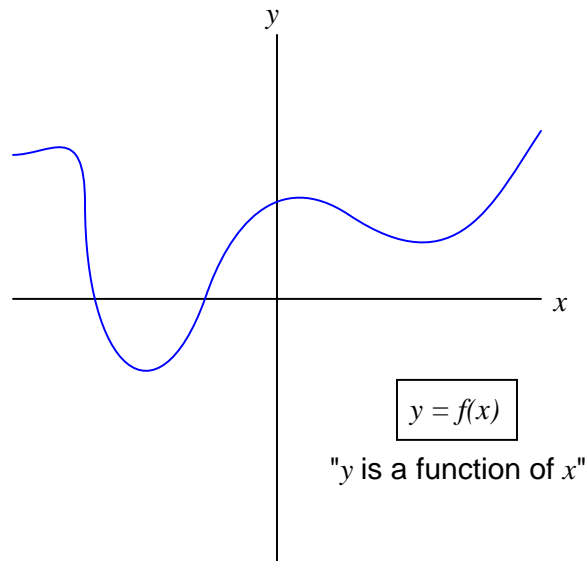

Label all the points where the derivative of the function ( $\frac{dy}{dx}$ ) is positive, where it is negative, and where it is equal to zero.

[file 03646](#)

---

Question 18

$\int f(x) dx$  *Calculus alert!*

Shown here is the graph for the function  $y = x^2$ :

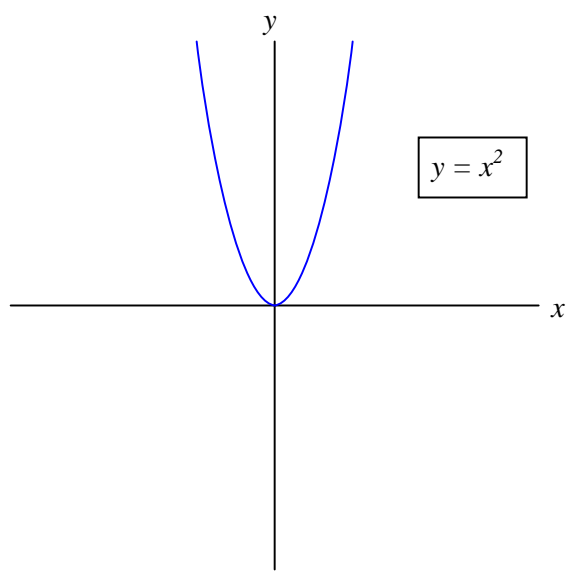

Sketch an approximate plot for the *derivative* of this function.

file 03647

Question 19

$\int f(x) dx$  Calculus alert!

According to the "Ohm's Law" formula for a capacitor, capacitor current is proportional to the *time-derivative* of capacitor voltage:

$$i = C \frac{dv}{dt}$$

Another way of saying this is to state that the capacitors *differentiate* voltage with respect to time, and express this *time-derivative* of voltage as a current.

Suppose we had an oscilloscope capable of directly measuring current, or at least a current-to-voltage converter that we could attach to one of the probe inputs to allow direct measurement of current on one channel. With such an instrument set-up, we could directly plot capacitor voltage and capacitor current together on the same display:

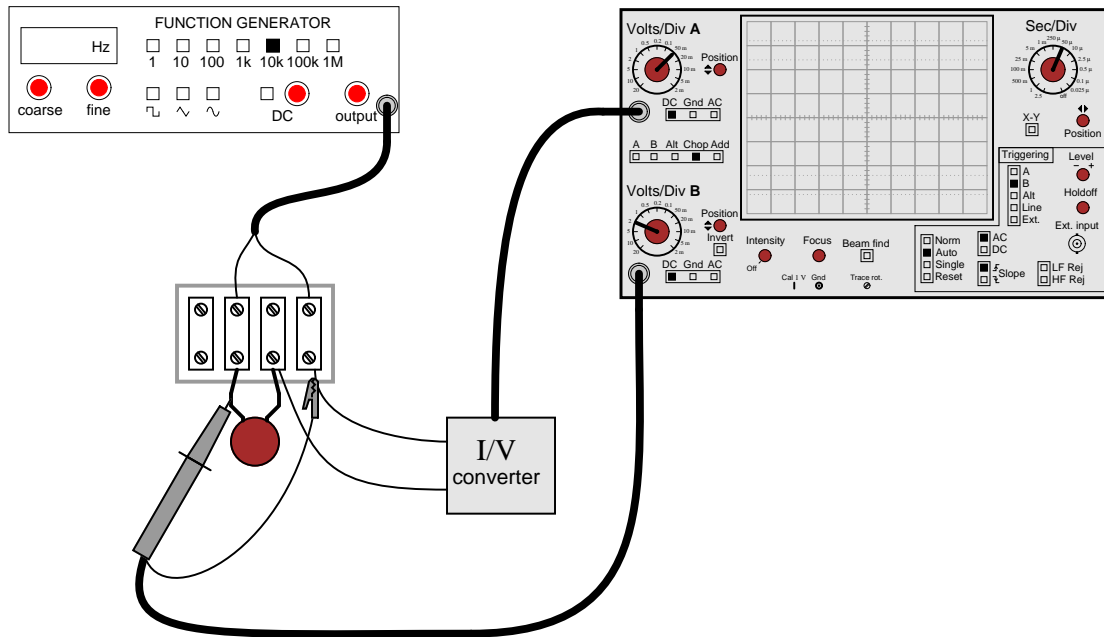

For each of the following voltage waveforms (channel B), plot the corresponding capacitor current waveform (channel A) as it would appear on the oscilloscope screen:

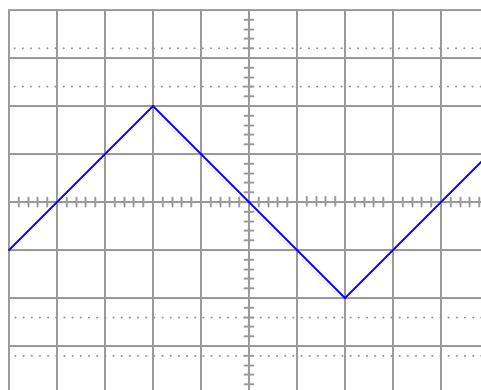

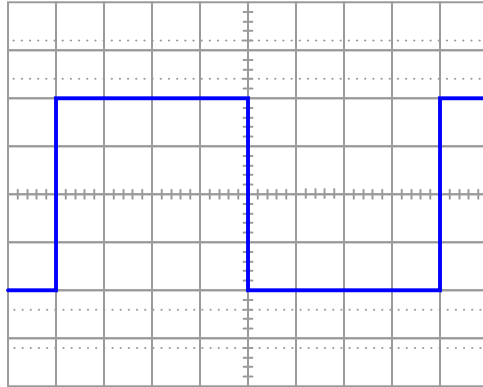
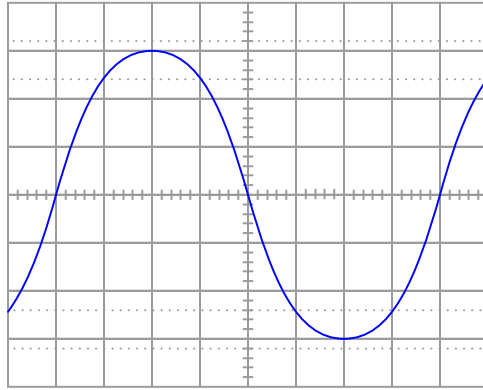

Note: the amplitude of your current plots is arbitrary. What I'm interested in here is the *shape* of each current waveform!  
[file 01900](#)

$\int f(x) dx$  Calculus alert!

According to the "Ohm's Law" formula for a capacitor, capacitor current is proportional to the *time-derivative* of capacitor voltage:

$$i = C \frac{dv}{dt}$$

Another way of saying this is to state that the capacitors *differentiate* voltage with respect to time, and express this *time-derivative* of voltage as a current.

We may build a simple circuit to produce an output voltage proportional to the current through a capacitor, like this:

*Passive differentiator circuit*

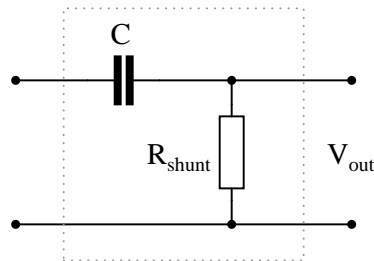

The resistor is called a *shunt* because it is designed to produce a voltage proportional to current, for the purpose of a parallel ("shunt")-connected voltmeter or oscilloscope to measure that current. Ideally, the shunt resistor is there only to help us measure current, and not to impede current through the capacitor. In other words, its value in ohms should be very small compared to the reactance of the capacitor ( $R_{shunt} \ll X_C$ ).

Suppose that we connect AC voltage sources with the following wave-shapes to the input of this passive differentiator circuit. Sketch the ideal (time-derivative) output waveform shape on each oscilloscope screen, as well as the shape of the actual circuit's output voltage (which will be non-ideal, of course):

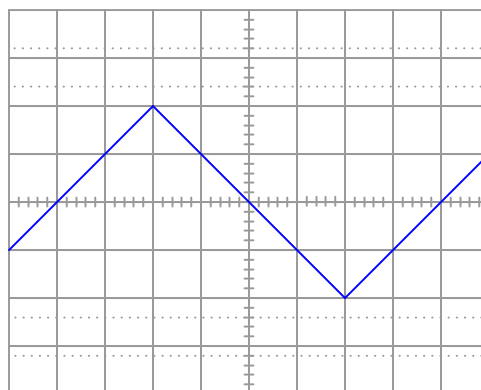



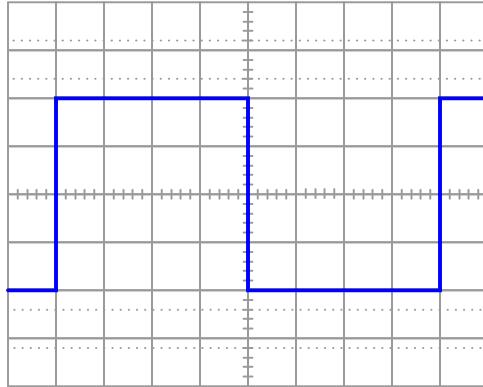
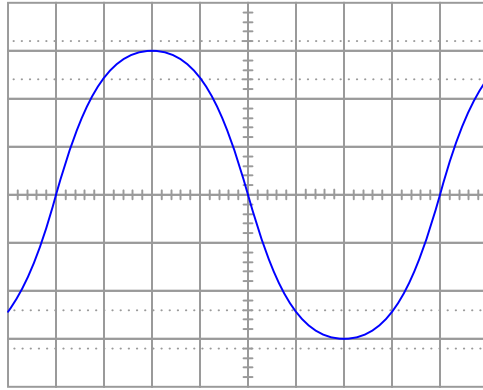

Note: the amplitude of your plots is arbitrary. What I'm interested in here is the *shape* of the ideal and actual output voltage waveforms!

Hint: I strongly recommend building this circuit and testing it with triangle, sine, and square-wave input voltage signals to obtain the corresponding actual output voltage wave-shapes!

[file 03643](#)

---

Question 21

$\int f(x) dx$  *Calculus alert!*

Calculus is widely (and falsely!) believed to be too complicated for the average person to understand. Yet, anyone who has ever driven a car has an intuitive grasp of calculus' most basic concepts: *differentiation* and *integration*. These two complementary operations may be seen at work on the instrument panel of every automobile:

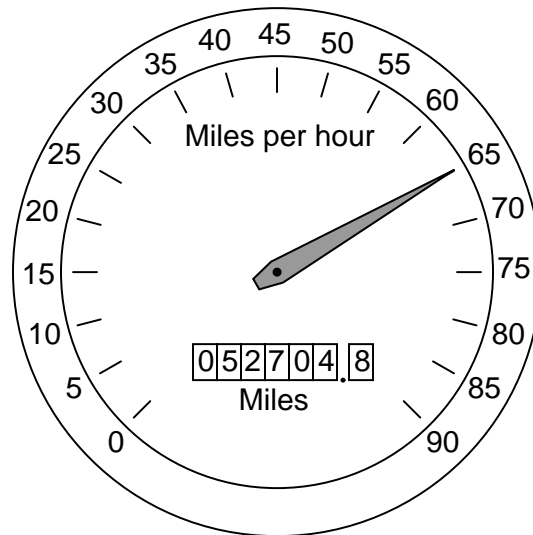

On this one instrument, two measurements are given: speed in miles per hour, and distance traveled in miles. In areas where metric units are used, the units would be kilometers per hour and kilometers, respectively. Regardless of units, the two variables of speed and distance are related to each other over time by the calculus operations of integration and differentiation. My question for you is which operation goes which way?

We know that speed is the rate of change of distance over time. This much is apparent simply by examining the units (miles *per hour* indicates a rate of change over time). Of these two variables, speed and distance, which is the *derivative* of the other, and which is the *integral* of the other? Also, determine what happens to the value of each one as the other maintains a constant (non-zero) value.

[file 03648](#)

Question 22

$\int f(x) dx$  Calculus alert!

Determine what the response will be to a constant DC voltage applied at the input of these (ideal) circuits:

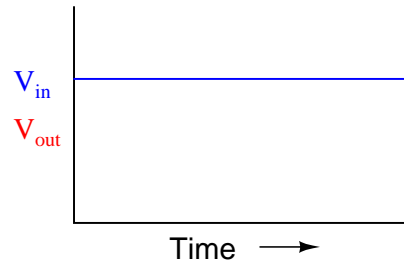
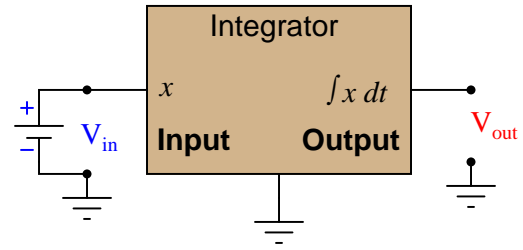
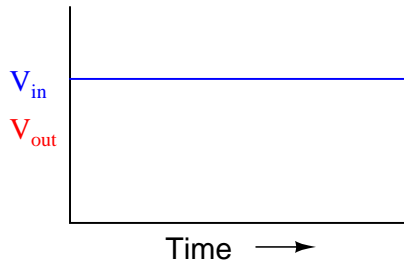
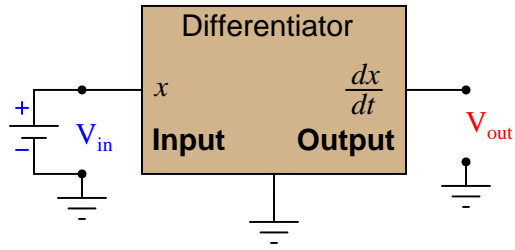

file 03649

Question 23

$\int f(x) dx$  Calculus alert!

In calculus, differentiation is the *inverse operation* of something else called *integration*. That is to say, differentiation "un-does" integration to arrive back at the original function (or signal). To illustrate this electronically, we may connect a differentiator circuit to the output of an integrator circuit and (ideally) get the exact same signal out that we put in:

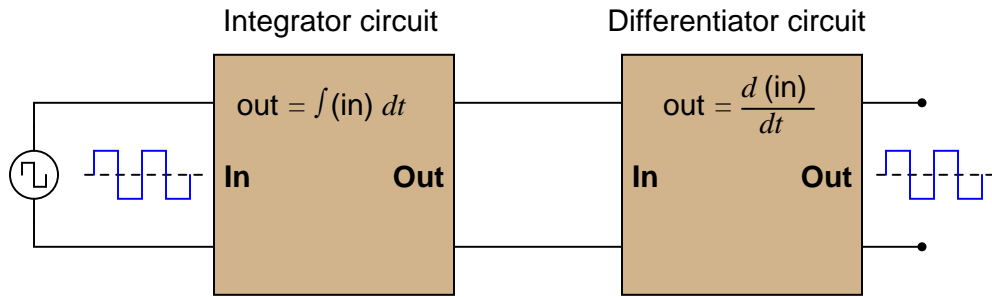

Based on what you know about differentiation and differentiator circuits, what must the signal look like in between the integrator and differentiator circuits to produce a final square-wave output? In other words, if we were to connect an oscilloscope in between these two circuits, what sort of signal would it show us?

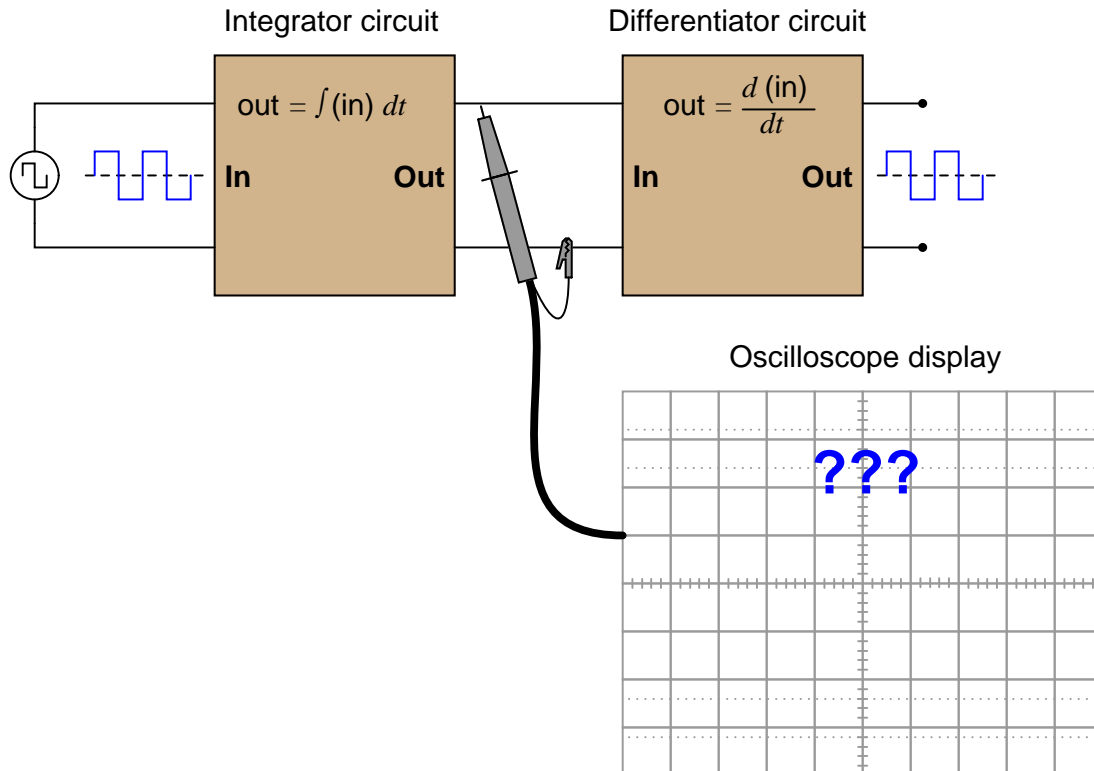

[file 03645](#)

---

Question 24

$\int f(x) dx$  *Calculus alert!*

Define what "integral" means when applied to the graph of a function. For instance, examine this graph:

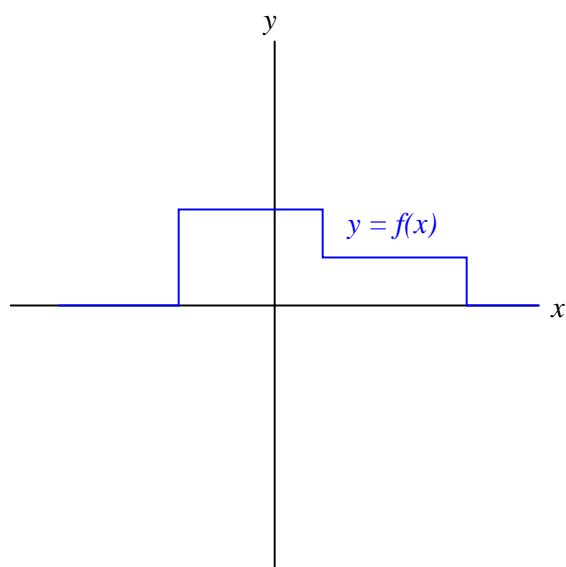

Sketch an approximate plot for the integral of this function.

[file 03650](#)

$\int f(x) dx$  *Calculus alert!*

If an object moves in a straight line, such as an automobile traveling down a straight road, there are three common measurements we may apply to it: *position* ( $x$ ), *velocity* ( $v$ ), and *acceleration* ( $a$ ). Position, of course, is nothing more than a measure of how far the object has traveled from its starting point. Velocity is a measure of how *fast* its position is changing over time. Acceleration is a measure of how fast the velocity is changing over time.

These three measurements are excellent illustrations of calculus in action. Whenever we speak of "rates of change," we are really referring to what mathematicians call *derivatives*. Thus, when we say that velocity ( $v$ ) is a measure of how fast the object's position ( $x$ ) is changing over time, what we are really saying is that velocity is the "time-derivative" of position. Symbolically, we would express this using the following notation:

$$v = \frac{dx}{dt}$$

Likewise, if acceleration ( $a$ ) is a measure of how fast the object's velocity ( $v$ ) is changing over time, we could use the same notation and say that acceleration is the time-derivative of velocity:

$$a = \frac{dv}{dt}$$

Since it took two differentiations to get from position to acceleration, we could also say that acceleration is the *second* time-derivative of position:

$$a = \frac{d^2x}{dt^2}$$

"What has this got to do with electronics," you ask? Quite a bit! Suppose we were to measure the velocity of an automobile using a tachogenerator sensor connected to one of the wheels: the faster the wheel turns, the more DC voltage is output by the generator, so that voltage becomes a direct representation of velocity. Now we send this voltage signal to the input of a *differentiator* circuit, which performs the time-differentiation function on that signal. What would the output of this differentiator circuit then represent with respect to the automobile, *position* or *acceleration*? What practical use do you see for such a circuit?

Now suppose we send the same tachogenerator voltage signal (representing the automobile's velocity) to the input of an *integrator* circuit, which performs the time-integration function on that signal (which is the mathematical inverse of differentiation, just as multiplication is the mathematical inverse of division). What would the output of this integrator then represent with respect to the automobile, *position* or *acceleration*? What practical use do you see for such a circuit?

[file 02696](#)

Question 26

$\int f(x) dx$  Calculus alert!

Potentiometers are very useful devices in the field of robotics, because they allow us to represent the position of a machine part in terms of a voltage. In this particular case, a potentiometer mechanically linked to the joint of a robotic arm represents that arm's angular position by outputting a corresponding voltage signal:

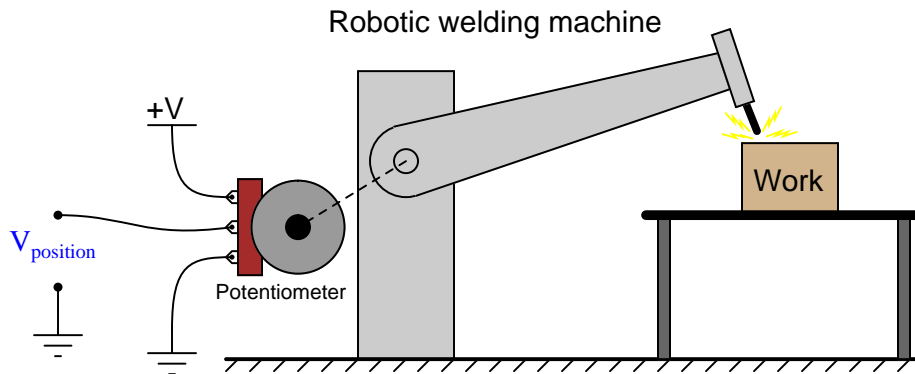

As the robotic arm rotates up and down, the potentiometer wire moves along the resistive strip inside, producing a voltage directly proportional to the arm's position. A voltmeter connected between the potentiometer wiper and ground will then indicate arm position. A computer with an analog input port connected to the same points will be able to measure, record, and (if also connected to the arm's motor drive circuits) control the arm's position.

If we connect the potentiometer's output to a *differentiator* circuit, we will obtain another signal representing something else about the robotic arm's action. What physical variable does the differentiator output signal represent?

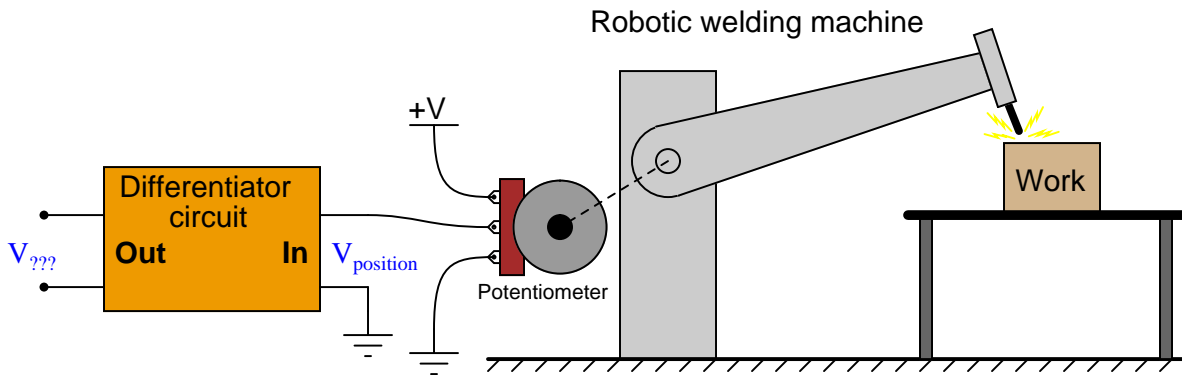

[file 03644](#)

---

Question 27

$\int f(x) dx$  Calculus alert!

A familiar context in which to apply and understand basic principles of calculus is the motion of an object, in terms of *position* ( $x$ ), *velocity* ( $v$ ), and *acceleration* ( $a$ ). We know that velocity is the time-derivative of position ( $v = \frac{dx}{dt}$ ) and that acceleration is the time-derivative of velocity ( $a = \frac{dv}{dt}$ ). Another way of saying this is that velocity is the rate of position change over time, and that acceleration is the rate of velocity change over time.

It is easy to construct circuits which input a voltage signal and output either the *time-derivative* or the *time-integral* (the opposite of the derivative) of that input signal. We call these circuits "differentiators" and "integrators," respectively.

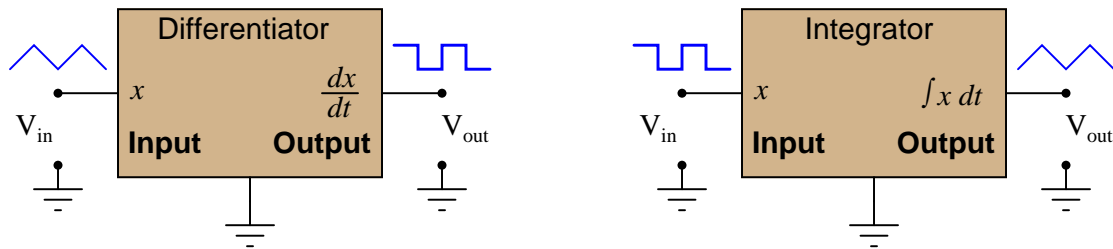

Integrator and differentiator circuits are highly useful for motion signal processing, because they allow us to take voltage signals from motion sensors and convert them into signals representing other motion variables. For each of the following cases, determine whether we would need to use an integrator circuit or a differentiator circuit to convert the first type of motion signal into the second:

- Converting velocity signal to position signal: (*integrator* or *differentiator*?)
- Converting acceleration signal to velocity signal: (*integrator* or *differentiator*?)
- Converting position signal to velocity signal: (*integrator* or *differentiator*?)
- Converting velocity signal to acceleration signal: (*integrator* or *differentiator*?)
- Converting acceleration signal to position signal: (*integrator* or *differentiator*?)

Also, draw the schematic diagrams for these two different circuits.

[file 02701](#)

---

Question 28

$\int f(x) dx$  Calculus alert!

You are part of a team building a rocket to carry research instruments into the high atmosphere. One of the variables needed by the on-board flight-control computer is velocity, so it can throttle engine power and achieve maximum fuel efficiency. The problem is, none of the electronic sensors on board the rocket has the ability to directly measure velocity. What is available is an *altimeter*, which infers the rocket's altitude (its position away from ground) by measuring ambient air pressure; and also an *accelerometer*, which infers acceleration (rate-of-change of velocity) by measuring the inertial force exerted by a small mass.

The lack of a "speedometer" for the rocket may have been an engineering design oversight, but it is still your responsibility as a development technician to figure out a workable solution to the dilemma. How do you propose we obtain the electronic velocity measurement the rocket's flight-control computer needs?

[file 02702](#)



$\int f(x) dx$  Calculus alert!

*Integrator* circuits may be understood in terms of their response to DC input signals: if an integrator receives a steady, unchanging DC input voltage signal, it will output a voltage that changes with a steady *rate* over time. The rate of the changing output voltage is directly proportional to the magnitude of the input voltage:

### Typical integrator response

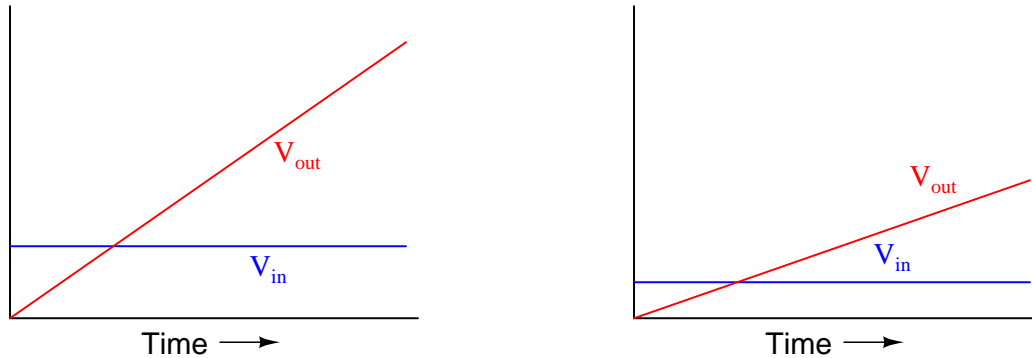

A symbolic way of expressing this input/output relationship is by using the concept of the *derivative* in calculus (a rate of change of one variable compared to another). For an integrator circuit, the rate of output voltage change over time is proportional to the input voltage:

$$\frac{dV_{out}}{dt} \propto V_{in}$$

A more sophisticated way of saying this is, "The time-derivative of output voltage is proportional to the input voltage in an integrator circuit." However, in calculus there is a special symbol used to express this same relationship in reverse terms: expressing the output voltage as a function of the input. For an integrator circuit, this special symbol is called the *integration* symbol, and it looks like an elongated letter "S":

$$V_{out} \propto \int_0^T V_{in} dt$$

Here, we would say that output voltage is proportional to the time-integral of the input voltage, accumulated over a period of time from time=0 to some point in time we call  $T$ .

"This is all very interesting," you say, "but what does this have to do with anything in real life?" Well, there are actually a great deal of applications where physical quantities are related to each other by time-derivatives and time-integrals. Take this water tank, for example:

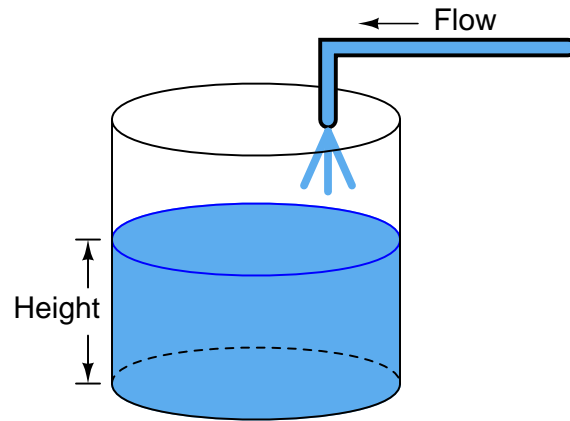

One of these variables (either height  $H$  or flow  $F$ , I'm not saying yet!) is the time-integral of the other, just as  $V_{out}$  is the time-integral of  $V_{in}$  in an integrator circuit. What this means is that we could electrically measure one of these two variables in the water tank system (either height or flow) so that it becomes represented as a voltage, then send that voltage signal to an integrator and have the output of the integrator *derive* the other variable in the system without having to measure it!

Your task is to determine which variable in the water tank scenario would have to be measured so we could electronically predict the other variable using an integrator circuit.

[file 02695](#)

Question 30

$\int f(x) dx$  Calculus alert!

A *Rogowski Coil* is essentially an air-core current transformer that may be used to measure DC currents as well as AC currents. Like all current transformers, it measures the current going through whatever conductor(s) it encircles.

Normally transformers are considered AC-only devices, because electromagnetic induction requires a *changing* magnetic field ( $\frac{d\phi}{dt}$ ) to induce voltage in a conductor. The same is true for a Rogowski coil: it produces a voltage only when there is a change in the measured current. However, we may measure any current (DC or AC) using a Rogowski coil if its output signal feeds into an integrator circuit as shown:

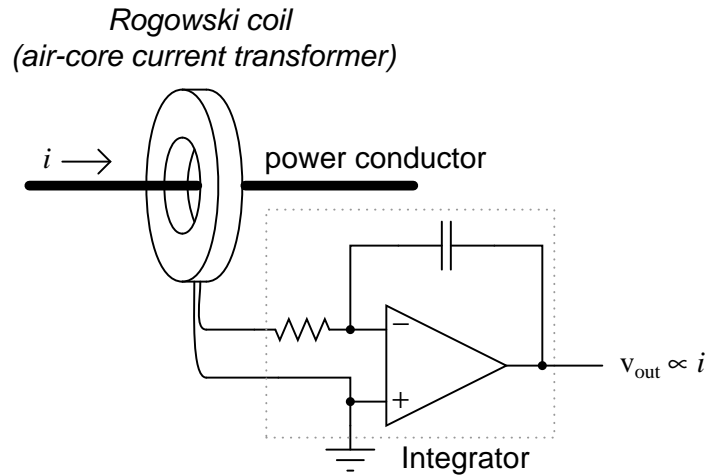

Connected as such, the output of the integrator circuit will be a direct representation of the amount of current going through the wire.

Explain why an integrator circuit is necessary to condition the Rogowski coil's output so that output voltage truly represents conductor current.

file 01009

---

Question 31

Generally speaking, how many "time constants" worth of time does it take for the voltage and current to "settle" into their final values in an RC or LR circuit, from the time the switch is closed?

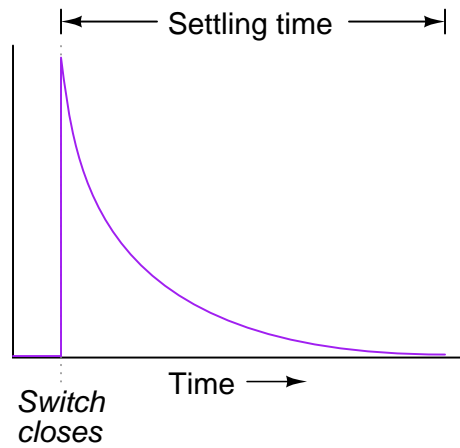

file 00437

---

Question 32

Plot the output waveform of a passive differentiator circuit, assuming the input is a symmetrical square wave and the circuit's RC time constant is about one-fifth of the square wave's pulse width:

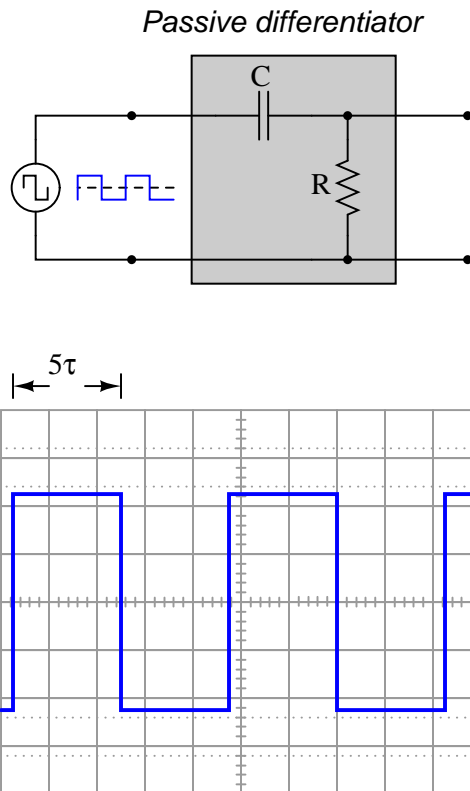

file 02052

---

Question 33

It is relatively easy to design and build an electronic circuit to make square-wave voltage signals. More difficult to engineer is a circuit that directly generates triangle-wave signals. A common approach in electronic design when triangle waves are needed for an application is to connect a *passive integrator* circuit to the output of a square-wave oscillator, like this:

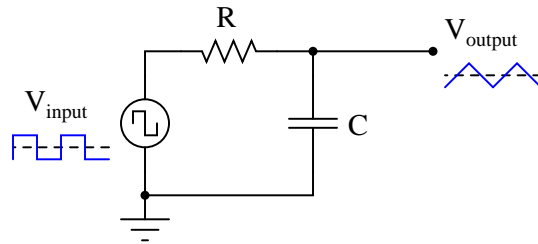

Anyone familiar with RC circuits will realize, however, that a passive integrator will not output a true triangle wave, but rather it will output a waveshape with "rounded" leading and trailing edges:

*True triangle wave*

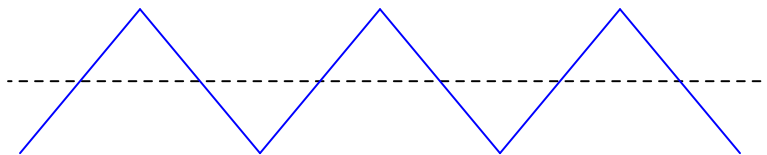

*Passive integrator output*

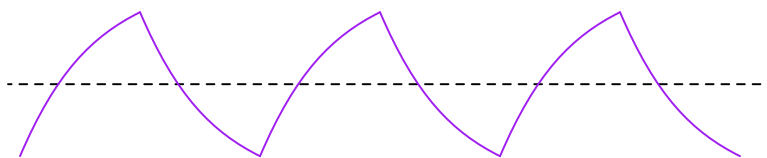

What can be done with the values of  $R$  and  $C$  to best approximate a true triangle wave? What variable must be compromised to achieve the most linear edges on the integrator output waveform? Explain why this is so.

[file 01896](#)

---

Question 34

Design a passive integrator circuit using a resistor and *inductor* rather than a resistor and capacitor:

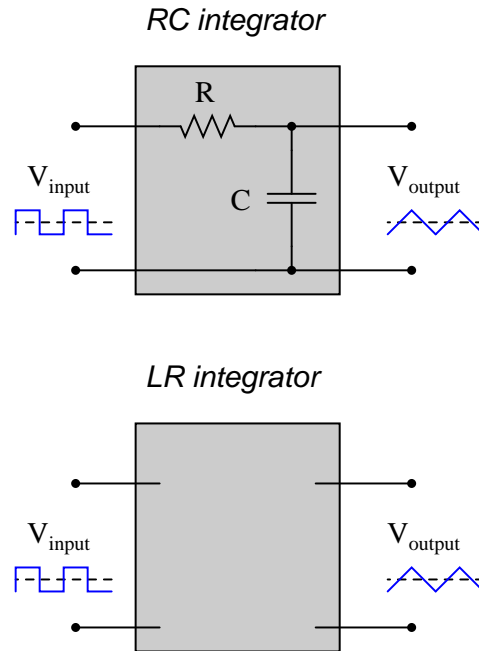

In addition to completing the inductor circuit schematic, qualitatively state the preferred values of  $L$  and  $R$  to achieve an output waveform most resembling a true triangle wave. In other words, are we looking for a large or small inductor; a large or small resistor?

[file 01897](#)

---

Question 35

Complete the following sentences with one of these phrases: "shorter than," "longer than," or "equal to". Then, explain why the time constant of each circuit type must be so.

Passive integrator circuits should have time constants that are (*fill-in-the-blank*) the period of the waveform being integrated.

Passive differentiator circuits should have time constants that are (*fill-in-the-blank*) the period of the waveform being differentiated.

[file 01901](#)

---

Question 36

When you look at the schematic diagram for a passive integrator circuit, it ought to remind you of another type of circuit you've seen before: a *passive filter* circuit:

*Passive integrator or passive filter?*

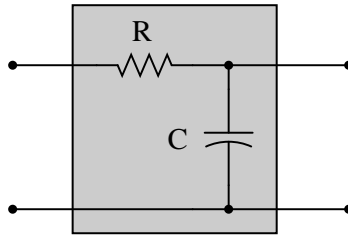

What specific type of passive filter does a passive integrator circuit resemble? Is the resemblance the same for LR integrators as well, or just RC integrators? What does this resemblance tell you about the frequency response of a passive integrator circuit?

[file 01898](#)

---

Question 37

A "cheap" way to electronically produce waveforms resembling sine waves is to use a pair of passive integrator circuits, one to convert square waves into pseudo-triangle waves, and the next to convert pseudo-triangle waves into pseudo-sine waves:

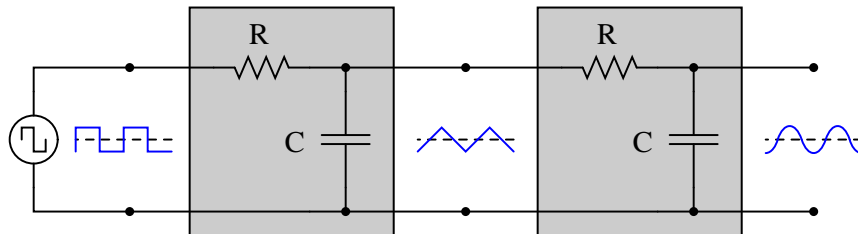

From Fourier's theory, we know that a square wave is nothing more than a series of sinusoidal waveforms: the fundamental frequency plus all odd harmonics at diminishing amplitudes. Looking at the two integrators as *passive filter circuits*, explain how it is possible to get a pseudo-sine wave from a square wave input as shown in the above diagram. Also, explain why the final output is not a true sine wave, but only resembles a sine wave.

[file 01899](#)

Question 38

The following two expressions are frequently used to calculate values of changing variables (voltage and current) in RC and LR timing circuits:

$$e^{-\frac{t}{\tau}} \quad \text{or} \quad 1 - e^{-\frac{t}{\tau}}$$

One of these expressions describes the percentage that a changing value in an RC or LR circuit *has gone* from the starting time. The other expression describes how far that same variable *has left to go* before it reaches its ultimate value (at  $t = \infty$ ).

The question is, which expression represents which quantity? This is often a point of confusion, because students have a tendency to try to correlate these expressions to the quantities by rote memorization. Does the expression  $e^{-\frac{t}{\tau}}$  represent the amount a variable has changed, or how far it has left to go until it stabilizes? What about the other expression  $1 - e^{-\frac{t}{\tau}}$ ? More importantly, *how can we figure this out so we don't have to rely on memory?*

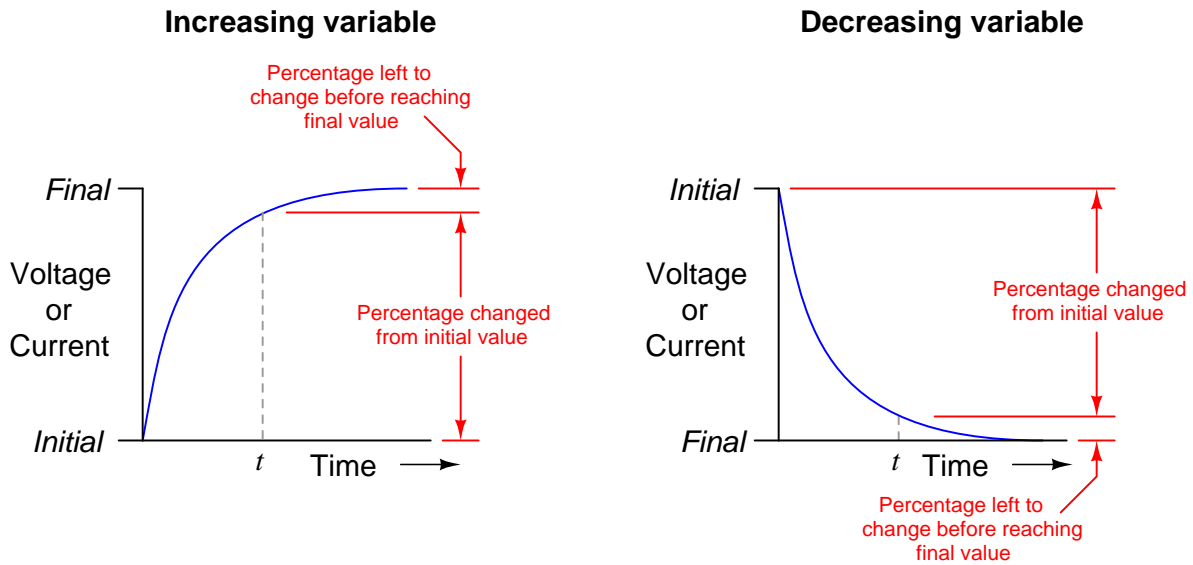

file 03117



Question 39

Determine the capacitor voltage at the specified times (time  $t = 0$  milliseconds being the exact moment the switch contacts close). Assume the capacitor begins in a fully discharged state:

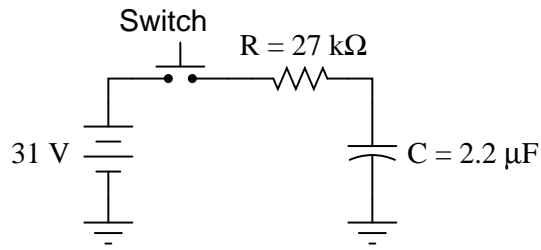

Time	$V_C$ (volts)
0 ms	
30 ms	
60 ms	
90 ms	
120 ms	
150 ms	

[file 03555](#)

Question 40

Calculate the output voltage of this passive differentiator circuit 1 millisecond after the rising edge of each positive square wave pulse (where the square wave transitions from -5 volts to +5 volts):

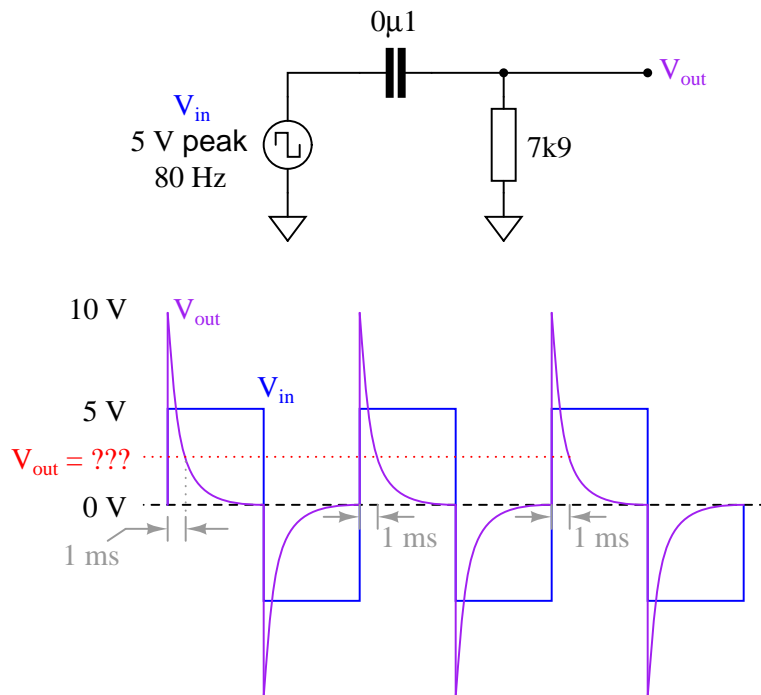

[file 03652](#)

---

Question 41

Calculate the output voltage of this passive differentiator circuit 150 microseconds after the rising edge of each "clock" pulse (where the square wave transitions from 0 volts to +5 volts):

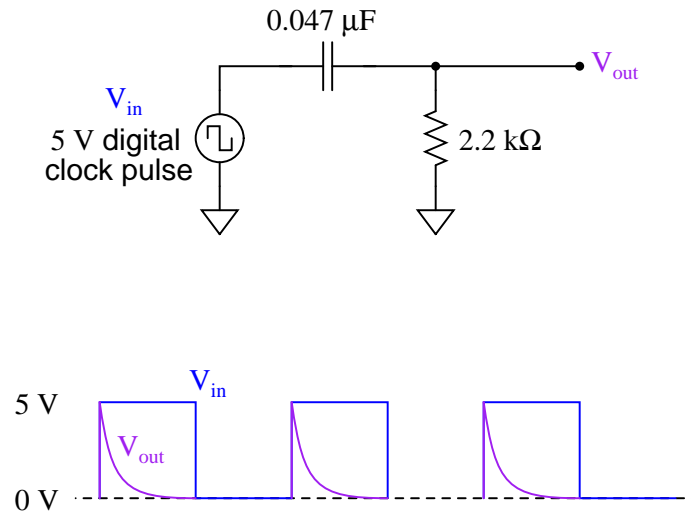

[file 03654](#)

---

Question 42

A passive differentiator is used to "shorten" the pulse width of a square wave by sending the differentiated signal to a "level detector" circuit, which outputs a "high" signal (+5 volts) whenever the input exceeds 3.5 volts and a "low" signal (0 volts) whenever the input drops below 3.5 volts:

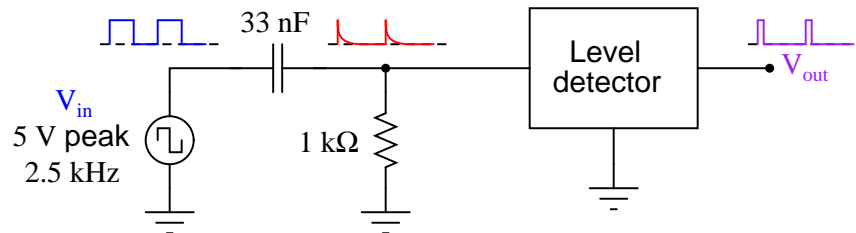

Each time the differentiator's output voltage signal spikes up to +5 volts and quickly decays to 0 volts, it causes the level detector circuit to output a narrow voltage pulse, which is what we want.

Calculate how wide this final output pulse will be if the input (square wave) frequency is 2.5 kHz.

[file 03653](#)

Question 43

Assume that the switch in this circuit is toggled (switched positions) once every 5 seconds, beginning in the "up" (charge) position at time  $t = 0$ , and that the capacitor begins in a fully discharged state at that time. Determine the capacitor voltage at each switch toggle:

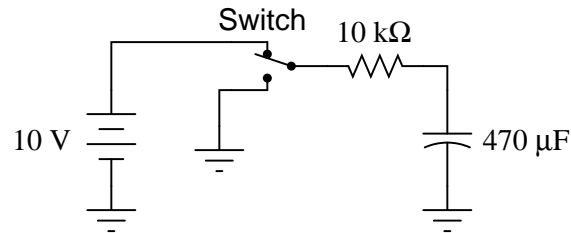

Time	Switch motion	$V_C$ (volts)
0 s	discharge $\rightarrow$ charge	0 volts
5 s	charge $\rightarrow$ discharge	
10 s	discharge $\rightarrow$ charge	
15 s	charge $\rightarrow$ discharge	
20 s	discharge $\rightarrow$ charge	
25 s	charge $\rightarrow$ discharge	

[file 03668](#)

Question 44

This passive integrator circuit is powered by a square-wave voltage source (oscillating between 0 volts and 5 volts at a frequency of 2 kHz). Determine the output voltage ( $v_{out}$ ) of the integrator at each instant in time where the square wave transitions (goes from 0 to 5 volts, or from 5 to 0 volts), assuming that the capacitor begins in a fully discharged state at the first transition (from 0 volts to 5 volts):

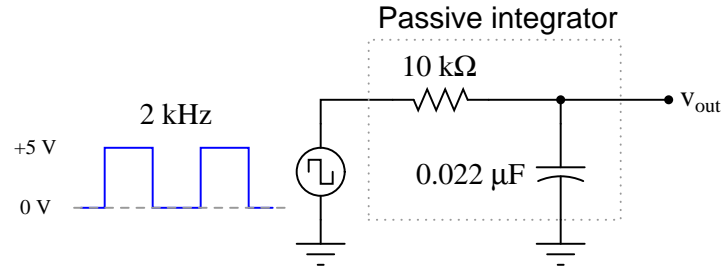

Transition	$v_{out}$
#1 (0 $\rightarrow$ 5 volts)	0 volts
#2 (5 $\rightarrow$ 0 volts)	
#3 (0 $\rightarrow$ 5 volts)	
#4 (5 $\rightarrow$ 0 volts)	
#5 (0 $\rightarrow$ 5 volts)	
#6 (5 $\rightarrow$ 0 volts)	
#7 (0 $\rightarrow$ 5 volts)	
#8 (5 $\rightarrow$ 0 volts)	

[file 03669](#)

Question 45

A passive integrator circuit is energized by a square wave signal with a peak-to-peak amplitude of 12 volts and a frequency of 65.79 Hz:

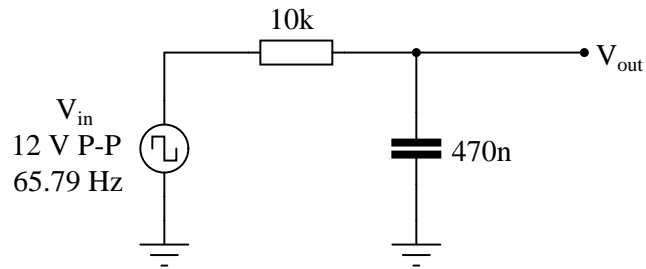

Determine the peak-to-peak voltage of the output waveform:

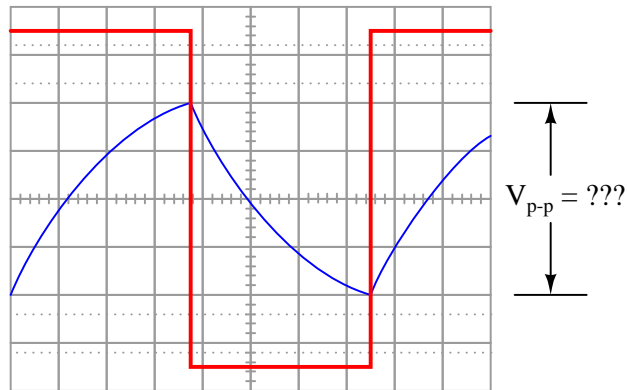

Hint: the output waveform will be centered exactly half-way between the two peaks of the input square wave as shown in the oscilloscope image. Do *not* base your answer on relative sizes of the two waveforms, as I have purposely skewed the calibration of the oscilloscope screen image so the two waveforms are not to scale with each other.

[file 03308](#)

---

Question 46

A very useful tool for observing rotating objects is a *strobe light*. Basically, a strobe light is nothing more than a very bright flash bulb connected to an electronic pulse generating circuit. The flash bulb periodically emits a bright, brief pulse of light according to the frequency set by the pulse circuit. By setting the period of a strobe light to the period of a rotating object (so the bulb flashes once per revolution of the object), the object will appear to any human observer to be still rather than rotating:

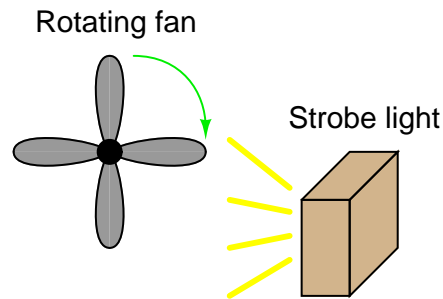

One problem with using a strobe light is that the frequency of the light pulses must exactly match the frequency of the object's rotation, or else the object will not appear to stand still. If the flash rate is mismatched, even by the slightest amount, the object will appear to *slowly* rotate instead of stand still.

Analog (CRT-based) oscilloscopes are similar in principle. A repetitive waveform appears to "stand still" on the screen despite the fact that the trace is made by a bright dot of light constantly moving across the screen (moving up and down with voltage, and sweeping left to right with time). Explain how the sweep rate of an oscilloscope is analogous to the flash rate of a strobe light.

If an analog oscilloscope is placed in the "free-run" mode, it will exhibit the same frequency mismatch problem as the strobe light: if the sweep rate is not *precisely* matched to the period of the waveform being displayed (or some integer multiple thereof), the waveform will appear to *slowly* scroll horizontally across the oscilloscope screen. Explain why this happens.

[file 01904](#)

---

Question 47

Suppose a metal-detecting sensor were connected to a strobe light, so that the light flashed every time a fan blade passed by the sensor. How would this setup differ in operation from one where the strobe light is free-running?

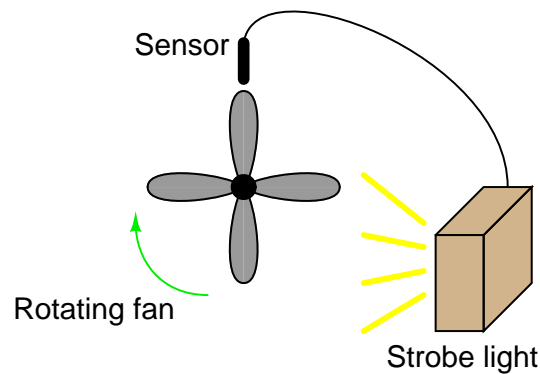

[file 01918](#)

Question 48

The only way to consistently guarantee a repetitive waveform will appear "still" on an analog oscilloscope screen is for each left-to-right sweep of the CRT's electron beam to begin at the same point on the waveform. Explain how the "trigger" system on an oscilloscope works to accomplish this.

[file 01905](#)

Question 49

On this oscilloscope, identify the location of the trigger level control, and explain what it does:

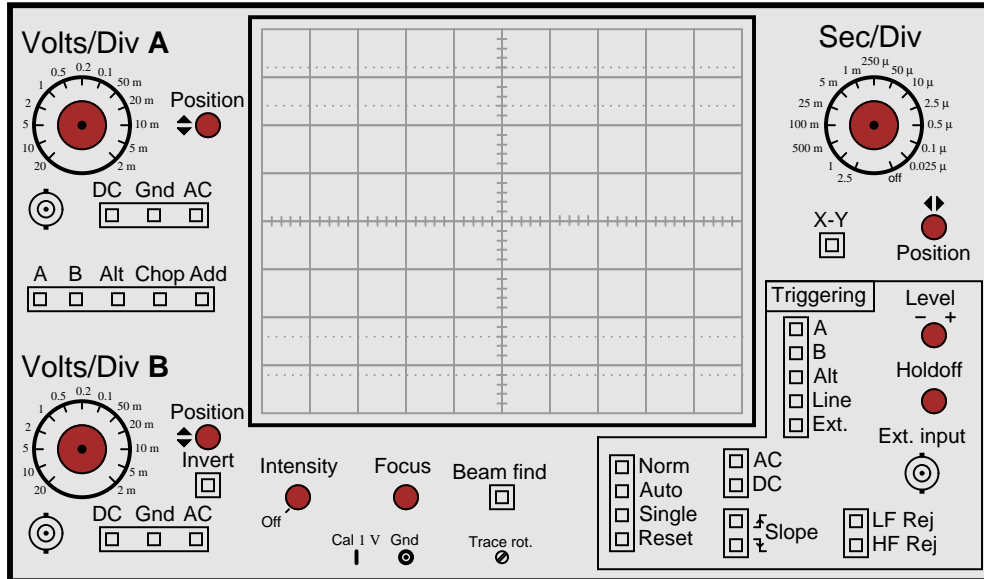

[file 01906](#)

Question 50

Suppose an oscilloscope has been set up to display a triangle wave:

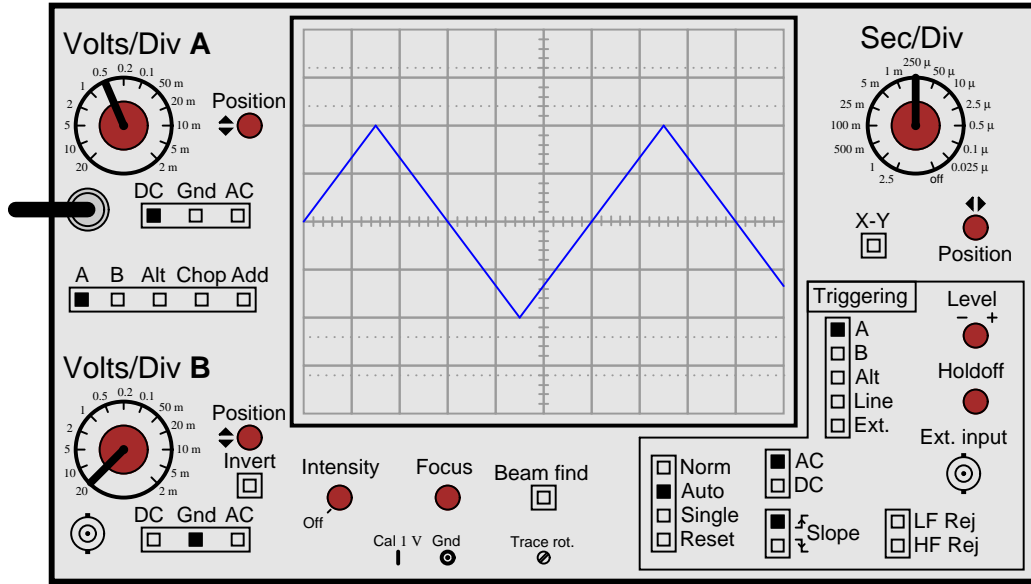

The horizontal position knob is then turned clockwise until the left-hand edge of the waveform is visible:

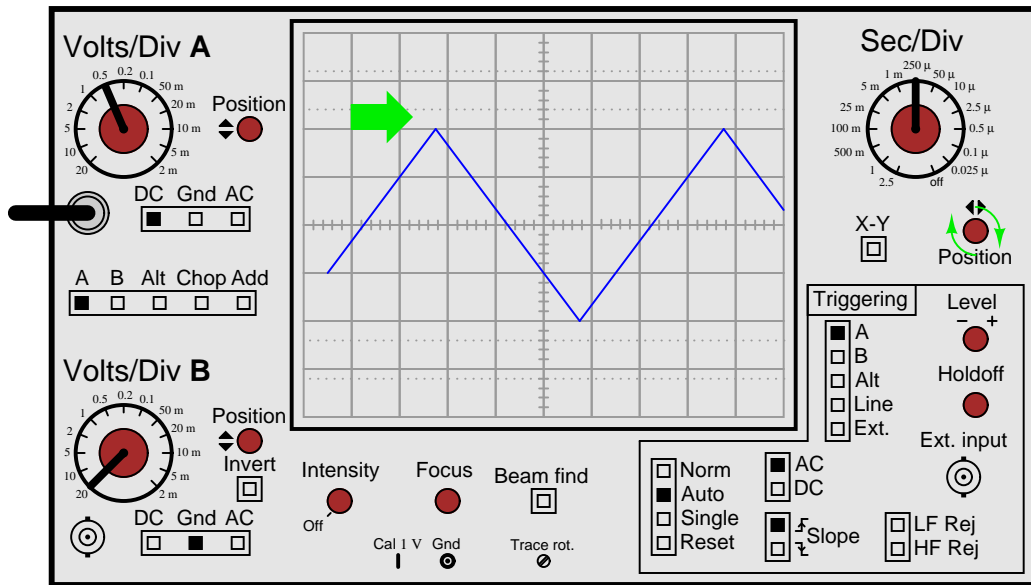

Now, the point at which the waveform triggers is clearly visible, no longer hidden from view past the left-hand side of the screen:

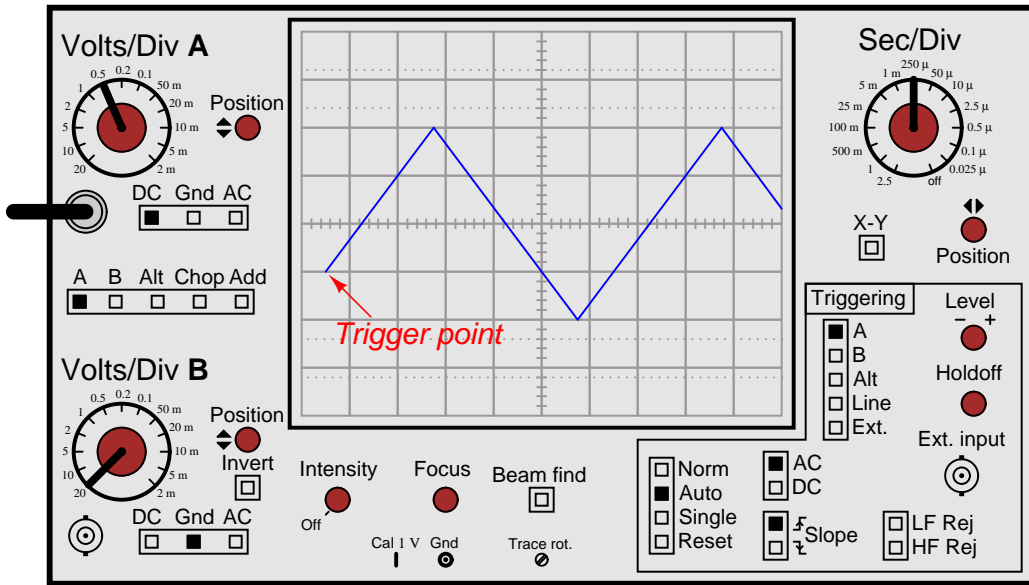

What will happen now if the trigger level knob is turned clockwise? How will this affect the positioning of the waveform on the oscilloscope screen?

[file 01907](#)



Question 51

Suppose an oscilloscope has been set up to display a triangle wave, with the horizontal position control turned clockwise until the left-hand edge of the waveform is visible:

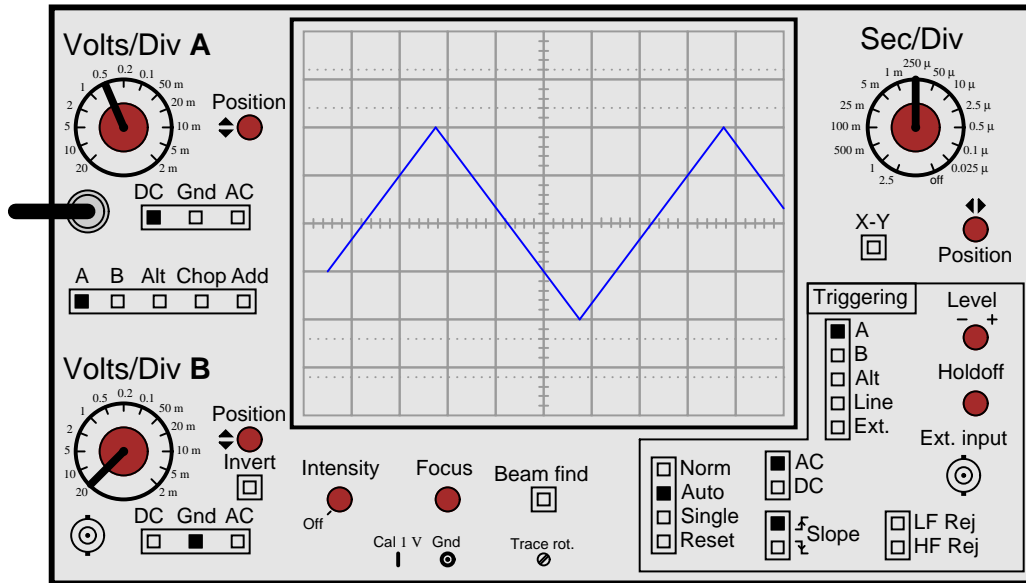

Then, the technician changes the slope control, changing it from "increasing" to "decreasing":

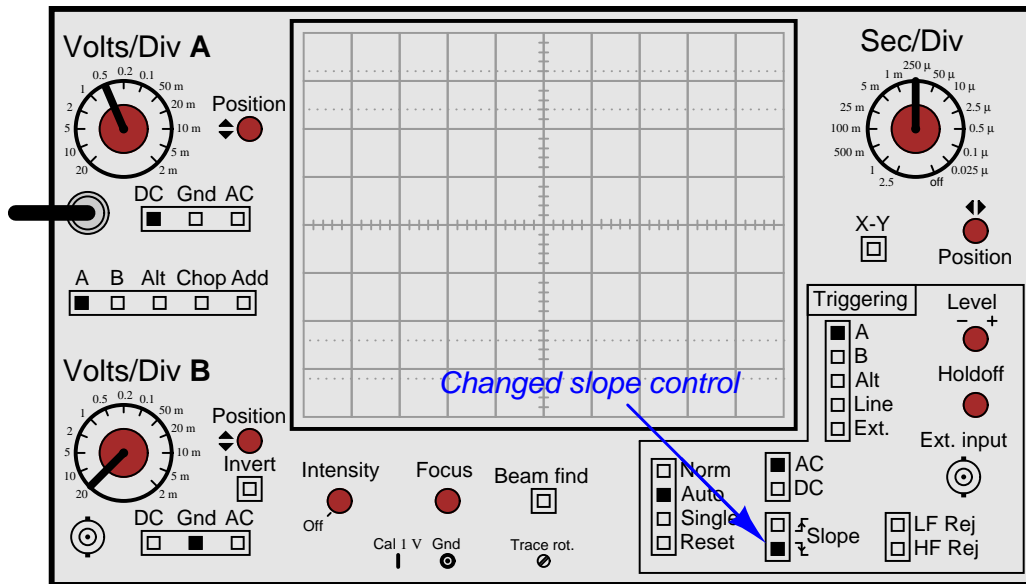

Draw the waveform's new appearance on the oscilloscope screen, with the slope control reversed.  
[file 01908](#)



Question 54

Large electric motors and other pieces of rotating machinery are often equipped with *vibration sensors* to detect imbalances. These sensors are typically linked to an automatic shutdown system so that the machine will turn itself off if the sensors detect excessive vibration.

Some of the more popular industrial-grade sensors generate a DC voltage proportional to the physical distance between the end of the sensor and the nearest metallic surface. A typical sensor installation might look like this:

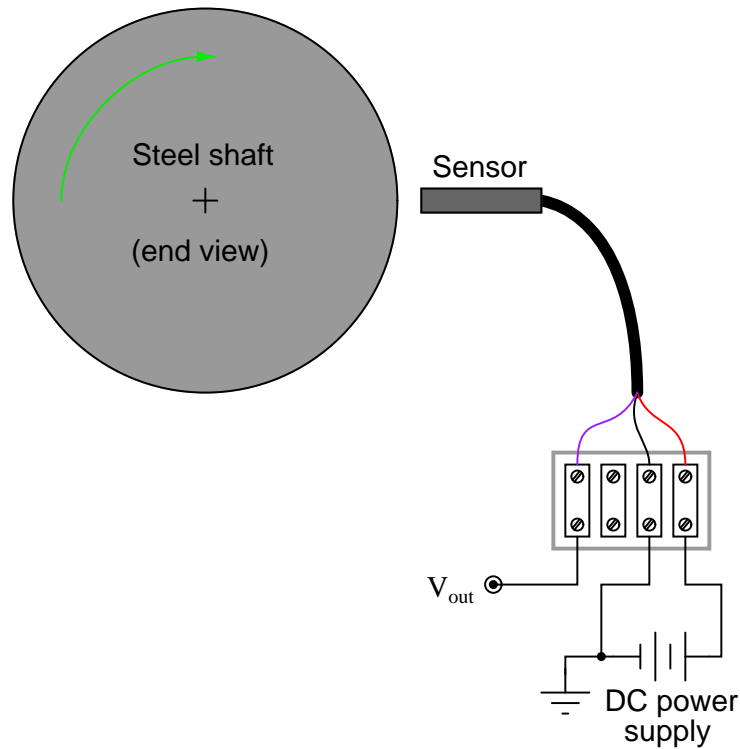

If the machine is running smoothly (or if it is shut down and not turning at all), the output voltage from the sensor will be pure DC, indicating a constant distance between the sensor end and the shaft surface. On the other hand, if the shaft becomes imbalanced it will bend ever so slightly, causing the distance to the sensor tip to periodically fluctuate as it rotates beneath the sensor. The result will be a sensor output signal that is an AC "ripple" superimposed on a DC bias, the frequency of that ripple voltage being equal to the frequency of the shaft's rotation:

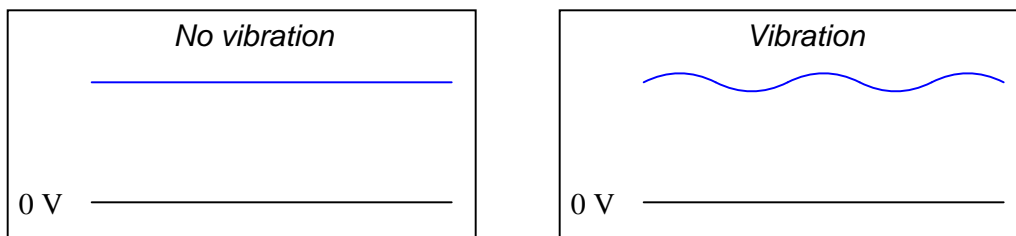

The vibration sensing circuitry measures the amplitude of this ripple and initiates a shutdown if it exceeds a pre-determined value.

An additional sensor often provided on large rotating machines is a *sync pulse* sensor. This sensor works just like the other vibration sensors, except that it is intentionally placed in such a position that it "sees"

a keyway or other irregularity on the rotating shaft surface. Consequently, the "sync" sensor outputs a square-wave "notch" pulse, once per shaft revolution:

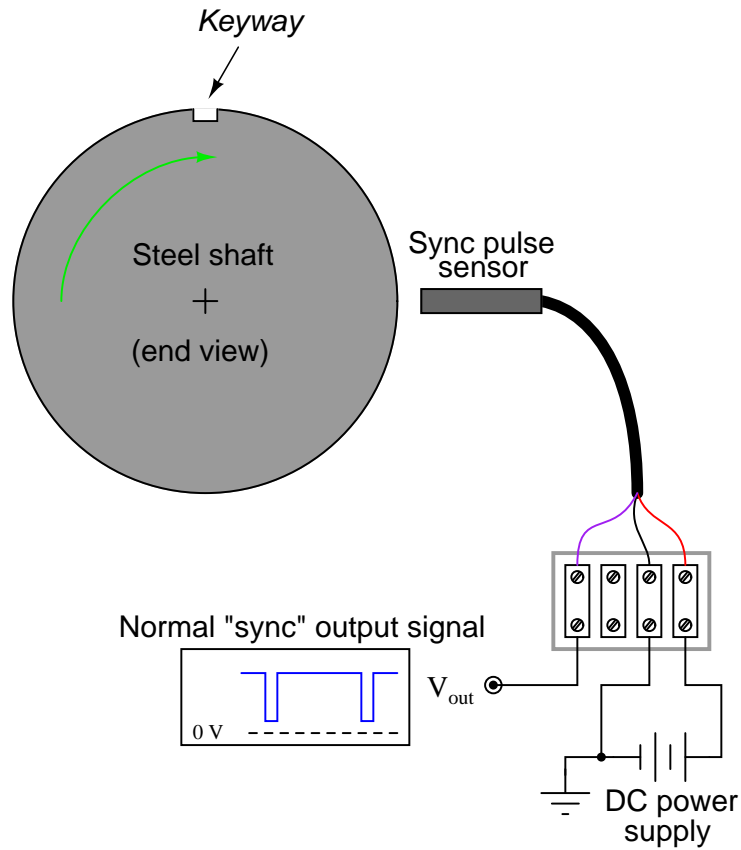

The purpose of this "sync" pulse is to provide an angular reference point, so any vibration peaks seen on any of the other sensor signals may be located relative to the sync pulse. This allows a technician or engineer to determine *where* in the shaft's rotation any peaks are originating.

Your question is this: explain how you would use the sync pulse output to trigger an oscilloscope, so that every sweep of the electron beam across the oscilloscope's screen begins at that point in time.

[file 01912](#)

Question 55

A student is trying to measure an AC waveform superimposed on a DC voltage, output by the following circuit:

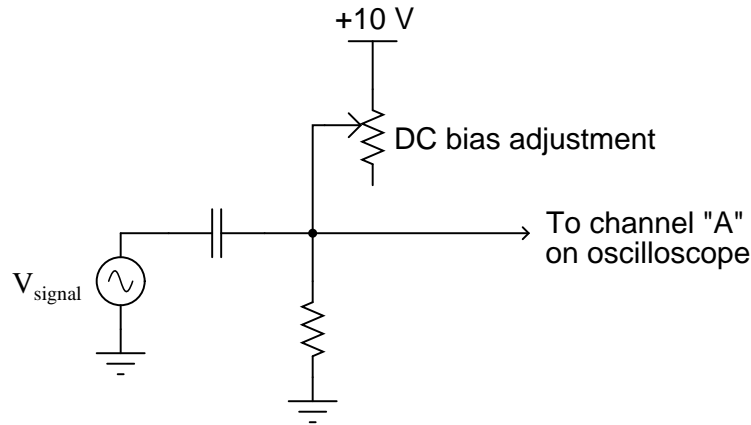

The problem is, every time the student moves the circuit's DC bias adjustment knob, the oscilloscope loses its triggering and the waveform begins to wildly scroll across the width of the screen. In order to get the oscilloscope to trigger on the AC signal again, the student must likewise move the trigger level knob on the oscilloscope panel. Inspect the settings on the student's oscilloscope (shown here) and determine what could be configured differently to achieve consistent triggering so the student won't have to re-adjust the trigger level every time she re-adjusts the circuit's DC bias voltage:

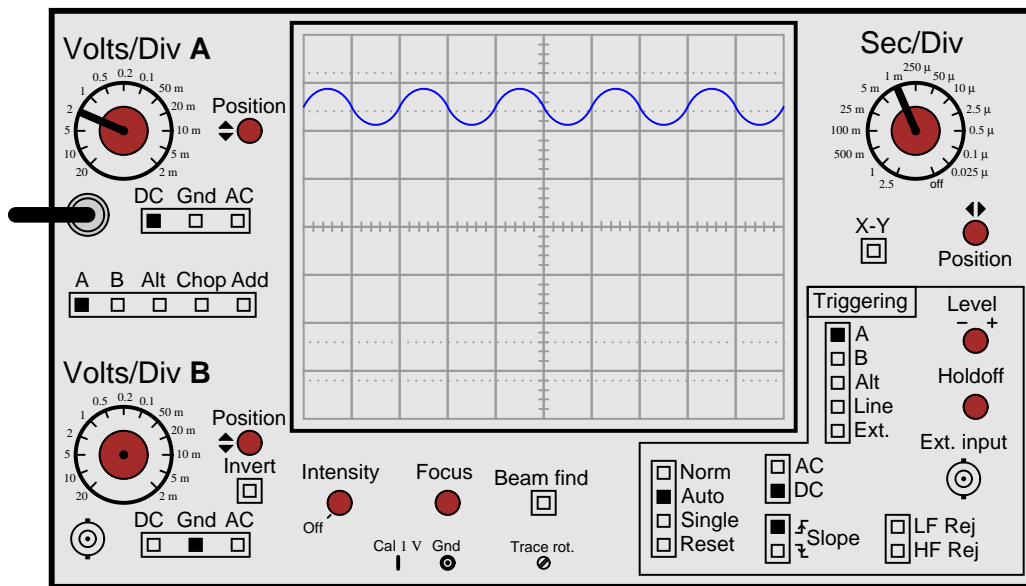

[file 01919](#)

Question 56

A student wants to measure the "ripple" voltage from an AC-DC power supply. This is the small AC voltage superimposed on the DC output of the power supply, that is a natural consequence of AC-to-DC conversion. In a well-designed power supply, this "ripple" voltage is minimal, usually in the range of millivolts peak-to-peak even if the DC voltage is 20 volts or more. Displaying this "ripple" voltage on an oscilloscope can be quite a challenge to the new student.

This particular student already knows about the AC/DC coupling controls on the oscilloscope's input. Set to the "DC" coupling mode, the ripple is a barely-visible squiggle on an otherwise straight line:

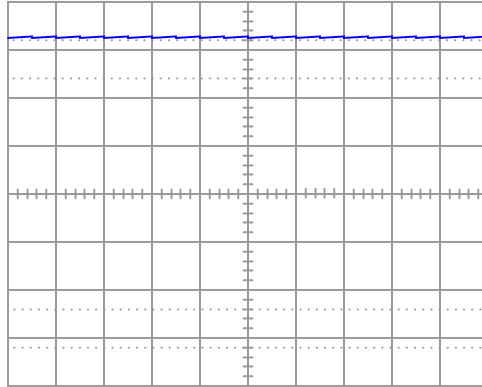

After switching the input channel's coupling control to "AC", the student increases the vertical sensitivity (fewer volts per division) to magnify the ripple voltage. The problem is, the ripple waveform is not engaging the oscilloscope's triggering. Instead, all the student sees is a blur as the waveform quickly scrolls horizontally on the screen:

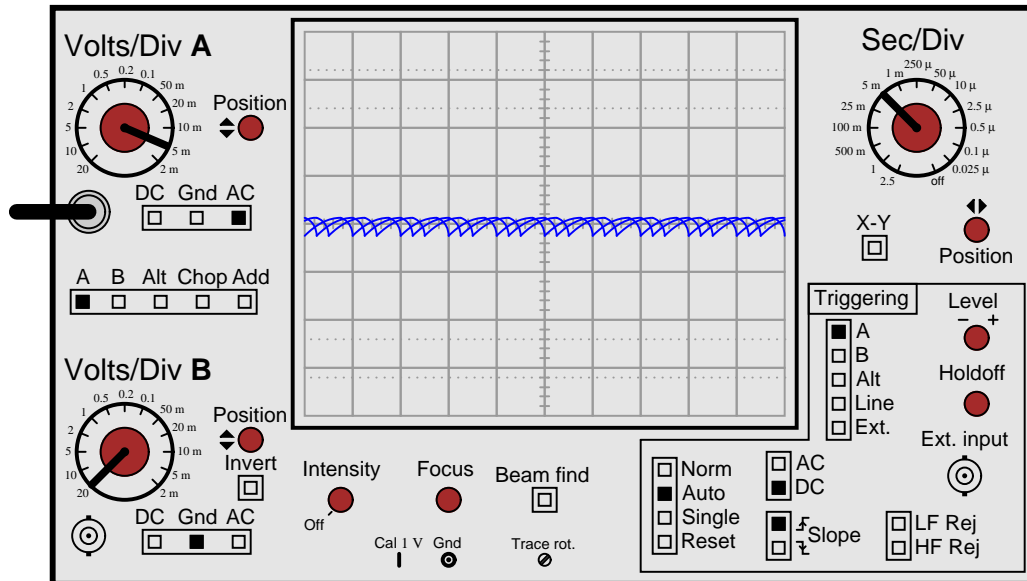

Explain what setting(s) the student can change on the oscilloscope to properly trigger this waveform so it will "hold still" on the screen.

[file 01911](#)

Question 57

All electric motors exhibit a large "inrush" current when initially started, due to the complete lack of counter-EMF when the rotor has not yet begun to turn. In some applications it is very important to know how large this transient current is. Shown here is a measurement setup for an oscilloscope to graph the inrush current to a DC motor:

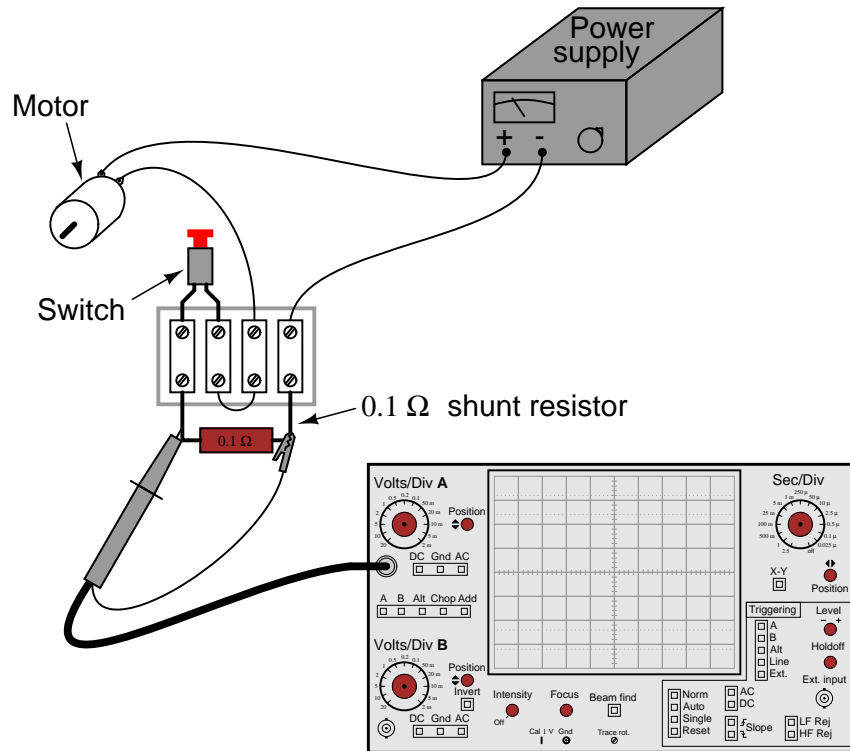

Explain how this circuit configuration enables the oscilloscope to measure motor current, when it plainly is a voltage-measuring instrument.

Also, explain how the oscilloscope may be set up to display only one "sweep" across the screen when the motor is started, and where the vertical and horizontal sensitivity knobs ought to be set to properly read the inrush current.

[file 01913](#)

---

Question 58

Suppose you were looking at this waveform in an oscilloscope display:

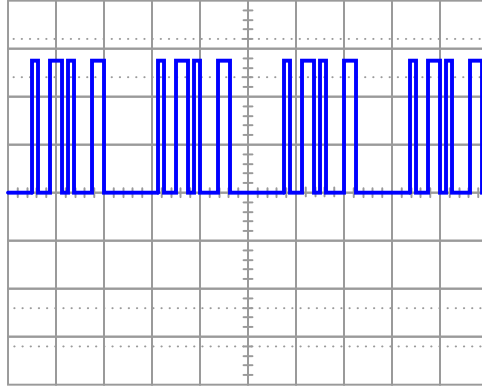

This is a difficult waveform to trigger, because there are so many identical leading and trailing edges to trigger from. No matter where the trigger level control is set, or whether it is set for rising- or falling-edge, the waveform will tend to "jitter" back and forth horizontally on the screen because these controls cannot discriminate the *first* pulse from the other pulses in each cluster of pulses. At the start of each "sweep," *any* of these pulses are adequate to initiate triggering.

One triggering control that is helpful in stabilizing such a waveform is the *trigger holdoff* control. Explain what this control does, and how it might work to make this waveform more stable on the screen.

[file 01914](#)

---

Question 59

A technician is measuring two waveforms of differing frequency at the same time on a dual-trace oscilloscope. The waveform measured by channel "A" seems to be triggered just fine, but the other waveform (channel "B") appears to be untriggered: the waveshape slowly scrolls horizontally across the screen as though the trace were free-running.

This presents a problem for the technician, because channel B's waveform is the more important one to have "locked" in place for viewing. What should the technician do to make channel B's display stable?

[file 01917](#)



Question 60

Another challenging sort of waveform to "lock in" on an oscilloscope display is one where a high-frequency waveform is superimposed on a low-frequency waveform. If the two frequencies are not integer multiples (harmonics) of each other, it will be impossible to make *both* of them hold still on the oscilloscope display.

However, most oscilloscopes have frequency-specific *rejection* controls provided in the trigger circuitry to help the user discriminate between mixed frequencies. Identify these controls on the oscilloscope panel, and explain which would be used for what circumstances.

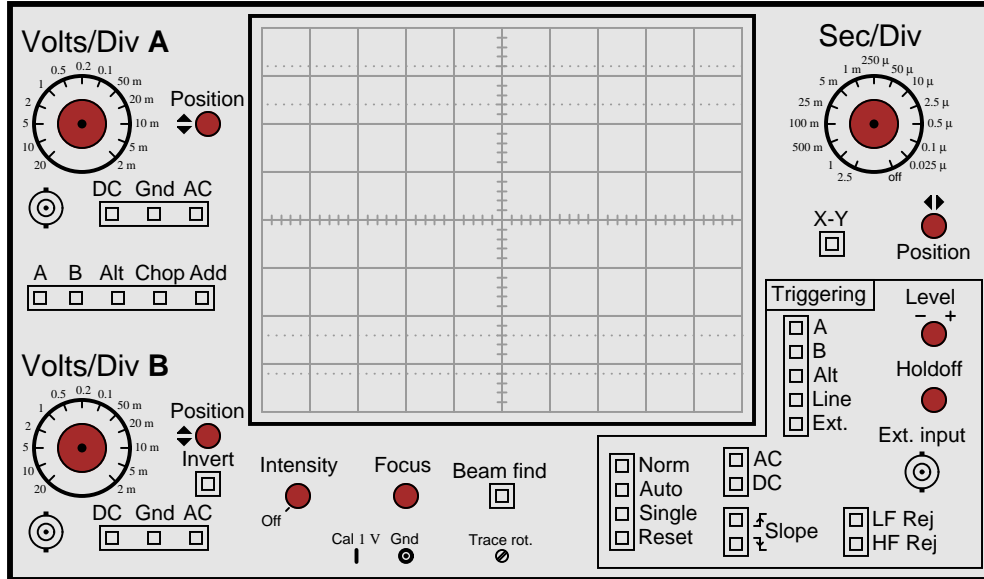

file 01916

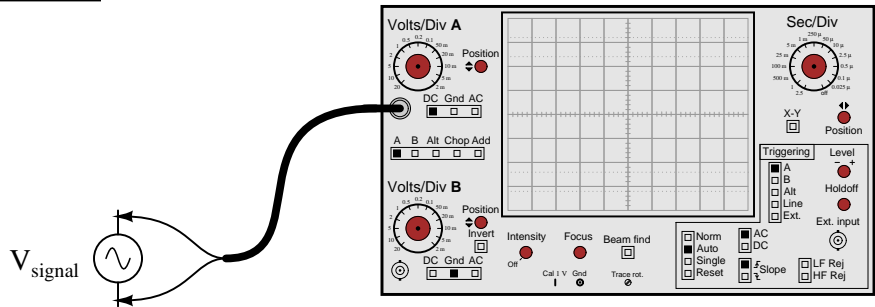
Competency: <b>Digital oscilloscope set-up</b>	Version:
<b>Schematic</b>	
	
<b>Given conditions</b>	
<p><math>V_{\text{signal}} =</math> Set by instructor without student's knowledge</p> <p><math>f_{\text{signal}} =</math> Set by instructor without student's knowledge</p>	
<b>Parameters</b>	
<p>Between two and five cycles of waveform displayed, without exceeding either top or bottom edge of screen.</p>	

file 03305

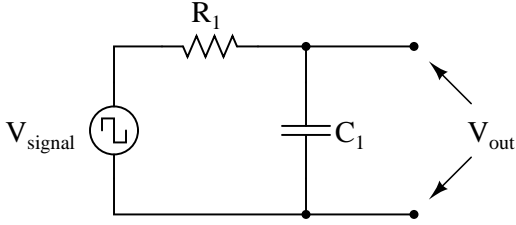
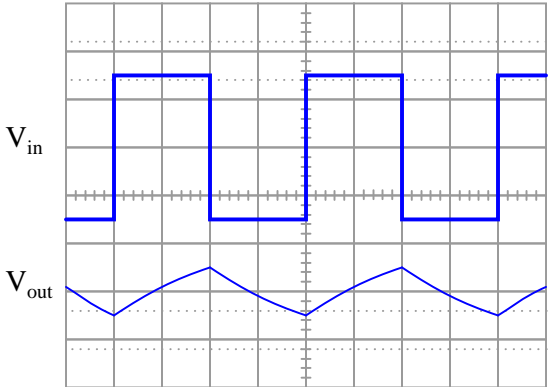
Competency: <b>Passive integrator circuit</b>		Version:
<b>Schematic</b>		
		
<b>Given conditions</b>		<b>Required waveshapes</b>
$f_{\text{signal}} =$		
<b>Parameters</b>		
<p style="text-align: center;">Predicted</p> <p><math>C_1</math> <input style="width: 80px; height: 20px;" type="text"/></p> <p><math>R_1</math> <input style="width: 80px; height: 20px;" type="text"/></p>		
<b>Fault analysis</b>		
<p>Suppose component <input style="width: 40px; height: 20px;" type="text"/> fails <input type="checkbox"/> open <input type="checkbox"/> other _____</p> <p style="margin-left: 100px;"><input type="checkbox"/> shorted</p> <p><i>What will happen in the circuit?</i></p>		

file 01687

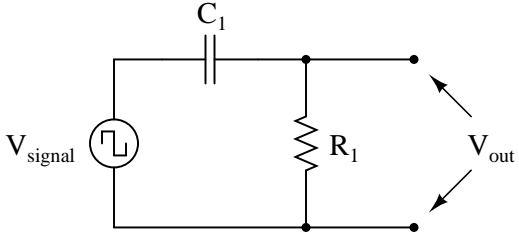
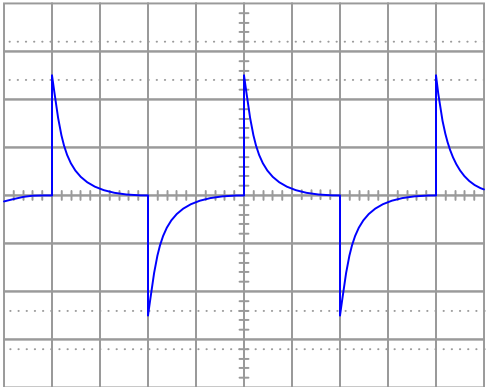
Competency: <b>Passive differentiator circuit</b>		Version:
<b>Schematic</b>		
		
<b>Given conditions</b>		<b>Required <math>V_{out}</math> waveshape</b>
$f_{signal} =$		
<b>Parameters</b>		
<p style="text-align: center;">Predicted</p> <p><math>C_1</math> <input style="width: 80px; height: 25px;" type="text"/></p> <p><math>R_1</math> <input style="width: 80px; height: 25px;" type="text"/></p>		
<b>Fault analysis</b>		
<p>Suppose component <input style="width: 40px; height: 20px;" type="text"/> fails <input type="checkbox"/> open <input type="checkbox"/> other _____</p> <p style="margin-left: 100px;"><input type="checkbox"/> shorted</p> <p><i>What will happen in the circuit?</i></p>		

file 01686

---

Question 64

NAME: \_\_\_\_\_

**Project Grading Criteria**

PROJECT: \_\_\_\_\_

You will receive the highest score for which *all* criteria are met.

100 % (*Must meet or exceed all criteria listed*)

- A. Impeccable craftsmanship, comparable to that of a professional assembly
- B. No spelling or grammatical errors anywhere in *any* document, upon first submission to instructor

95 % (*Must meet or exceed these criteria in addition to all criteria for 90% and below*)

- A. Technical explanation sufficiently detailed to teach from, inclusive of every component (supersedes 75.B)
- B. Itemized parts list complete with part numbers, manufacturers, and (equivalent) prices for *all* components, including recycled components and parts kit components (supersedes 90.A)

90 % (*Must meet or exceed these criteria in addition to all criteria for 85% and below*)

- A. Itemized parts list complete with prices of components purchased for the project, plus total price
- B. No spelling or grammatical errors anywhere in *any* document upon final submission

85 % (*Must meet or exceed these criteria in addition to all criteria for 80% and below*)

- A. “User’s guide” to project function (in addition to 75.B)
- B. Troubleshooting log describing all obstacles overcome during development and construction

80 % (*Must meet or exceed these criteria in addition to all criteria for 75% and below*)

- A. All controls (switches, knobs, etc.) clearly and neatly labeled
- B. All documentation created on computer, not hand-written (including the schematic diagram)

75 % (*Must meet or exceed these criteria in addition to all criteria for 70% and below*)

- A. Stranded wire used wherever wires are subject to vibration or bending
- B. Basic technical explanation of all major circuit sections
- C. Deadline met for working prototype of circuit (Date/Time = \_\_\_\_\_ / \_\_\_\_\_ )

70 % (*Must meet or exceed these criteria in addition to all criteria for 65%*)

- A. All wire connections sound (solder joints, wire-wrap, terminal strips, and lugs are all connected properly)
- B. No use of glue where a fastener would be more appropriate
- C. Deadline met for submission of fully-functional project (Date/Time = \_\_\_\_\_ / \_\_\_\_\_ ) – supersedes 75.C if final project submitted by that (earlier) deadline

65 % (*Must meet or exceed these criteria in addition to all criteria for 60%*)

- A. Project fully functional
- B. All components securely fastened so nothing is “loose” inside the enclosure
- C. Schematic diagram of circuit

60 % (*Must meet or exceed these criteria in addition to being safe and legal*)

- A. Project minimally functional, with all components located inside an enclosure (if applicable)
- B. Passes final safety inspection (proper case grounding, line power fusing, power cords strain-relieved)

0 % (*If any of the following conditions are true*)

- A. Fails final safety inspection (improper grounding, fusing, and/or power cord strain relieving)
- B. Intended project function poses a safety hazard
- C. Project function violates any law, ordinance, or school policy

file 03173

---

Question 65

What is a *harmonic* frequency? If an oscillator circuit outputs a fundamental frequency of 12 kHz, calculate the frequencies of the following harmonics:

- 1st harmonic =
- 2nd harmonic =
- 3rd harmonic =
- 4th harmonic =
- 5th harmonic =
- 6th harmonic =

[file 02255](#)

---

Question 66

The Fourier series for a square wave is as follows:

$$v_{square} = \frac{4}{\pi} V_m \left( \sin \omega t + \frac{1}{3} \sin 3\omega t + \frac{1}{5} \sin 5\omega t + \frac{1}{7} \sin 7\omega t + \dots + \frac{1}{n} \sin n\omega t \right)$$

Where,

$V_m$  = Peak amplitude of square wave

$\omega$  = Angular velocity of square wave (equal to  $2\pi f$ , where  $f$  is the fundamental frequency)

$n$  = An odd integer

Electrically, we might represent a square-wave voltage source as a circle with a square-wave symbol inside, like this:

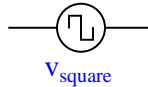

Knowing the Fourier series of this voltage, however, allows us to represent the same voltage source as a set of series-connected voltage sources, each with its own (sinusoidal) frequency. Draw the equivalent schematic for a 10 volt (peak), 200 Hz square-wave source in this manner showing only the first four harmonics, labeling each sinusoidal voltage source with its own RMS voltage value and frequency:

Hint:  $\omega = 2\pi f$

[file 02260](#)

---

Question 67

Suppose a non-sinusoidal voltage source is represented by the following Fourier series:

$$v(t) = 23.2 + 30 \sin(377t) + 15.5 \sin(1131t + 90) + 2.7 \sin(1508t - 40)$$

Electrically, we might represent this non-sinusoidal voltage source as a circle, like this:

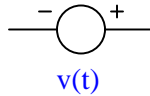

Knowing the Fourier series of this voltage, however, allows us to represent the same voltage source as a set of series-connected voltage sources, each with its own (sinusoidal) frequency. Draw the equivalent schematic in this manner, labeling each voltage source with its RMS voltage value, frequency (in Hz), and phase angle:

Hint:  $\omega = 2\pi f$

[file 02259](#)

---

Question 68

The *Fourier series* is much more than a mathematical abstraction. The mathematical equivalence between any periodic waveform and a series of sinusoidal waveforms can be a powerful analytical tool for the electronic engineer and technician alike.

Explain how knowing the Fourier series for a particular non-sinusoidal waveform simplifies the analysis of an AC circuit. For example, how would our knowledge of a square wave's Fourier series help in the analysis of this circuit?

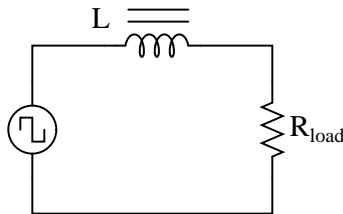

[file 02256](#)

---

Question 69

Identify some ways in which harmonics may be mitigated in AC power systems, since they tend to cause trouble for a variety of electrical components.

[file 02261](#)

---

Question 70

By visual inspection, determine which of the following waveforms contain even-numbered harmonics:

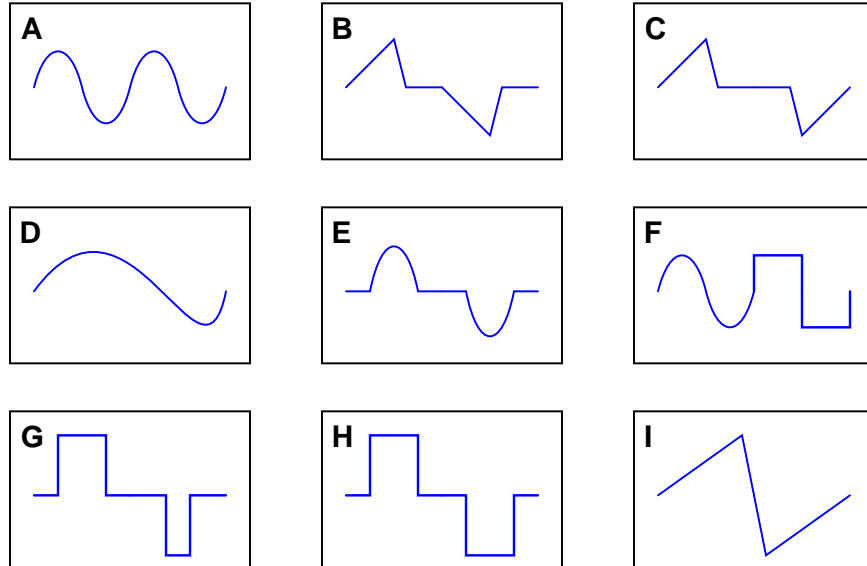

Note that only one cycle is shown for each waveform. Remember that we're dealing with continuous waveforms, endlessly repeating, and not single cycles as you see here.

[file 03306](#)

---

Question 71

Radio communication functions on the general principle of high-frequency AC power being *modulated* by low-frequency data. Two common forms of modulation are *Amplitude Modulation* (AM) and *Frequency Modulation* (FM). In both cases, the modulation of a high frequency waveform by a lower-frequency waveform produces something called *sidebands*.

Describe what "sidebands" are, to the best of your ability.

[file 00654](#)

---

Question 72

The storage of electric charge in a capacitor is often likened to the storage of water in a vessel:

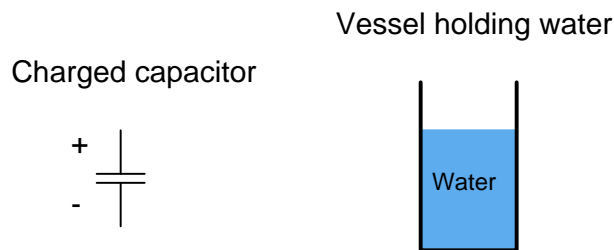

Complete this analogy, relating the electrical quantities of charge ( $Q$ ), voltage ( $E$  or  $V$ ), and capacitance ( $C$ ) to the quantities of water height, water volume, and vessel dimensions.

[file 00188](#)



---

Question 73

Complete this statement by substituting the correct electrical variables (voltage, current, resistance, inductance):

Inductors oppose changes in (*fill-in-the-blank*), reacting to such changes by producing a (*fill-in-the-blank*).

[file 00208](#)

---

Question 74

Complete this statement by substituting the correct electrical variables (voltage, current, resistance, capacitance):

Capacitors oppose changes in (*fill-in-the-blank*), reacting to such changes by producing a (*fill-in-the-blank*).

[file 00207](#)

---

Question 75

Electrical inductance has a close mechanical analogy: *inertia*. Explain what mechanical "inertia" is, and how the quantities of velocity and force applied to an object with mass are respectively analogous to current and voltage applied to an inductance.

[file 01138](#)

---

Question 76

Electrical capacitance has a close mechanical analogy: *elasticity*. Explain what the term "elasticity" means for a mechanical spring, and how the quantities of velocity and force applied to a spring are respectively analogous to current and voltage applied to a capacitance.

[file 01139](#)

---

Question 77

When a circuit designer needs a circuit to provide a time delay, he or she almost always chooses an RC circuit instead of an LR circuit. Explain why this is.

[file 01800](#)

---

Question 78

At a party, you happen to notice a mathematician taking notes while looking over the food table where several pizzas are set. Walking up to her, you ask what she is doing. "I'm mathematically modeling the consumption of pizza," she tells you. Before you have the chance to ask another question, she sets her notepad down on the table and excuses herself to go use the bathroom.

Looking at the notepad, you see the following equation:

$$\text{Percentage} = \left(1 - e^{-\frac{t}{5.8}}\right) \times 100\%$$

Where,

$t$  = Time in minutes since arrival of pizza.

The problem is, you don't know whether the equation she wrote describes the percentage of pizza eaten or the percentage of pizza remaining on the table. Explain how you would determine which percentage this equation describes. How, exactly, can you tell if this equation describes the amount of pizza already eaten or the amount of pizza that remains to be eaten?

[file 03309](#)

---

---

Question 79

Suppose a fellow electronics technician approaches you with a design problem. He needs a simple circuit that outputs brief pulses of voltage every time a switch is actuated, so that a computer receives a single pulse signal every time the switch is actuated, rather than a continuous "on" signal for as long as the switch is actuated:

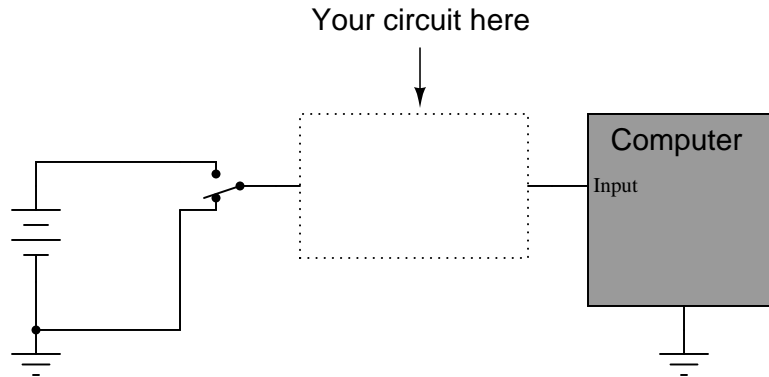

The technician suggests you build a *passive differentiator circuit* for his application. You have never heard of this circuit before, but you probably know where you can research to find out what it is! He tells you it is perfectly okay if the circuit generates negative voltage pulses when the switch is de-actuated: all he cares about is a single positive voltage pulse to the computer each time the switch actuates. Also, the pulse needs to be very short: no longer than 2 milliseconds in duration.

Given this information, draw a schematic diagram for a practical passive differentiator circuit within the dotted lines, complete with component values.

[file 01219](#)

---

Question 80

$\int f(x) dx$  Calculus alert!

Both the input and the output of this circuit are square waves, although the output waveform is slightly distorted and also has much less amplitude:

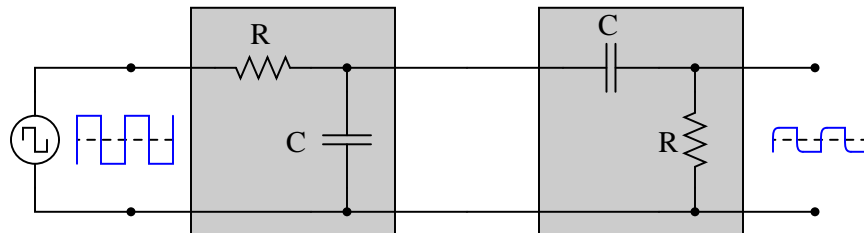

You recognize one of the RC networks as a passive integrator, and the other as a passive differentiator. What does the likeness of the output waveform compared to the input waveform indicate to you about differentiation and integration as *functions* applied to waveforms?

[file 01902](#)

---

Question 81

An LR differentiator circuit is used to convert a triangle wave into a square wave. One day after years of proper operation, the circuit fails. Instead of outputting a square wave, it outputs a triangle wave, just the same as the waveform measured at the circuit's input. Determine what the most likely component failure is in the circuit.

[file 01903](#)

---

Question 82

$\int f(x) dx$  *Calculus alert!*

If both these circuits are energized by an AC sine-wave source providing a perfectly undistorted signal, the resulting output waveforms will differ in phase and possibly in amplitude, but not in shape:

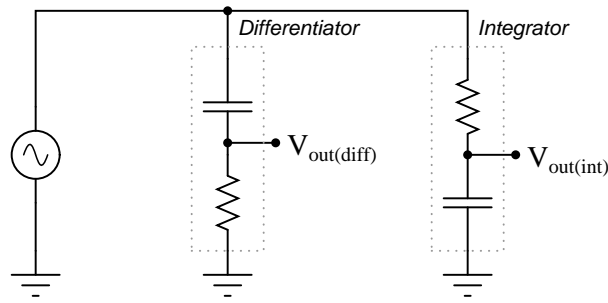

If, however, the excitation voltage is slightly distorted, one of the outputs will be more sinusoidal than the other. Explain whether it is the differentiator or the integrator that produces the signal most resembling a pure sine wave, and why.

Hint: I recommend building this circuit and powering it with a triangle wave, to simulate a mildly distorted sine wave.

[file 01600](#)

## Answers

---

### Answer 1

A *chord* is a mixture of three or more notes. On an oscilloscope, it would appear to be a very complex waveform, very non-sinusoidal.

Note: if you want to see this form yourself without going through the trouble of setting up a musical keyboard (or piano) and oscilloscope, you may simulate it using a graphing calculator or computer program. Simply graph the sum of three waveforms with the following frequencies:

- 261.63 Hz (middle "C")
- 329.63 Hz ("E")
- 392.00 Hz ("G")

---

### Answer 2

- 1st harmonic = 60 Hz
- 2nd harmonic = 120 Hz
- 3rd harmonic = 180 Hz
- 4th harmonic = 240 Hz
- 5th harmonic = 300 Hz
- 6th harmonic = 360 Hz

---

### Answer 3

- 1 octave greater than the fundamental = 2 kHz
- 2 octaves greater than the fundamental = 4 kHz
- 3 octaves greater than the fundamental = 8 kHz
- 4 octaves greater than the fundamental = 16 kHz
- 5 octaves greater than the fundamental = 32 kHz
- 6 octaves greater than the fundamental = 64 kHz

---

### Answer 4

Though it may seem strange to speak of it in such terms, an AC circuit "views" a square wave as an infinite series of sinusoidal harmonics.

Follow-up question: explain how this equivalence between a square wave and a particular series of sine waves is a practical example of the *Superposition Theorem* at work.

---

### Answer 5

$$P_R = 400 \text{ watts}$$

---

### Answer 6

$$P_{R(1st)} = 1.541 \text{ watts}$$

$$P_{R(3rd)} = 1.485 \text{ watts}$$

$$P_{R(5th)} = 1.384 \text{ watts}$$

$$P_{R(7th)} = 1.255 \text{ watts}$$

$$P_{R(1+3+5+7)} = 5.665 \text{ watts}$$

---

Answer 7

“*Any periodic waveform*, no matter how complex, is equivalent to a series of sinusoidal waveforms added together at different amplitudes and different frequencies, plus a DC component.”

Follow-up question: what does this equation represent?

$$f(t) = A_0 + (A_1 \sin \omega t) + (B_1 \cos \omega t) + (A_2 \sin 2\omega t) + (B_2 \cos 2\omega t) + \dots$$

---

Answer 8

A *spectrum analyzer*.

Challenge questions: two similar instruments are the *wave analyzer* and the *Fourier analyzer*. Explain how both these instruments are similar in function to a spectrum analyzer, and also how both differ.

---

Answer 9

Nonlinear loads.

---

Answer 10

I'll answer this question with another question: is the "B-H" plot for a ferromagnetic material typically linear or nonlinear? This is the key to understanding how an electromagnetic device can produce harmonics from a "pure" sinusoidal power source.

---

Answer 11

The addition of an even harmonic introduces asymmetry about the horizontal axis. The addition of odd harmonics does not.

Challenge question: explain *why* this is the case, any way you can.

---

Answer 12

Nonlinear loads are usually (but not always!) symmetrical in their distortion.

---

Answer 13

The following waveforms contain even-numbered harmonics: **B**, **C**, **D**, **F**, and **I**. The rest only contain odd harmonics of the fundamental.

---

Answer 14

The input signal is clean: a single peak at the 1 kHz mark. The amplifier's output, on the other hand, is a bit distorted (i.e. no longer a perfect sine-wave shape as the input is).

---

Answer 15

If the signal source is pure (no harmonics), the voltmeter will register nothing (negative infinite decibels) when the switch is flipped to the "test" position.

**Voltage and current for a capacitor:**

$$i = C \frac{dv}{dt}$$

**Voltage and current for an inductor:**

$$v = L \frac{di}{dt}$$

**Electromagnetic induction:**

$$v = N \frac{d\phi}{dt}$$

I leave it to you to describe how the rate-of-change over time of one variable relates to the other variables in each of the scenarios described by these equations.

Follow-up question: why is the derivative quantity in the student's savings account example expressed as a negative number? What would a positive  $\frac{dS}{dt}$  represent in real life?

Challenge question: describe actual circuits you could build to demonstrate each of these equations, so that others could see what it means for one variable's rate-of-change over time to affect another variable.

The graphical interpretation of "derivative" means the *slope* of the function at any given point.

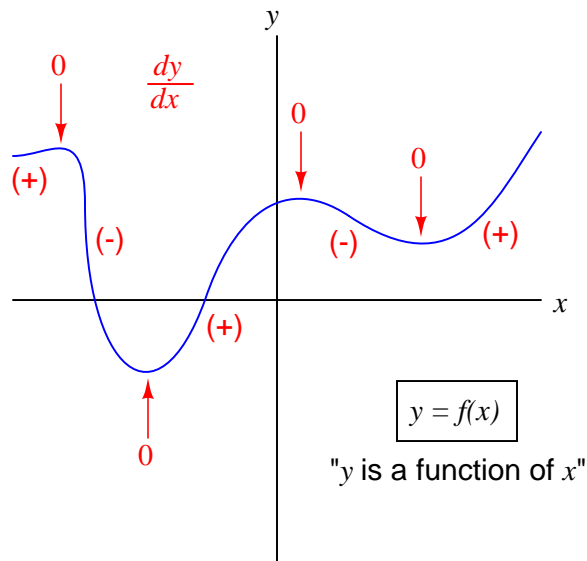

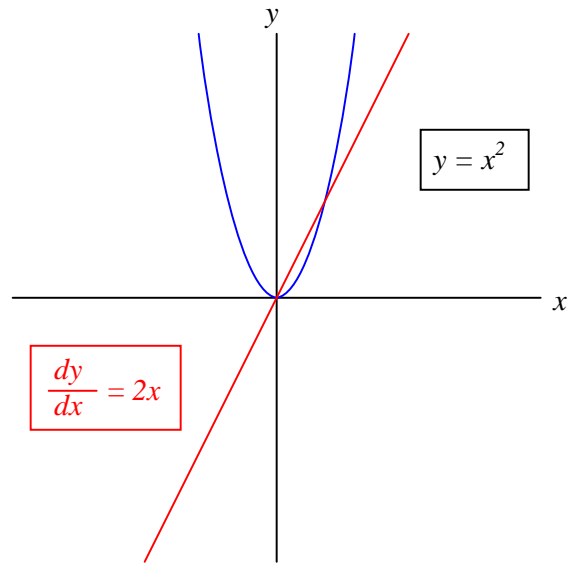

Challenge question: derivatives of power functions are easy to determine if you know the procedure. In this case, the derivative of the function  $y = x^2$  is  $\frac{dy}{dx} = 2x$ . Examine the following functions and their derivatives to see if you can recognize the "rule" we follow:

- $y = x^3$      $\frac{dy}{dx} = 3x^2$
- $y = x^4$      $\frac{dy}{dx} = 4x^3$
- $y = 2x^4$      $\frac{dy}{dx} = 8x^3$
- $y = 10x^5$      $\frac{dy}{dx} = 50x^4$
- $y = 2x^3 + 5x^2 - 7x$      $\frac{dy}{dx} = 6x^2 + 10x - 7$
- $y = 5x^3 - 2x - 16$      $\frac{dy}{dx} = 15x^2 - 2$
- $y = 4x^7 - 6x^3 + 9x + 1$      $\frac{dy}{dx} = 28x^6 - 18x^2 + 9$

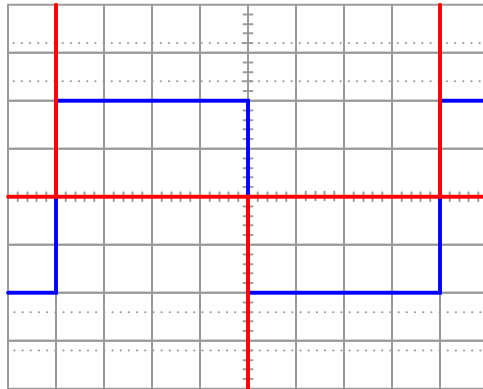
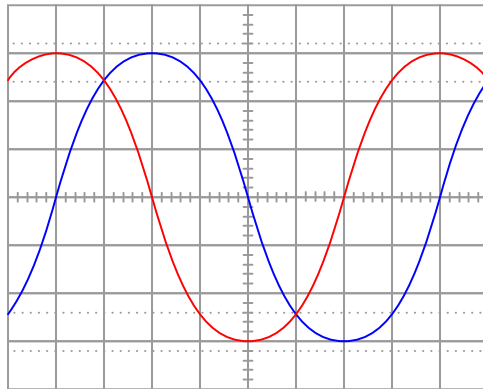
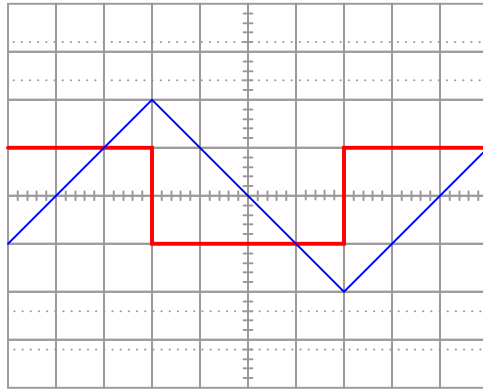

Follow-up question: what electronic device could perform the function of a "current-to-voltage converter" so we could use an oscilloscope to measure capacitor current? Be as specific as you can in your answer.



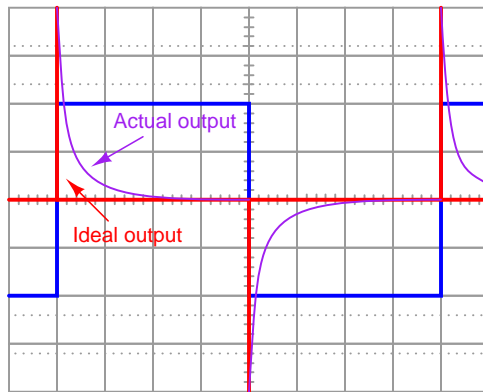
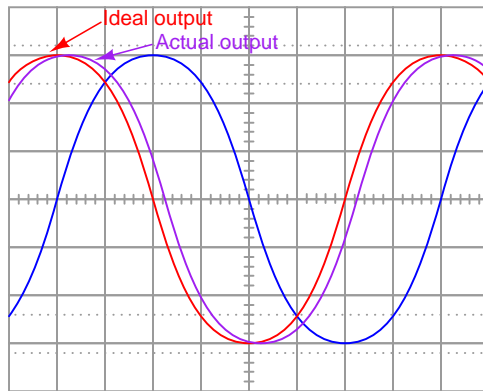
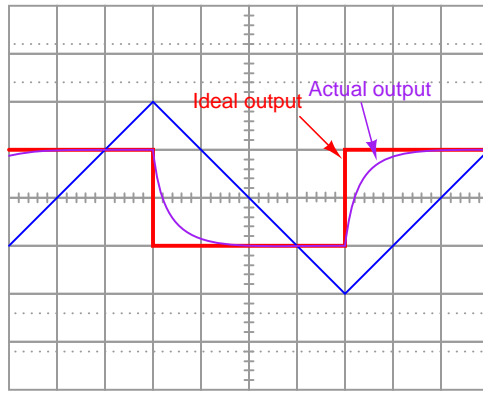

Follow-up question: given that  $R_{shunt} \ll X_C$  in order that the resistance does not impede the capacitor current to any significant extent, what does this suggest about the necessary time-constant ( $\tau$ ) of a passive differentiator circuit? In other words, what values of  $R$  and  $C$  would work best in such a circuit to produce an output waveform that is as close to ideal as possible?

---

Answer 21

Speed is the derivative of distance; distance is the integral of speed.

If the speed holds steady at some non-zero value, the distance will accumulate at a steady rate. If the distance holds steady, the speed indication will be zero because the car is at rest.

---

Answer 22

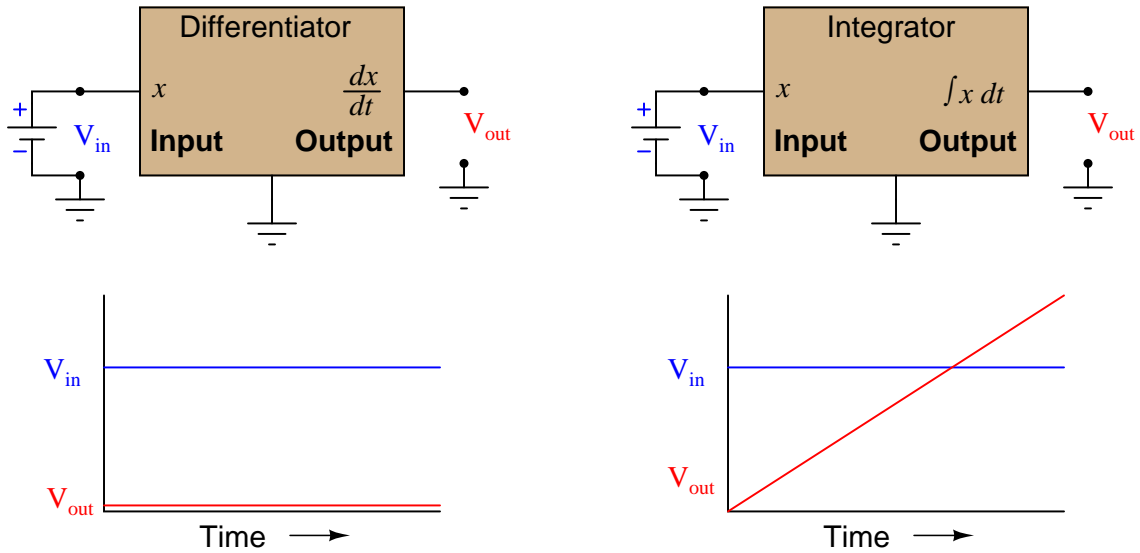

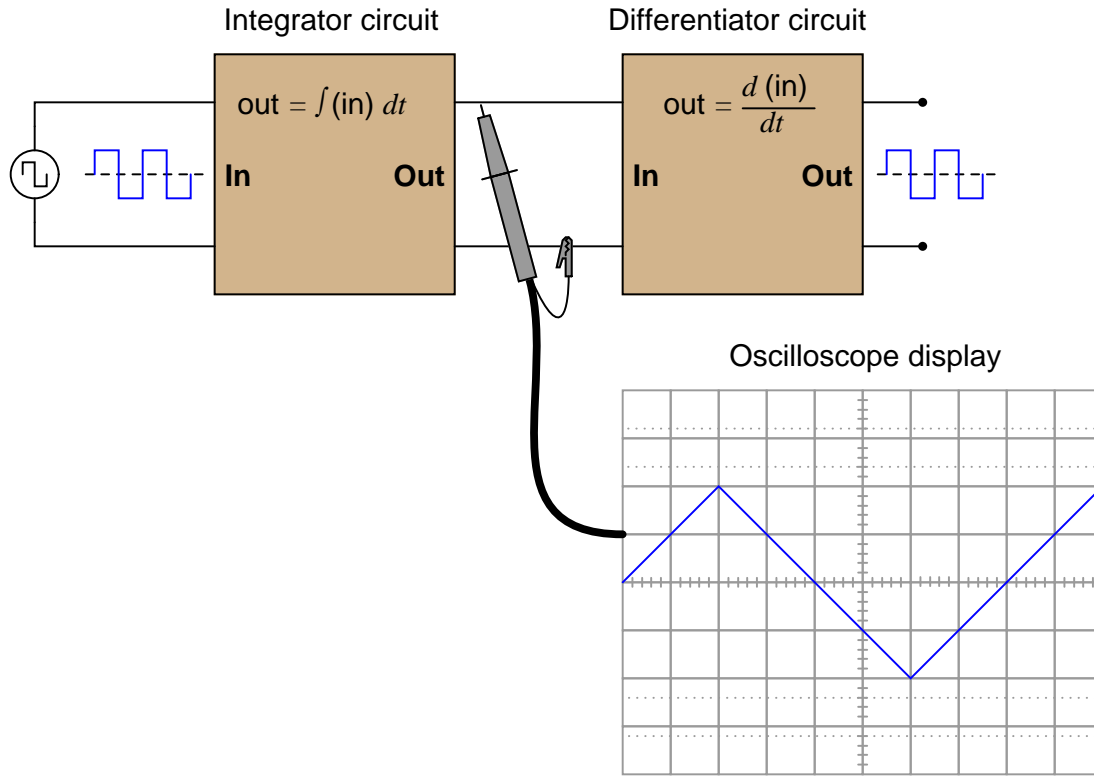

Follow-up question: what do the schematic diagrams of passive integrator and differentiator circuits look like? How are they similar to one another and how do they differ?

Answer 24

The graphical interpretation of "integral" means the *area* accumulated underneath the function for a given domain.

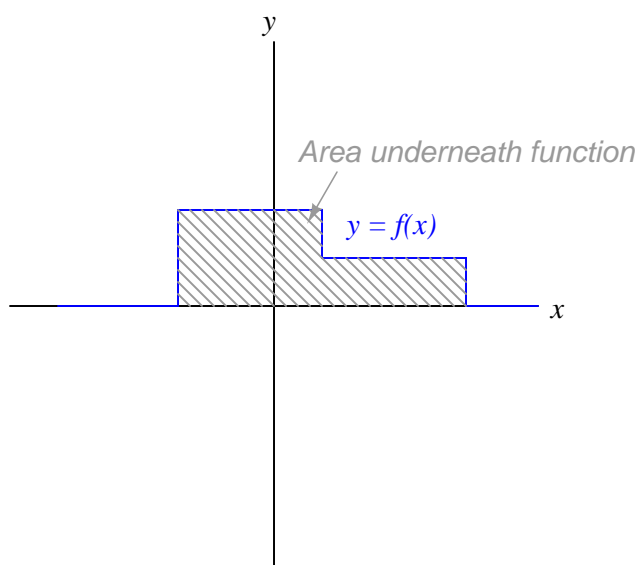
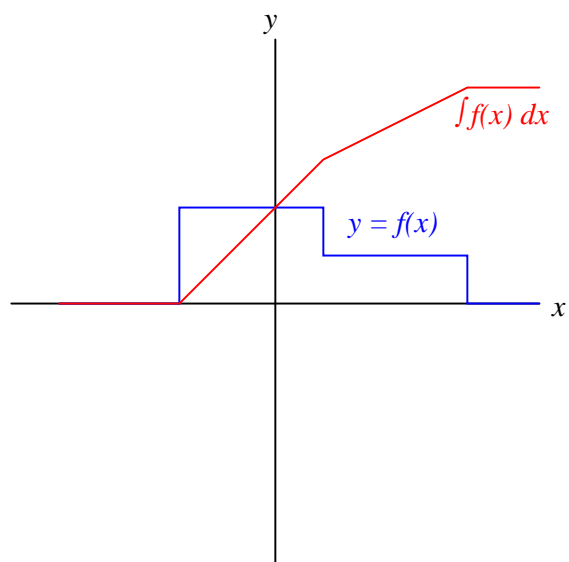

---

Answer 25

The differentiator's output signal would be proportional to the automobile's *acceleration*, while the integrator's output signal would be proportional to the automobile's *position*.

$$a \propto \frac{dv}{dt} \quad \text{Output of differentiator}$$

$$x \propto \int_0^T v dt \quad \text{Output of integrator}$$

Follow-up question: draw the schematic diagrams for these two circuits (differentiator and integrator).

---

Answer 26

The differentiator circuit's output signal represents the angular *velocity* of the robotic arm, according to the following equation:

$$v = \frac{dx}{dt}$$

Where,

$v$  = velocity

$x$  = position

$t$  = time

Follow-up question: what type of signal will we obtain if we differentiate the position signal twice (i.e. connect the output of the first differentiator circuit to the input of a second differentiator circuit)?

---

Answer 27

- Converting velocity signal to position signal: (**integrator**)
- Converting acceleration signal to velocity signal: (**integrator**)
- Converting position signal to velocity signal: (**differentiator**)
- Converting velocity signal to acceleration signal: (**differentiator**)
- Converting acceleration signal to position signal: (**two integrators!**)

I'll let you figure out the schematic diagrams on your own!

---

Answer 28

One possible solution is to use an electronic *integrator* circuit to derive a velocity measurement from the accelerometer's signal. However, this is not the only possible solution!

---

Answer 29

*Flow* ( $F$ ) is the variable we would have to measure, and that the integrator circuit would time-integrate into a height prediction.

---

Answer 30

The coil produces a voltage proportional to the conductor current's rate of change over time ( $v_{coil} = M \frac{di}{dt}$ ). The integrator circuit produces an output voltage changing at a rate proportional to the input voltage magnitude ( $\frac{dv_{out}}{dt} \propto v_{in}$ ). Substituting algebraically:

$$\frac{dv_{out}}{dt} = M \frac{di}{dt}$$

Review question: Rogowski coils are rated in terms of their *mutual inductance* ( $M$ ). Define what "mutual inductance" is, and why this is an appropriate parameter to specify for a Rogowski coil.

Follow-up question: the operation of a Rogowski coil (and the integrator circuit) is probably easiest to comprehend if one imagines the measured current starting at 0 amps and linearly increasing over time. Qualitatively explain what the coil's output would be in this scenario and then what the integrator's output would be.

Challenge question: the integrator circuit shown here is an "active" integrator rather than a "passive" integrator. That is, it contains an amplifier (an "active" device). We could use a passive integrator circuit instead to condition the output signal of the Rogowski coil, but only if the measured current is purely AC. A passive integrator circuit would be insufficient for the task if we tried to measure a DC current – only an active integrator would be adequate to measure DC. Explain why.

---

Answer 31

If you said, "five time constants' worth" ( $5\tau$ ), you might not be thinking deeply enough! In actuality, the voltage and current in such a circuit *never* finally reach stable values, because their approach is asymptotic.

However, after 5 time constants' worth of time, the variables in an RC or LR circuit will have settled to within 0.6% of their final values, which is good enough for most people to call "final."

---

Answer 32

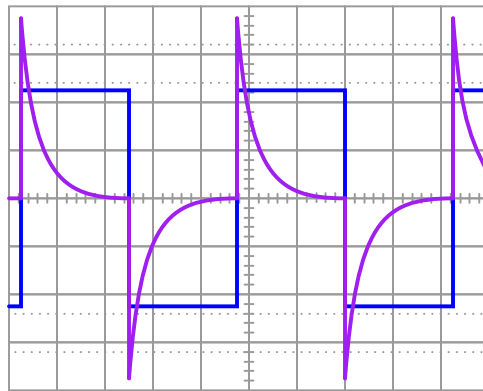

Follow-up question #1: what would we have to change in this passive differentiator circuit to make the output more closely resemble ideal differentiation?

Follow-up question #2: explain how it is possible that the differentiator's output waveform has a greater peak amplitude than the input (square) waveform.

---

Answer 33

Maximum values of  $R$  and  $C$  will best approximate a true triangle wave. The consequences of choosing extremely large values for  $R$  and/or  $C$  are not difficult to determine – I leave that for you to explain!

---

Answer 34

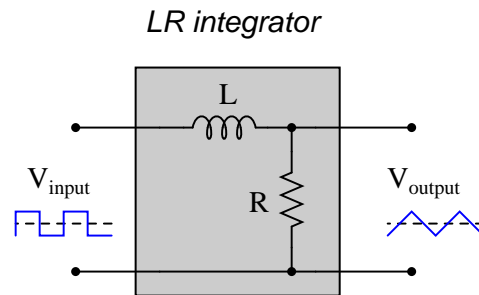

For maximum "triangle-like" waveshape, choose a large value for  $L$  and a small value for  $R$ .

Follow-up question: explain how the choices of values for  $L$  and  $R$  follow the same reasoning as the choices for  $R$  and  $C$  in an RC passive integrator circuit.

---

Answer 35

Passive integrators need to have *slow* time constants, while passive differentiators need to have *fast* time constants, in order to reasonably integrate and differentiate.

---

Answer 36

The answer to this question is so easy for you to research, it would be an insult to print it here!

---

Answer 37

These two integrators act as a second-order lowpass filter, attenuating the harmonics in the square wave far more than the fundamental.

Challenge question: does the output waveshape more closely resemble a sine wave when the source frequency is increased or decreased?

---

Answer 38

Here is a hint: set  $x$  to zero and evaluate each equation.

---

Answer 39

Time	$V_C$ (volts)
0 ms	0
30 ms	12.29
60 ms	19.71
90 ms	24.19
120 ms	26.89
150 ms	28.52

---

Answer 40

$V_{\text{out}} = 2.82$  volts @ 1 ms after rising edge

---

Answer 41

$$V_{out} = 1.172 \text{ volts @ } 150 \mu\text{s after rising edge}$$

---

Answer 42

$$t_{pulse} = 11.77 \mu\text{s}$$

---

Answer 43

Time	Switch motion	$V_C$ (volts)
0 s	discharge $\rightarrow$ charge	0 volts
5 s	charge $\rightarrow$ discharge	6.549 volts
10 s	discharge $\rightarrow$ charge	2.260 volts
15 s	charge $\rightarrow$ discharge	7.329 volts
20 s	discharge $\rightarrow$ charge	2.529 volts
25 s	charge $\rightarrow$ discharge	7.422 volts

---

Answer 44

Transition	$v_{out}$
#1 (0 $\rightarrow$ 5 volts)	0 volts
#2 (5 $\rightarrow$ 0 volts)	3.395 volts
#3 (0 $\rightarrow$ 5 volts)	1.090 volts
#4 (5 $\rightarrow$ 0 volts)	3.745 volts
#5 (0 $\rightarrow$ 5 volts)	1.202 volts
#6 (5 $\rightarrow$ 0 volts)	3.781 volts
#7 (0 $\rightarrow$ 5 volts)	1.214 volts
#8 (5 $\rightarrow$ 0 volts)	3.785 volts

Challenge question: what are the final (ultimate) values for the integrator output's sawtooth-wave peak voltages?

---

Answer 45

$$V_{out} \text{ (peak-to-peak)} = 8.025 \text{ volts}$$

Follow-up question: the components comprising this circuit are improperly sized if it is actually expected to function as a reasonably accurate *integrator*. Suggest better component values for the frequency of signal being integrated.

Challenge question: write a formula that solves for this peak-to-peak output voltage ( $V_{out}$ ) given the peak-to-peak input voltage ( $V_{in}$ ), resistor value  $R$ , capacitor value  $C$ , and signal frequency  $f$ .

---

Answer 46

The best "answer" I can give to this question is to get an analog oscilloscope and a signal generator and experiment to see how "free-run" mode works. If your oscilloscope does not have a "free-run" mode, you may emulate it by setting the *trigger* control to "EXTERNAL" (with no probe connected to the "EXTERNAL TRIGGER" input). You will have to adjust the sweep control very carefully to get any waveform "locked" in place on the display. Set the signal generator to a low frequency (10 Hz is good) so that the left-to-right sweeping of the dot is plainly visible, and use the "vernier" or "fine" timebase adjustment knob to vary the sweep rate as needed to get the waveform to stand still.



Answer 47

In this system, the fan would *always* appear to "stand still" in a position where a fan blade is near the sensor.

Follow-up question: how would the strobe light respond if the fan speed were changed? Explain your answer in detail.

Answer 48

The "trigger" circuitry on an oscilloscope initiates each left-to-right sweep of the electron beam only when certain conditions are met. Usually, these conditions are that the input signal being measured attains a specified voltage level (set by the technician), in a specified direction (either increasing or decreasing). Other conditions for triggering are possible, though.

Answer 49

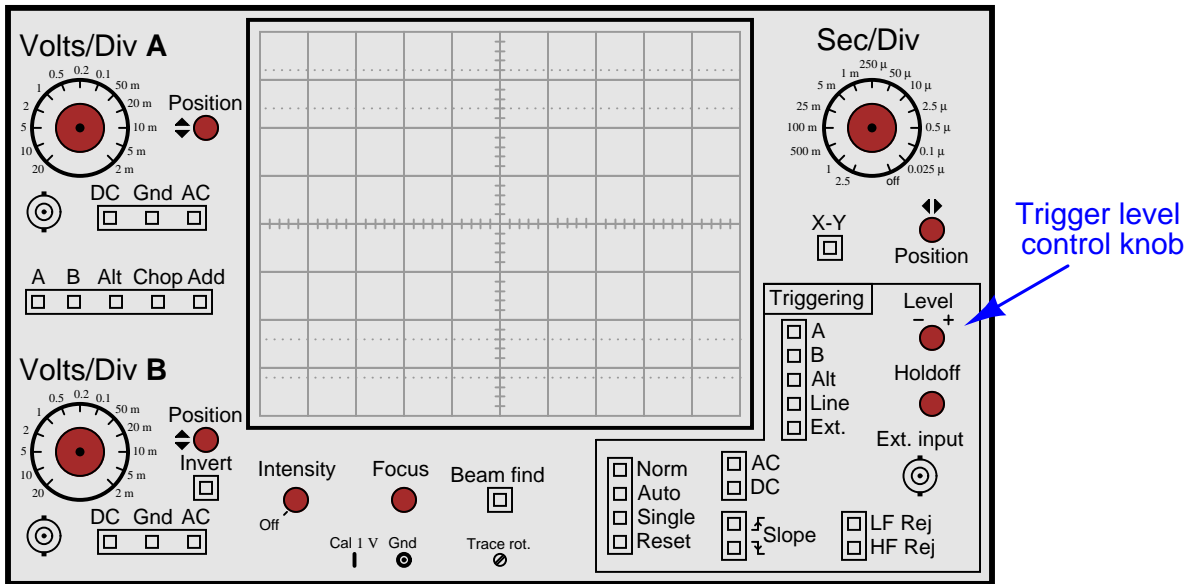

Answer 50

The waveform will shift to the left as the trigger level is raised:

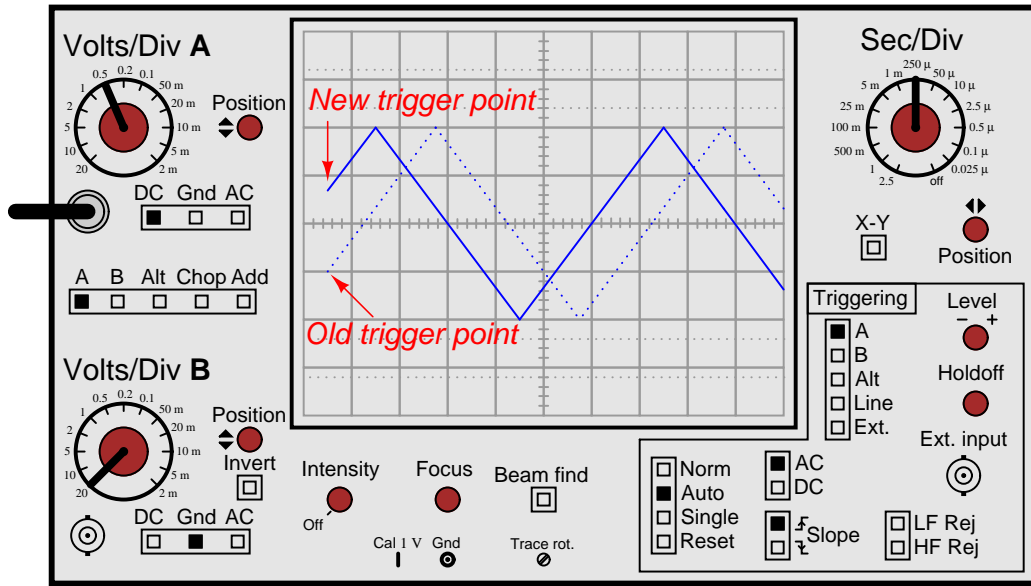

Answer 51

The waveform will begin at the same voltage level, only on the "down" side instead of on the "up" side:

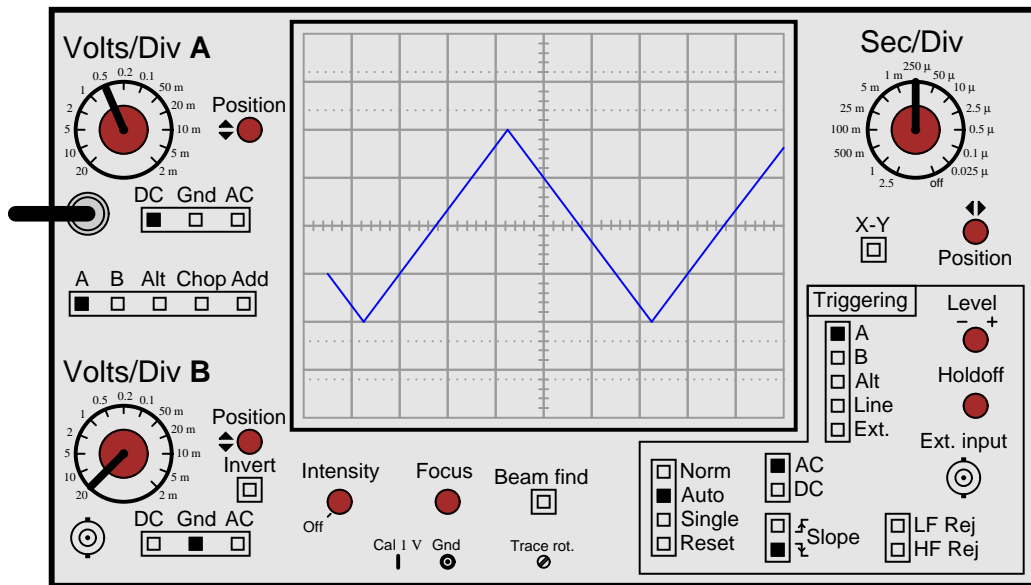

Answer 52

This student's oscilloscope is set on the *Norm* mode. If it were set on the *Auto* mode, the trace would default to "free-running" if ever the trigger level were set above or below the waveform's amplitude. Instead of completely disappearing, the waveform would scroll horizontally and not "stand still" if the trigger level were set too high or too low.

Answer 53

In this mode, the oscilloscope triggers off the power-line waveform.

Follow-up question: what circumstance can you think of that would require this triggering source?

Answer 54

Connect the "sync" pulse output to the "External Input" connector on the oscilloscope's front panel, and set the trigger source accordingly:

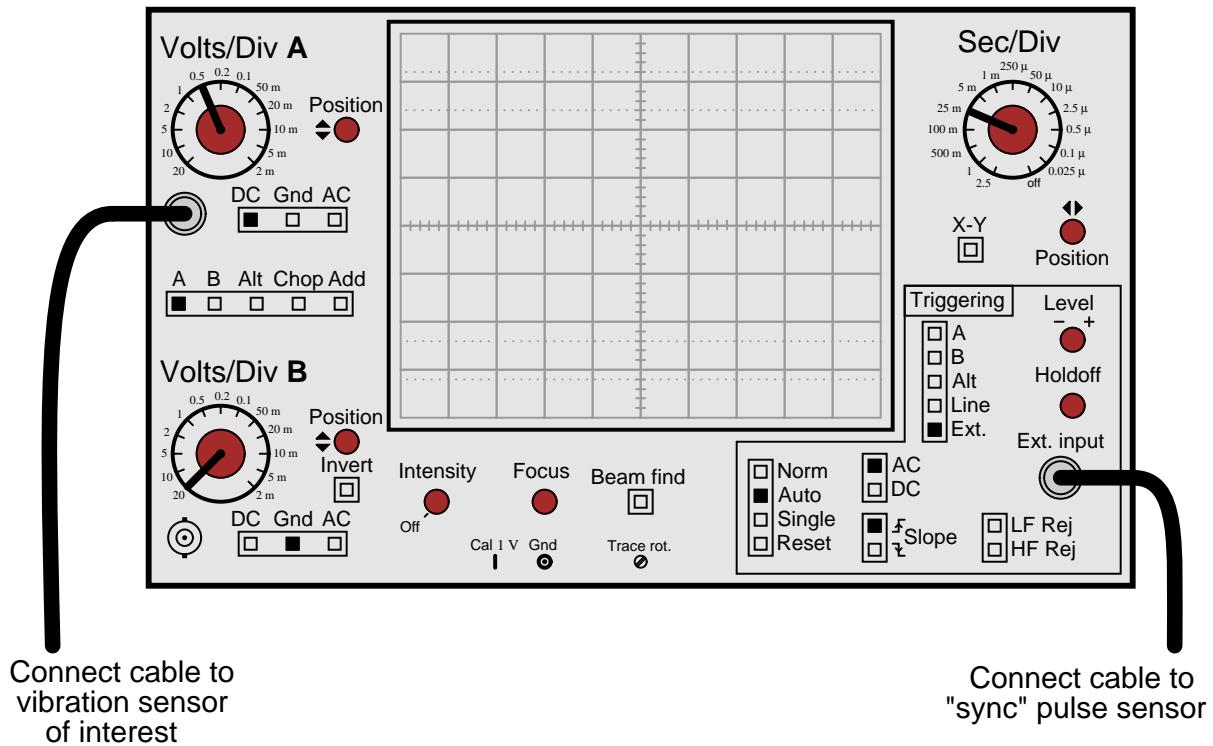

Answer 55

Set the trigger coupling control from "DC" to "AC".

Answer 56

Perhaps the easiest thing to do is set the trigger source to "Line" instead of "A", so that the oscilloscope has a larger signal to trigger from. However, this is not the only option the student has!

---

Answer 57

The shunt resistor performs the current-to-voltage conversion necessary for the oscilloscope to measure current.

In order to display only one "sweep," the oscilloscope triggering needs to be set to *single* mode. By the way, this works exceptionally well on digital-storage oscilloscopes, but not as well on analog oscilloscopes.

There are no "easy" answers for how to set the vertical and horizontal controls. Issues to consider (and discuss in class!) include:

- Expected inrush current (several times full-load current)
- Scaling factor provided by resistive shunt
- Typical ramp-up time for motor, in seconds

Challenge question: the larger the shunt resistor value, the stronger the signal received by the oscilloscope. The smaller the shunt resistor value, the weaker the signal received by the oscilloscope, making it difficult to accurately trigger on and measure the current's peak value. Based on this information, one might be inclined to choose the largest shunt resistor size available – but doing so will cause other problems. Explain what those other problems are.

---

Answer 58

The "holdoff" control sets an adjustable period of time after each trigger even where subsequent events are ignored.

---

Answer 59

Switch the trigger source control from "A" to "B".

Follow-up question: if the above advice is taken, channel B's waveform will become "locked" in place, but channel A's waveform will now begin to scroll across the screen. Is there any way to lock *both* waveforms in place so neither one appears to scroll across the screen?

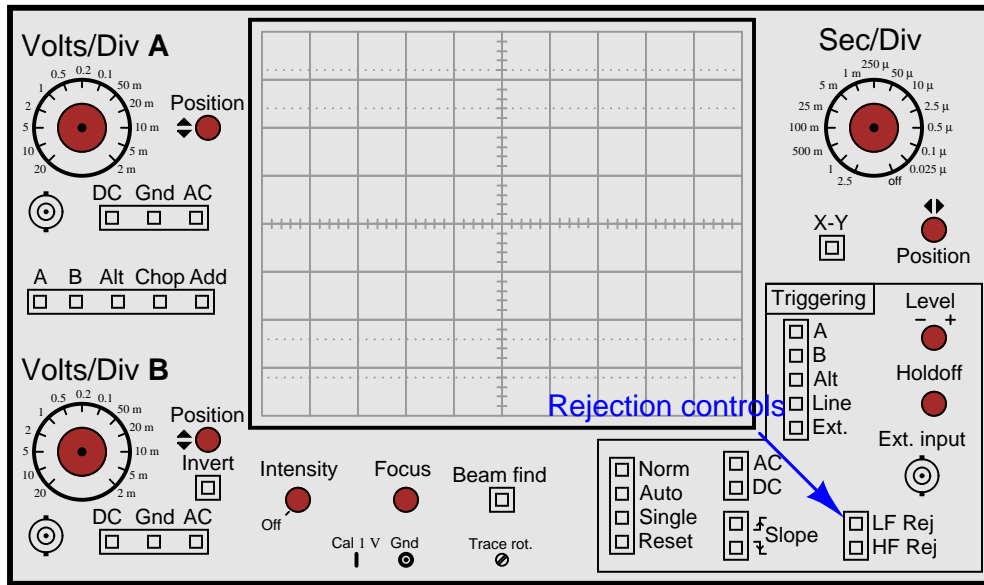

Follow-up question: identify the filter circuits internal to the oscilloscope associated with each of these "rejection" controls.

Answer 61

You may use circuit simulation software to set up similar oscilloscope display interpretation scenarios, for practice or for verification of what you see in this exercise.

Answer 62

Use circuit simulation software to verify your predicted and measured parameter values.

Answer 63

Use circuit simulation software to verify your predicted and measured parameter values.

Answer 64

Be sure you meet with your instructor if you have any questions about what is expected for your project!

Answer 65

- 1st harmonic = 12 kHz
- 2nd harmonic = 24 kHz
- 3rd harmonic = 36 kHz
- 4th harmonic = 48 kHz
- 5th harmonic = 60 kHz
- 6th harmonic = 72 kHz

---

Answer 66

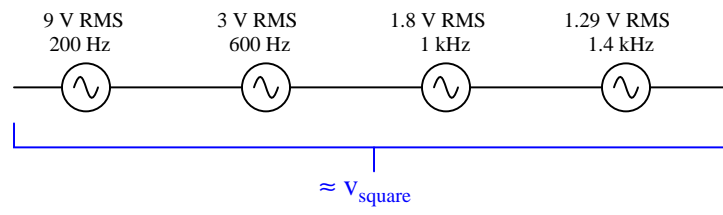

---

Answer 67

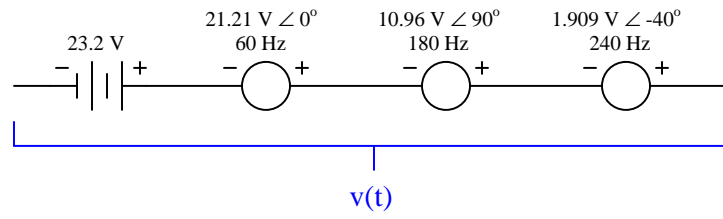

---

Answer 68

The circuit could be analyzed one harmonic at a time, the results combined via the *Superposition Theorem*:

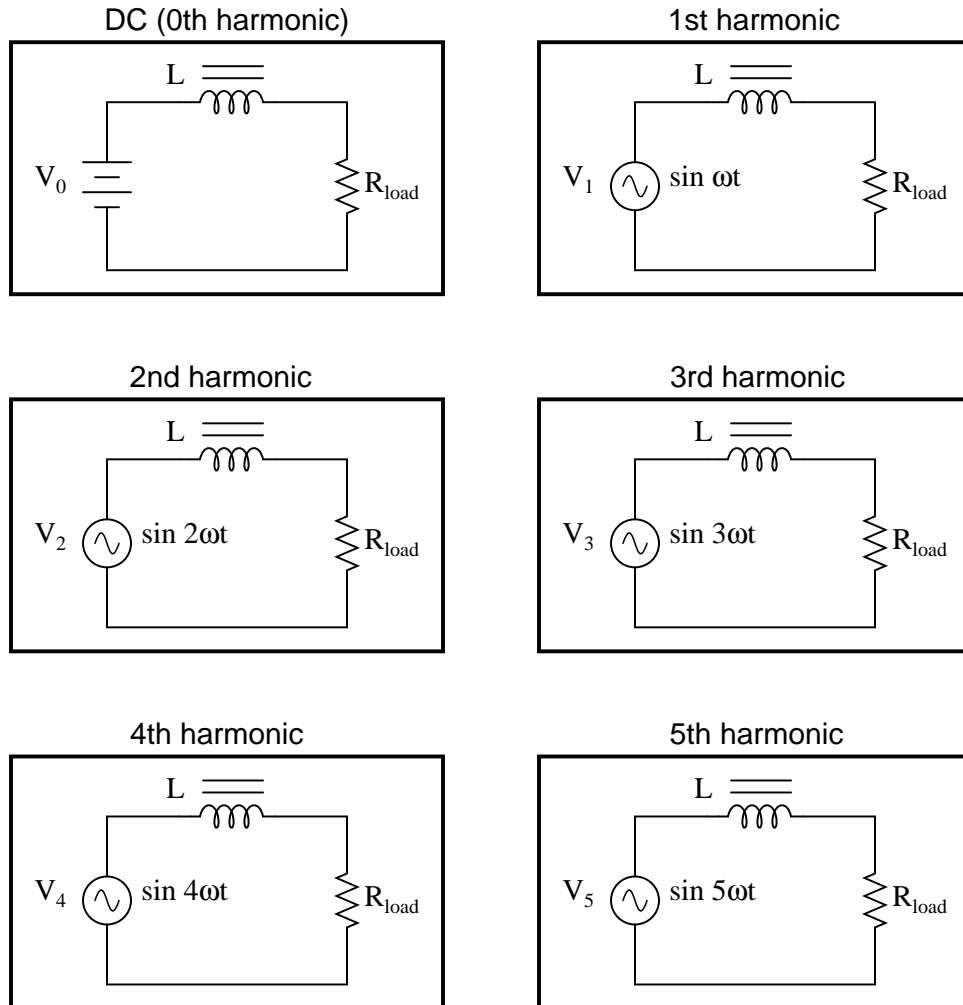

---

Answer 69

Filter circuits may be employed to block harmonic frequencies from reaching certain sensitive components.

---

Answer 70

The following waveforms contain even-numbered harmonics: **C**, **D**, **G**, and **I**. The rest only contain odd harmonics of the fundamental.

---

Answer 71

”Sidebands” are sinusoidal frequencies just above and just below the carrier frequency, produced as a result of the modulation process. On a spectrum analyzer, they show up as peaks to either side of the main (carrier) peak. Their quantity, frequencies, and amplitudes are all a function of the data signals modulating the carrier.

---

Answer 72

Electrical charge  $\equiv$  Water volume

Voltage  $\equiv$  Height of water column in vessel

Capacitance  $\equiv$  Area of vessel, measured on a cross-section with a horizontal plane

---

Answer 73

Inductors oppose changes in **current**, reacting to such changes by producing a **voltage**.

---

Answer 74

Capacitors oppose changes in **voltage**, reacting to such changes by producing a **current**.

---

Answer 75

As an object is subjected to a constant, unbalanced force, its velocity changes at a linear rate:

$$F = m \frac{dv}{dt}$$

Where,

$F$  = Net force applied to object

$m$  = Mass of object

$v$  = Velocity of object

$t$  = Time

In a similar manner, a pure inductance experiencing a constant voltage will exhibit a constant rate of current change over time:

$$e = L \frac{di}{dt}$$

---

Answer 76

As a spring is compressed at a constant velocity, the amount of reaction force it generates increases at a linear rate:

$$v = \frac{1}{k} \frac{dF}{dt}$$

Where,

$v$  = Velocity of spring compression

$k$  = Spring "stiffness" constant

$F$  = Reaction force generated by the spring's compression

$t$  = Time

In a similar manner, a pure capacitance experiencing a constant current will exhibit a constant rate of voltage change over time:

$$i = C \frac{de}{dt}$$

---

Answer 77

Capacitors are generally cheaper and easier to work with than inductors for making time delay circuits.



---

Answer 78

This equation models the percentage of pizza *eaten* at time  $t$ , not how much remains on the table.

---

Answer 79

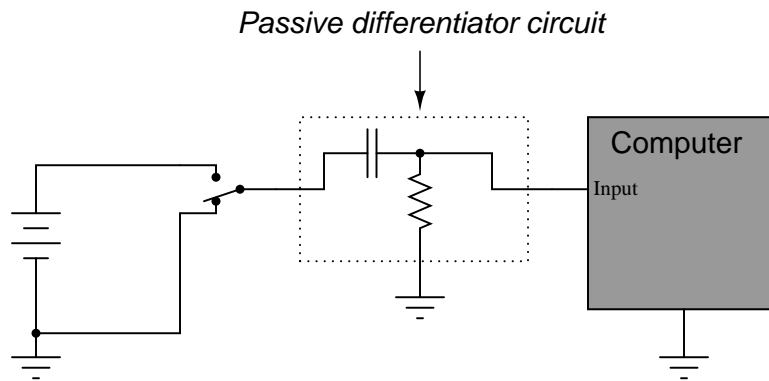

Did you really think I would give you the component values, too? I can't make it too easy for you!

Challenge question: An alternative design to the differentiator circuit shown above is this:

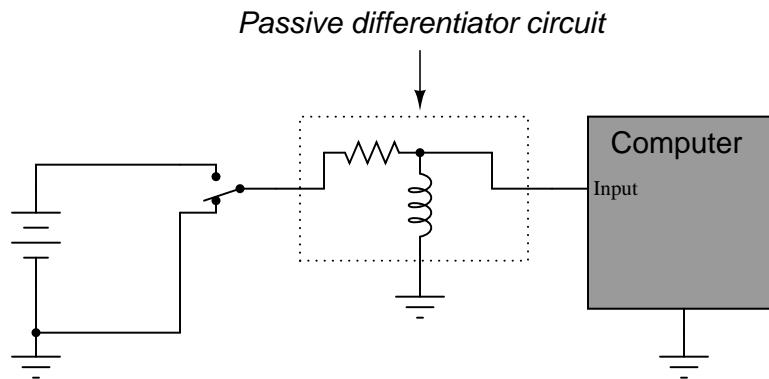

This circuit would certainly work to create brief pulses of voltage to the computer input, but it would also likely *destroy* the computer's input circuitry after a few switch actuations! Explain why.

---

Answer 80

Differentiation and integration are mathematically inverse functions of one another. With regard to waveshape, either function is reversible by subsequently applying the other function.

Follow-up question: this circuit will not work as shown if both  $R$  values are the same, and both  $C$  values are the same as well. Explain why, and also describe what value(s) would have to be different to allow the original square-waveshape to be recovered at the final output terminals.

---

Answer 81

The inductor is failed open.

Follow-up question: this is not the only possible failure, but it is the most likely. Explain what the other failure(s) could be, and also why the one given here is most likely.

The *differentiator* circuit will output a much more distorted waveshape, because differentiation magnifies harmonics:

$$\frac{d}{dt}(\sin t) = \cos t$$

$$\frac{d}{dt}(\sin 2t) = 2 \cos 2t$$

$$\frac{d}{dt}(\sin 3t) = 3 \cos 3t$$

$$\frac{d}{dt}(\sin 4t) = 4 \cos 4t$$

...

$$\frac{d}{dt}(\sin nt) = n \cos nt$$

Notes 1

Students with a musical background (especially piano) should be able to add substantially to the discussion on this question. The important concept to discuss here is that multiple frequencies of any signal form (AC voltage, current, sound waves, light waves, etc.) are able to exist simultaneously along the same signal path without interference.

---

Notes 2

Ask your students to determine the mathematical relationship between harmonic number, harmonic frequency, and fundamental frequency. It isn't difficult to figure out!

---

Notes 3

Ask your students if they can determine the mathematical relationship between octave number, octave frequency, and fundamental frequency. This is a bit more difficult to do than for integer harmonics, but not beyond reason if students are familiar with exponents.

Clarify for your students the fact that "octave" is not just a musical term. In electronic circuit analysis (especially filter circuits), the word "octave" is often used to represent multiples of a given frequency, usually in reference to a bandwidth (i.e. "This filter's passband response is essentially flat over two octaves!").

---

Notes 4

If you have access to a graphing calculator or a computer with graphing software installed, and a projector capable of showing the resulting graph(s), you may demonstrate this square-wave synthesis in front of the whole class. It makes an excellent illustration of the concept.

Discuss this with your students: that the relatively simple rules of AC circuit analysis (calculating reactance by  $\omega L$  and  $\frac{1}{\omega C}$ , calculating impedance by the trigonometric sum of reactance and resistance, etc.) can be applied to the analysis of a square wave's effects if we repeat that analysis for every harmonic component of the wave.

This is truly a remarkable principle, that the effects of a complex waveform on a circuit may be determined by considering each of that waveform's harmonics separately, then those effects added together (superimposed) just as the harmonics themselves are superimposed to form the complex wave. Explain to your students how this superposition principle is not limited to the analysis of square waves, either. *Any* complex waveform whose harmonic constituents are known may be analyzed in this fashion.

---

Notes 5

To calculate this power figure, students have to determine the RMS value of the square wave. Thankfully, this is not difficult.

---

Notes 6

To calculate this power figure, students have to research the Fourier series for a square wave. Many textbooks use square waves to introduce the subject of Fourier series, so this should not be difficult for students to find.

Ask your students how the real power dissipated by this resistor compares with the final figure of 5.665 watts. Is the real power dissipation more, less, or equal to this figure? If not equal, what would we have to do to arrive at a more precise figure?

---

Notes 7

So far, all the "tools" students have learned about reactance, impedance, Ohm's Law, and such in AC circuits assume sinusoidal waveforms. Being able to equate any non-sinusoidal waveform to a series of sinusoidal waveforms allows us to apply these "sinusoidal-only" tools to *any* waveform, theoretically.

An important caveat of Fourier's theorem is that the waveform in question must be *periodic*. That is, it must repeat itself on some fixed period of time. Non-repetitive waveforms do not reduce to a definite series of sinusoidal terms. Fortunately for us, a great many waveforms encountered in electronic circuits are periodic and therefore may be represented by, and analyzed in terms of, definite Fourier series.

It would be good to mention the so-called *FFT* algorithm in this discussion while you're on this topic: the digital algorithm that computers use to separate any sampled waveform into multiple constituent sinusoidal frequencies. Modern computer hardware is able to easily implement the FFT algorithm, and it finds extensive use in analytical and test equipment.

---

Notes 8

Spectrum analyzers capable of analyzing radio-frequency signals are very expensive, but low-cost personal computer hardware and software does a good job of analyzing complex audio signals. It would be a benefit to your class to have a low-frequency spectrum analyzer setup available for student use, and possible demonstration during discussion.

---

Notes 9

My answer to this question is intentionally vague. It is correct, but does not reveal anything about the real nature of the cause, or more importantly, *why* a "nonlinear" load would cause harmonics. Discuss with your students what a "nonlinear" device is, and what it does to a sinusoidal signal to generate harmonics.

---

Notes 10

Ask your students what it means for an electrical or electronic device to be "linear." How many devices qualify as linear? And of those devices, are they *always* linear, or are they capable of nonlinear behavior under special conditions?

Use the discussion time to review B-H curves for ferromagnetic materials with your students, asking them to draw the curves and point out where along those curves inductors and transformers normally operate. What conditions, specifically, would make an iron-core device act nonlinearly?

On a similar note, the (slightly) nonlinear nature of ferromagnetic core transformers is known to permit signals to *modulate* each other in certain audio amplifier designs, to produce a specific kind of audio signal distortion known as *intermodulation distortion*. Normally, modulation is a function possible only in nonlinear systems, so the fact that modulation occurs in a transformer is proof positive of (at least some degree of) nonlinearity.

Although the sequence of images presented in the question by no means constitutes a formal proof, it should lead students to observe a trend: that odd harmonics do not make a waveform unsymmetrical about the horizontal axis, whereas even harmonics do. Given these two facts, we may make qualitative judgments about the harmonic content of a waveform simply by visually checking for symmetry about the horizontal axis.

Incidentally, some students have a difficult time grasping the concept of symmetry about the horizontal axis of a waveform. Take this simple example, which *is* symmetrical about its horizontal centerline:

*(Flipping waveform about the axis)*

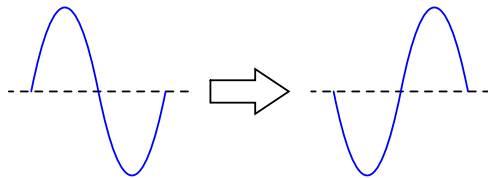

Some students will protest that this waveform is *not* symmetrical about its centerline, because it does not look exactly the same as before after flipping. They must bear in mind, though, that this is just one cycle of a continuous waveform. In reality, the waveform looks like this before and after flipping:

*(Flipping waveform about the axis)*

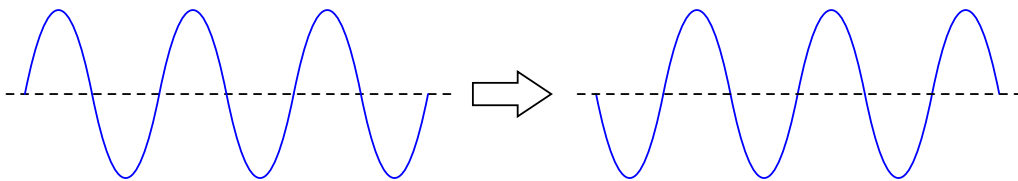

All one needs to do to see that these two waveforms are indeed identical is to do a 180 degree phase shift (shifting either to the left or to the right):

*(After the phase shift)*

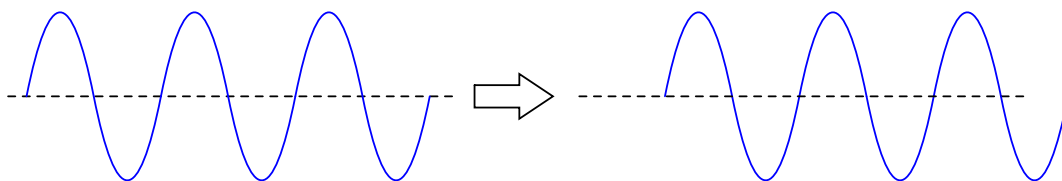

By contrast, a waveform without symmetry about the horizontal axis cannot be made to look the same after flipping, no matter what subsequent phase shift is given to it:

(Flipping waveform about the axis)

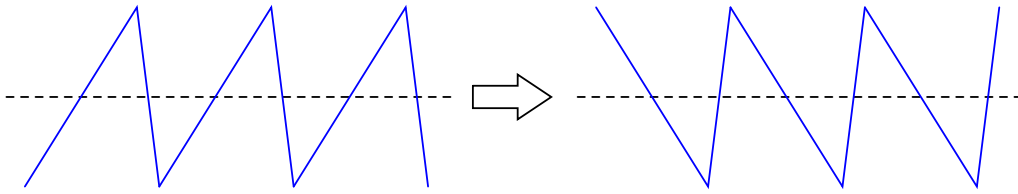

Another way to describe this asymmetry is in terms of the waveform's departure from the centerline, compared to its return to the centerline. Is the rate-of-change ( $\frac{dv}{dt}$  for a voltage waveform) equal in magnitude and opposite in sign at each of these points, or is there a difference in magnitude as well? Discuss ways to identify this type of asymmetry, and what it means in terms of harmonic content.

Mathematically, this symmetry is defined as such:

$$f(t) = -f\left(t + \frac{T}{2}\right)$$

Where,

$f(t)$  = Function of waveform with time as the independent variable

$t$  = Time

$T$  = Period of waveform, in same units of time as  $t$

---

Notes 12

I've had electrical power system experts confidently tell me that even-numbered harmonics *cannot* exist in AC power systems, due to some deep mathematical principle mysteriously beyond their ability to describe or explain. Rubbish! Even-numbered harmonics can and do appear in AC power systems, although they are typically much lower in amplitude than the odd-numbered harmonics due to the nature of most nonlinear loads.

If you ever wish to prove the existence of even-numbered harmonics in a power system, all you have to do is analyze the input current waveform of a half-wave rectifier!

---

Notes 13

Ask your students how they were able to discern the presence of even-numbered harmonics by visual inspection. This typically proves difficult for some of my students whose spatial-relations skills are weak. These students need some sort of algorithmic (step-by-step) procedure to see what other students see immediately, and discussion time is a great opportunity for students to share technique.

Mathematically, this symmetry is defined as such:

$$f(t) = -f\left(t + \frac{T}{2}\right)$$

Where,

$f(t)$  = Function of waveform with time as the independent variable

$t$  = Time

$T$  = Period of waveform, in same units of time as  $t$

---

Notes 14

The purpose of this question is to get students to realize the presence of harmonics means a departure from a once-perfect sinusoidal wave-shape. What used to be free of harmonics now contains harmonics, and this indicates distortion of the sine wave somewhere within the amplifier.

By the way, the perfectly flat "noise floor" at -120 dB is highly unusual. There will always be a "rough" floor shown on the display of a spectrum analyzer, but this is not pertinent to the question at hand so I omitted it for simplicity's sake.

---

Notes 15

This test circuit relies on the assumption that the notch filter is perfect (i.e. that its attenuation in the stop-band is complete). Since no filter is perfect, it would be a good idea to ask your students what effect they think an imperfect notch filter would have on the validity of the test. In other words, what will a notch filter that lets a little bit of the fundamental frequency through do to the "test" measurement?

---

Notes 16

The purpose of this question is to introduce the concept of the derivative to students in ways that are familiar to them. Hopefully the opening scenario of a dwindling savings account is something they can relate to!

A very important aspect of this question is the discussion it will engender between you and your students regarding the relationship between rates of change in the three equations given in the answer. It is very important to your students' comprehension of this concept to be able to verbally describe how the derivative works in each of these formulae. You may want to have them phrase their responses in realistic terms, as if they were describing how to set up an illustrative experiment for a classroom demonstration.

---

Notes 17

Usually students find the concept of the derivative easiest to understand in graphical form: being the *slope* of the graph. This is true whether or not the independent variable is time (an important point given that most "intuitive" examples of the derivative are time-based!).

---

Notes 18

Usually students find the concept of the derivative easiest to understand in graphical form: being the *slope* of the graph. This is true whether or not the independent variable is time (an important point given that most "intuitive" examples of the derivative are time-based!).

Even if your students are not yet familiar with the power rule for calculating derivatives, they should be able to tell that  $\frac{dy}{dx}$  is zero when  $x = 0$ , positive when  $x > 0$ , and negative when  $x < 0$ .

---

Notes 19

Here, I ask students to relate the instantaneous rate-of-change of the voltage waveform to the instantaneous amplitude of the current waveform. Just a conceptual exercise in derivatives.

---

Notes 20

This question really is best answered by experimentation. I recommend having a signal generator and oscilloscope on-hand in the classroom to demonstrate the operation of this passive differentiator circuit. Challenge students with setting up the equipment and operating it!

---

Notes 21

The goal of this question is to get students thinking in terms of derivative and integral every time they look at their car's speedometer/odometer, and ultimately to grasp the nature of these two calculus operations in terms they are already familiar with.

---

Notes 22

Ask your students to frame their answers in a practical context, such as speed and distance for a moving object (where speed is the time-derivative of distance and distance is the time-integral of speed).

---

Notes 23

This question introduces students to the concept of integration, following their prior familiarity with differentiation. Since they should already be familiar with other examples of inverse mathematical functions (arcsin, arccos, arctan, logs and powers, squares and roots, etc.), this should not be too much of a stretch. The fact that we may show them the cancellation of integration with differentiation should be proof enough.

In case you wish to demonstrate this principle "live" in the classroom, I suggest you bring a signal generator and oscilloscope to the class, and build the following circuit on a breadboard:

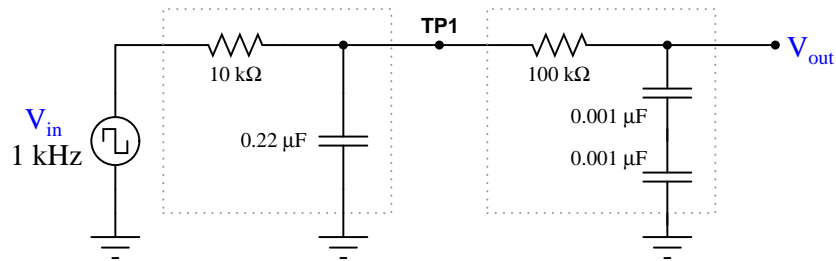

The output is not a perfect square wave, given the loading effects of the differentiator circuit on the integrator circuit, and also the imperfections of each operation (being passive rather than active integrator and differentiator circuits). However, the wave-shapes are clear enough to illustrate the basic concept.

---

Notes 24

Usually students find the concept of the integral a bit harder to grasp than the concept of the derivative, even when interpreted in graphical form. One way to help them make this "leap" is to remind them that integration and differentiation are inverse functions, then ask them to analyze the answer "backwards" (looking at the red integral plot and seeing how the blue function is the derivative of the red function). The thought process is analogous to explaining logarithms to students for the very first time: when we take the logarithm of a number, we are figuring out what power we would have to raise the base to get that number (e.g.  $\log 1000 = 3$  ;  $10^3 = 1000$ ). When we determine the integral of a function, we are figuring out what other function, when differentiated, would result in the given function. This is the essence of what we mean by *inverse functions*, and it is an important concept in algebra, trigonometry, and calculus alike.

---

Notes 25

The calculus relationships between position, velocity, and acceleration are fantastic examples of how time-differentiation and time-integration works, primarily because everyone has first-hand, tangible experience with all three. Everyone inherently understands the relationship between distance, velocity, and time, because everyone has had to travel somewhere at some point in their lives. Whenever you as an instructor can help bridge difficult conceptual leaps by appeal to common experience, do so!

---

Notes 26

This question asks students to relate the concept of time-differentiation to physical motion, as well as giving them a very practical example of how a passive differentiator circuit could be used. In reality, one must be very careful to use differentiator circuits for real-world signals because differentiators tend to amplify high-frequency noise. Since real-world signals are often "noisy," this leads to a lot of noise in the differentiated signals.



The purpose of this question is to have students apply the concepts of time-integration and time-differentiation to the variables associated with moving objects. I like to use the context of moving objects to teach basic calculus concepts because of its everyday familiarity: anyone who has ever driven a car knows what position, velocity, and acceleration are, and the differences between them.

One way I like to think of these three variables is as a verbal sequence:

*Differentiation* 

When we change **position** we create **velocity**.

When we change **velocity** we create **acceleration**.

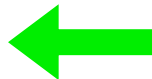
 *Integration*

Arranged as shown, differentiation is the process of stepping to the right (measuring the *rate of change* of the previous variable). Integration, then, is simply the process of stepping to the left.

Ask your students to come to the front of the class and draw their integrator and differentiator circuits. Then, ask the whole class to think of some scenarios where these circuits would be used in the same manner suggested by the question: motion signal processing. Having them explain how their schematic-drawn circuits would work in such scenarios will do much to strengthen their grasp on the concept of practical integration and differentiation.

This question simply puts students' comprehension of basic calculus concepts (and their implementation in electronic circuitry) to a practical test.

Your more alert students will note that the output voltage for a simple integrator circuit is of *inverse* polarity with respect to the input voltage, so the graphs should really look like this:

*Typical integrator response*

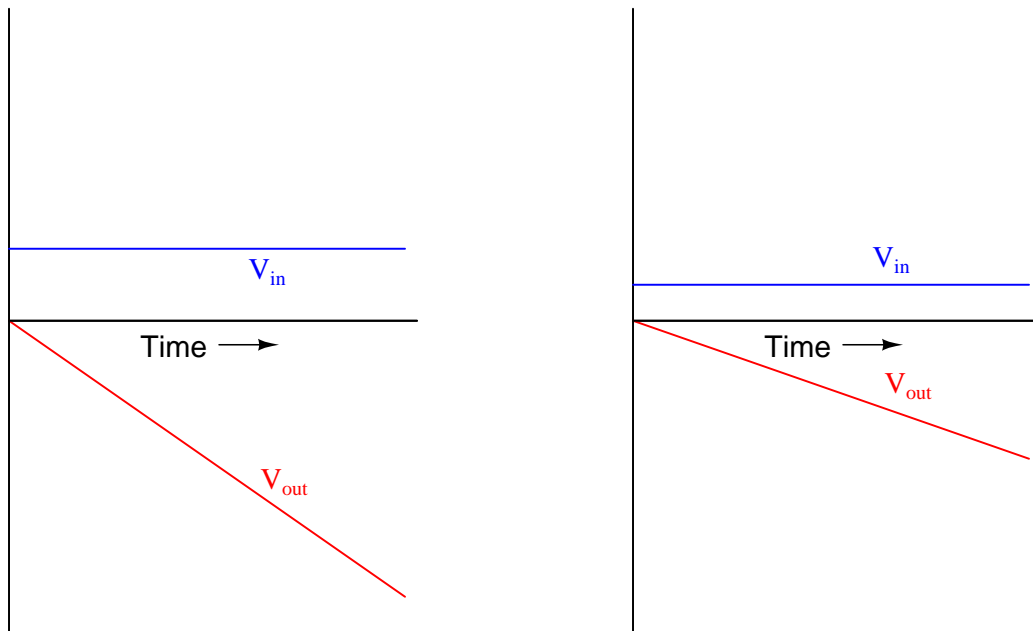

I have chosen to express all variables as positive quantities in order to avoid any unnecessary confusion as students attempt to grasp the concept of time integration.

---

Notes 30

This question provides a great opportunity to review Faraday's Law of electromagnetic induction, and also to apply simple calculus concepts to a practical problem. The coil's natural function is to *differentiate* the current going through the conductor, producing an output voltage proportional to the current's rate of change over time ( $v_{out} \propto \frac{di_{in}}{dt}$ ). The integrator's function is just the opposite. Discuss with your students how the integrator circuit "undoes" the natural calculus operation inherent to the coil (differentiation).

The subject of Rogowski coils also provides a great opportunity to review what mutual inductance is. Usually introduced at the beginning of lectures on transformers and quickly forgotten, the principle of mutual inductance is at the heart of every Rogowski coil: the coefficient relating instantaneous current change through one conductor to the voltage induced in an *adjacent* conductor (magnetically linked).

$$v_2 = M \frac{di_1}{dt}$$

Unlike the iron-core current transformers (CT's) widely used for AC power system current measurement, Rogowski coils are inherently linear. Being air-core devices, they lack the potential for saturation, hysteresis, and other nonlinearities which may corrupt the measured current signal. This makes Rogowski coils well-suited for high frequency (even RF!) current measurements, as well as measurements of current where there is a strong DC bias current in the conductor. By the way, this DC bias current may be "nulled" simply by re-setting the integrator after the initial DC power-up!

If time permits, this would be an excellent point of departure to other realms of physics, where op-amp signal conditioning circuits can be used to "undo" the calculus functions inherent to certain physical measurements (acceleration vs. velocity vs. position, for example).

---

Notes 31

The stock answer of "5 time constants" as the amount of time elapsed between the transient event and the "final" settling of voltage and current values is widespread, but largely misunderstood. I've encountered more than a few graduates of electronics programs who actually believe there is something special about the number 5, as though everything grinds to a halt at exactly 5 time constants worth of time after the switch closes.

In reality, the rule of thumb of "5 time constants" as a settling time in RC and LR circuits is an approximation only. Somewhere I recall reading an old textbook that specified *ten* time constants as the time required for all the variables to reach their final values. Another old book declared *seven* time constants. I think we're getting impatient as the years roll on!

---

Notes 32

Ask students to contrast the behavior of this passive differentiator circuit against that of a perfect differentiator (with  $\tau = 0$ ). What should the derivative plot of a square wave look like?

---

Notes 33

This question asks students to recognize conflicting design needs, and to balance one need against another. Very practical skills here, as real-life applications almost always demand some form of practical compromise in the design stage.

If students cannot figure out what must be sacrificed to achieve waveshape linearity, tell them to build such a circuit and see for themselves!

---

Notes 34

Explain to your students that although LR integrator circuits are possible, they are almost never used. RC circuits are much more practical. Ask them to determine why this is!

---

Notes 35

If students don't understand why this is, let them work through an example problem, to see what the output waveform(s) would look like for various periods and time constants. Remember to stress what an ideal integrator or differentiator is supposed to do!

---

Notes 36

This question is fairly easy, and provides a logical step to prepare students for frequency-domain analysis of passive integrator circuits.

---

Notes 37

Once students have a conceptual grasp on Fourier theory (that non-sinusoidal waveshapes are nothing more than series of superimposed sinusoids, all harmonically related), they possess a powerful tool for understanding new circuits such as this. Of course, it is possible to understand a circuit such as this from the perspective of the time domain, but being able to look at it from the perspective of the frequency domain provides one more layer of insight.

Incidentally, one may experiment with such a circuit using  $0.47 \mu\text{F}$  capacitors,  $1 \text{ k}\Omega$  resistors, and a fundamental frequency of about  $3 \text{ kHz}$ . Viewing the output waveform amplitudes with an oscilloscope is insightful, especially with regard to signal amplitude!

---

Notes 38

It is very important for students to understand what this expression means and how it works, lest they rely solely on memorization to use it in their calculations. As I always tell my students, rote memorization *will* fail you! If a student does not comprehend why the expression works as it does, they will be helpless to retain it as an effective "tool" for performing calculations in the future.

---

Notes 39

Be sure to have your students share their problem-solving techniques (how they determined which equation to use, etc.) in class.

---

Notes 40

This question is nothing more than an exercise in time-constant circuit calculations: determining how far the output voltage has decayed from its peak of 10 volts after 1 millisecond. Ask your students to share their techniques for problem-solving with the whole class.

---

Notes 41

This question is nothing more than an exercise in time-constant circuit calculations: determining how far the output voltage has decayed from its peak of 5 volts after  $150 \mu\text{s}$ . Ask your students to share their techniques for problem-solving with the whole class.

---

Notes 42

This question requires students to calculate a length of time in an RC circuit, given specific voltage levels and component values. It is a very practical question, as it may be necessary to build or troubleshoot such a circuit some day!

---

Notes 43

Be sure to have your students share their problem-solving techniques (how they determined which equation to use, etc.) in class. See how many of them notice that the exponential portion of the equation ( $e^{\frac{t}{\tau}}$ ) is the same for each calculation, and if they find an easy way to manage the calculations by storing charge/discharge percentages in their calculator memories!

---

---

Notes 44

Be sure to have your students share their problem-solving techniques (how they determined which equation to use, etc.) in class. See how many of them notice that the exponential portion of the equation ( $e^{\frac{t}{\tau}}$ ) is the same for each calculation, and if they find an easy way to manage the calculations by storing charge/discharge percentages in their calculator memories!

---

Notes 45

This is an interesting problem to set up. Ask your students what approach they used, so they all can see multiple problem-solving techniques. I based my own solution on the RC circuit decay equation  $e^{-t/\tau}$  with  $x$  volts being my starting condition and -6 volts being my final condition (if time  $t$  is infinite), then I just solved for  $x$ . With my method,  $x$  is the peak signal voltage, not the peak-to-peak, so I just doubled it to get the final answer.

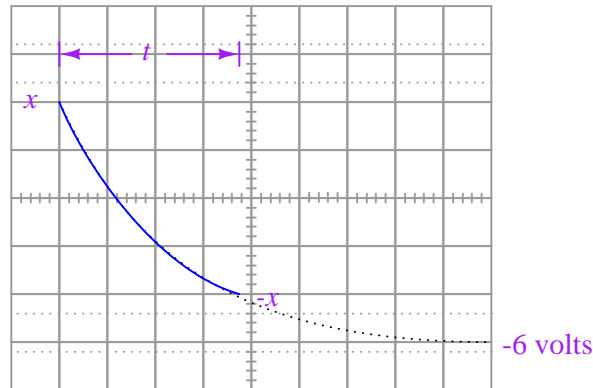

My own answer for the challenge question is this:

$$V_{out} = \frac{V_{in} \left( 1 - e^{\frac{-1}{2RCf}} \right)}{1 + e^{\frac{-1}{2RCf}}}$$

Your mileage may vary . . .

---

Notes 46

Really, the best way I've found for students to learn this principle is to experiment with a real oscilloscope and signal generator. I highly recommend setting up an oscilloscope and signal generator in the classroom during discussion time so that this may be demonstrated live.

---

Notes 47

This question previews the concept of oscilloscope triggering: waiting until an event occurs before plotting the shape of a moving waveform. Often I find new students relate better to such mechanical analogies than directly to electronic abstractions when first learning oscilloscope operation.

An important detail to note in this scenario is that the strobe will flash *four times* per fan rotation!

---

Notes 48

Triggering is a complex feature for students to grasp in even simple analog oscilloscopes. Spend as much time with students as you must to give them understanding in this area, as it will be very useful in their labwork and eventually in their careers.

---

Notes 49

The location of the knob should be easy for students to determine. More difficult perhaps is the explanation of the knob's function.

---

Notes 50

There is nothing special about a triangle wave here. To be perfectly honest, it was the easiest waveform for me to draw which had a sloping edge to trigger on!

By the way, for students to really understand how triggering works, it is important for them to spend time "playing" with an oscilloscope and a signal generator trying things like this. There is only so much one can learn about the operation of a machine by reading!

---

Notes 51

There is nothing special about a triangle wave here. To be perfectly honest, it was the easiest waveform for me to draw which had a sloping edge to trigger on!

By the way, for students to really understand how triggering works, it is important for them to spend time "playing" with an oscilloscope and a signal generator trying things like this. There is only so much one can learn about the operation of a machine by reading!

---

Notes 52

Ask your students to explain which mode they think the oscilloscope should ordinarily be set in for general-purpose use.

---

Notes 53

"Line" triggering is a very useful feature, especially for working on line-powered and line-synchronized circuits. SCR- and TRIAC-based motor control circuits come immediately to mind here, as do brute-force (linear) power supply circuits!

---

Notes 54

There are many electronic (non-mechanical) examples one could use to illustrate the use of external triggering. I like to introduce something like this once in a while to broaden students' thoughts beyond the world of tiny components and circuit boards. The practical applications of electronics are legion!

---

Notes 55

In order for students to successfully answer this question, they must grasp the function of the circuit itself. Discuss with them why and how the rheostat is able to change the amount of DC "bias" voltage imposed on the AC signal, then progress to discussing the oscilloscope's triggering.

---

Notes 56

This is a very realistic scenario, one that your students will surely encounter when they build their own AC-DC power supply circuits. Ripple voltage, being such a small AC quantity superimposed on such a (relatively) large DC bias, is quite a challenge for the new student to "lock in" on his or her oscilloscope screen.

Be sure to discuss options other than line triggering. Also be sure to discuss *why* line triggering works in this situation. It is not a panacea for triggering all low-amplitude waveforms, by any means! It just happens to work in this scenario because the ripple voltage is a direct function of the AC line voltage, and as such is harmonically related.

---

Notes 57

This question came from direct, personal experience. I was once working on the construction of a servo motor control system for positioning rotary valves, and we were having problems with the motors tripping the overcurrent limits upon start-up. I needed to measure the typical inrush current magnitude and duration. Fortunately, I had a digital storage oscilloscope at my disposal, and I set up this very circuit to do the measurements. About a half-hour of work setting up all the components, and I had the information I needed. The digital oscilloscope also provided me with digital "screenshot" images that I could email to engineers working on the project with me, so they could see the same data I was seeing.

---

Notes 58

A purposefully minimal answer (as usual!) is shown in the answer section for this question. Understanding how holdoff works may very well require hands-on experience for some students, so I highly recommend setting up a demonstration in the classroom to use while discussing this oscilloscope feature.

---

Notes 59

Like so many oscilloscope principles, this is perhaps best understood through actually using an oscilloscope. Try to set up two signal generators and an oscilloscope in your classroom so that you may demonstrate these controls while discussing them with your students.

---

Notes 60

Finding the controls on the oscilloscope panel should present no difficulty for most students, at least once they realize what the controls are called. The key to answering this question is to research the words "rejection" and "trigger" in the context of oscilloscope controls.

---

Notes 61

Use a sine-wave function generator for the AC voltage source, and be sure set the frequency to some reasonable value (well within the capability of both the oscilloscope and counter to measure).

Some digital oscilloscopes have "auto set" controls which automatically set the vertical, horizontal, and triggering controls to "lock in" a waveform. Be sure students are learning how to set up these controls on their own rather than just pushing the "auto set" button!

---

Notes 62

Here, students must calculate values for  $C_1$  and  $R_1$  that will produce the  $V_{out}$  waveshape specified in the "Given conditions" oscilloscope plot. The input signal, of course, is a square wave. Students should be able to show mathematically why the time constant of the integrator ( $\tau$ ) must be 69.3% of the waveform's half-period. Instructors, note: the calculations for this circuit, with  $V_{out} = \frac{1}{3}V_{in}$ , are exactly the same as for a 555 timer circuit, because 555 timers also cycle their capacitors' voltages at peak-to-peak values equal to one-third of the supply voltage.

There are many different combinations of values for  $C_1$  and  $R_1$  possible for any given square-wave signal frequencies. The purpose of this exercise is for students to be able to predict and select practical component values from their parts kits.

An extension of this exercise is to incorporate troubleshooting questions. Whether using this exercise as a performance assessment or simply as a concept-building lab, you might want to follow up your students' results by asking them to predict the consequences of certain circuit faults.

---

Notes 63

Here, students must calculate values for  $C_1$  and  $R_1$  that will produce the  $V_{out}$  waveshape specified in the "Given conditions" oscilloscope plot. The input signal, of course, is a square wave. Students must calculate the time constant of the circuit ( $\tau$ ) such that the pulse fully decays within the pulse width (half-period) of the square wave. With  $5\tau$  being the accepted standard for full charge/discharge of a time-constant circuit, this is an easy calculation.

There are many different combinations of values for  $C_1$  and  $R_1$  possible for any given square-wave signal frequencies. The purpose of this exercise is for students to be able to predict and select practical component values from their parts kits.

An extension of this exercise is to incorporate troubleshooting questions. Whether using this exercise as a performance assessment or simply as a concept-building lab, you might want to follow up your students' results by asking them to predict the consequences of certain circuit faults.

---

Notes 64

The purpose of this assessment rubric is to act as a sort of "contract" between you (the instructor) and your student. This way, the expectations are all clearly known in advance, which goes a long way toward disarming problems later when it is time to grade.

---

Notes 65

Ask your students to determine the mathematical relationship between harmonic number, harmonic frequency, and fundamental frequency. It isn't difficult to figure out!

---

Notes 66

To be honest, the four-harmonic equivalent circuit is a rather poor approximation for a square wave. The real purpose of this question, though, is to have students relate the sinusoidal terms of a common Fourier series (for a square wave) to a schematic diagram, translating between angular velocity and frequency, peak values and RMS values.

Please note that the voltage magnitudes shown in the answer are *RMS* and not peak! If you were to calculate peak sinusoid source values, you would obtain these results:

- 1st harmonic:  $\frac{40}{\pi}$  volts peak = 12.73 volts peak
  - 3rd harmonic:  $\frac{40}{3\pi}$  volts peak = 4.244 volts peak
  - 5th harmonic:  $\frac{40}{5\pi}$  volts peak = 2.546 volts peak
  - 7th harmonic:  $\frac{40}{7\pi}$  volts peak = 1.819 volts peak
- 

Notes 67

The purpose of this question is to have students relate the sinusoidal terms of a particular Fourier series to a schematic diagram, translating between angular velocity and frequency, peak values and RMS values.

---

Notes 68

At first, some students have trouble understanding exactly how Fourier analysis is helpful in any practical way as an analytical tool. The purpose of this question is to have them see how it might be applied to something they are familiar with: an LR circuit.

---

Notes 69

The answer given here is correct, but vague. I did not specify the type of filter or exactly how it might be connected to a load. These are questions to ask your students during discussion.

---



---

Notes 70

Ask your students how they were able to discern the presence of even-numbered harmonics by visual inspection. This typically proves difficult for some of my students whose spatial-relations skills are weak. These students need some sort of algorithmic (step-by-step) procedure to see what other students see immediately, and discussion time is a great opportunity for students to share technique.

Mathematically, this symmetry is defined as such:

$$f(t) = -f\left(t + \frac{T}{2}\right)$$

Where,

$f(t)$  = Function of waveform with time as the independent variable

$t$  = Time

$T$  = Period of waveform, in same units of time as  $t$

---

Notes 71

Be sure to ask your students what "AM" and "FM" mean, before they present their answers on sidebands.

The answer makes frequent use of the word *carrier* without defining it. This is another intentional "omission" designed to make students do their research. If they have taken the time to find information on sidebands, they will surely discover what the word "carrier" means. Ask them to define this word, in addition to their description of sidebands.

---

Notes 72

Many students find this a helpful analogy of capacitor action. But it helps even more if students work together to *build* the analogy, and to truly understand it.

Perform some "thought experiments" with vessels of different size, relating the outcomes to charge storage in capacitors of different size.

---

Notes 73

Emphasize to your students that inductance is an essentially *reactive* property, opposing change in current over time. It is not steady current that inductors react to, only changing current.

---

Notes 74

Emphasize to your students that capacitance is an essentially *reactive* property, opposing change in voltage over time. It is not steady voltage that capacitors react to, only changing voltage.

---

Notes 75

Explain to your students how the similarities between inertia and inductance are so close, that inductors can be used to electrically model mechanical inertia.

---

Notes 76

Note to your students that spring stiffness ( $k$ ) and capacitance ( $C$ ) are inversely proportional to one another in this analogy.

Explain to your students how the similarities between inertia and capacitance are so close, that capacitors can be used to electrically model mechanical springs!

---

Notes 77

The answer given here is purposely minimal. You should ask your students to give responses more thoughtful than this! Ask them why capacitors are cheaper than inductors. Ask them to explain what is meant by "easier to work with," in technical terms.

---

Notes 78

While some may wonder what this question has to do with electronics, it is an exercise in qualitative analysis. This skill is very important for students to master if they are to be able to distinguish between the equations  $e^{-\frac{t}{\tau}}$  and  $1 - e^{-\frac{t}{\tau}}$ , both used in time-constant circuit analysis.

The actual procedure for determining the nature of the equation is simple: consider what happens as  $t$  begins at 0 and as it increases to some arbitrary positive value. Some students may rely on their calculators, performing actual calculations to see whether the percentage increases or decreases with increasing  $t$ . Encourage them to analyze the equation qualitatively rather than quantitatively, though. They should be able to tell which way the percentage changes with time without having to consider a single numerical value!

---

Notes 79

The behavior of a differentiator circuit may be confusing to students with exposure to calculus, because the output of such a circuit is not *strictly* related to the rate of change of the input voltage over time. However, if the time constant of the circuit is short in comparison to the period of the input signal, the result is close enough for many applications.

That integration and differentiation are inverse functions will probably be obvious already to your more mathematically inclined students. To others, it may be a revelation.

If time permits, you might want to elaborate on the limits of this complementarity. As anyone with calculus background knows, integration introduces an arbitrary constant of integration. So, if the integrator stage follows the differentiator stage, there may be a DC bias added to the output that is not present in the input (or visa-versa!).

$$\int \frac{d}{dx} [f(x)] dx = f(x) + C$$

In a circuit such as this where integration precedes differentiation, ideally there is no DC bias (constant) loss:

$$\frac{d}{dx} \left[ \int f(x) dx \right] = f(x)$$

However, since these are actually first-order "lag" and "lead" networks rather than true integration and differentiation stages, respectively, a DC bias applied to the input will *not* be faithfully reproduced on the output. Whereas a true integrator would take a DC bias input and produce an output with a linearly ramping bias, a passive integrator will assume an output bias equal to the input bias.<sup>†</sup> Therefore, the subsequent differentiation stage, perfect or not, has no slope to differentiate, and thus there will be no DC bias on the output.

Incidentally, the following values work well for a demonstration circuit:

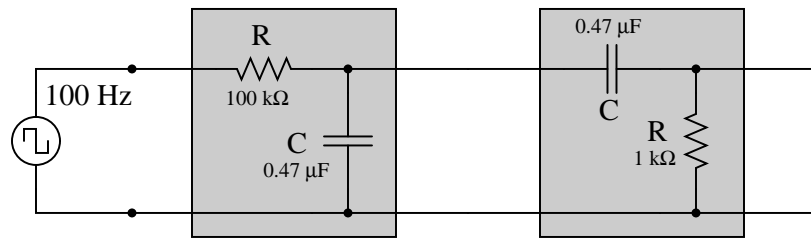

There are only two components in this circuit, so determining possible failures should not be a problem at all. To distinguish between the inductor having failed versus the resistor having failed, one needs to know which type of component failures are more likely (and why!).

As an interesting footnote, this is precisely why differentiation is rarely performed on real-world signals. Since the frequency of noise often exceeds the frequency of the signal, differentiating a "noisy" signal will only lead to a decreased signal-to-noise ratio.

For a practical example of this, tell your students about vibration measurement, where it is more common to calculate velocity based on time-integration of an acceleration signal than it is to calculate acceleration based on time-differentiation of a velocity signal.

<sup>†</sup> If this is not apparent to you, I suggest performing Superposition analysis on a passive integrator (consider AC, then consider DC separately), and verify that  $V_{DC(out)} = V_{DC(in)}$ . A passive differentiator circuit would have to possess an infinite time constant ( $\tau = \infty$ ) in order to generate this ramping output bias!