

## ELTR 135 (Operational Amplifiers 2), section 1

### Recommended schedule

---

#### Day 1

Topics: *Operational amplifier AC performance*  
Questions: *1 through 10*  
Lab Exercise: *Opamp slew rate (question 56)*

---

#### Day 2

Topics: *AC calculations and filter circuit review*  
Questions: *11 through 25*  
Lab Exercise: *Opamp gain-bandwidth product (question 57)*

---

#### Day 3

Topics: *Active filter circuits*  
Questions: *26 through 35*  
Lab Exercise: *Sallen-Key active lowpass filter (question 58)*

---

#### Day 4

Topics: *Active filter circuits (continued)*  
Questions: *36 through 45*  
Lab Exercise: *Sallen-Key active highpass filter (question 59)*

---

#### Day 5

Topics: *Switched-capacitor circuits (optional)*  
Questions: *46 through 55*  
Lab Exercise: *Bandpass active filter (question 60)*

---

#### Day 6

Exam 1: *includes Active filter circuit performance assessment*  
Lab Exercise: *Work on project*

---

#### Troubleshooting practice problems

Questions: *62 through 71*

---

#### General concept practice and challenge problems

Questions: *72 through the end of the worksheet*

---

#### Impending deadlines

**Project due at end of ELTR135, Section 2**  
Question 61: Sample project grading criteria

Skill standards addressed by this course section

---

*EIA Raising the Standard: Electronics Technician Skills for Today and Tomorrow, June 1994*

**E Technical Skills – Analog Circuits**

- E.10 Understand principles and operations of operational amplifier circuits.
- E.11 Fabricate and demonstrate operational amplifier circuits.
- E.12 Troubleshoot and repair operational amplifier circuits.
- E.18 Understand principles and operations of active filter circuits.
- E.19 Troubleshoot and repair active filter circuits.

**B Basic and Practical Skills – Communicating on the Job**

- B.01 Use effective written and other communication skills. *Met by group discussion and completion of labwork.*
- B.03 Employ appropriate skills for gathering and retaining information. *Met by research and preparation prior to group discussion.*
- B.04 Interpret written, graphic, and oral instructions. *Met by completion of labwork.*
- B.06 Use language appropriate to the situation. *Met by group discussion and in explaining completed labwork.*
- B.07 Participate in meetings in a positive and constructive manner. *Met by group discussion.*
- B.08 Use job-related terminology. *Met by group discussion and in explaining completed labwork.*
- B.10 Document work projects, procedures, tests, and equipment failures. *Met by project construction and/or troubleshooting assessments.*

**C Basic and Practical Skills – Solving Problems and Critical Thinking**

- C.01 Identify the problem. *Met by research and preparation prior to group discussion.*
- C.03 Identify available solutions and their impact including evaluating credibility of information, and locating information. *Met by research and preparation prior to group discussion.*
- C.07 Organize personal workloads. *Met by daily labwork, preparatory research, and project management.*
- C.08 Participate in brainstorming sessions to generate new ideas and solve problems. *Met by group discussion.*

**D Basic and Practical Skills – Reading**

- D.01 Read and apply various sources of technical information (e.g. manufacturer literature, codes, and regulations). *Met by research and preparation prior to group discussion.*

**E Basic and Practical Skills – Proficiency in Mathematics**

- E.01 Determine if a solution is reasonable.
- E.02 Demonstrate ability to use a simple electronic calculator.
- E.05 Solve problems and [sic] make applications involving integers, fractions, decimals, percentages, and ratios using order of operations.
- E.06 Translate written and/or verbal statements into mathematical expressions.
- E.09 Read scale on measurement device(s) and make interpolations where appropriate. *Met by oscilloscope usage.*
- E.12 Interpret and use tables, charts, maps, and/or graphs.
- E.13 Identify patterns, note trends, and/or draw conclusions from tables, charts, maps, and/or graphs.
- E.15 Simplify and solve algebraic expressions and formulas.
- E.16 Select and use formulas appropriately.
- E.17 Understand and use scientific notation.
- E.18 Use properties of exponents and logarithms.

Common areas of confusion for students

---

**Difficult concept:** *Trigonometry and phasor diagrams.*

AC circuit calculations tend to be difficult, if only because of all the math involved. There is no way around this problem except to strengthen one's math competence, hence the review questions at the end of this worksheet.

**Difficult concept:** *Identifying filter circuit types.*

Many students have a predisposition to memorization (as opposed to comprehension of concepts), and so when approaching filter circuits they try to identify the various types by memorizing the positions of reactive components. As I like to tell my students, *memory will fail you*, and so a better approach is to develop analytical techniques by which you may determine circuit function based on "first principles" of circuits. The approach I recommend begins by identifying component impedance (open or short) for very low and very high frequencies, respectively, then qualitatively analyzing voltage drops under those extreme conditions. If a filter circuit outputs a strong voltage at low frequencies and a weak voltage at high frequencies then it must be a low-pass filter. If it outputs a weak voltage at both low and high frequencies then it must be a band-pass filter, etc.

## Questions

### Question 1

In a common-emitter transistor amplifier circuit, the presence of capacitance between the collector and base terminals – whether intrinsic to the transistor or externally connected – has the effect of turning the amplifier circuit into a low-pass filter, with voltage gain being inversely proportional to frequency:

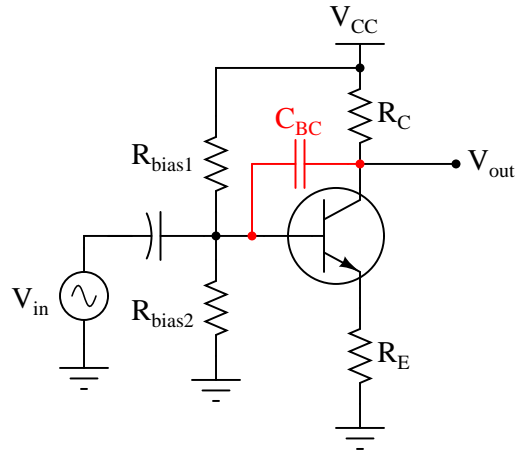

Explain why this is. Why, exactly, does a capacitance placed in this location affect voltage gain? Hint: it has something to do with *negative feedback*!

[file 02594](#)

### Question 2

Which of the following amplifier circuits will be most affected by the base-collector capacitance (shown here as an externally-connected 10 pF capacitor) as frequency increases? Explain why.

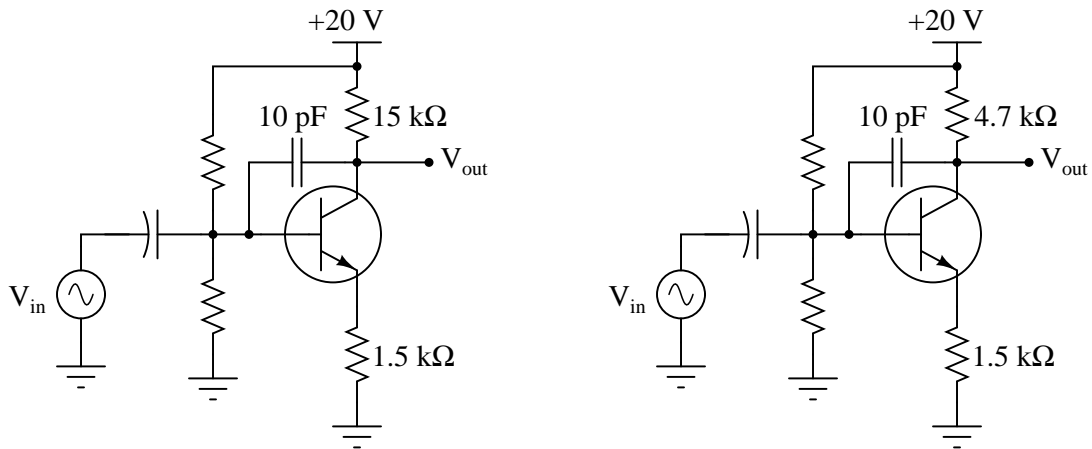

[file 02595](#)

---

### Question 3

A common problem encountered in the development of transistor amplifier circuits is unwanted oscillation resulting from parasitic capacitance and inductance forming a positive feedback loop from output to input. Often, these parasitic parameters are quite small (nanohenrys and picofarads), resulting in very high oscillation frequencies.

Another parasitic effect in transistor amplifier circuits is *Miller-effect* capacitance between the transistor terminals. For common-emitter circuits, the base-collector capacitance ( $C_{BC}$ ) is especially troublesome because it introduces a feedback path for AC signals to travel directly from the output (collector terminal) to the input (base terminal).

Does this parasitic base-to-collector capacitance encourage or discourage high-frequency oscillations in a common-emitter amplifier circuit? Explain your answer.

[file 02601](#)

---

### Question 4

A student connects a model CA3130 operational amplifier as a voltage follower (or voltage buffer), which is the simplest type of negative feedback op-amp circuit possible:

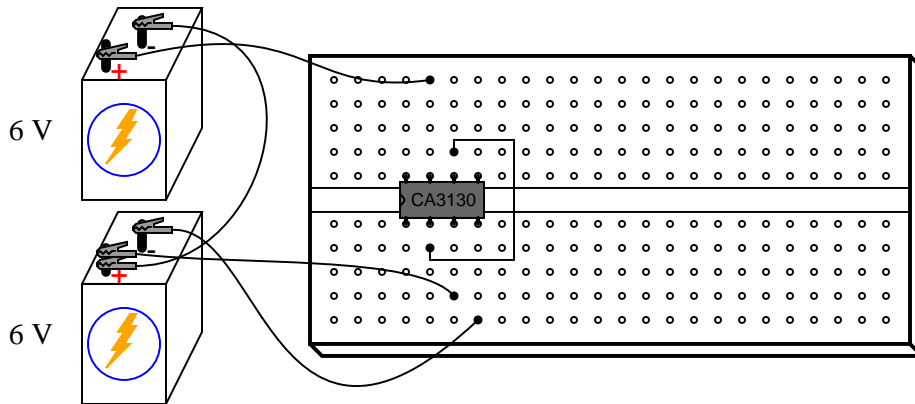

With the noninverting input connected to ground (the midpoint in the split +6/-6 volt power supply), the student expects to measure 0 volts DC at the output of the op-amp. This is what the DC voltmeter registers, but when set to AC, it registers substantial AC voltage!

Now this is strange. How can a simple voltage buffer output *alternating current* when its input is grounded and the power supply is pure DC? Perplexed, the student asks the instructor for help. "Oh," the instructor says, "you need a compensation capacitor between pins 1 and 8." What does the instructor mean by this cryptic suggestion?

[file 00942](#)

---

Question 5

Some operational amplifiers come equipped with compensation capacitors built inside. The classic 741 design is one such opamp:

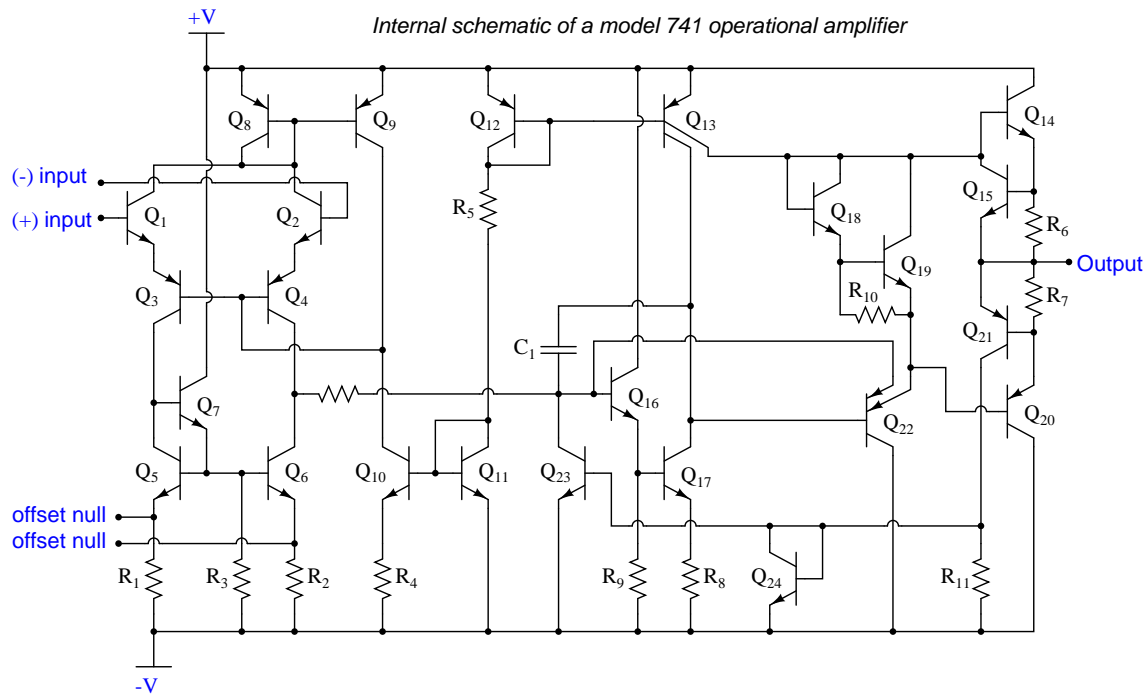

Find the compensation capacitor in this schematic diagram, and identify how it provides frequency-dependent negative feedback within the opamp to reduce gain at high frequencies.

[file 02592](#)

---

Question 6

Some operational amplifiers are *internally compensated*, while others are *externally compensated*. Explain the difference between the two. Hint: examples of each include the classic LM741 and LM101 operational amplifiers. Research their respective datasheets to see what you find on compensation!

[file 02600](#)

---

Question 7

Define "Gain-Bandwidth Product" (GBW) as the term applies to operational amplifiers.

[file 02593](#)

---

Question 8

Define "Unity-Gain Bandwidth" ( $B_1$ ) as the term applies to operational amplifiers.

[file 02604](#)

---

Question 9

Explain the effect that compensation capacitance has on an operational amplifier's gain-bandwidth product (GBW). Does a larger compensation capacitance yield a greater GBW or a lesser GBW, and why?

[file 00980](#)

---

Question 10

An important AC performance parameter for operational amplifiers is *slew rate*. Explain what "slew rate" is, and what causes it to be less than optimal for an opamp.

[file 02602](#)

---

Question 11

Which component, the resistor or the capacitor, will drop more voltage in this circuit?

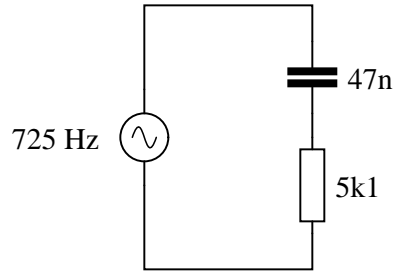

Also, calculate the total impedance ( $Z_{total}$ ) of this circuit, expressing it in both rectangular and polar forms.

[file 03784](#)

---

Question 12

In very simple, qualitative terms, rate the impedance of capacitors and inductors as "seen" by low-frequency and high-frequency signals alike:

- Capacitor as it "appears" to a low frequency signal: (high or low) impedance?
- Capacitor as it "appears" to a high frequency signal: (high or low) impedance?
- Inductor as it "appears" to a low frequency signal: (high or low) impedance?
- Inductor as it "appears" to a high frequency signal: (high or low) impedance?

[file 00616](#)

---

Question 13

Identify these filters as either being "low-pass" or "high-pass", and be prepared to explain your answers:

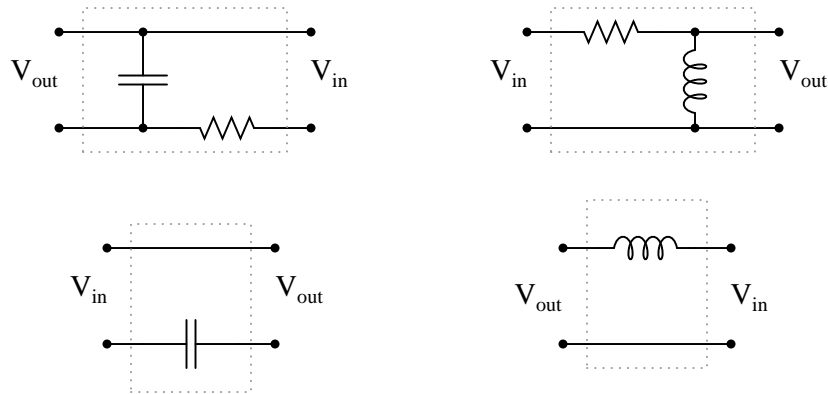

[file 00615](#)

---

Question 14

Identify what type of filter this circuit is, and calculate its cutoff frequency given a resistor value of  $1\text{ k}\Omega$  and a capacitor value of  $0.22\ \mu\text{F}$ :

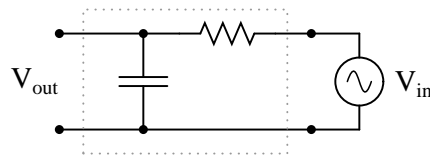

Calculate the impedance of both the resistor and the capacitor at this frequency. What do you notice about these two impedance values?

[file 00617](#)

---

Question 15

The formula for determining the cutoff frequency of a simple LR filter circuit looks substantially different from the formula used to determine cutoff frequency in a simple RC filter circuit. Students new to this subject often resort to memorization to distinguish one formula from the other, but there is a better way.

In simple filter circuits (comprised of one reactive component and one resistor), cutoff frequency is that frequency where circuit reactance equals circuit resistance. Use this simple definition of cutoff frequency to derive both the RC and the LR filter circuit cutoff formulae, where  $f_{cutoff}$  is defined in terms of  $R$  and either  $L$  or  $C$ .

[file 02075](#)

---

Question 16

The following schematic shows the workings of a simple AM radio receiver, with transistor amplifier:

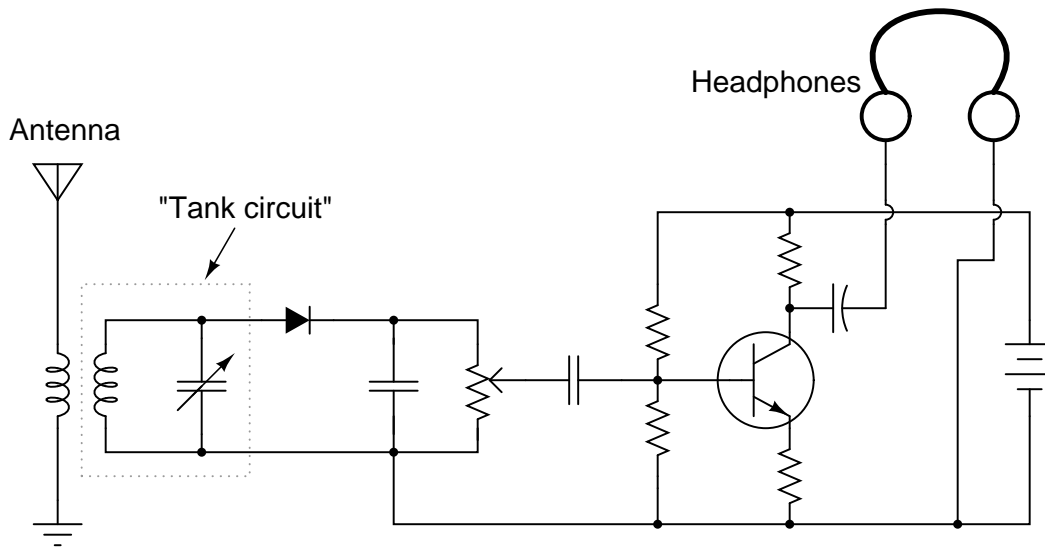

The "tank circuit" formed of a parallel-connected inductor and capacitor network performs a very important filtering function in this circuit. Describe what this filtering function is.

[file 00611](#)



Question 17

Identify each of these filter types, and explain *how* you were able to positively identify their behaviors:

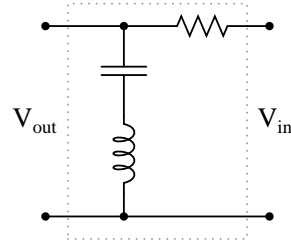
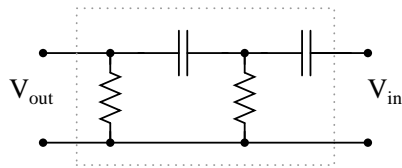
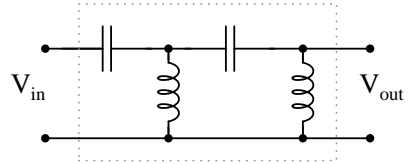
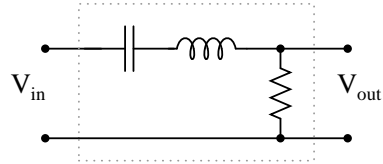
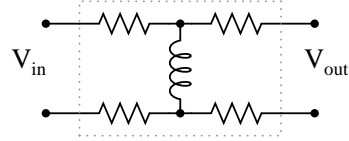
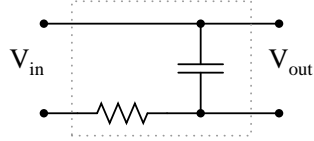

file 02098

Question 18

Identify the following filter types, and be prepared to explain your answers:

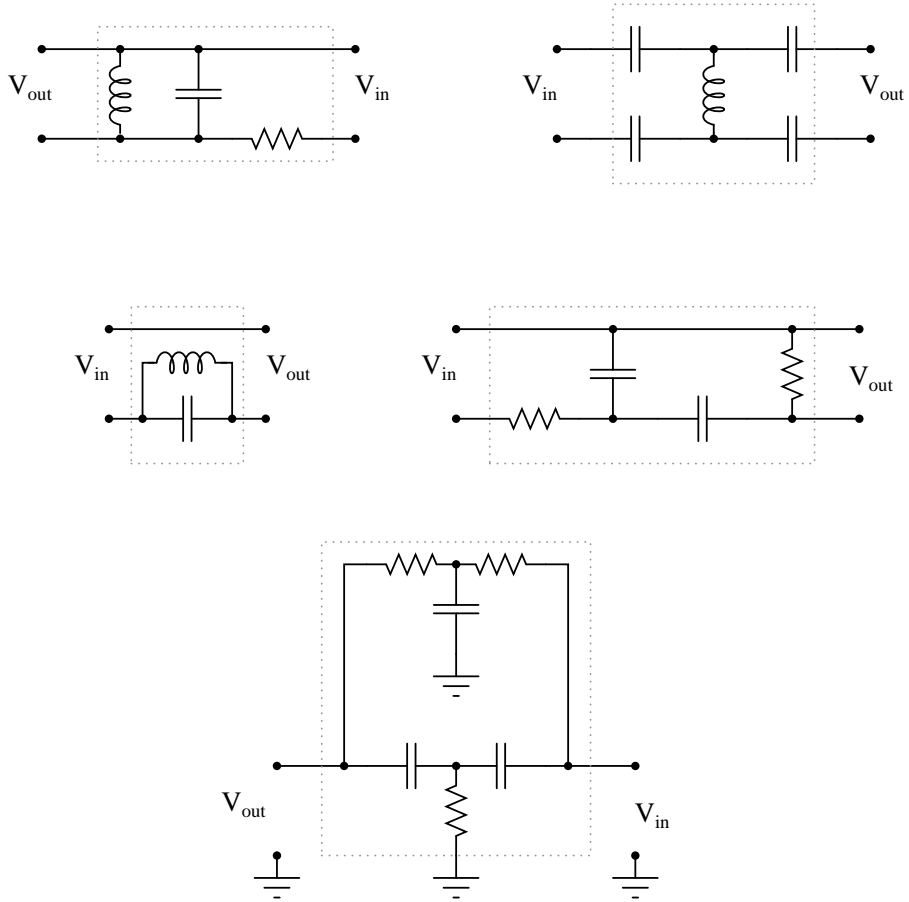

file 00620

## Question 19

An interesting technology dating back at least as far as the 1940's, but which is still of interest today is *power line carrier*: the ability to communicate information as well as electrical power over power line conductors. Hard-wired electronic data communication consists of high-frequency, low voltage AC signals, while electrical power is low-frequency, high-voltage AC. For rather obvious reasons, it is important to be able to separate these two types of AC voltage quantities from entering the wrong equipment (especially the high-voltage AC power from reaching sensitive electronic communications circuitry).

Here is a simplified diagram of a power-line carrier system:

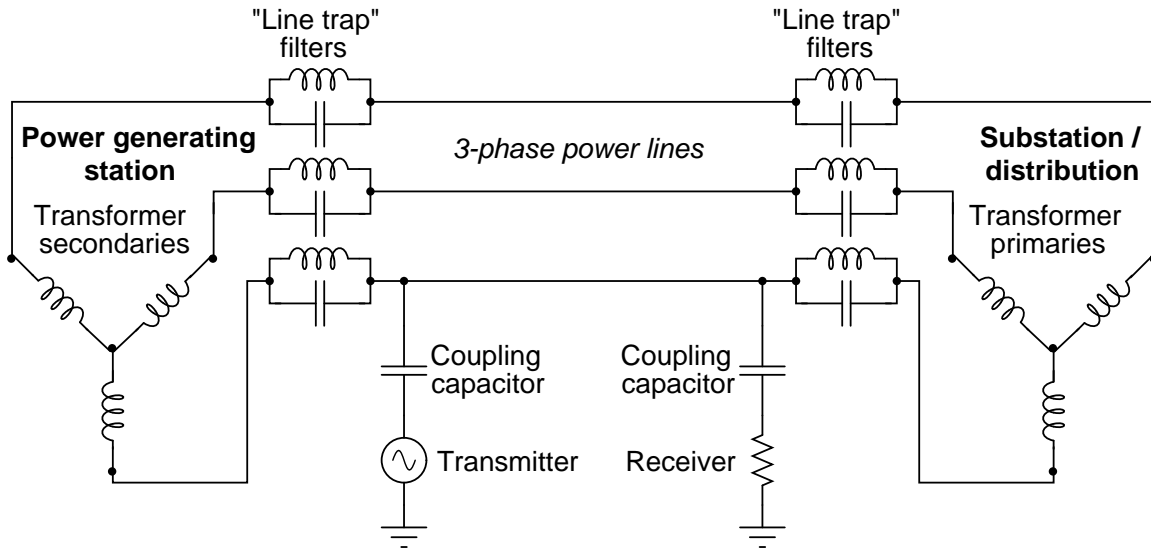

The communications transmitter is shown in simplified form as an AC voltage source, while the receiver is shown as a resistor. Though each of these components is much more complex than what is suggested by these symbols, the purpose here is to show the transmitter as a *source* of high-frequency AC, and the receiver as a *load* of high-frequency AC.

Trace the complete circuit for the high-frequency AC signal generated by the "Transmitter" in the diagram. How many power line conductors are being used in this communications circuit? Explain how the combination of "line trap" *LC* networks and "coupling" capacitors ensure the communications equipment never becomes exposed to high-voltage electrical power carried by the power lines, and visa-versa.

[file 01393](#)

---

Question 20

Plot the typical frequency responses of four different filter circuits, showing signal output (amplitude) on the vertical axis and frequency on the horizontal axis:

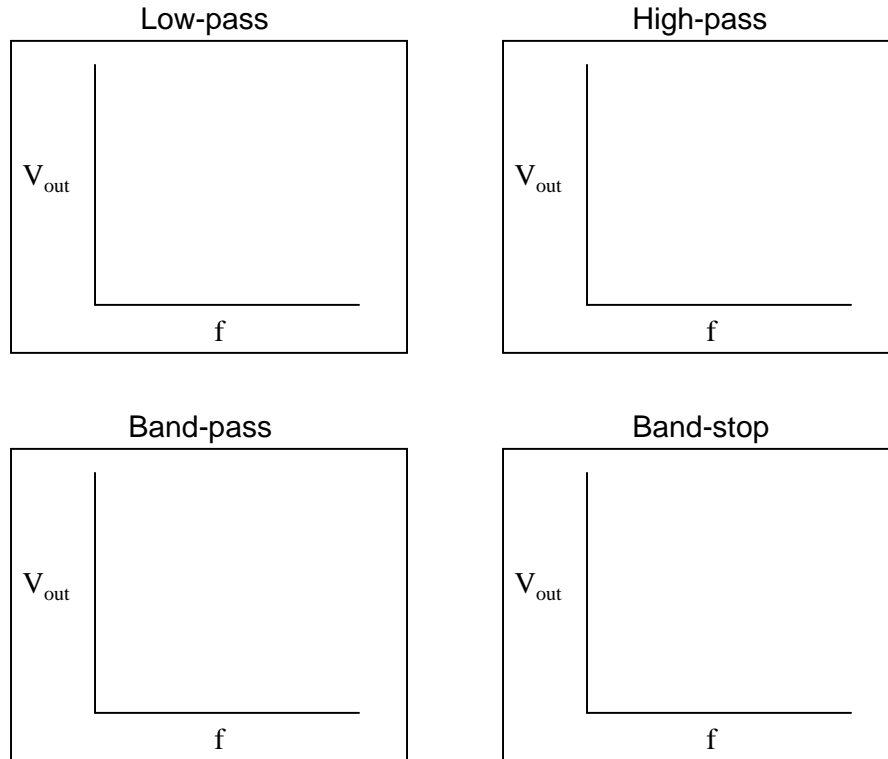

Also, identify and label the *bandwidth* of the filter circuit on each plot.

[file 02571](#)

---

Question 21

The Q factor of a series inductive circuit is given by the following equation:

$$Q = \frac{X_L}{R_{series}}$$

Likewise, we know that inductive reactance may be found by the following equation:

$$X_L = 2\pi fL$$

We also know that the resonant frequency of a series LC circuit is given by this equation:

$$f_r = \frac{1}{2\pi\sqrt{LC}}$$

Through algebraic substitution, write an equation that gives the Q factor of a series resonant LC circuit exclusively in terms of  $L$ ,  $C$ , and  $R$ , without reference to reactance ( $X$ ) or frequency ( $f$ ).

[file 01683](#)

---

Question 22

Filter circuits don't just attenuate signals, they also shift the phase of signals. Calculate the amount of phase shift that these two filter circuits impart to their signals (from input to output) operating at the cutoff frequency:

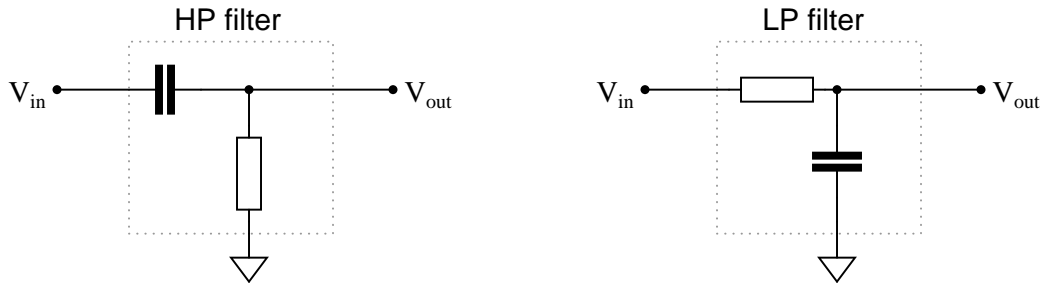

[file 03785](#)

---

Question 23

Determine the input frequency necessary to give the output voltage a phase shift of  $40^\circ$ :

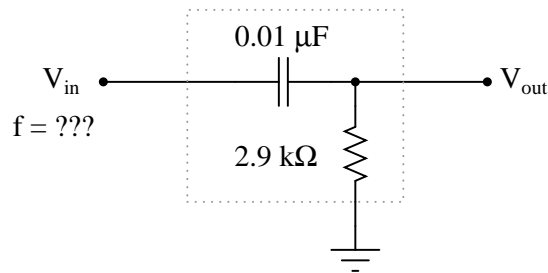

[file 02622](#)

---

Question 24

Determine the input frequency necessary to give the output voltage a phase shift of  $-38^\circ$ :

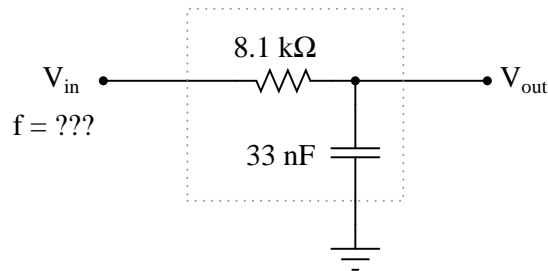

[file 02626](#)

---

Question 25

This phase-shifting bridge circuit is supposed to provide an output voltage with a variable phase shift from  $-45^\circ$  (lagging) to  $+45^\circ$  (leading), depending on the position of the potentiometer wiper:

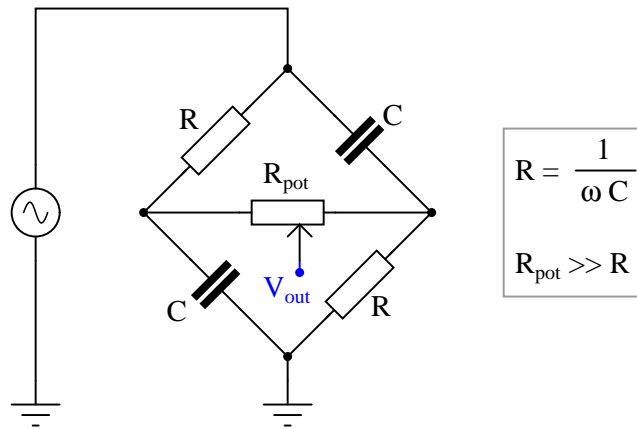

Suppose, though, that the output signal is stuck at  $-45^\circ$  lagging the source voltage, no matter where the potentiometer is set. Identify a likely failure that could cause this to happen, and explain why this failure could account for the circuit's strange behavior.

file 03465

---

Question 26

Identify what factor(s) determine the cutoff frequency of this passive filter circuit:

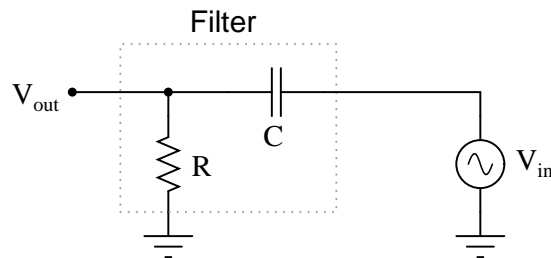

Give an exact equation predicting this filter circuit's cutoff frequency, and also identify what type of filter it is.

file 02572

---

Question 27

In this passive filter circuit, how will the filter's cutoff frequency be affected by changes in the load resistance? Be as specific as you can in your answer.

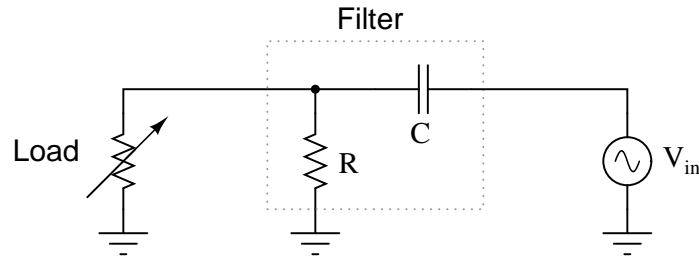

file 00701

---

Question 28

In this active filter circuit, how will the filter's cutoff frequency be affected by changes in the load resistance? Be as specific as you can in your answer.

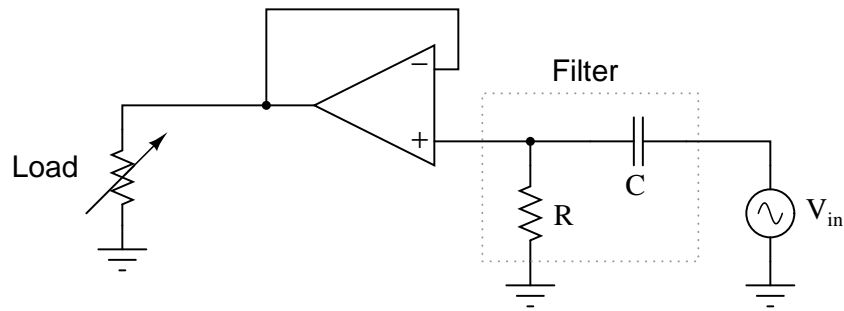

file 00702

---

Question 29

In this filter circuit, how will the filter's cutoff frequency be affected by changes in the potentiometer position? Be as specific as you can in your answer.

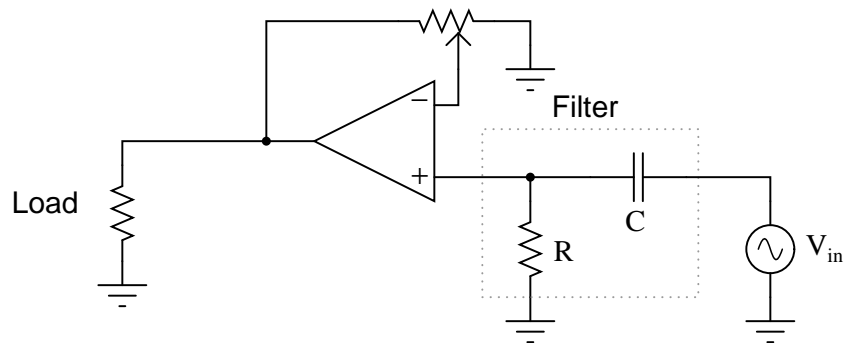

file 00703

---

Question 30

Determine the type (LP, HP, BP, BS) and cutoff frequency of this active filter circuit:

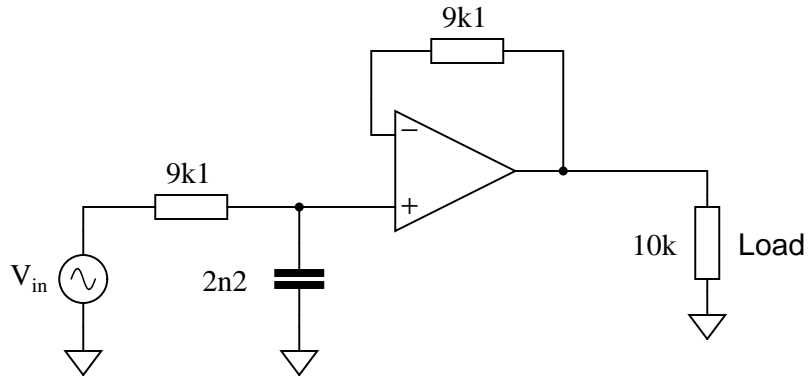

[file 02476](#)

---

Question 31

Determine the type (LP, HP, BP, BS) and cutoff frequency of this active filter circuit:

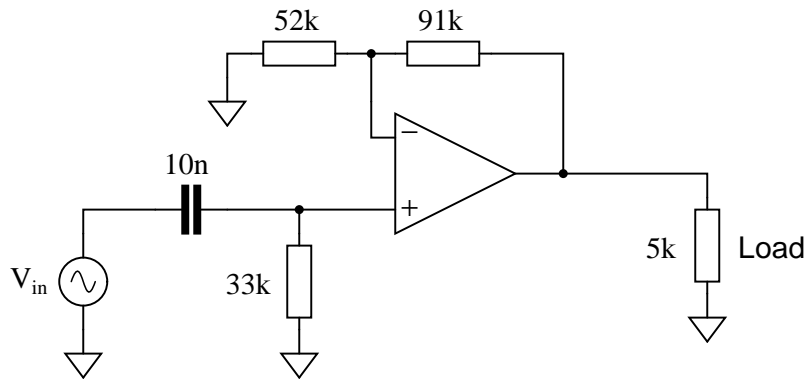

[file 02475](#)



---

Question 32

Real filters never exhibit perfect "square-edge" Bode plot responses. A typical low-pass filter circuit, for example, might have a frequency response that looks like this:

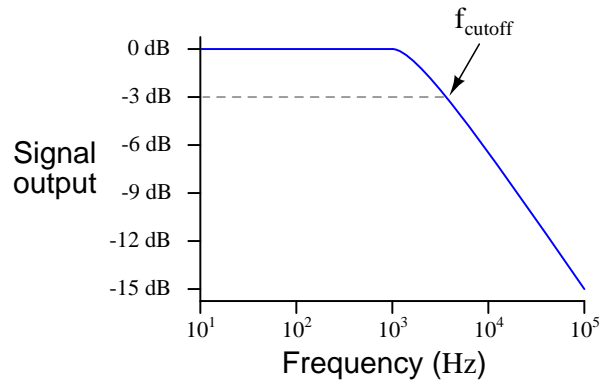

What does the term *rolloff* refer to, in the context of filter circuits and Bode plots? Why would this parameter be important to a technician or engineer?

[file 01246](#)

---

Question 33

Compare the voltage gains of these two opamp circuits:

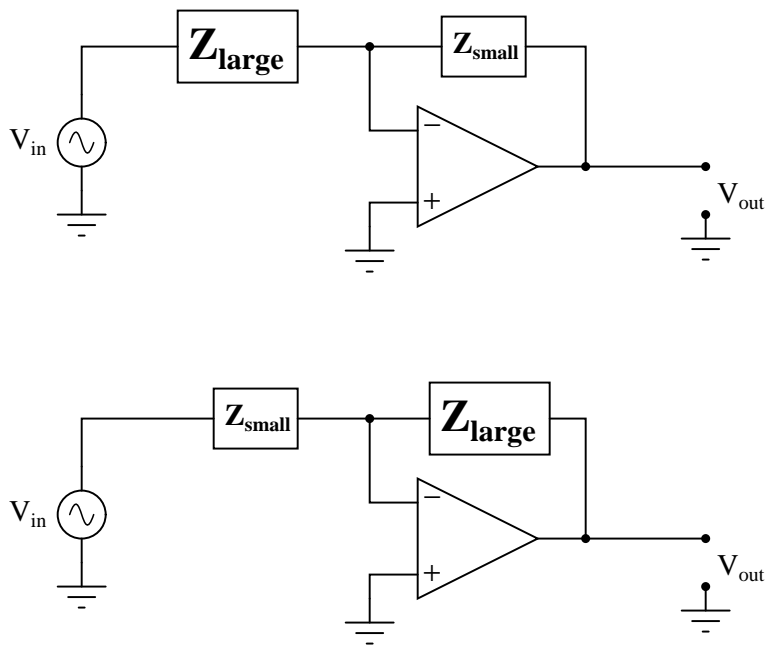

Which one has the greater  $A_V$ , and why?

[file 00700](#)

---

Question 34

Describe what will happen to the impedance of both the capacitor and the resistor as the input signal frequency increases:

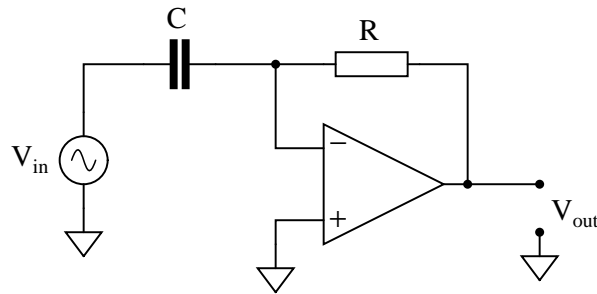

Also, describe what result the change in impedances will have on the op-amp circuit's voltage gain. If the input signal amplitude remains constant as frequency increases, what will happen to the amplitude of the output voltage? What type of filtering function does this behavior represent?

[file 00704](#)

---

Question 35

Describe what will happen to the impedance of both the capacitor and the resistor as the input signal frequency increases:

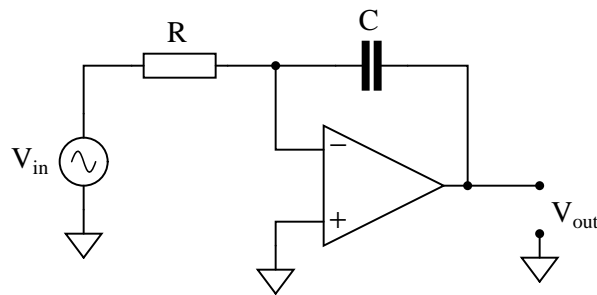

Also, describe what result the change in impedances will have on the op-amp circuit's voltage gain. If the input signal amplitude remains constant as frequency increases, what will happen to the amplitude of the output voltage? What type of filtering function does this behavior represent?

[file 00710](#)

---

Question 36

Approximate the voltage gains of this *active filter* circuit at  $f = 0$  and  $f = \infty$  (assume ideal op-amp behavior):

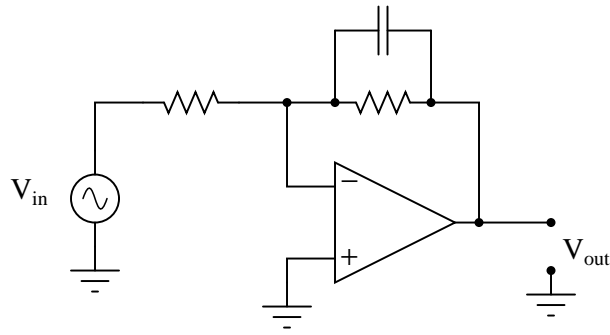

Approximate the voltage gains of this other "active filter" circuit at  $f = 0$  and  $f = \infty$  (assume ideal op-amp behavior):

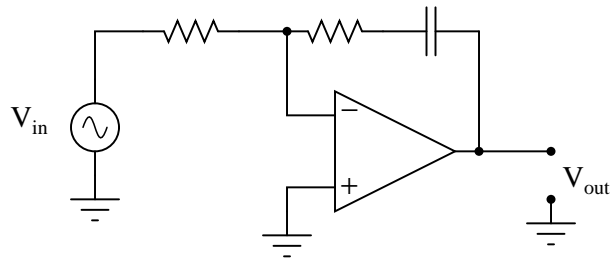

What type of filtering function (low pass, high pass, band pass, band stop) is provided by both these filter circuits? Comparing these two circuit designs, which one do you think is more practical? Explain your answer.

file 00706

---

Question 37

Approximate the voltage gains of this *active filter* circuit at  $f = 0$  and  $f = \infty$  (assume ideal op-amp behavior):

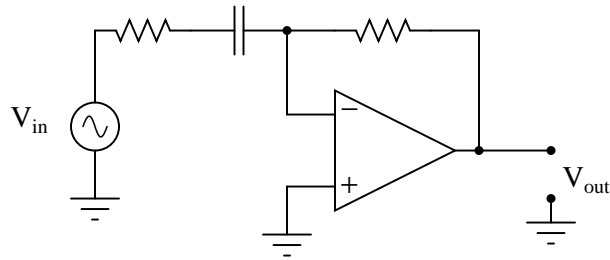

Approximate the voltage gains of this other "active filter" circuit at  $f = 0$  and  $f = \infty$  (assume ideal op-amp behavior):

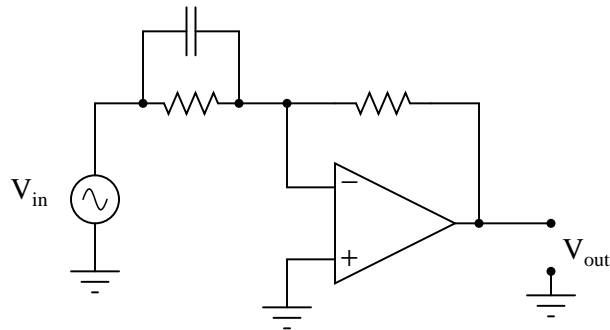

What type of filtering function (low pass, high pass, band pass, band stop) is provided by both these filter circuits? Comparing these two circuit designs, which one do you think is more practical? Explain your answer.

[file 00707](#)

---

Question 38

Identify the function of this active filter:

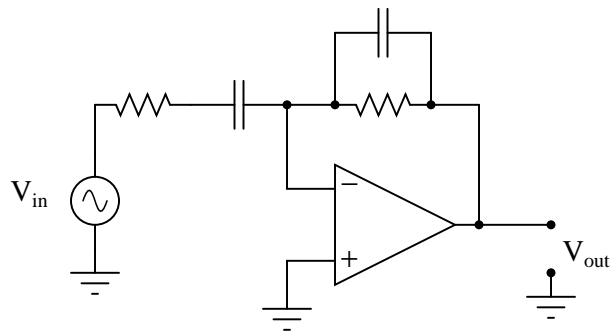

It is low pass, high pass, band pass, or band stop? Explain your answer.

[file 00708](#)

---

Question 39

Identify the function of this active filter:

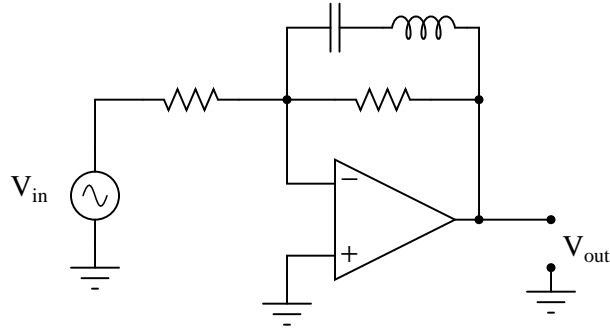

It is low pass, high pass, band pass, or band stop? Explain your answer.  
[file 00709](#)

---

Question 40

A very popular active filter topology is called the *Sallen-Key*. Two examples of Sallen-Key active filter circuits are shown here:

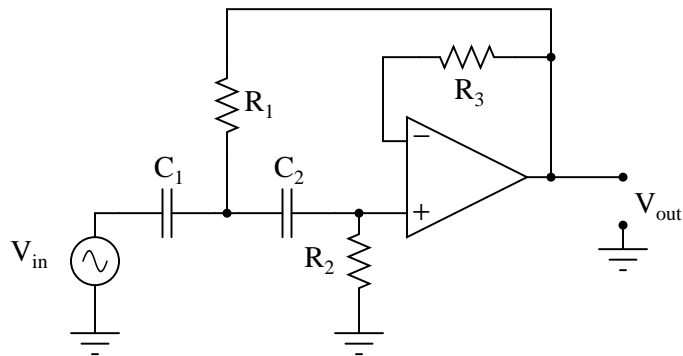
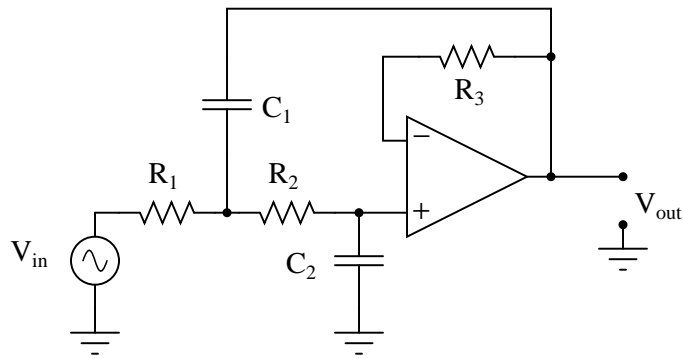

Determine which of these Sallen-Key filters is low pass, and which is high pass. Explain your answers.  
[file 00765](#)

---

Question 41

In active and passive filter design literature, you often come across filter circuits classified as one of three different names:

- Chebyshev
- Butterworth
- Bessel

Describe what each of these names means. What, exactly, distinguishes a "Chebyshev" filter circuit from a "Butterworth" filter circuit?

[file 00766](#)

---

Question 42

Choose appropriate values for this Sallen-Key high-pass filter circuit to give it a cutoff frequency of 7 kHz with a "Butterworth" response:

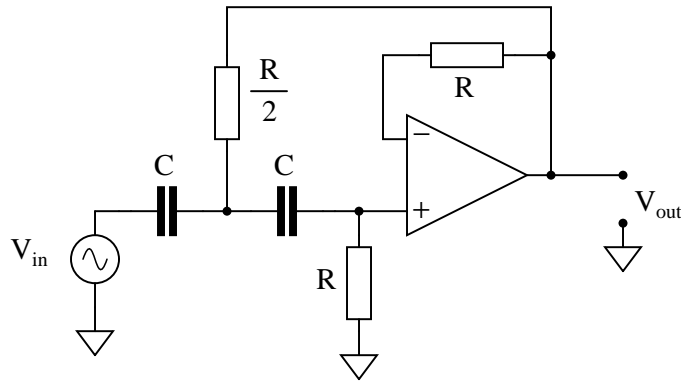

$$f_{-3dB} = \frac{\sqrt{2}}{2\pi RC}$$

A good guideline to follow is to make sure no component impedance ( $Z_R$  or  $Z_C$ ) at the cutoff frequency is less than 1 k $\Omega$  or greater than 100 k $\Omega$ .

[file 02575](#)

Question 43

Choose appropriate values for this Sallen-Key low-pass filter circuit to give it a cutoff frequency of 4.2 kHz with a "Butterworth" response:

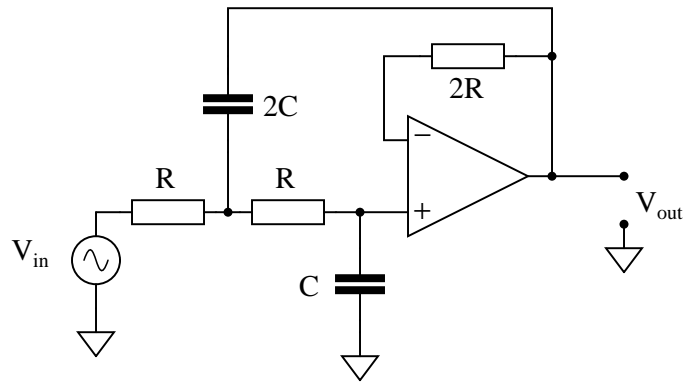

$$f_{-3dB} = \frac{1}{2\sqrt{2}\pi RC}$$

A good guideline to follow is to make sure no component impedance ( $Z_R$  or  $Z_C$ ) at the cutoff frequency is less than 1 k $\Omega$  or greater than 100 k $\Omega$ .

file 02574

Question 44

A popular passive filtering network called the *twin-tee* is often coupled with an operational amplifier to produce an active filter circuit. Two examples are shown here:

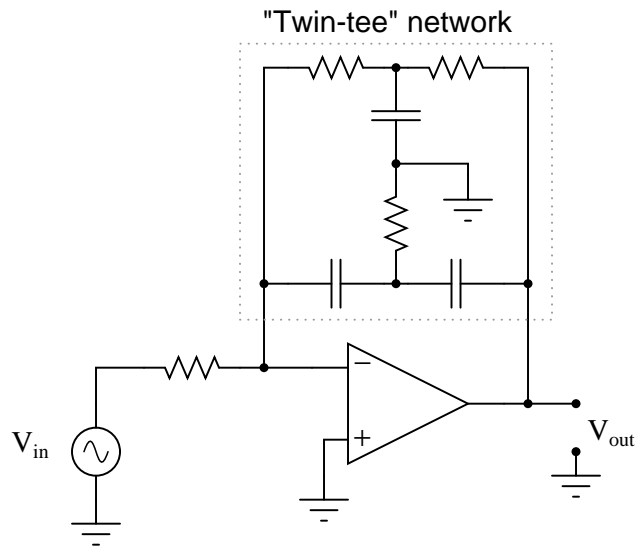
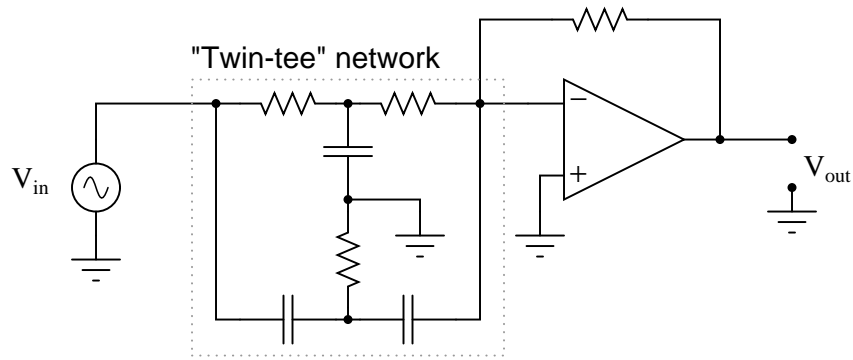

Identify which of these circuits is band-pass, and which is band-stop. Also, identify the type of response typically provided by the twin-tee network alone, and how that response is exploited to make *two* different types of active filter responses.

[file 02573](#)



Question 45

Singers who wish to practice singing to popular music find that the following *vocal eliminator* circuit is useful:

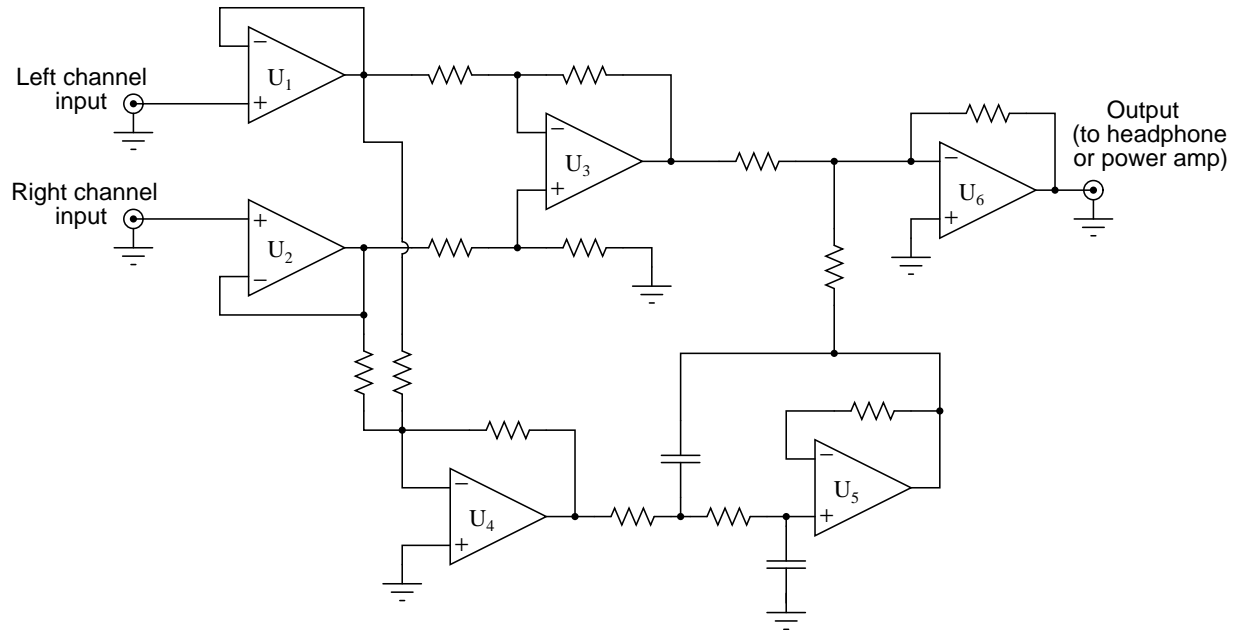

The circuit works on the principle that vocal tracks are usually recorded through a single microphone at the recording studio, and thus are represented equally on each channel of a stereo sound system. This circuit effectively eliminates the vocal track from the song, leaving only the music to be heard through the headphone or speaker.

Operational amplifiers  $U_1$  and  $U_2$  provide input buffering so that the other opamp circuits do not excessively load the left and right channel input signals. Opamp  $U_3$  performs the subtraction function necessary to eliminate the vocal track.

You might think that these three opamps would be sufficient to make a vocal eliminator circuit, but there is one more necessary feature. Not only is the vocal track common to both left and right channels, but so is most of the bass (low-frequency) tones. Thus, the first three opamps ( $U_1$ ,  $U_2$ , and  $U_3$ ) eliminate both vocal *and* bass signals from getting to the output, which is not what we want.

Explain how the other three opamps ( $U_4$ ,  $U_5$ , and  $U_6$ ) work to restore bass tones to the output so they are not lost along with the vocal track.

[file 02576](#)

---

Question 46

What would happen to the voltage across capacitor  $C_2$  if the following steps were followed, over and over again:

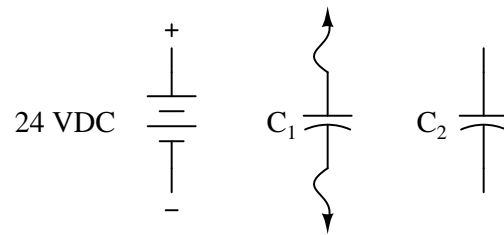

- Connect capacitor  $C_1$  to battery, allow to fully charge
- Disconnect capacitor  $C_1$  from battery
- Connect capacitor  $C_1$  to capacitor  $C_2$ , allow for charges to equalize
- Disconnect capacitor  $C_1$  from capacitor  $C_2$
- Repeat

file 01456

Question 47

Describe what happens to  $V_{out}$  (the voltage across capacitor  $C_4$ ) as time goes on, assuming the relay is continuously toggled by the oscillator circuit at a high frequency. Assume that the input voltage ( $V_{in}$ ) is constant over time:

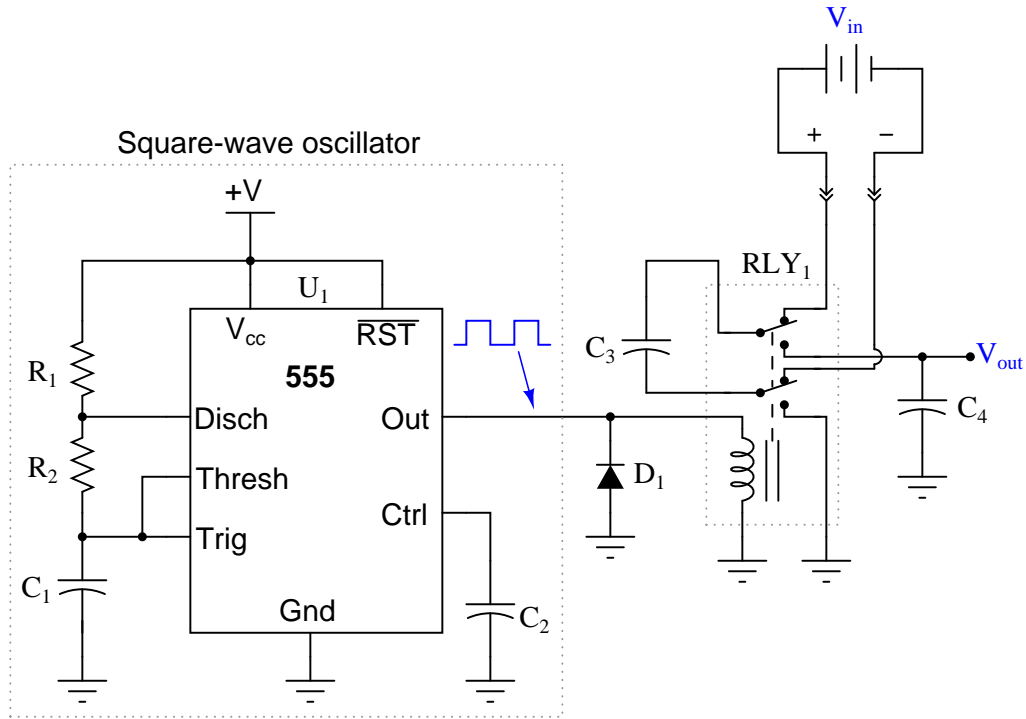

This type of circuit is often referred to as a *flying capacitor* circuit, with  $C_3$  being the "flying" capacitor. Explain why this is, and what possible benefit might be realized by using a flying capacitor circuit to sample a voltage.

[file 01455](#)

---

Question 48

Suppose an engineer decided to use a *flying capacitor* circuit to sample voltage across a shunt resistor, to measure AC current from an electrical generator:

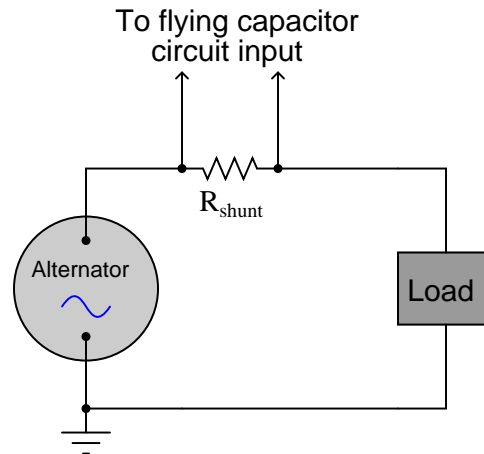

The frequency of the alternator's output is 50 Hz. How does this affect the design of the flying capacitor circuit, so we ensure a fairly accurate reproduction of the AC signal at the output of the flying capacitor circuit? Generalize your answer to cover all conditions where the input signal varies over time.

[file 01458](#)

Question 49

In this circuit, a capacitor is alternately connected to a voltage source, then a load, by means of two MOSFET transistors that are never conducting at the same time:

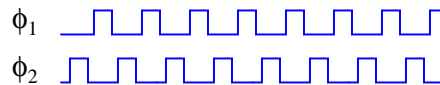
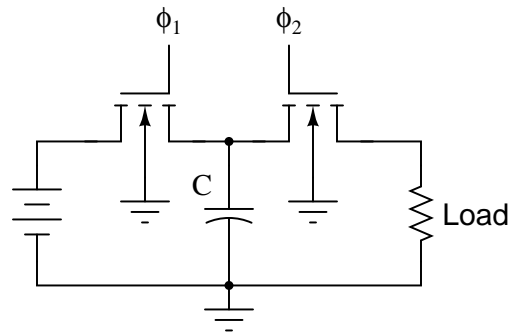

Note: the  $\phi_1$  and  $\phi_2$  pulse signals are collectively referred to as a *non-overlapping, two-phase clock*.

Consider the *average* amount of current through the load resistor, as a function of clock frequency. Assume that the "on" resistance of each MOSFET is negligible, so that the time required for the capacitor to charge is also negligible. As the clock frequency is increased, does the load resistor receive more or less average current over a span of several clock cycles? Here is another way to think about it: as the clock frequency increases, does the load resistor dissipate more or less power?

Now suppose we have a simple two-resistor circuit, where a potentiometer (connected as a variable resistor) throttles electrical current to a load:

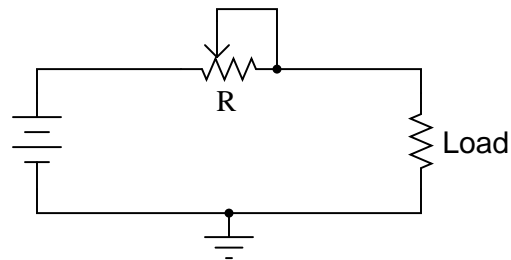

It should be obvious in this circuit that the load current decreases as variable resistance  $R$  increases. What might not be so obvious is that the aforementioned switched capacitor circuit *emulates* the variable resistor  $R$  in the second circuit, so that there is a mathematical equivalence between  $f$  and  $C$  in the first circuit, and  $R$  in the second circuit, so far as average current is concerned. To put this in simpler terms, the switched capacitor network behaves sort of like a variable resistor.

Calculus is required to prove this mathematical equivalence, but only a qualitative understanding of the two circuits is necessary to choose the correct equivalency from the following equations. Which one properly describes the equivalence of the switched capacitor network in the first circuit to the variable resistor in the second circuit?

$$R = \frac{f}{C} \quad R = \frac{C}{f} \quad R = \frac{1}{fC} \quad R = fC$$

Be sure to explain the reasoning behind your choice of equations.

[file 01459](#)

Question 50

In this circuit, a capacitor is alternately connected in series between a voltage source and a load, then shorted, by means of two MOSFET transistors that are never conducting at the same time:

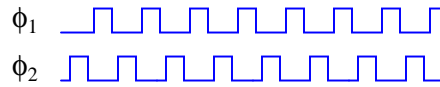
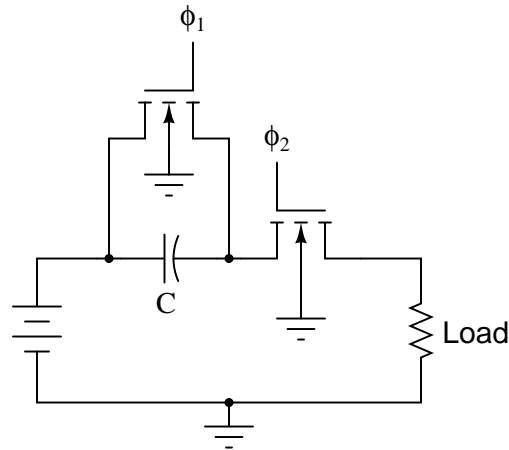

Note: the  $\phi_1$  and  $\phi_2$  pulse signals are collectively referred to as a *non-overlapping, two-phase clock*.

Consider the *average* amount of current through the load resistor, as a function of clock frequency. Assume that the "on" resistance of each MOSFET is negligible, so that the time required for the capacitor to charge is also negligible. As the clock frequency is increased, does the load resistor receive more or less average current over a span of several clock cycles? Here is another way to think about it: as the clock frequency increases, does the load resistor dissipate more or less power?

Now suppose we have a simple two-resistor circuit, where a potentiometer (connected as a variable resistor) throttles electrical current to a load:

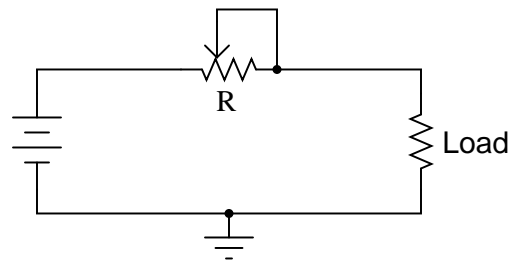

It should be obvious in this circuit that the load current decreases as variable resistance  $R$  increases. What might not be so obvious is that the aforementioned switched capacitor circuit *emulates* the variable resistor  $R$  in the second circuit, so that there is a mathematical equivalence between  $f$  and  $C$  in the first circuit, and  $R$  in the second circuit, so far as average current is concerned. To put this in simpler terms, the switched capacitor network behaves sort of like a variable resistor.

Calculus is required to prove this mathematical equivalence, but only a qualitative understanding of the two circuits is necessary to choose the correct equivalency from the following equations. Which one properly describes the equivalence of the switched capacitor network in the first circuit to the variable resistor in the second circuit?

$$R = \frac{f}{C} \quad R = \frac{C}{f} \quad R = \frac{1}{fC} \quad R = fC$$

Be sure to explain the reasoning behind your choice of equations.

[file 01460](#)

Question 51

Identify the polarity of voltage across the load resistor in the following switched capacitor circuit (called a *transresistor* circuit). Note:  $\phi_1$  and  $\phi_2$  are two-phase, non-overlapping clock signals, and the switches are just generic representations of transistors.

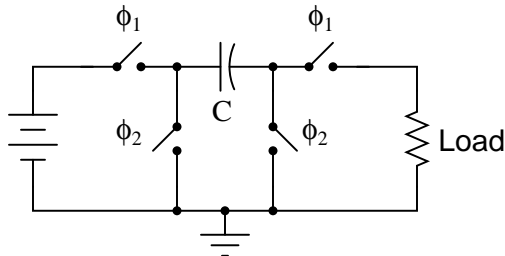

Identify the polarity of voltage across the load resistor in the following switched capacitor circuit. Note: the only difference between this circuit and the last is the switching sequence.

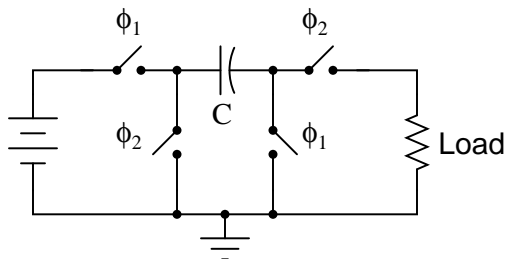

What difference would it make to the output signal of this operational amplifier circuit if the switching sequence of the switched capacitor network were changed? What difference would it make if the switching frequency were changed?

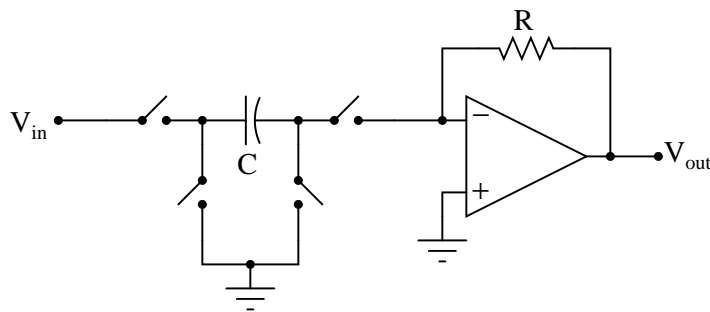

[file 01463](#)

Question 52

Research the resistance equivalence equations for each of these switched-capacitor networks (using N-channel MOSFETs as switches), describing the emulated resistance ( $R$ ) as a function of switching frequency ( $f$ ) and capacitance ( $C$ ):

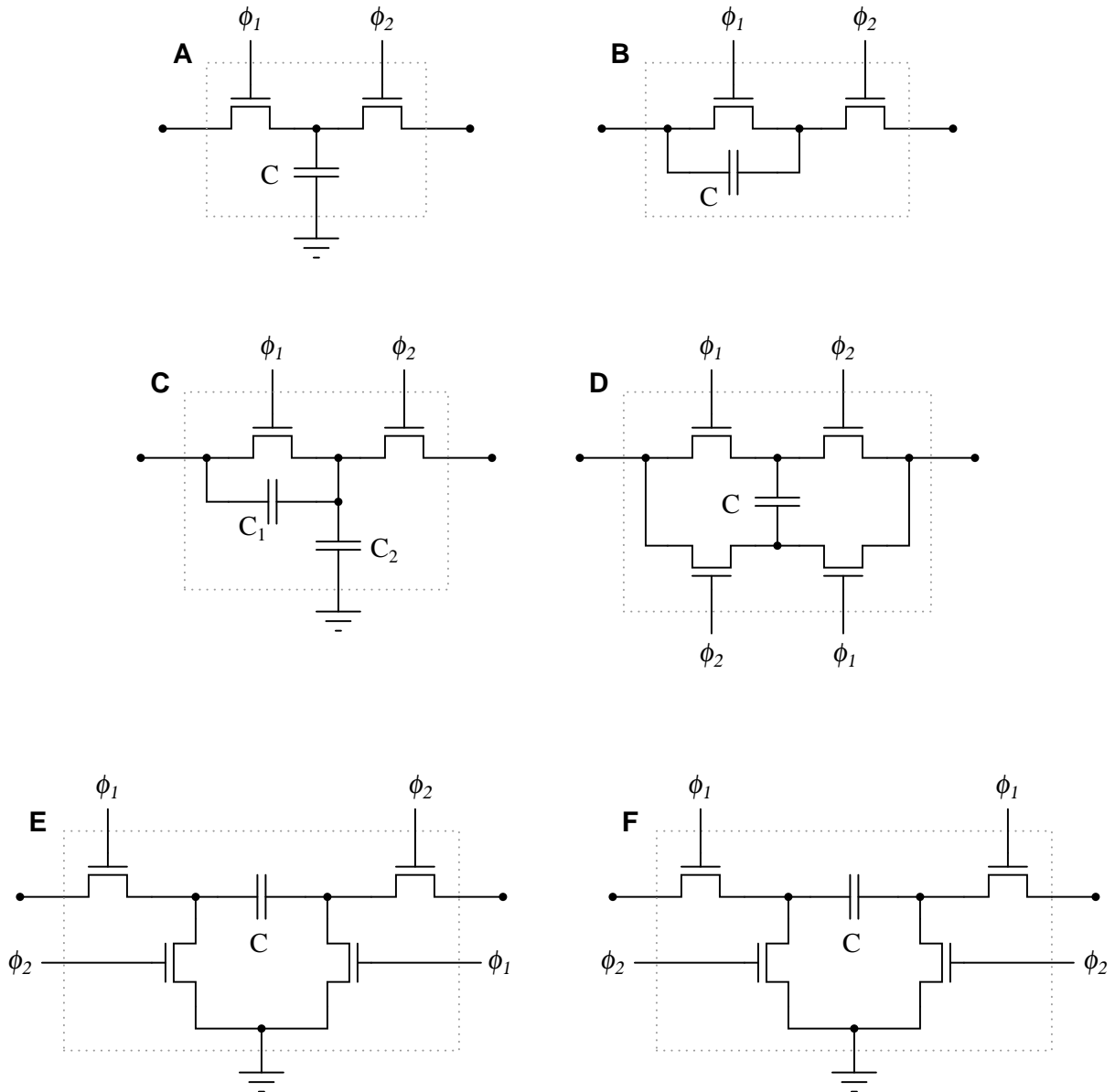

Note:  $\phi_1$  and  $\phi_2$  are two-phase, non-overlapping clock signals.

[file 03789](#)



---

Question 53

Given the fact that a switched-capacitor network has the ability to emulate a variable resistance, what advantage(s) can you think of for using switched-capacitor networks inside of analog integrated circuits? Identify some practical applications of this technology.

[file 03788](#)

---

Question 54

Identify what type of passive filter circuit this is, and then sketch a schematic diagram for an equivalent circuit using a switched-capacitor network instead of a resistor:

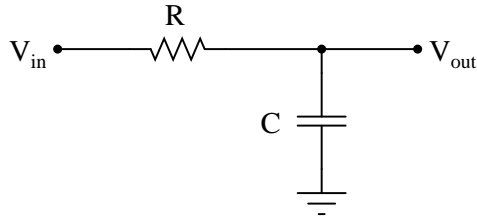

Also, write an equation describing the cutoff frequency in terms of switching frequency and capacitor values.

[file 03790](#)

---

Question 55

Identify what type of passive filter circuit this is, and then sketch a schematic diagram for an equivalent circuit using a switched-capacitor network instead of a resistor:

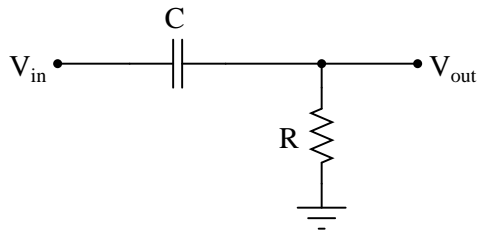

Also, write an equation describing the cutoff frequency in terms of switching frequency and capacitor values.

[file 03791](#)

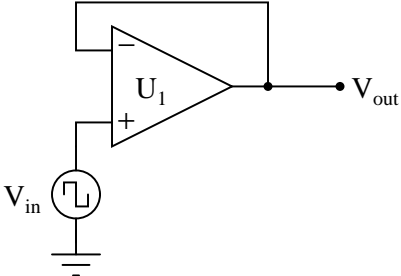
Competency: <b>Opamp slew rate</b>	Version:				
<b>Schematic</b>					
					
<b>Given conditions</b>					
+V =	$V_{in} =$				
-V =	f =				
<b>Instructions</b>					
<p>Adjust input signal amplitude and frequency until the opamp is no longer able to follow it, and the output resembles a triangle waveform. The slope of the triangle wave will be the slew rate.</p>					
<b>Parameters</b>					
$+\frac{dv}{dt}$ (max.)	<table border="1" style="display: inline-table; border-collapse: collapse;"> <thead> <tr> <th style="padding: 5px;">Measured</th> <th style="padding: 5px;">Advertised</th> </tr> </thead> <tbody> <tr> <td style="width: 60px; height: 20px;"></td> <td style="width: 60px; height: 20px;"></td> </tr> </tbody> </table>	Measured	Advertised		
Measured	Advertised				
$-\frac{dv}{dt}$ (max.)	<table border="1" style="display: inline-table; border-collapse: collapse;"> <thead> <tr> <th style="padding: 5px;">Measured</th> <th style="padding: 5px;">Advertised</th> </tr> </thead> <tbody> <tr> <td style="width: 60px; height: 20px;"></td> <td style="width: 60px; height: 20px;"></td> </tr> </tbody> </table>	Measured	Advertised		
Measured	Advertised				

[file 02567](#)

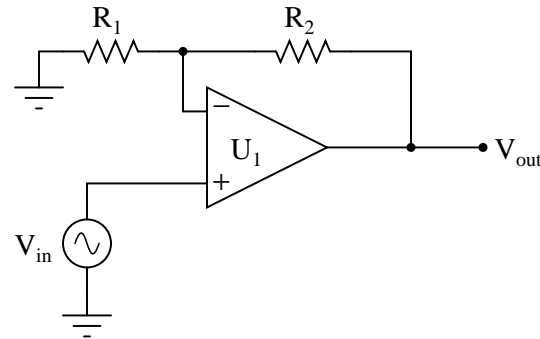
Competency: <b>Opamp gain-bandwidth product</b>	Version:																														
<b>Schematic</b>																															
																															
<b>Given conditions</b>																															
+V =	Unity-gain frequency of opamp =																														
-V =																															
<b>Instructions</b>																															
<div style="border: 1px solid black; padding: 5px; display: inline-block;"> <math>f = f_{-3dB} \text{ when } V_{out} = \frac{V_{out(max)}}{\sqrt{2}}</math> </div>																															
<p>Keep <math>V_{in}</math> low enough that <math>V_{out}</math> remains sinusoidal (undistorted)</p> <p>Predict and measure <math>f_{-3dB}</math> at three different gains (<math>A_{CL}</math>)</p> <p>Calculate gain-bandwidth product (GBW) at those gains, and then average.</p>																															
<b>Parameters</b>																															
	<table style="width: 100%; border-collapse: collapse;"> <thead> <tr> <th style="width: 15%;"></th> <th style="width: 15%;">Predicted</th> <th style="width: 15%;">Measured</th> <th style="width: 15%;">@ <math>A_{CL} = (R_2 / R_1) + 1</math></th> <th style="width: 15%;">GBW</th> <th style="width: 15%;">Calculated</th> </tr> </thead> <tbody> <tr> <td><math>f_{-3dB}</math></td> <td><input style="width: 80%;" type="text"/></td> <td><input style="width: 80%;" type="text"/></td> <td><input style="width: 80%;" type="text"/></td> <td><input style="width: 80%;" type="text"/></td> <td><input style="width: 80%;" type="text"/></td> </tr> <tr> <td><math>f_{-3dB}</math></td> <td><input style="width: 80%;" type="text"/></td> <td><input style="width: 80%;" type="text"/></td> <td><input style="width: 80%;" type="text"/></td> <td><input style="width: 80%;" type="text"/></td> <td><input style="width: 80%;" type="text"/></td> </tr> <tr> <td><math>f_{-3dB}</math></td> <td><input style="width: 80%;" type="text"/></td> <td><input style="width: 80%;" type="text"/></td> <td><input style="width: 80%;" type="text"/></td> <td><input style="width: 80%;" type="text"/></td> <td><input style="width: 80%;" type="text"/></td> </tr> <tr> <td></td> <td></td> <td></td> <td></td> <td></td> <td style="text-align: center;"> <b>GBW<sub>average</sub></b> <input style="width: 80%;" type="text"/> </td> </tr> </tbody> </table>		Predicted	Measured	@ $A_{CL} = (R_2 / R_1) + 1$	GBW	Calculated	$f_{-3dB}$	<input style="width: 80%;" type="text"/>	<input style="width: 80%;" type="text"/>	<input style="width: 80%;" type="text"/>	<input style="width: 80%;" type="text"/>	<input style="width: 80%;" type="text"/>	$f_{-3dB}$	<input style="width: 80%;" type="text"/>	<input style="width: 80%;" type="text"/>	<input style="width: 80%;" type="text"/>	<input style="width: 80%;" type="text"/>	<input style="width: 80%;" type="text"/>	$f_{-3dB}$	<input style="width: 80%;" type="text"/>	<input style="width: 80%;" type="text"/>	<input style="width: 80%;" type="text"/>	<input style="width: 80%;" type="text"/>	<input style="width: 80%;" type="text"/>						<b>GBW<sub>average</sub></b> <input style="width: 80%;" type="text"/>
	Predicted	Measured	@ $A_{CL} = (R_2 / R_1) + 1$	GBW	Calculated																										
$f_{-3dB}$	<input style="width: 80%;" type="text"/>	<input style="width: 80%;" type="text"/>	<input style="width: 80%;" type="text"/>	<input style="width: 80%;" type="text"/>	<input style="width: 80%;" type="text"/>																										
$f_{-3dB}$	<input style="width: 80%;" type="text"/>	<input style="width: 80%;" type="text"/>	<input style="width: 80%;" type="text"/>	<input style="width: 80%;" type="text"/>	<input style="width: 80%;" type="text"/>																										
$f_{-3dB}$	<input style="width: 80%;" type="text"/>	<input style="width: 80%;" type="text"/>	<input style="width: 80%;" type="text"/>	<input style="width: 80%;" type="text"/>	<input style="width: 80%;" type="text"/>																										
					<b>GBW<sub>average</sub></b> <input style="width: 80%;" type="text"/>																										

file 02360

Competency: <b>Sallen-Key active lowpass filter</b>	Version:					
<b>Schematic</b>						
<b>Given conditions</b>						
$+V =$	$R_1 =$	$C_1 =$				
$-V =$	$R_2 =$	$C_2 =$				
	$R_{comp} =$					
<b>Parameters</b>						
$f_{-3dB}$	<table border="1" style="margin: auto;"> <thead> <tr> <th style="padding: 5px;">Predicted</th> <th style="padding: 5px;">Measured</th> </tr> </thead> <tbody> <tr> <td style="width: 60px; height: 25px;"></td> <td style="width: 60px; height: 25px;"></td> </tr> </tbody> </table>	Predicted	Measured			
Predicted	Measured					
<b>Fault analysis</b>						
Suppose component <input style="width: 40px; height: 20px;" type="text"/> fails <input type="checkbox"/> open <input type="checkbox"/> other _____ <input type="checkbox"/> shorted <i>What will happen in the circuit?</i>						

file 02577

Competency: <b>Sallen-Key active highpass filter</b>	Version:	
<b>Schematic</b>		
<b>Given conditions</b>		
$+V =$	$R_1 =$	$C_1 =$
$-V =$	$R_2 =$	$C_2 =$
	$R_{comp} =$	
<b>Parameters</b>		
	Predicted	Measured
$f_{-3dB}$	<input style="width: 80px; height: 25px;" type="text"/>	<input style="width: 80px; height: 25px;" type="text"/>
<b>Fault analysis</b>		
Suppose component <input style="width: 50px; height: 25px;" type="text"/> fails		<input type="checkbox"/> open <input type="checkbox"/> other _____ <input type="checkbox"/> shorted
<i>What will happen in the circuit?</i>		

file 02578

Competency: <b>Twin-T active bandpass filter</b>	Version:			
<b>Schematic</b>				
<b>Given conditions</b>				
$+V =$	$R_1 =$	$R_3 =$	$C_1 =$	$C_3 =$
$-V =$	$R_2 =$	$R_4 =$	$C_2 =$	
<b>Parameters</b>				
$f_{\text{center}}$	Predicted	Measured		
	<input style="width: 100px; height: 20px;" type="text"/>	<input style="width: 100px; height: 20px;" type="text"/>		

file 02588

---

Question 61

NAME: \_\_\_\_\_

**Project Grading Criteria**

PROJECT: \_\_\_\_\_

You will receive the highest score for which *all* criteria are met.

100 % (*Must meet or exceed all criteria listed*)

- A. Impeccable craftsmanship, comparable to that of a professional assembly
- B. No spelling or grammatical errors anywhere in *any* document, upon first submission to instructor

95 % (*Must meet or exceed these criteria in addition to all criteria for 90% and below*)

- A. Technical explanation sufficiently detailed to teach from, inclusive of every component (supersedes 75.B)
- B. Itemized parts list complete with part numbers, manufacturers, and (equivalent) prices for *all* components, including recycled components and parts kit components (supersedes 90.A)

90 % (*Must meet or exceed these criteria in addition to all criteria for 85% and below*)

- A. Itemized parts list complete with prices of components purchased for the project, plus total price
- B. No spelling or grammatical errors anywhere in *any* document upon final submission

85 % (*Must meet or exceed these criteria in addition to all criteria for 80% and below*)

- A. “User’s guide” to project function (in addition to 75.B)
- B. Troubleshooting log describing all obstacles overcome during development and construction

80 % (*Must meet or exceed these criteria in addition to all criteria for 75% and below*)

- A. All controls (switches, knobs, etc.) clearly and neatly labeled
- B. All documentation created on computer, not hand-written (including the schematic diagram)

75 % (*Must meet or exceed these criteria in addition to all criteria for 70% and below*)

- A. Stranded wire used wherever wires are subject to vibration or bending
- B. Basic technical explanation of all major circuit sections
- C. Deadline met for working prototype of circuit (Date/Time = \_\_\_\_\_ / \_\_\_\_\_ )

70 % (*Must meet or exceed these criteria in addition to all criteria for 65%*)

- A. All wire connections sound (solder joints, wire-wrap, terminal strips, and lugs are all connected properly)
- B. No use of glue where a fastener would be more appropriate
- C. Deadline met for submission of fully-functional project (Date/Time = \_\_\_\_\_ / \_\_\_\_\_ ) – supersedes 75.C if final project submitted by that (earlier) deadline

65 % (*Must meet or exceed these criteria in addition to all criteria for 60%*)

- A. Project fully functional
- B. All components securely fastened so nothing is “loose” inside the enclosure
- C. Schematic diagram of circuit

60 % (*Must meet or exceed these criteria in addition to being safe and legal*)

- A. Project minimally functional, with all components located inside an enclosure (if applicable)
- B. Passes final safety inspection (proper case grounding, line power fusing, power cords strain-relieved)

0 % (*If any of the following conditions are true*)

- A. Fails final safety inspection (improper grounding, fusing, and/or power cord strain relieving)
- B. Intended project function poses a safety hazard
- C. Project function violates any law, ordinance, or school policy

file 03173

---

Question 62

Suppose a few turns of wire within the inductor in this filter circuit suddenly became short-circuited, so that the inductor effectively has fewer turns of wire than it did before:

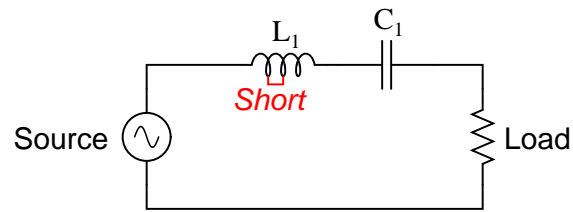

What sort of effect would this fault have on the filtering action of this circuit?

[file 03505](#)

---

Question 63

Controlling electrical "noise" in automotive electrical systems can be problematic, as there are many sources of "noise" voltages throughout a car. Spark ignitions and alternators can both generate substantial noise voltages, superimposed on the DC voltage in a car's electrical system. A simple way to electrically model this noise is to draw it as an AC "noise voltage" source in series with the DC source. If this noise enters a radio or audio amplifier, the result will be an irritating sound produced at the speakers:

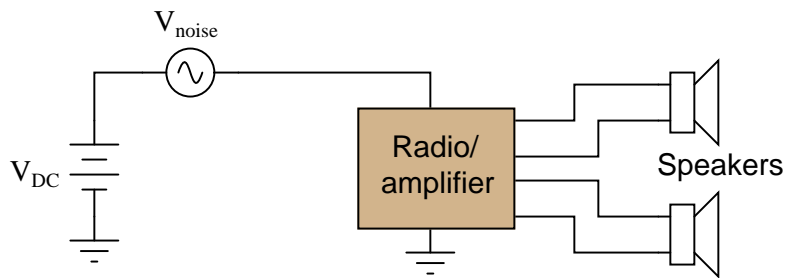

What would you suggest as a "fix" for this problem if a friend asked you to apply your electronics expertise to their noisy car audio system? Be sure to provide at least two practical suggestions.

[file 03510](#)



---

Question 64

Predict how the operation of this second-order passive filter circuit will be affected as a result of the following faults. Consider each fault independently (i.e. one at a time, no multiple faults):

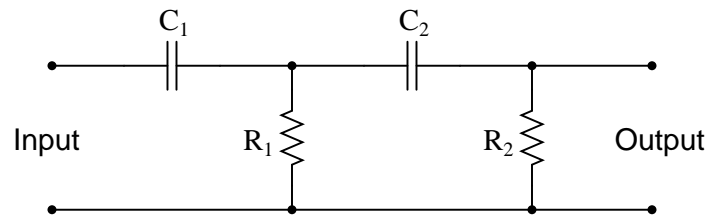

- Capacitor  $C_1$  fails open:
- Capacitor  $C_2$  fails shorted:
- Resistor  $R_1$  fails open:
- Resistor  $R_2$  fails open:
- Solder bridge (short) across resistor  $R_2$ :

For each of these conditions, explain *why* the resulting effects will occur.

[file 03792](#)

---

Question 65

Predict how the operation of this active filter circuit will be affected as a result of the following faults. Consider each fault independently (i.e. one at a time, no multiple faults):

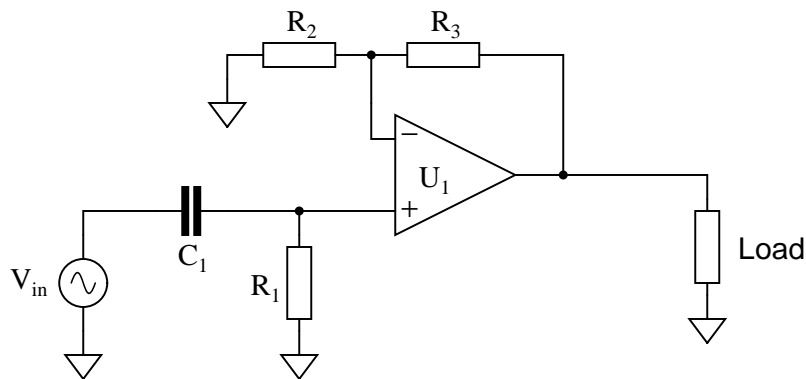

- Resistor  $R_1$  fails open:
- Capacitor  $C_1$  fails open:
- Solder bridge (short) across resistor  $R_1$ :
- Solder bridge (short) across capacitor  $C_1$ :
- Resistor  $R_2$  fails open:
- Resistor  $R_3$  fails open:

For each of these conditions, explain *why* the resulting effects will occur.

[file 03786](#)

---

Question 66

Predict how the operation of this active filter circuit will be affected as a result of the following faults. Consider each fault independently (i.e. one at a time, no multiple faults):

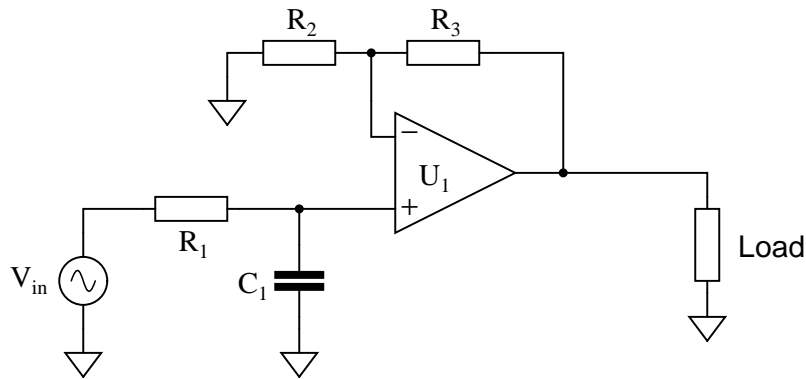

- Resistor  $R_1$  fails open:
- Capacitor  $C_1$  fails open:
- Solder bridge (short) across resistor  $R_1$ :
- Solder bridge (short) across capacitor  $C_1$ :
- Resistor  $R_2$  fails open:
- Resistor  $R_3$  fails open:

For each of these conditions, explain *why* the resulting effects will occur.  
[file 03787](#)

---

Question 67

Predict how the operation of this active differentiator circuit will be affected as a result of the following faults. Consider each fault independently (i.e. one at a time, no multiple faults):

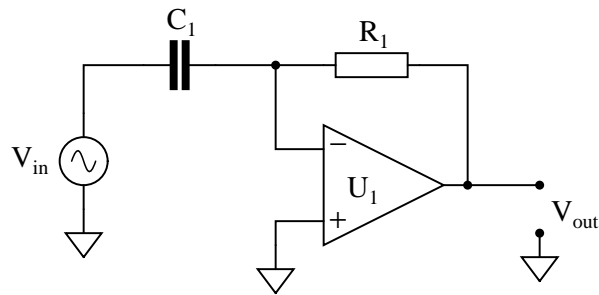

- Resistor  $R_1$  fails open:
- Capacitor  $C_1$  fails open:
- Solder bridge (short) across resistor  $R_1$ :
- Solder bridge (short) across capacitor  $C_1$ :

For each of these conditions, explain *why* the resulting effects will occur.  
[file 03793](#)

---

Question 68

Predict how the operation of this active filter circuit will be affected as a result of the following faults. Consider each fault independently (i.e. one at a time, no multiple faults):

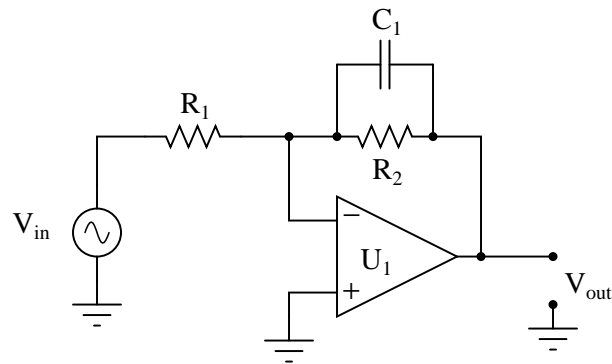

- Resistor  $R_1$  fails open:
- Resistor  $R_2$  fails open:
- Capacitor  $C_1$  fails open:
- Solder bridge (short) across resistor  $R_1$ :
- Solder bridge (short) across resistor  $R_2$ :
- Solder bridge (short) across capacitor  $C_1$ :

For each of these conditions, explain *why* the resulting effects will occur.

file 03794

---

Question 69

Predict how the operation of this active filter circuit will be affected as a result of the following faults. Consider each fault independently (i.e. one at a time, no multiple faults):

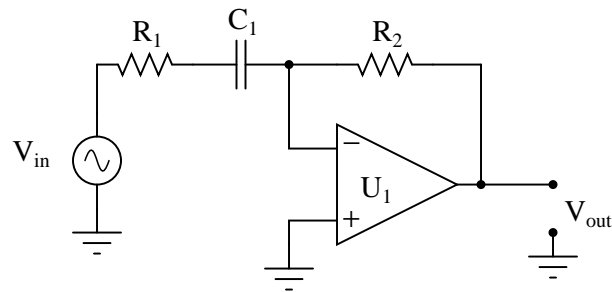

- Resistor  $R_1$  fails open:
- Resistor  $R_2$  fails open:
- Capacitor  $C_1$  fails open:
- Solder bridge (short) across resistor  $R_1$ :
- Solder bridge (short) across resistor  $R_2$ :
- Solder bridge (short) across capacitor  $C_1$ :

For each of these conditions, explain *why* the resulting effects will occur.  
[file 03795](#)

Question 70

This vocal eliminator circuit used to work just fine, but then one day it seemed to lose a lot of its bass. It still did its job of eliminating the vocal track, but instead of hearing the full range of musical tones it only reproduced the high frequencies, while the low frequency tones were lost:

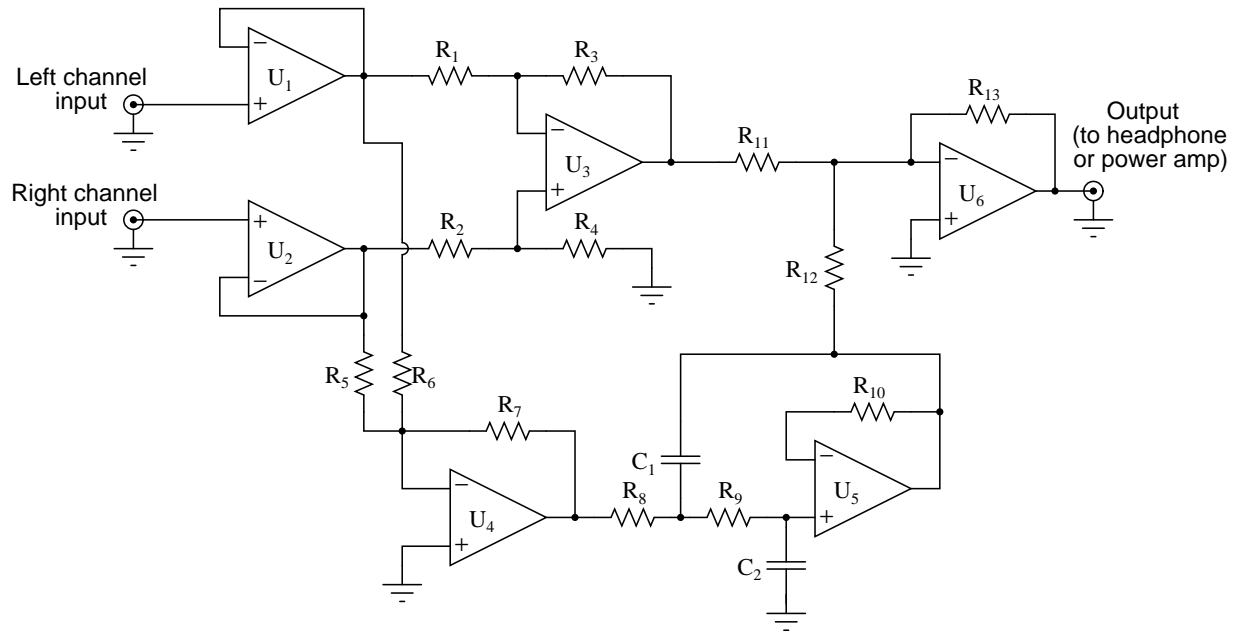

Identify the following fault possibilities:

One resistor failure (either open or shorted) that could cause this to happen:

One capacitor failure (either open or shorted) that could cause this to happen:

One opamp failure that could cause this to happen:

For each of these proposed faults, explain *why* the bass tones would be lost.  
[file 03796](#)

Question 71

This vocal eliminator circuit used to work just fine, but then one day it stopped eliminating the vocal track. The tone of the music sounded a bit heavy on the bass, and the vocal track was there when it shouldn't have been there:

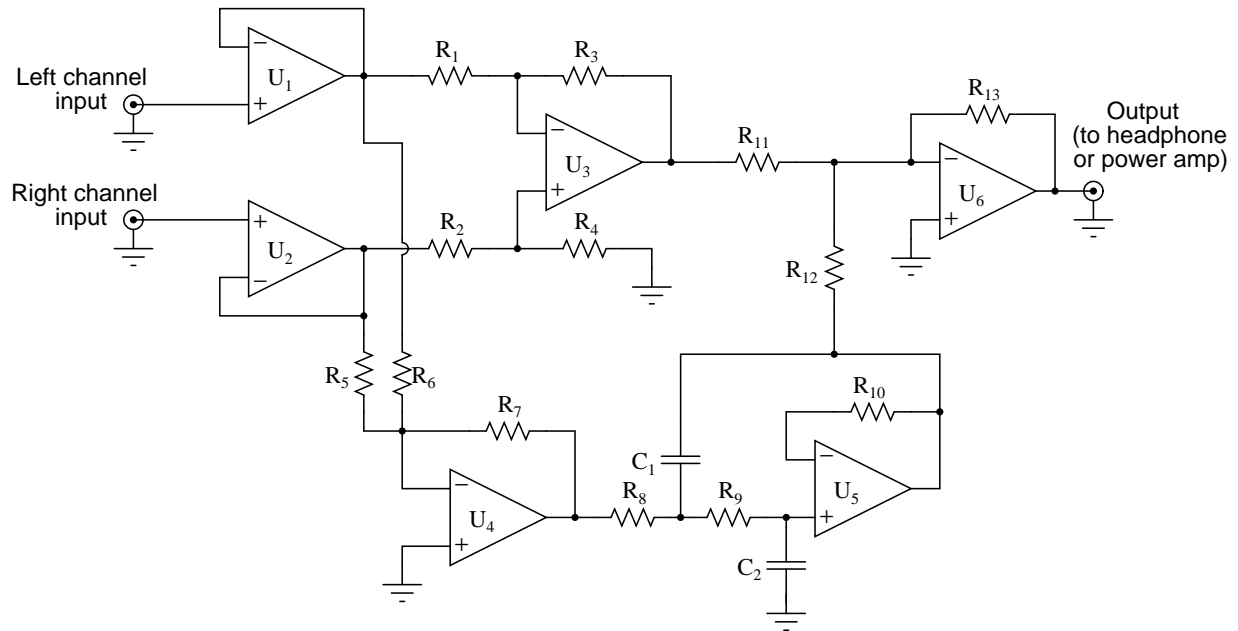

Identify the following fault possibilities:

One resistor failure (either open or shorted) that could cause this to happen:

One opamp failure that could cause this to happen:

For each of these proposed faults, explain *why* the bass tones would be lost.

file 03797

Question 72

It strikes some students as odd that opamps would have a constant slew rate. That is, when subjected to a step-change input voltage, an opamp's output voltage would quickly ramp *linearly* over time, rather than ramp in some other way (such as the inverse exponential curve seen in RC and RL pulse circuits):

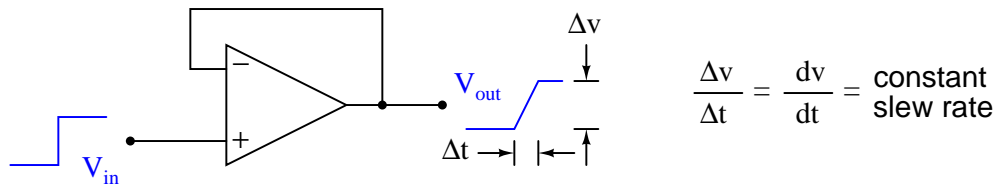

Yet, this effect has a definite cause, and it is found in the design of the opamp's internal circuitry: the voltage multiplication stages within operational amplifier circuits often use *active loading* for increased voltage gain. An example of active loading may be seen in the following schematic diagram for the classic 741 opamp, where transistor  $Q_9$  acts as an active load for transistor  $Q_{10}$ , and where transistor  $Q_{13}$  provides an active load for transistor  $Q_{17}$ :

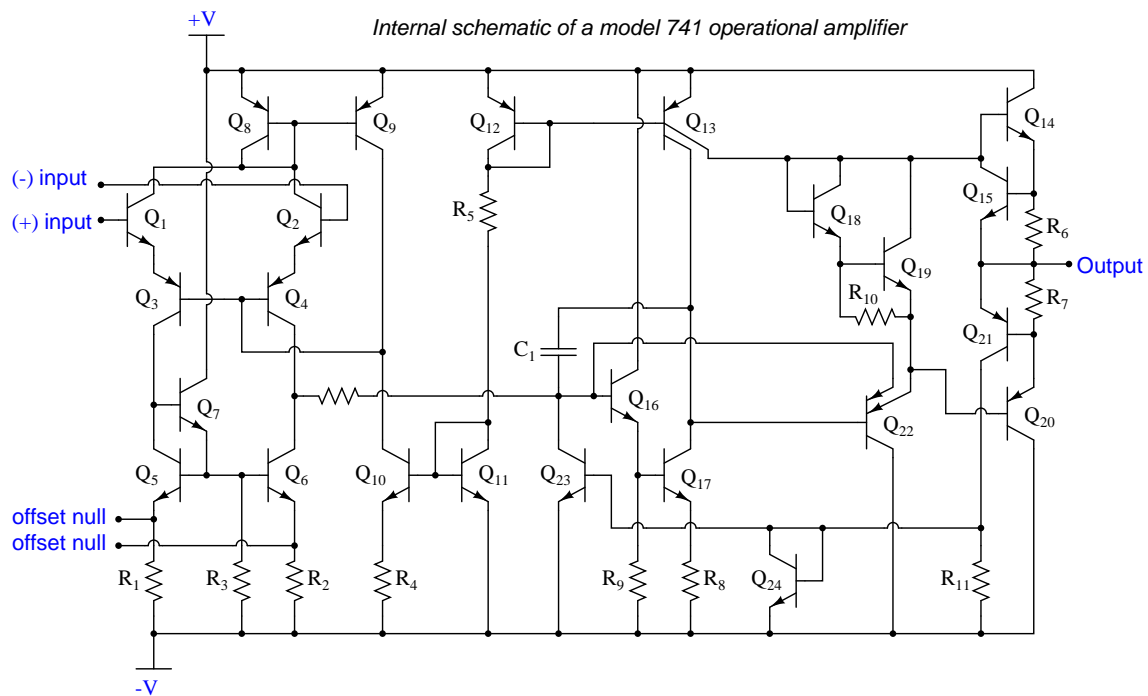

Explain how active loading creates the constant slew rate exhibited by operational amplifier circuits such as the 741. What factors account for the *linear* ramping of voltage over time?

file 02603

---

Question 73

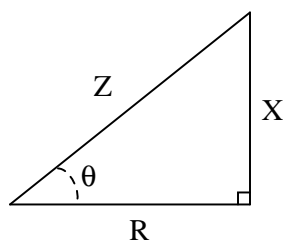

Identify which trigonometric functions (sine, cosine, or tangent) are represented by each of the following ratios, with reference to the angle labeled with the Greek letter "Theta" ( $\Theta$ ):

$$\frac{X}{R} =$$

$$\frac{X}{Z} =$$

$$\frac{R}{Z} =$$

[file 02084](#)

---

Question 74

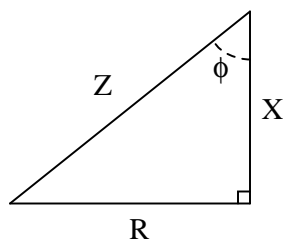

Identify which trigonometric functions (sine, cosine, or tangent) are represented by each of the following ratios, with reference to the angle labeled with the Greek letter "Phi" ( $\phi$ ):

$$\frac{R}{X} =$$

$$\frac{X}{Z} =$$

$$\frac{R}{Z} =$$

[file 03113](#)



---

Question 75

The *impedance triangle* is often used to graphically relate  $Z$ ,  $R$ , and  $X$  in a series circuit:

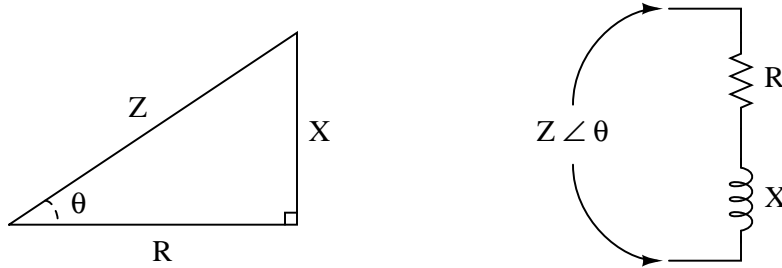

Unfortunately, many students do not grasp the significance of this triangle, but rather memorize it as a "trick" used to calculate one of the three variables given the other two. Explain *why* a right triangle is an appropriate form to relate these variables, and what each side of the triangle actually represents.

[file 02076](#)

---

Question 76

Explain why the "impedance triangle" is *not* proper to use for relating total impedance, resistance, and reactance in parallel circuits as it is for series circuits:

*This impedance triangle does **not** apply to parallel circuits, but only to series circuits!*

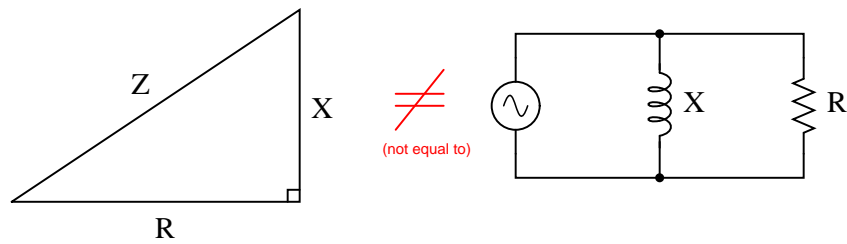

[file 02078](#)

---

Question 77

Examine the following circuits, then label the sides of their respective triangles with all the variables that are trigonometrically related in those circuits:

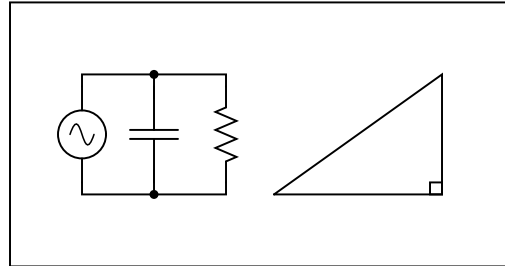
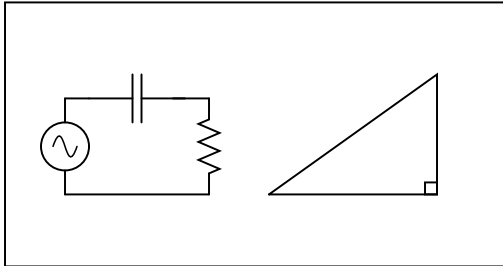
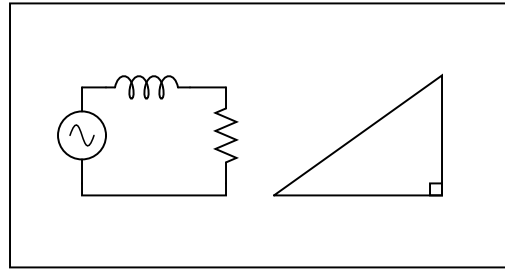
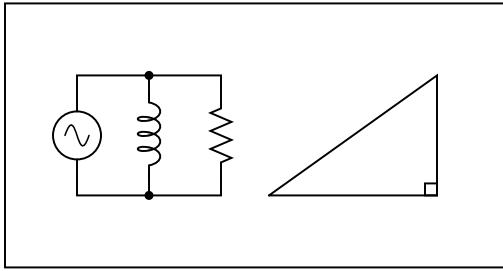

[file 03288](#)

---

Question 78

Use the "impedance triangle" to calculate the necessary reactance of this series combination of resistance ( $R$ ) and inductive reactance ( $X$ ) to produce the desired total impedance of  $145 \Omega$ :

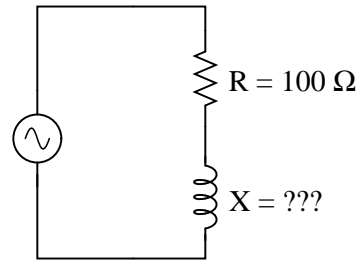
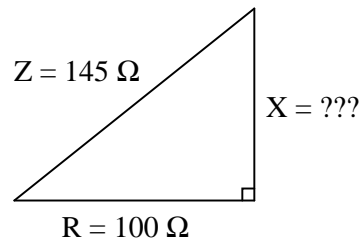

Explain what equation(s) you use to calculate  $X$ , and the algebra necessary to achieve this result from a more common formula.

[file 02083](#)

---

Question 79

A series AC circuit exhibits a total impedance of  $10\text{ k}\Omega$ , with a phase shift of  $65$  degrees between voltage and current. Drawn in an impedance triangle, it looks like this:

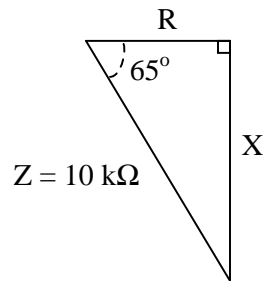

We know that the *sine* function relates the sides  $X$  and  $Z$  of this impedance triangle with the  $65$  degree angle, because the sine of an angle is the ratio of *opposite* to *hypotenuse*, with  $X$  being opposite the  $65$  degree angle. Therefore, we know we can set up the following equation relating these quantities together:

$$\sin 65^\circ = \frac{X}{Z}$$

Solve this equation for the value of  $X$ , in ohms.

[file 02088](#)

---

Question 80

A series AC circuit exhibits a total impedance of  $2.5\text{ k}\Omega$ , with a phase shift of  $30$  degrees between voltage and current. Drawn in an impedance triangle, it looks like this:

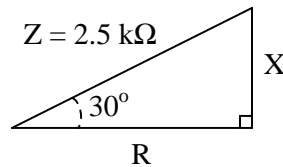

Use the appropriate trigonometric functions to calculate the equivalent values of  $R$  and  $X$  in this series circuit.

[file 02087](#)

---

Question 81

A parallel AC circuit draws 8 amps of current through a purely resistive branch and 14 amps of current through a purely inductive branch:

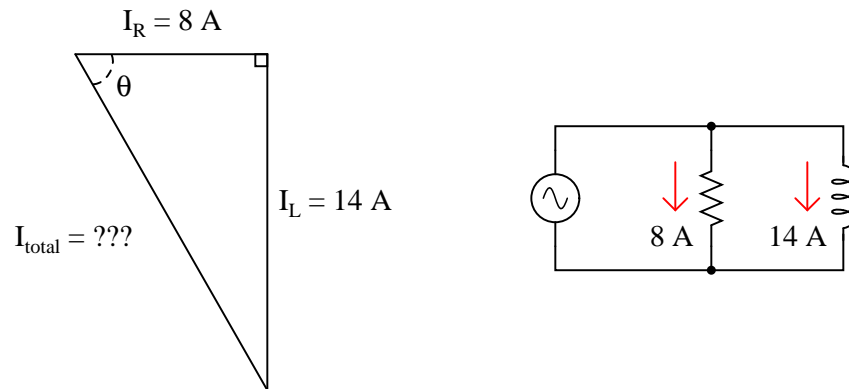

Calculate the total current and the angle  $\theta$  of the total current, explaining your trigonometric method(s) of solution.

[file 02089](#)

---

Question 82

A parallel RC circuit has  $10 \mu\text{S}$  of susceptance ( $B$ ). How much conductance ( $G$ ) is necessary to give the circuit a (total) phase angle of 22 degrees?

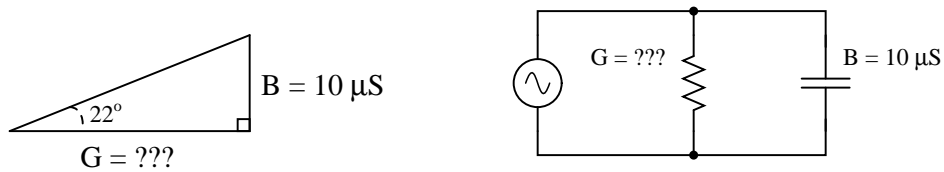

[file 02090](#)

---

Question 83

Calculate the impedance (in complex number form) "seen" by the AC signal source as it drives the passive integrator circuit on the left, and the active integrator circuit on the right. In both cases, assume that nothing is connected to the  $V_{out}$  terminal:

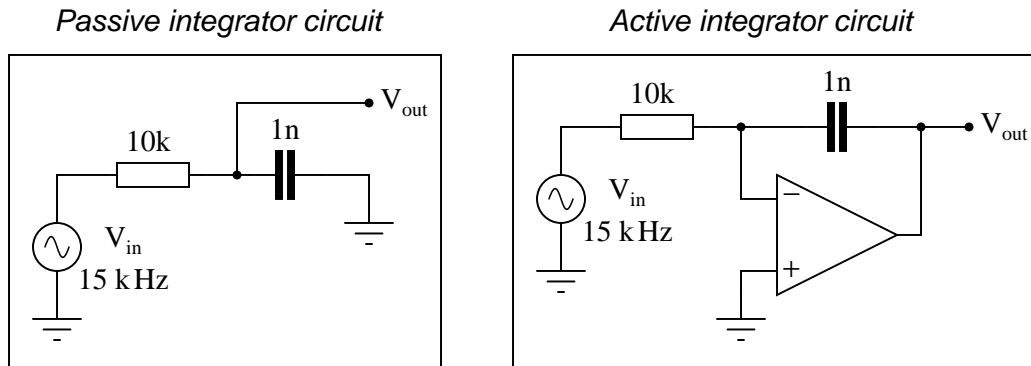

[file 02563](#)

---

Question 84

Calculate the phase angle of the current drawn from the AC signal source as it drives the passive integrator circuit on the left, and the active integrator circuit on the right. In both cases, assume that nothing is connected to the  $V_{out}$  terminal:

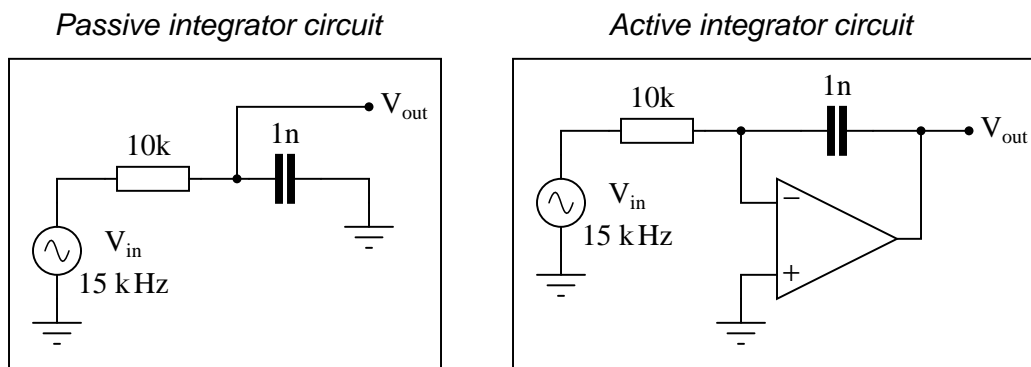

[file 02564](#)

---

Question 85

Draw the Bode plot for an *ideal* high-pass filter circuit:

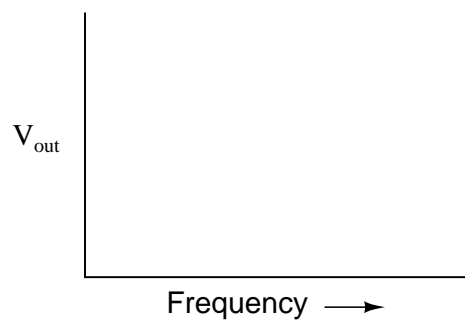

Be sure to note the "cutoff frequency" on your plot.

file 00618

---

Question 86

Draw the Bode plot for an *ideal* low-pass filter circuit:

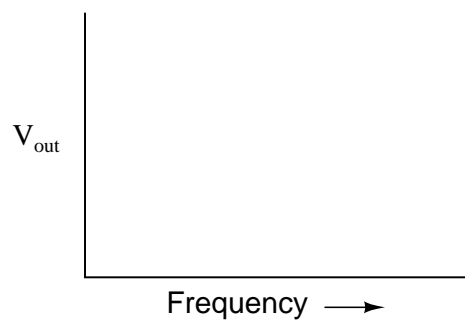

Be sure to note the "cutoff frequency" on your plot.

file 01245

---

Question 87

Suppose you were installing a high-power stereo system in your car, and you wanted to build a simple filter for the "tweeter" (high-frequency) speakers so that no bass (low-frequency) power is wasted in these speakers. Modify the schematic diagram below with a filter circuit of your choice:

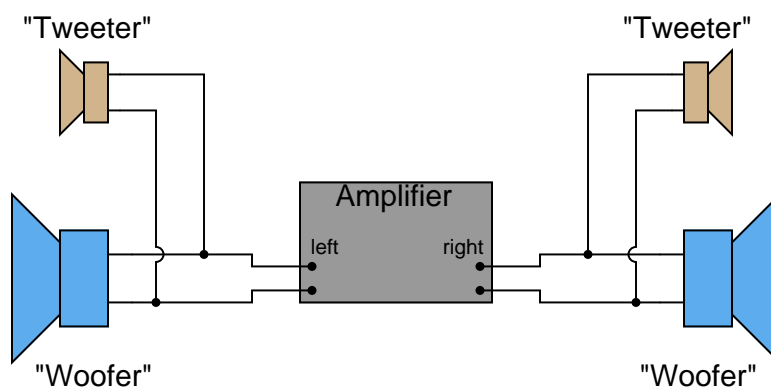

Hint: this only requires a single component per tweeter!  
[file 00613](#)

Question 88

The *superposition principle* describes how AC signals of different frequencies may be "mixed" together and later separated in a linear network, without one signal distorting another. DC may also be similarly mixed with AC, with the same results.

This phenomenon is frequently exploited in computer networks, where DC power and AC data signals (on-and-off pulses of voltage representing 1-and-0 binary bits) may be combined on the same pair of wires, and later separated by filter circuits, so that the DC power goes to energize a circuit, and the AC signals go to another circuit where they are interpreted as digital data:

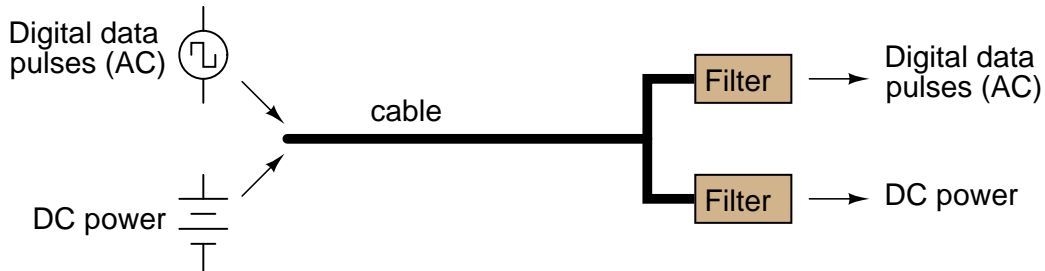

Filter circuits are also necessary on the transmission end of the cable, to prevent the AC signals from being shunted by the DC power supply's capacitors, and to prevent the DC voltage from damaging the sensitive circuitry generating the AC voltage pulses.

Draw some filter circuits on each end of this two-wire cable that perform these tasks, of separating the two sources from each other, and also separating the two signals (DC and AC) from each other at the receiving end so they may be directed to different loads:

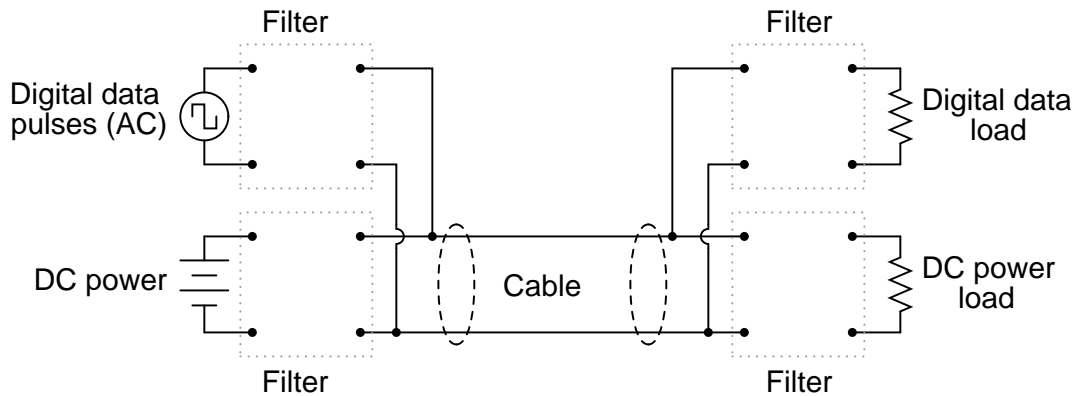

[file 00612](#)



---

Question 89

Identify what type of filter this circuit is, and calculate the size of resistor necessary to give it a cutoff frequency of 3 kHz:

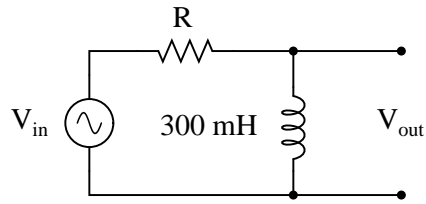

[file 00619](#)

---

Question 90

What kind of filtering action (high-pass, low-pass, band-pass, band-stop) does this resonant circuit provide?

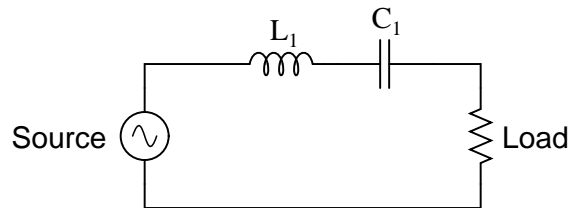

[file 01392](#)

---

Question 91

What kind of filtering action (high-pass, low-pass, band-pass, band-stop) does this resonant circuit provide?

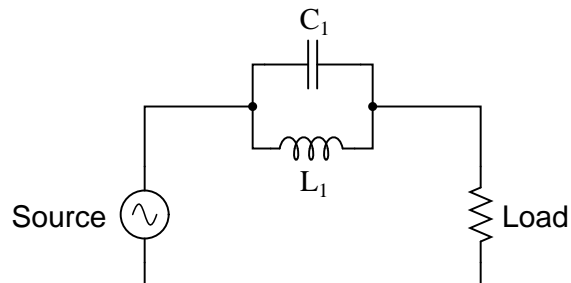

[file 02570](#)

Question 92

A *white noise* source is a special type of AC signal voltage source which outputs a broad band of frequencies ("noise") with a constant amplitude across its rated range. Determine what the display of a spectrum analyzer would show if directly connected to a white noise source, and also if connected to a low-pass filter which is in turn connected to a white noise source:

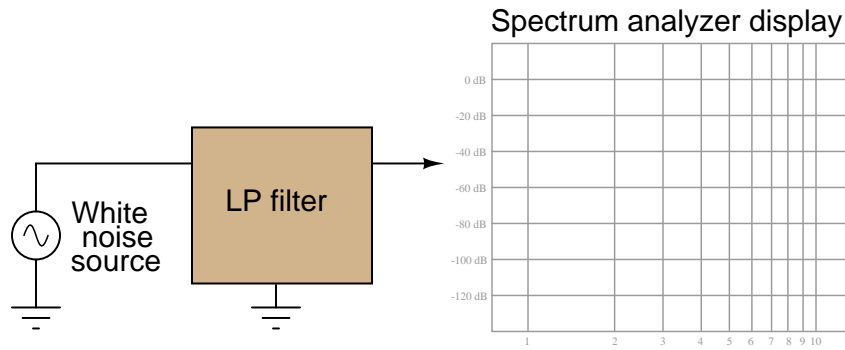
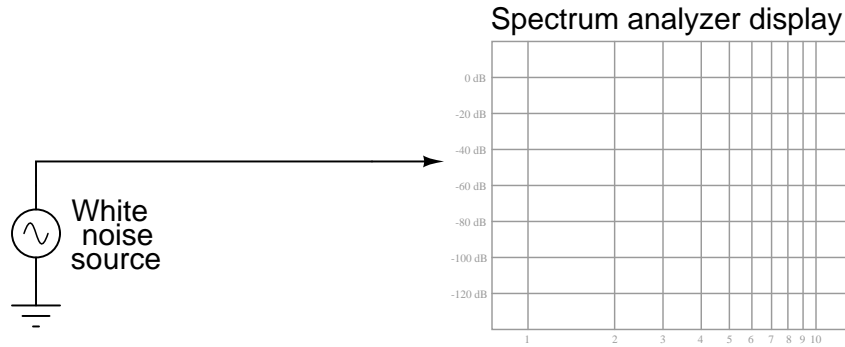

file 03621

## Answers

---

### Answer 1

The capacitance provides a path for an AC feedback signal to go from the collector to the base. Given the inverting phase relationship between collector voltage and base voltage, this feedback is degenerative.

---

### Answer 2

The amplifier with the larger collector resistance will be affected more by the feedback capacitance, because its naturally greater voltage gain produces a larger voltage signal to be fed back to the base, for any given level of input signal.

---

### Answer 3

The presence of  $C_{BC}$  in a common-emitter circuit mitigates high-frequency oscillations.

---

### Answer 4

Some op-amps are inherently unstable when operated in negative-feedback mode, and will oscillate on their own unless "phase-compensated" by an external capacitor.

Follow-up question: Are there any applications of an op-amp such as the CA3130 where a compensation capacitor is not needed, or worse yet would be an impediment to successful circuit operation? Hint: some models of op-amp (such as the model 741) have built-in compensation capacitors!

---

### Answer 5

Identifying the capacitor is easy: it is the only one in the whole circuit! It couples signal from the collector of  $Q_{17}$ , which is an active-loaded common-emitter amplifier, to the base of  $Q_{16}$ , which is an emitter-follower driving  $Q_{17}$ . Since  $Q_{17}$  inverts the signal applied to  $Q_{16}$ 's base, the feedback is degenerative.

---

### Answer 6

The difference is the physical location of the compensating capacitor, whether it is a part of the integrated circuit or external to it.

Follow-up question: show how an external compensating capacitor may be connected to an opamp such as the LM101.

---

### Answer 7

GBW product is a constant value for most operational amplifiers, equal to the open-loop gain of the opamp multiplied by the signal frequency at that gain.

---

### Answer 8

Unity-Gain Bandwidth is the frequency at which an operational amplifier's open-loop voltage gain is equal to 1.

---

### Answer 9

The greater the amount of compensation capacitance in an op-amp (either internal, or externally connected), the less the GBW product.

---

### Answer 10

*Slew rate* is the maximum rate of change of output voltage over time ( $\left. \frac{dv}{dt} \right|_{max}$ ) that an opamp can muster.

Follow-up question: what would the output waveform of an opamp look like if it were trying to amplify a square wave signal with a frequency and amplitude exceeding the amplifier's slew rate?

---

Answer 11

The resistor will drop more voltage.

$$Z_{total} \text{ (rectangular form)} = 5100 \Omega - j4671 \Omega$$

$$Z_{total} \text{ (polar form)} = 6916 \Omega \angle -42.5^\circ$$

---

Answer 12

- Capacitor as it "appears" to a low frequency signal: *high* impedance.
- Capacitor as it "appears" to a high frequency signal: *low* impedance.
  
- Inductor as it "appears" to a low frequency signal: *low* impedance.
- Inductor as it "appears" to a high frequency signal: *high* impedance.

Challenge question: what does a capacitor "appear" as to a *DC* signal?

---

Answer 13

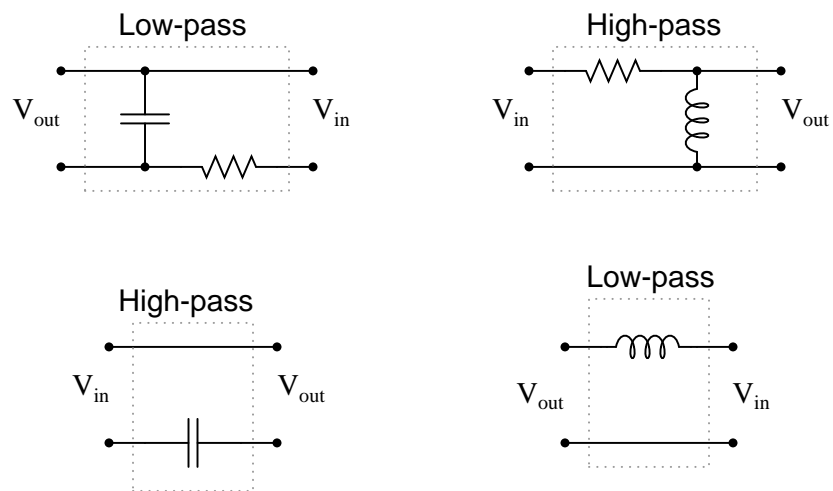

Answer 14

This is a *low-pass* filter.

$$f_{cutoff} = 723.4 \text{ Hz}$$

---

Answer 15

$$f_{cutoff} = \frac{1}{2\pi RC} \quad \text{(For simple RC filter circuits)}$$

$$f_{cutoff} = \frac{R}{2\pi L} \quad \text{(For simple LR filter circuits)}$$

---

Answer 16

The "tank circuit" filters out all the unwanted radio frequencies, so that the listener hears only one radio station broadcast at a time.

Follow-up question: how might a variable capacitor be constructed, to suit the needs of a circuit such as this? Note that the capacitance range for a tuning capacitor such as this is typically in the pico-Farad range.

---

Answer 17

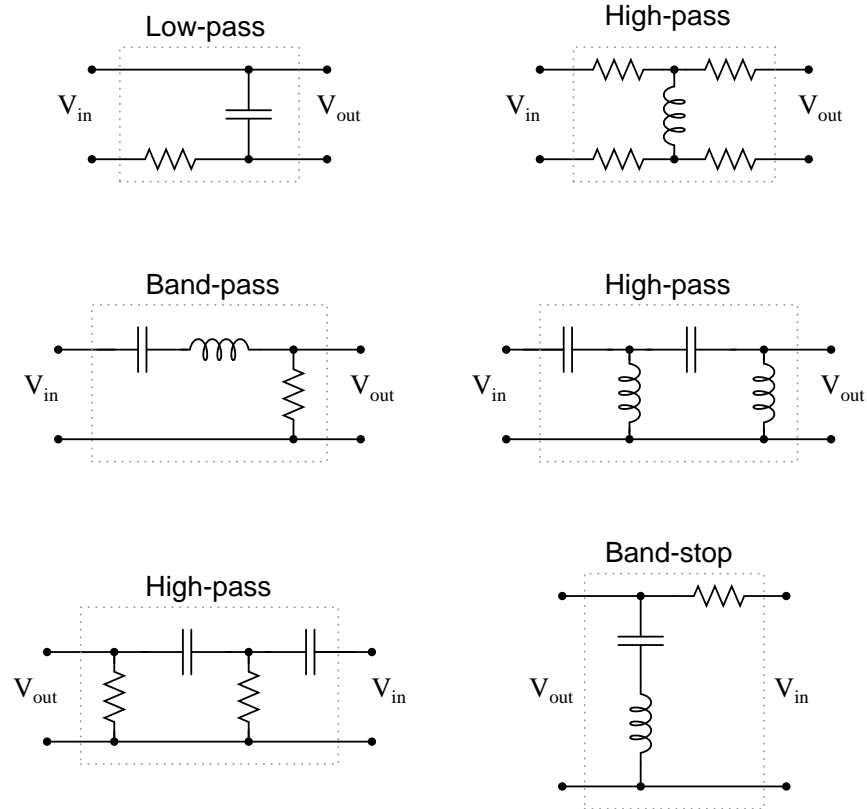

Follow-up question: in each of the circuits shown, identify at least one *single* component failure that has the ability to prevent any signal voltage from reaching the output terminals.

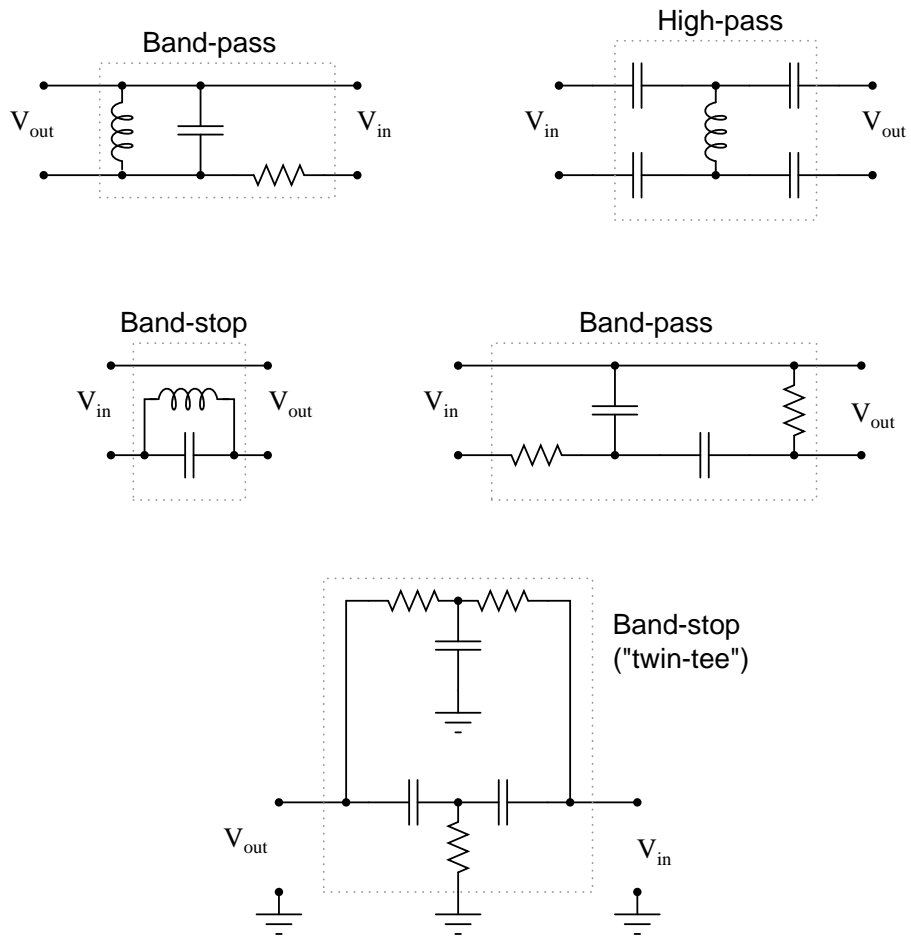

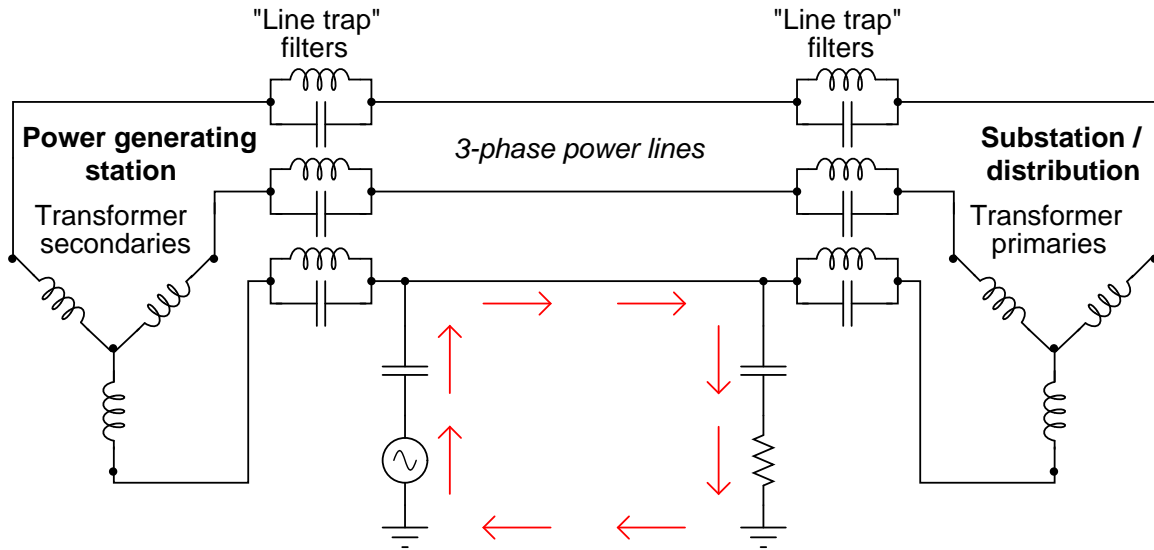

Follow-up question #1: trace the path of line-frequency (50 Hz or 60 Hz) load current in this system, identifying which component of the line trap filters ( $L$  or  $C$ ) is more important to the passage of power to the load. Remember that the line trap filters are tuned to resonate at the frequency of the communication signal (50-150 kHz is typical).

Follow-up question #2: coupling capacitor units used in power line carrier systems are special-purpose, high-voltage devices. One of the features of a standard coupling capacitor unit is a *spark gap* intended to "clamp" overvoltages arising from lightning strikes and other transient events on the power line:

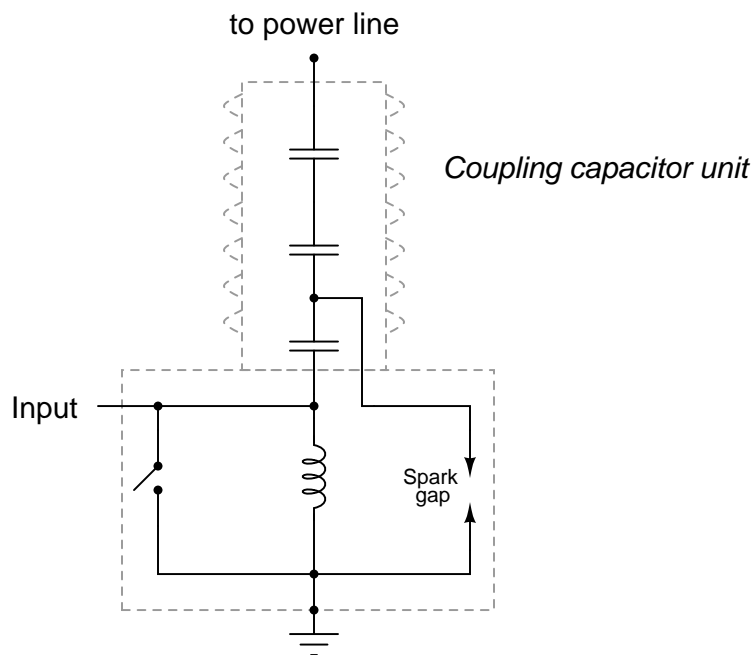

Explain how such a spark gap is supposed to work, and why it functions as an over-voltage protection device.

---

Answer 20

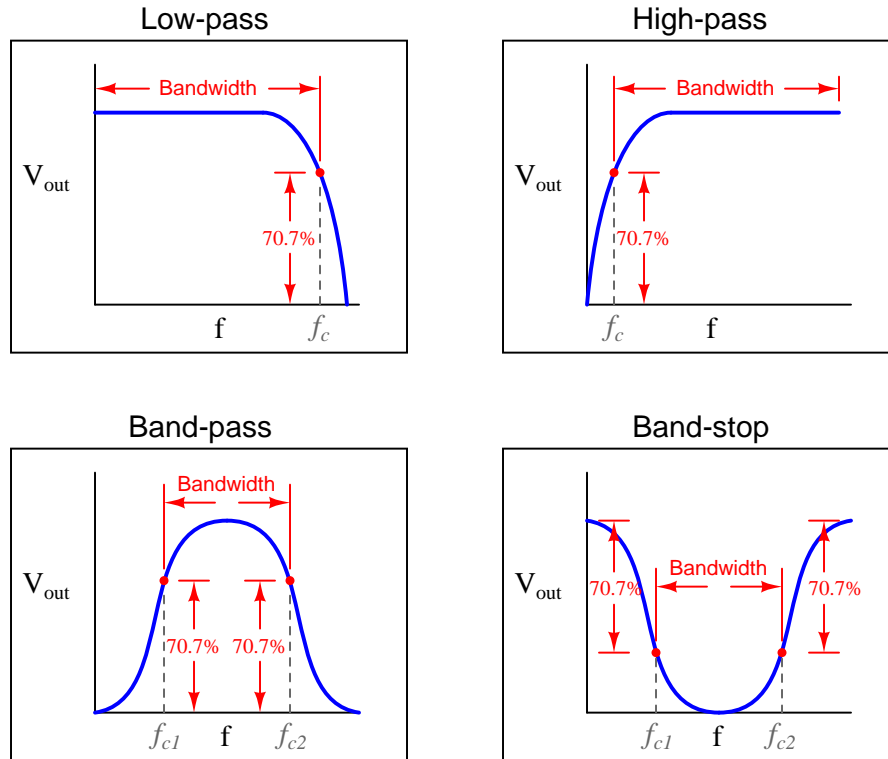

---

Answer 21

$$Q = \frac{1}{R} \sqrt{\frac{L}{C}}$$

---

Answer 22

HP filter:  $\Theta = +45^\circ$  ( $V_{out}$  leads  $V_{in}$ )

LP filter:  $\Theta = -45^\circ$  ( $V_{out}$  lags  $V_{in}$ )

---

Answer 23

$$f = 6.54 \text{ kHz}$$

---

Answer 24

$$f = 465 \text{ Hz}$$



---

Answer 25

A broken connection between the right-hand terminal of the potentiometer and the bridge could cause this to happen:

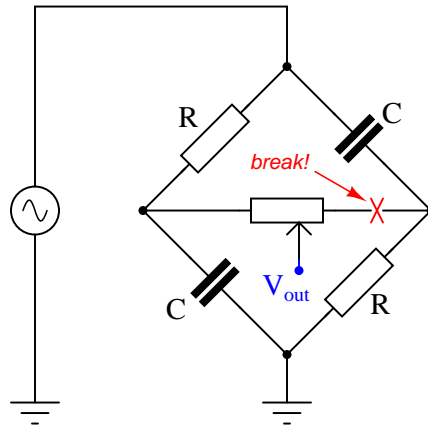

I'll let you figure out why!

---

Answer 26

This is a *high-pass* filter circuit, with a cutoff frequency of:

$$f_{-3dB} = \frac{1}{2\pi RC}$$

---

Answer 27

$f_{cutoff}$  will increase as the load resistance decreases.

---

Answer 28

$f_{cutoff}$  is unaffected by changes in load resistance.

Follow-up question: explain the opamp's role in providing immunity to the filter circuit from load resistance changes. *How* does it accomplish this feat?

---

Answer 29

This is a "trick" question:  $f_{cutoff}$  is unaffected by changes in the potentiometer's position.

Follow-up question: what *does* change as the potentiometer wiper is moved back and forth along its adjustment range?

---

Answer 30

This is a low-pass filter circuit.

$$f_{-3dB} = 7.95 \text{ kHz}$$

Follow-up question: explain what the purpose of the 9.1 k $\Omega$  feedback resistor is, since all we're using the opamp for is a voltage buffer anyway (which theoretically does not require resistance in the feedback loop). Furthermore, explain how the Superposition theorem is used to determine the optimum value of this feedback resistance.

---

Answer 31

This is a high-pass filter circuit.

$$f_{-3dB} = 482.3 \text{ Hz}$$

Follow-up question: the feedback resistor network comprised of the 52 k $\Omega$  and 91 k $\Omega$  resistors not only provides a gain of 1.75 (4.86 dB), but these values were also intentionally chosen to compensate for the effects of DC bias current through the opamp input terminals. You will notice that the *parallel* combination of 52 k $\Omega$  and 91 k $\Omega$  is approximately equal to 33 k $\Omega$ . Explain why this is significant with reference to the Superposition theorem.

---

Answer 32

"Rolloff" refers to the *slope* of the Bode plot in the attenuating range of the filter circuit, usually expressed in units of decibels per octave (dB/octave) or decibels per decade (dB/decade):

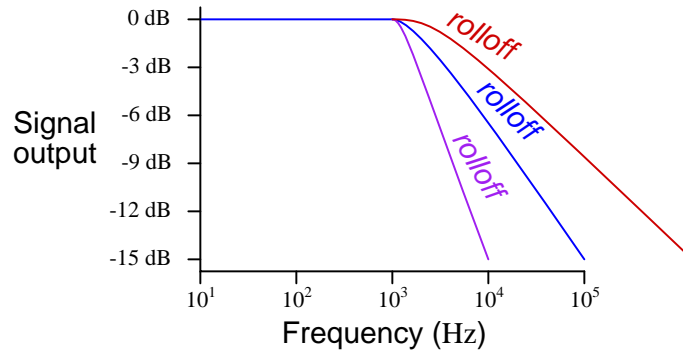

Answer 33

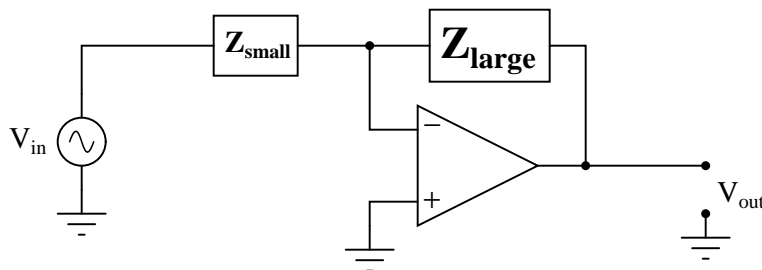

This opamp circuit has the greater voltage gain, because its  $\frac{Z_{feedback}}{Z_{input}}$  ratio is greater.

---

Answer 34

As the frequency of  $V_{in}$  increases,  $Z_C$  decreases and  $Z_R$  remains unchanged. This will result in an increased  $A_V$  for the amplifier circuit.

Follow-up question: normally we calculate the cutoff frequency of a simple RC filter circuit by determining the frequency at which  $R = X_C$ . Here, things are a little different. Determine the voltage gain ( $A_V$ ) when  $R = X_C$ , and also determine the phase shift from input to output.

Challenge question #1: explain why the phase shift from input to output for this circuit is always constant, regardless of signal frequency.

Challenge question #2: explain why this type of circuit is usually equipped with a low-value resistor ( $R_1$ ) in series with the input capacitor:

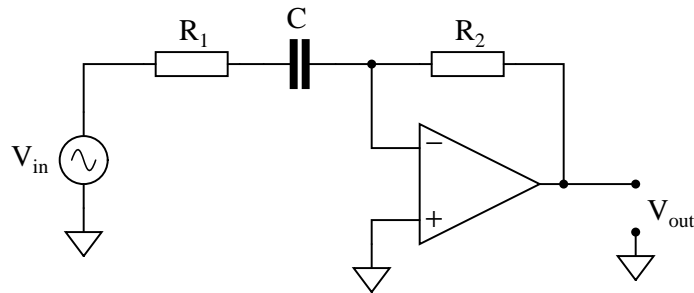

---

Answer 35

As the frequency of  $V_{in}$  increases,  $Z_C$  decreases and  $Z_R$  remains unchanged. This will result in a decreased  $A_V$  for the amplifier circuit.

Challenge question: explain why this type of circuit is usually equipped with a high-value resistor ( $R_2$ ) in parallel with the feedback capacitor:

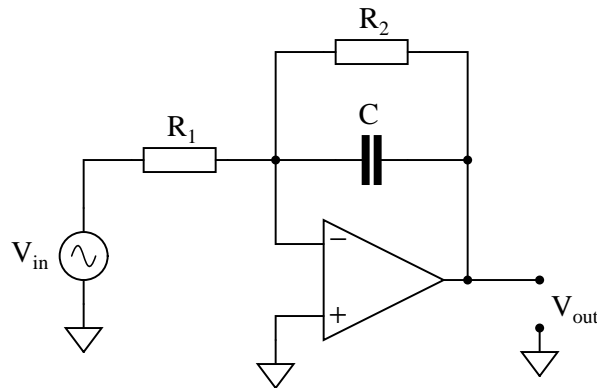

---

Answer 36

These are both low pass filters. The circuit with the shunt capacitor is the more practical one, because its voltage gain remains finite for all possible input signal frequencies:

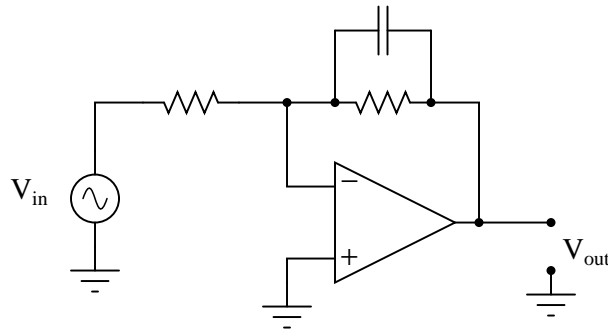

---

Answer 37

These are both high pass filters. The circuit with the series capacitor is the more practical one, because its voltage gain remains finite for all possible input signal frequencies:

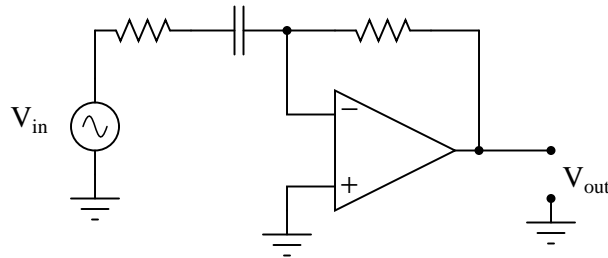

---

Answer 38

This is a band pass filter circuit.

---

Answer 39

This is a band stop filter circuit.

Challenge question: how much voltage gain does this amplifier have at resonance? How much voltage gain does it have at  $f = 0$  and  $f = \infty$ , if the two resistor values are equal?

---

Answer 40

The first filter shown is low pass, while the second filter shown is high pass.

Challenge question: what is the purpose of resistor  $R_3$  in each circuit?

---

Answer 41

Each of these terms describes a class of filter *responses*, rather than a particular circuit configuration (topology). The shape of the Bode plot for a filter circuit is the determining factor for whether it will be a "Chebyshev," "Butterworth," or "Bessel" filter.

---

Answer 42

Bear in mind that this is just one possible set of component values:

- $C = 3.3 \text{ nF}$
- $R = 9.744 \text{ k}\Omega$
- $\frac{R}{2} = 4.872 \text{ k}\Omega$

Follow-up question: how would you suggest we obtain the precise resistance values necessary to build this circuit?

---

Answer 43

Bear in mind that this is just one possible set of component values:

- $C = 0.0047 \text{ }\mu\text{F}$
- $2C = 0.0094 \text{ }\mu\text{F}$
- $R = 5.701 \text{ k}\Omega$
- $2R = 11.402 \text{ k}\Omega$

Follow-up question: while  $0.0047 \text{ }\mu\text{F}$  is a common capacitor size,  $0.0094 \text{ }\mu\text{F}$  is not. Explain how you could obtain this precise value of capacitance needed to build this circuit.

---

Answer 44

The first filter shown is a band-stop, while the second filter shown is a band-pass.

---

Answer 45

I'll let you figure out the function of opamps  $U_4$ ,  $U_5$ , and  $U_6$  on your own!

---

Answer 46

Eventually, the voltage across capacitor  $C_2$  would be equal to the battery voltage.

Challenge question: how do the relative sizes of the capacitors (in Farads) affect this process? For example, what if  $C_1 = 10 \text{ }\mu\text{F}$  and  $C_2 = 470 \text{ }\mu\text{F}$ ? Or, what if  $C_1 = 330 \text{ }\mu\text{F}$  and  $C_2 = 2.2 \text{ }\mu\text{F}$ ? Explain your answer.

---

Answer 47

*Flying capacitor* circuits are used to provide galvanic isolation between a sampled voltage source and voltage measurement circuitry.

---

Answer 48

The switching frequency of the flying capacitor circuit *must* exceed the output frequency of the alternator by a substantial margin, or else the signal shape will not be faithfully reproduced at the circuit's output.

Challenge question: if you were the technician or engineer on this project, what switching frequency would you suggest for the flying capacitor circuit? How would this criterion affect the design of the flying capacitor circuit itself (capacitor values, relay versus transistor switches)?

---

Answer 49

Average load current increases as clock frequency increases:  $R = \frac{1}{fC}$

---

Answer 50

Average load current increases as clock frequency increases:  $R = \frac{1}{fC}$

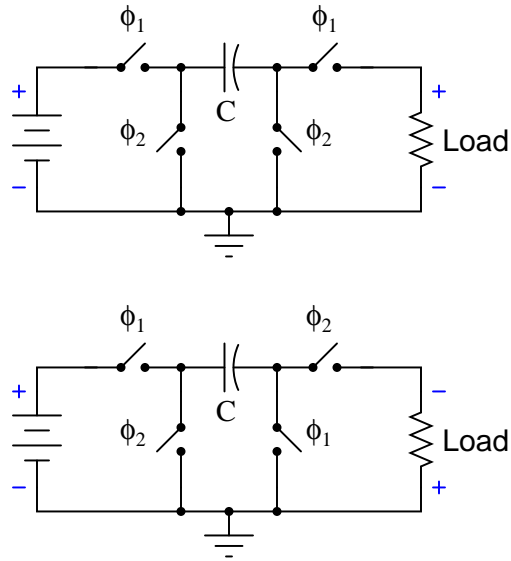

The op-amp circuit will act as an inverting or non-inverting amplifier, depending on the switching sequence. Gain will be affected by switching frequency.

Challenge question: the second switched capacitor network is often referred to as a *negative resistor* equivalent. Explain why.

Answer 52

Circuit **A**: Parallel circuit  $R = \frac{1}{fC}$

Circuit **B**: Series circuit  $R = \frac{1}{fC}$

Circuit **C**: Series-parallel circuit  $R = \frac{1}{f(C_1+C_2)}$

Circuit **D**: Bilinear circuit  $R = \frac{1}{4fC}$

Circuit **E**: Negative transresistor circuit  $R = -\frac{1}{fC}$  (the negative sign indicates polarity inversion)

Circuit **F**: Positive transresistor circuit  $R = \frac{1}{fC}$

---

Answer 53

Switched-capacitor networks allow us to have *electronically variable resistors* inside integrated circuits, with no moving parts, which is a technological advantage over standard resistors. Another advantage of switched-capacitor circuits is that they typically require less substrate area on an integrated circuit than an equivalent resistor. A huge advantage is that switched-capacitor networks may be manufactured to give much more accurate resistances than plain resistors, which is important in filtering applications.

I'll let you research (or dream up) some practical applications for this technology.

---

Answer 54

This is a *lowpass* filter circuit:

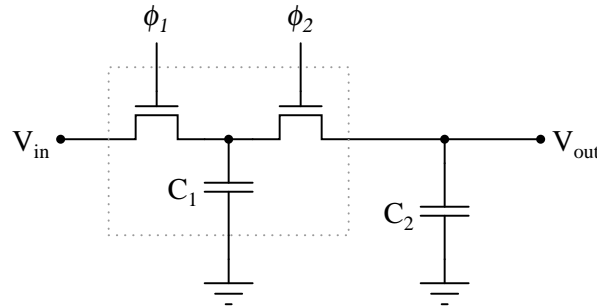

$$f_{-3dB} = \frac{f_{switch} C_1}{2\pi C_2}$$

Note: in order for this circuit to be practical,  $f_{switch} \gg f_{signal}$ .

---

Answer 55

This is a *highpass* filter circuit:

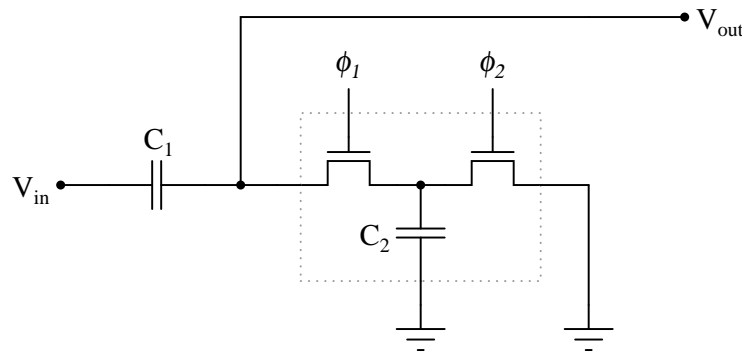

$$f_{-3dB} = \frac{f_{switch} C_2}{2\pi C_1}$$

Note: in order for this circuit to be practical,  $f_{switch} \gg f_{signal}$ .

---

Answer 56

Use circuit simulation software to verify your predicted and measured parameter values.

---

Answer 57

Use circuit simulation software to verify your predicted and measured parameter values.

---

Answer 58

Use circuit simulation software to verify your predicted and measured parameter values.

---

Answer 59

Use circuit simulation software to verify your predicted and measured parameter values.

---

Answer 60

Use circuit simulation software to verify your predicted and measured parameter values.

---

Answer 61

Be sure you meet with your instructor if you have any questions about what is expected for your project!

---

Answer 62

The resonant frequency of the circuit would *increase*.

Challenge question: what would happen to the  $Q$  of this filter circuit as a result of the fault within the inductor?

---

Answer 63

This is perhaps the easiest solution, to install a very large capacitor ( $C_{huge}$ ) in parallel with the audio load:

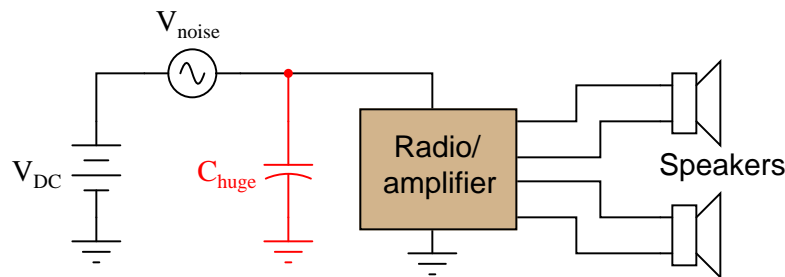

Other, more sophisticated solutions exist, however!

Follow-up question: use superposition theorem to show *why* the capacitor mitigates the electrical noise without interfering with the transfer of DC power to the radio/amplifier.

---

Answer 64

- Capacitor  $C_1$  fails open: *No output signal at all.*
- Capacitor  $C_2$  fails shorted: *The circuit becomes a first-order filter with  $f_{cutoff} = \frac{R_1+R_2}{2\pi R_1 R_2 C}$ .*
- Resistor  $R_1$  fails open: *The circuit becomes a first-order filter with  $f_{cutoff} = \frac{C_1+C_2}{2\pi R_2 C_1 C_2}$ .*
- Resistor  $R_2$  fails open: *The circuit becomes a first-order filter with  $f_{cutoff} = \frac{1}{2\pi R_1 C_1}$  (assuming no load on the output).*
- Solder bridge (short) across resistor  $R_2$ : *No output signal at all.*



---

Answer 65

- Resistor  $R_1$  fails open: *Filter circuit stops filtering, passes all frequencies.*
- Capacitor  $C_1$  fails open: *No signal output at all from the circuit.*
- Solder bridge (short) across resistor  $R_1$ : *No signal output at all from the circuit.*
- Solder bridge (short) across capacitor  $C_1$ : *Filter circuit stops filtering, passes all frequencies.*
- Resistor  $R_2$  fails open: *Voltage gain of circuit decreases to value of 1 (0 dB).*
- Resistor  $R_3$  fails open: *Filter circuit outputs square wave at all frequencies.*

---

Answer 66

- Resistor  $R_1$  fails open: *No signal output at all from the circuit.*
- Capacitor  $C_1$  fails open: *Filter circuit stops filtering, passes all frequencies.*
- Solder bridge (short) across resistor  $R_1$ : *Filter circuit stops filtering, passes all frequencies.*
- Solder bridge (short) across capacitor  $C_1$ : *No signal output at all from the circuit.*
- Resistor  $R_2$  fails open: *Voltage gain of circuit decreases to value of 1 (0 dB).*
- Resistor  $R_3$  fails open: *Filter circuit outputs square wave at all frequencies.*

---

Answer 67

- Resistor  $R_1$  fails open: *Output signal is always a square wave.*
- Capacitor  $C_1$  fails open: *No output signal at all.*
- Solder bridge (short) across resistor  $R_1$ : *No output signal at all.*
- Solder bridge (short) across capacitor  $C_1$ : *Output signal is always a square wave.*

---

Answer 68

- Resistor  $R_1$  fails open: *No output signal at all.*
- Resistor  $R_2$  fails open: *Output saturates (either positive or negative) when there is any DC voltage input to the circuit.*
- Capacitor  $C_1$  fails open: *No filtering action at all, merely operates as a fixed-gain amplifier.*
- Solder bridge (short) across resistor  $R_1$ : *Output signal is always a square wave.*
- Solder bridge (short) across resistor  $R_2$ : *No output signal at all.*
- Solder bridge (short) across capacitor  $C_1$ : *No output signal at all.*

---

Answer 69

- Resistor  $R_1$  fails open: *No output signal at all.*
- Resistor  $R_2$  fails open: *Output signal is always a square wave.*
- Capacitor  $C_1$  fails open: *No output signal at all.*
- Solder bridge (short) across resistor  $R_1$ : *Output signal is a square wave at high frequencies (too much high-frequency gain).*
- Solder bridge (short) across resistor  $R_2$ : *No output signal at all.*
- Solder bridge (short) across capacitor  $C_1$ : *No filtering action at all, merely operates as a fixed-gain amplifier.*

---

Answer 70

Please note that the following list is not exhaustive. That is, other component faults may be possible!

One resistor failure (either open or shorted) that could cause this to happen:  $R_8$  failed open.

One capacitor failure (either open or shorted) that could cause this to happen:  $C_2$  failed shorted.

One opamp failure that could cause this to happen:  $U_4$  failed.

---

Answer 71

Please note that the following list is not exhaustive. That is, other component faults may be possible!

One resistor failure (either open or shorted) that could cause this to happen:  $R_2$  failed open.

One opamp failure that could cause this to happen:  $U_2$  failed.

---

Answer 72

Active loads act as constant-current sources feeding a constant (maximum) current through any capacitances in their way. This leads to constant  $\frac{dv}{dt}$  rates according to the "Ohm's Law" equation for capacitors:

$$i = C \frac{dv}{dt}$$

Follow-up question: based on what you see here, determine what parameters could be changed within the internal circuitry of an operational amplifier to increase the slew rate.

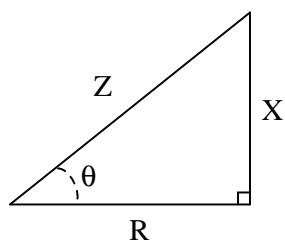

$$\frac{X}{R} = \tan \Theta = \frac{\text{Opposite}}{\text{Adjacent}}$$

$$\frac{X}{Z} = \sin \Theta = \frac{\text{Opposite}}{\text{Hypotenuse}}$$

$$\frac{R}{Z} = \cos \Theta = \frac{\text{Adjacent}}{\text{Hypotenuse}}$$

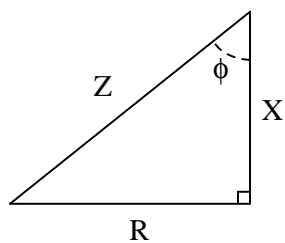

$$\frac{R}{X} = \tan \phi = \frac{\text{Opposite}}{\text{Adjacent}}$$

$$\frac{X}{Z} = \cos \phi = \frac{\text{Adjacent}}{\text{Hypotenuse}}$$

$$\frac{R}{Z} = \sin \phi = \frac{\text{Opposite}}{\text{Hypotenuse}}$$

---

Answer 75

Each side of the impedance triangle is actually a *phasor* (a vector representing impedance with magnitude and direction):

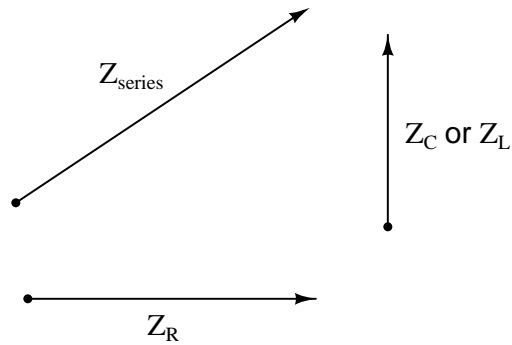

Since the phasor for resistive impedance ( $Z_R$ ) has an angle of zero degrees and the phasor for reactive impedance ( $Z_C$  or  $Z_L$ ) either has an angle of  $+90$  or  $-90$  degrees, the *phasor sum* representing total series impedance will form the hypotenuse of a right triangle when the first two phasors are added (tip-to-tail).

Follow-up question: as a review, explain why resistive impedance phasors always have an angle of zero degrees, and why reactive impedance phasors always have angles of either  $+90$  degrees or  $-90$  degrees.

---

Answer 76

Impedances do not add in parallel.

Follow-up question: what kind of a triangle *could* be properly applied to a parallel AC circuit, and why?

---

Answer 77

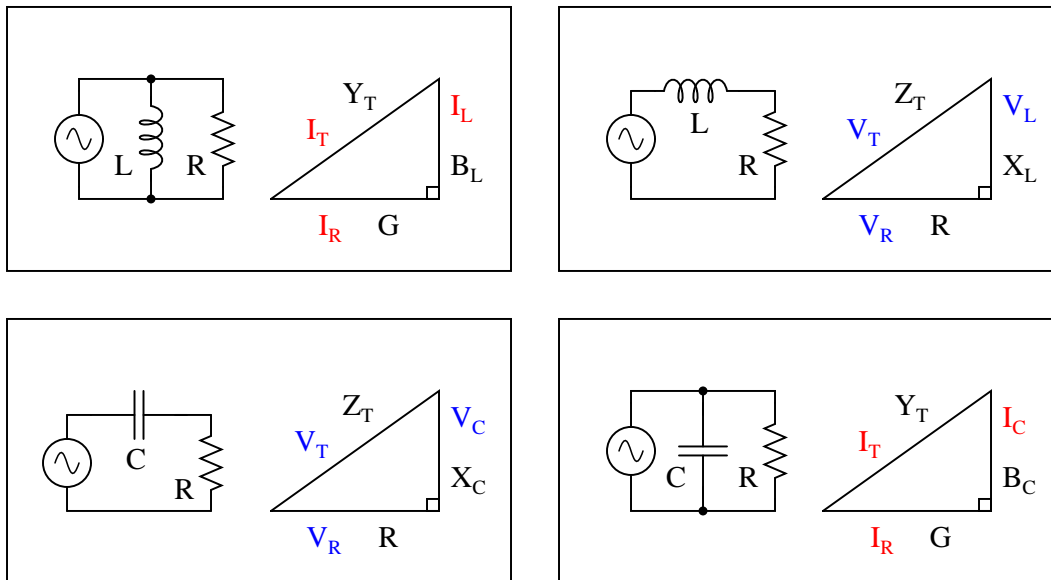

---

Answer 78

$X = 105 \Omega$ , as calculated by an algebraically manipulated version of the Pythagorean Theorem.

---

Answer 79

$X = 9.063 \text{ k}\Omega$

---

Answer 80

$R = 2.165 \text{ k}\Omega$

$X = 1.25 \text{ k}\Omega$

---

Answer 81

$I_{total} = 16.12 \text{ amps}$

$\Theta = 60.26^\circ$  (negative, if you wish to represent the angle according to the standard coordinate system for phasors).

Follow-up question: in calculating  $\Theta$ , it is recommended to use the arctangent function instead of either the arcsine or arc-cosine functions. The reason for doing this is accuracy: less possibility of compounded error, due to either rounding and/or calculator-related (keystroke) errors. Explain why the use of the arctangent function to calculate  $\Theta$  incurs less chance of error than either of the other two arcfunctions.

---

Answer 82

$G = 24.75 \mu\text{S}$

Follow-up question: how much resistance is this, in ohms?

---

Answer 83

*Passive integrator circuit  
impedance triangle*

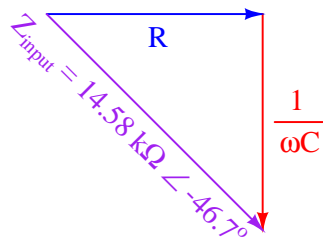

*Active integrator circuit  
impedance triangle*

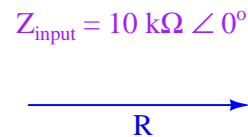

---

Answer 84

$\Theta = 46.7^\circ$  for the passive integrator current, while  $\Theta = 0^\circ$  for the active integrator circuit.

---

Answer 85

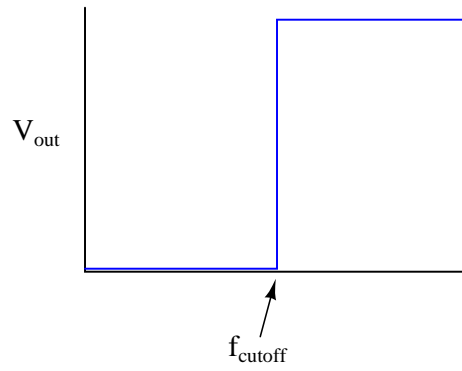

Follow-up question: a theoretical filter with this kind of idealized response is sometimes referred to as a "brick wall" filter. Explain why this name is appropriate.

---

Answer 86

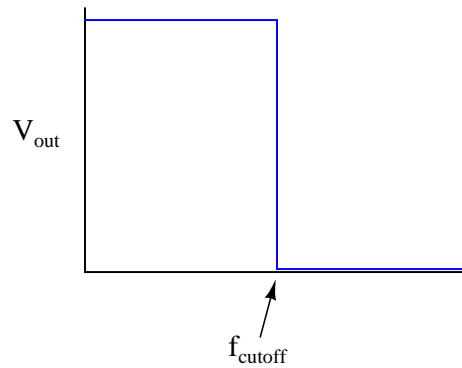

Follow-up question: a theoretical filter with this kind of idealized response is sometimes referred to as a "brick wall" filter. Explain why this name is appropriate.

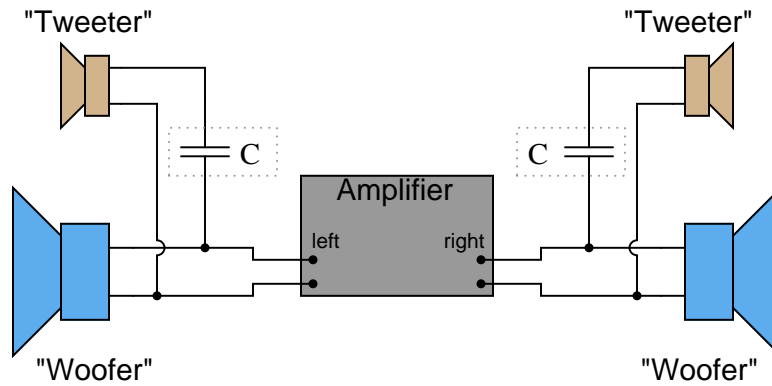

Follow-up question: what type of capacitor would you recommend using in this application (electrolytic, mylar, ceramic, etc.)? Why?

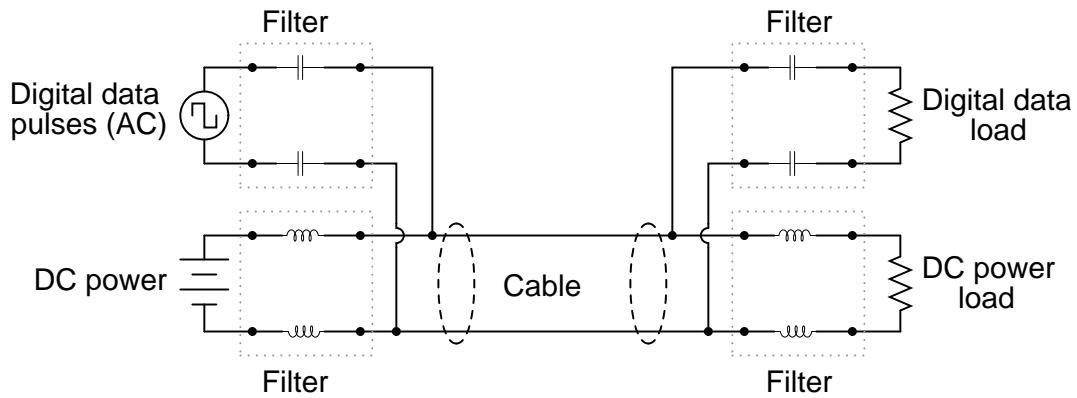

Follow-up question #1: how might the *superposition theorem* be applied to this circuit, for the purposes of analyzing its function?

Follow-up question #2: suppose one of the capacitors were to fail shorted. Identify what effect, if any, this would have on the operation of the circuit. What if two capacitors were to fail shorted? Would it matter if those two capacitors were both on either the transmitting or the receiving side, or if one of the failed capacitors was on the transmitting side and the other was on the receiving side?

This is a *high-pass* filter.

$$R = 2\pi fL$$

$$R = 5.65 \text{ k}\Omega$$

---

Answer 90

This circuit is a *band-pass* filter.

---

Answer 91

This circuit is a *band-stop* filter.

---

Answer 92

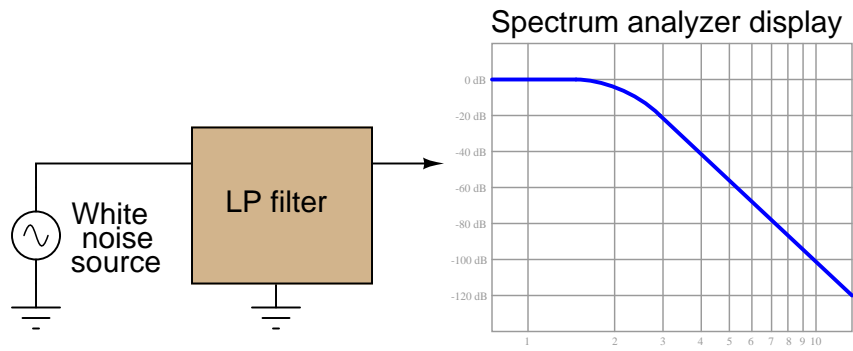
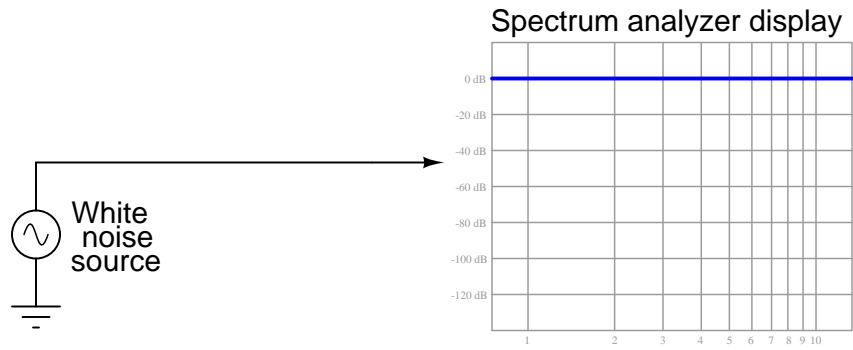



Notes 1

Students should realize that this is no hypothetical question. Intrinsic capacitance does indeed exist between the collector and base of a bipolar junction transistor (called the *Miller capacitance*), and this has a degenerating effect on voltage gain with increasing frequency. If time permits, you may wish to discuss how the common-collector and common-base amplifier configurations naturally avoid this problem.

---

Notes 2

The purpose of this question is to get students to see, on a discrete component level, that for common-emitter amplifier there is a tradeoff between maximum gain and maximum operating frequency. This question foreshadows the concept of Gain-Bandwidth Product (GBW) in operational amplifier circuits.

---

Notes 3

Note that I chose to use the word "mitigate" instead of give the answer in more plain English. Part of my reasoning here is to veil the given answer from immediate comprehension so that students must *think* a bit more. Another part of my reasoning is to force students' vocabularies to expand.

---

Notes 4

Your students should have researched datasheets for the CA3130 op-amp in search of an answer to this question. Ask them what they found! Which terminals on the CA3130 op-amp do you connect the capacitor between? What size of capacitor is appropriate for this purpose?

Given the fact that some op-amp models come equipped with their own built-in compensation capacitor, what does this tell us about the CA3130's need for an external capacitor? Why didn't the manufacturer simply integrate a compensation capacitor into the CA3130's circuitry as they did with the 741? Or, to phrase the question more directly, ask your students to explain what *disadvantage* there is in connecting a compensation capacitor to an op-amp.

---

Notes 5

Answering this question will require a review of basic transistor amplifier theory, specifically different configurations of transistor amplifiers and their respective signal phase relationships.

---

Notes 6

Ask your students to explain why we might wish to use either type of opamp when building a circuit. In what applications do they think an internally-compensated opamp would be better, and in what applications do they think an externally-compensated opamp would be preferable?

---

Notes 7

There are other means of defining Gain-Bandwidth Product, so do not be surprised if students present alternative definitions during the discussion time.

---

Notes 8

It does not require a great deal of insight to recognize that unity-gain bandwidth ( $B_1$ ) and gain-bandwidth product (GBW) are pretty much the same thing. This would be a good point to bring up (in the form of a question!) for your students if you have already discussed GBW.

---

Notes 9

In this question, the really important aspect is not the answer given. What is important here is that students understand what GBW product is, and how it is affected by this thing we call "compensation capacitance" (another topic of research). The goal here is to get students to research these concepts and relate them together, so please do not be satisfied with any student answers that merely restate the answer given here! Ask students to explain what these terms and concepts mean, and to explain *why* the GBW product decreases with increased  $C_{comp}$ .

---

Notes 10

The follow-up question is very important, as it asks students to apply the concept of a maximum  $\frac{dv}{dt}$  to actual waveshapes. This is often discussed by introductory textbooks, though, so it should not be difficult for students to find good information to help them formulate an answer.

---

Notes 11

Ask your students how they were able to make the determination of greater voltage drop. Which method yields the fastest solution (i.e. requires the fewest steps)?

---

Notes 12

Ask your students how they arrived at their answers for these qualitative assessments. If they found difficulty understanding the relationship of frequency to impedance for reactive components, I suggest you work through the reactance equations qualitatively with them. In other words, evaluate each of the reactance formulae ( $X_L = 2\pi fL$  and  $X_C = \frac{1}{2\pi fC}$ ) in terms of  $f$  increasing and decreasing, to understand how each of these components reacts to low- and high-frequency signals.

---

Notes 13

Low-pass and high-pass filter circuit are really easy to identify if you consider the input frequencies in terms of extremes: radio frequency (very high), and DC ( $f = 0$  Hz). Ask your students to identify the respective impedances of all components in a filter circuit for these extreme frequency examples, and the functions of each filter circuit should become very clear to see.

---

Notes 14

Be sure to ask students where they found the cutoff frequency formula for this filter circuit.

When students calculate the impedance of the resistor and the capacitor at the cutoff frequency, they should notice something unique. Ask your students why these values are what they are at the cutoff frequency. Is this just a coincidence, or does this tell us more about how the "cutoff frequency" is defined for an RC circuit?

---

Notes 15

This is an exercise in algebraic substitution, taking the formula  $X = R$  and introducing  $f$  into it by way of substitution, then solving for  $f$ . Too many students try to memorize every new thing rather than build their knowledge upon previously learned material. It is surprising how many electrical and electronic formulae one may derive from just a handful of fundamental equations, if one knows how to use algebra.

Some textbooks present the LR cutoff frequency formula like this:

$$f_{cutoff} = \frac{1}{2\pi \frac{L}{R}}$$

If students present this formula, you can be fairly sure they simply found it somewhere rather than derived it using algebra. Of course, this formula is exactly equivalent to the one I give in my answer – and it is good to show the class how these two are equivalent – but the real point of this question is to get your students using algebra as a practical tool in their understanding of electrical theory.

---

Notes 16

Challenge your students to describe how to change stations on this radio receiver. For example, if we are listening to a station broadcasting at 1000 kHz and we want to change to a station broadcasting at 1150 kHz, what do we have to do to the circuit?

Be sure to discuss with them the construction of an adjustable capacitor (air dielectric).

---

Notes 17

Some of these filter designs are resonant in nature, while others are not. Resonant circuits, especially when made with high-Q components, approach ideal band-pass (or -block) characteristics. Discuss with your students the different design strategies between resonant and non-resonant band filters.

The high-pass filter containing both inductors and capacitors may at first appear to be some form of resonant (i.e. band-pass or band-stop) filter. It actually *will* resonate at some frequency(ies), but its overall behavior is still high-pass. If students ask about this, you may best answer their queries by using computer simulation software to plot the behavior of a similar circuit (or by suggesting they do the simulation themselves).

Regarding the follow-up question, it would be a good exercise to discuss which suggested component failures are more likely than others, given the relatively likelihood for capacitors to fail shorted and inductors and resistors to fail open.

---

Notes 18

Some of these filter designs are resonant in nature, while others are not. Resonant circuits, especially when made with high-Q components, approach ideal band-pass (or -block) characteristics. Discuss with your students the different design strategies between resonant and non-resonant band filters.

Although resonant band filter designs have nearly ideal (theoretical) characteristics, band filters built with capacitors and resistors only are also popular. Ask your students why this might be. Is there any reason inductors might purposefully be avoided when designing filter circuits?

---

Notes 19

Although power line carrier technology is not used as much for communication in high-voltage distribution systems as it used to be – now that microwave, fiber optic, and satellite communications technology has superseded this older technique – it is still used in lower voltage power systems including residential (home) wiring. Ask your students if they have heard of any consumer technology capable of broadcasting any kind of data or information along receptacle wiring. "X10" is a mature technology for doing this, and at this time (2004) there are devices available on the market allowing one to plug telephones into power receptacles to link phones in different rooms together without having to add special telephone cabling.

Even if your students have not yet learned about three-phase power systems or transformers, they should still be able to discern the circuit path of the communications signal, based on what they know of capacitors and inductors, and how they respond to signals of arbitrarily high frequency.

Information on the coupling capacitor units was obtained from page 452 of the *Industrial Electronics Reference Book*, published by John Wiley & Sons in 1948 (fourth printing, June 1953). Although power line carrier technology is not as widely used now as it was back then, I believe it holds great educational value to students just learning about filter circuits and the idea of mixing signals of differing frequency in the same circuit.

---

Notes 20

Although "bandwidth" is usually applied first to band-pass and band-stop filters, students need to realize that it applies to the other filter types as well. This question, in addition to reviewing the definition of bandwidth, also reviews the definition of cutoff frequency. Ask your students to explain where the 70.7% figure comes from. Hint: *half-power* point!

---

Notes 21

This is merely an exercise in algebra. However, knowing how these three component values affects the Q factor of a resonant circuit is a valuable and practical insight!

---

Notes 22

Note that no component values are given in this question, only the condition that both circuits are operating at the cutoff frequency. This may cause trouble for some students, because they are only comfortable with numerical calculations. The structure of this question forces students to think a bit differently than they might be accustomed to.

---

Notes 23

Phase-shifting circuits are very useful, and important to understand. They are particularly important in some types of oscillator circuits, which rely on RC networks such as this to provide certain phase shifts to sustain oscillation.

---

Notes 24

Phase-shifting circuits are very useful, and important to understand. They are particularly important in some types of oscillator circuits, which rely on RC networks such as this to provide certain phase shifts to sustain oscillation.

---

Notes 25

It is essential, of course, that students understand the operational principle of this circuit before they may even attempt to diagnose possible faults. You may find it necessary to discuss this circuit in detail with your students before they are ready to troubleshoot it.

In case anyone asks, the symbolism  $R_{pot} \gg R$  means "potentiometer resistance is *much* greater than the fixed resistance value."

---

Notes 26

Nothing fancy here, just a review of passive RC filter circuitry.

---

Notes 27

Ask your students to define what "cutoff frequency" means. There is more than one definition: one based on output voltage, and one based on output power. When defined in terms of power, the cutoff frequency is sometimes described as  $f_{-3dB}$ .

---

Notes 28

Ask your students what the function of the opamp is, taken by itself. What do we call an opamp that has its output directly connected to its inverting input? How does this function and name relate to the granting of load-impedance immunity in the filter circuit shown in the question?

---

Notes 29

Ask your students what the function of the op-amp is (with potentiometer feedback), taken by itself. If there were no filter circuit in place at all, but  $V_{in}$  connected straight to the op-amp's noninverting input, what function would the potentiometer adjustment serve?

---

Notes 30

Ask your students to explain how they arrived at their answers: what formulae did they use, and how did they determine the type of the filter circuit that this is? Ask them if there was any information given in the diagram irrelevant to either determination.

---

---

Notes 31

Ask your students to explain how they arrived at their answers: what formulae did they use, and how did they determine the type of the filter circuit that this is? Ask them if there was any information given in the diagram irrelevant to either determination.

---

Notes 32

Point students' attention to the scale used on this particular Bode plot. This is called a *log-log* scale, where neither vertical nor horizontal axis is linearly marked. This scaling allows a very wide range of conditions to be shown on a relatively small plot, and is very common in filter circuit analysis.

---

Notes 33

It is common to see impedances represented as boxes, if their constituent components are not germane to the operation of the circuit.

---

Notes 34

The answer I've given is technically correct, but there is a practical limit here. As we know, the intrinsic gain of an op-amp does not remain constant as signal frequency rises. Ask your students to describe the impact of this phenomenon on the circuit's performance at very high frequencies.

On another note, this same op-amp circuit is known by a particular name when used with DC input signals. Ask your students what this design of circuit is called.

---

Notes 35

This same op-amp circuit is known by a particular name when used with DC input signals. Ask your students what this design of circuit is called. When receiving a DC input signal, what function does it serve? The answer to this is key to answering the "challenge" question.

---

Notes 36

Discuss with your students their methods of determining filter type. How did they approach this problem, to see what type of filter both these circuits were?

Also, discuss with your students the problem of having an amplifier circuit with an unchecked gain (approaching infinity). Ask them what is wrong with obtaining such high voltage gains from any amplifier. Have them describe to you the effect of a huge voltage gain on the integrity of the amplified signal.

---

Notes 37

Discuss with your students their methods of determining filter type. How did they approach this problem, to see what type of filter both these circuits were?

Also, discuss with your students the problem of having an amplifier circuit with an unchecked gain (approaching infinity). Ask them what is wrong with obtaining such high voltage gains from any amplifier. Have them describe to you the effect of a huge voltage gain on the integrity of the amplified signal.

---

Notes 38

Discuss with your students their methods of determining filter type. How did they approach this problem, to see what type of filter this circuit was? Determining the identify of a "band-" filter is more difficult than with a low- or a high- pass filter circuit, because the behavior is roughly the same at both extremes of the frequency range.

---

Notes 39

If some students have difficulty analyzing the function of this circuit, ask them to identify the total impedance of a series-connected inductor and capacitor at resonance, then transfer that amount of impedance to the circuit to see what the effects will be at the resonant frequency.

---

---

Notes 40

The word "topology" may be strange to your students. If any of them ask you what it means, ask them if they own a dictionary!

Like all the other active filter circuits, the fundamental characteristic of each filter may be determined by qualitative analysis at  $f = 0$  and  $f = \infty$ . This is a form of *thought experiment*: determining the characteristics of a circuit by imagining the effects of certain given conditions, following through by analysis based on "first principles" of circuits, rather than by researching what the circuit's intended function is.

Resistor  $R_3$  is actually not essential to the circuit's operation, but is normally found in Sallen-Key filters anyway. If it makes the analysis of the circuit any simpler, tell your students they may replace that resistor with a straight wire in their schematic diagrams.

---

Notes 41

I purposely omitted Bode plot examples for these three filter classifications. Presentation and examination of Bode plots is an appropriate activity for discussion time. Draw a set of Bode plot axes on the whiteboard, and then have students draw approximate Bode plots for each filter response, as determined from their research.

---

Notes 42

In order for students to solve for  $R$ , they must algebraically manipulate the cutoff frequency formula. Ask them why we might choose a standard value for capacitance and then calculate a non-standard value for resistance. Why not the other way around (first choose  $R$ , then calculate  $C$ )?

---

Notes 43

In order for students to solve for  $R$ , they must algebraically manipulate the cutoff frequency formula. Ask them why we might choose a standard value for capacitance and then calculate a non-standard value for resistance. Why not the other way around (first choose  $R$ , then calculate  $C$ )?

---

Notes 44

Like all the other active filter circuits, the fundamental characteristic of each filter may be determined by qualitative analysis at  $f = 0$  and  $f = \infty$ .

An interesting concept at work here is the inversion of a function by placement inside the feedback loop of a negative-feedback opamp circuit. What is a band-stop filter all by itself forces the opamp to be a band-pass if placed within the negative feedback signal path. Discuss this very important concept with your students, as this is most definitely not the only application for it!

---

Notes 45

Not only does this circuit illustrate a neat application of opamps, but it also showcases modular operational circuit design, where each opamp (and its supporting passive components) performs exactly one task.

---

Notes 46

This question previews *flying capacitor* circuits.

---

Notes 47

I once worked for a company where thousands of these "flying capacitor" circuits were used to sample voltage across numerous series-connected electrochemical reduction cells, whose common-mode voltage could easily exceed 500 volts DC! This primitive technology provided isolation so that the data acquisition circuitry did not have to deal with that high common-mode voltage.

Incidentally, the relays we used were hermetically sealed, mercury-wetted contact, reed relays. These relays had a surprisingly long life, often several years! They were cycled at around 20 Hz, for several cycles, about once every minute (24 hours per day, 365 days per year).

---

Notes 48

Ask your students to sketch an approximation of the flying capacitor circuit's output waveform for different sampling frequencies. This question is a great lead-in to a discussion on Nyquist frequency, if your students are ready for it!

An important aspect of this question is for students to generalize from this specific circuit example to all systems where signals are sampled along discrete time intervals. In modern electronic circuitry, especially data acquisition circuitry, sample time can be a significant issue. In my experience, it is one of the primary reasons for digital systems giving poor results.

---

Notes 49

Perhaps the most important aspect of this question is students' analytical reasoning: *how* did they analyze the two circuits to arrive at their answers? Be sure to devote adequate class time to a discussion of this, helping the weaker students grasp the concept of switched-capacitor/resistor equivalency by allowing stronger students to present their arguments.

---

Notes 50

Perhaps the most important aspect of this question is students' analytical reasoning: *how* did they analyze the two circuits to arrive at their answers? Be sure to devote adequate class time to a discussion of this, helping the weaker students grasp the concept of switched-capacitor/resistor equivalency by allowing stronger students to present their arguments.

---

Notes 51

Some of the versatility of switched capacitor networks can be seen in these two circuit examples. Really, they're the same circuit, just operated differently. Discuss with your students how this versatility may be an advantage in circuit design.

---

Notes 52

The mathematics required to derive these equations directly may be beyond your students' ability, but they should still be able to research them! Some of the networks are directly equivalent to one another, making it easier for your students to associate equations: for instance, circuit **F** is equivalent to circuit **B**, and circuit **E** is the same thing as **F** except for the polarity inversion. It should not take a great deal of analysis to realize that circuits **A** and **B** must have the same equation as well.

---

Notes 53

This question could very well lead to an interesting and lively discussion with your students. Once students recognize the equivalence between switched-capacitor networks and resistors, it is a short cognitive leap from there to practical applications where variable resistances would be useful (especially in an integrated circuit environment, where moving parts have traditionally been out of the question).

---

Notes 54

This question asks students to substitute a switched capacitor network for the fixed resistor in the original filter circuit. Similarly, algebraic substitution is required to derive the equation for cutoff frequency.

---

Notes 55

This question asks students to substitute a switched capacitor network for the fixed resistor in the original filter circuit. Similarly, algebraic substitution is required to derive the equation for cutoff frequency.

---

Use a dual-voltage, regulated power supply to supply power to the opamp. I recommend using a "slow" op-amp to make the slewing more easily noticeable. If a student chooses a relatively fast-slew op-amp such as the TL082, their signal frequency may have to go up into the megahertz range before the slewing becomes evident. At these speeds, parasitic inductance and capacitance in their breadboards and test leads will cause bad "ringing" and other artifacts muddling the interpretation of the circuit's performance.

I have had good success using the following values:

- $+V = +12$  volts
- $-V = -12$  volts
- $V_{in} = 4$  V peak-to-peak, at 300 kHz
- $U_1 =$  one-half of LM1458 dual operational amplifier

An extension of this exercise is to incorporate troubleshooting questions. Whether using this exercise as a performance assessment or simply as a concept-building lab, you might want to follow up your students' results by asking them to predict the consequences of certain circuit faults.

---

The purpose of this exercise is to empirically determine the gain-bandwidth product (GBW) of a closed-loop opamp amplifier circuit by setting it up for three different closed-loop gains ( $A_{CL}$ ), measuring the cutoff frequency ( $f_{-3dB}$ ) at those gains, and calculating the product of the two ( $A_{CL}f_{-3dB}$ ) at each gain. Since this amplifier is DC-coupled, there is no need to measure a lower cutoff frequency in order to calculate *bandwidth*, just the high cutoff frequency.

What GBW tells us is that any opamp has the tendency to act as a low-pass filter, its cutoff frequency being dependent on how much gain we are trying to get out of the opamp. We can have large gain at modest frequencies, or a high bandwidth at modest gain, but not both! This lab exercise is designed to let students see this limitation. As they set up their opamp circuits with greater and greater gains ( $\frac{R_2}{R_1} + 1$ ), they will notice the opamp "cut off" like a low-pass filter at lower and lower frequencies.

For the "given" value of unity-gain frequency, you must consult the datasheet for the opamp you choose. I like to use the popular TL082 BiFET opamp for a lot of AC circuits, because it delivers good performance at a modest price and excellent availability. However, the GBW for the TL082 is so high (3 MHz typical) that breadboard and wiring layout become issues when testing at low gains, due to the resulting high frequencies necessary to show cutoff. The venerable 741 is a better option because its gain-bandwidth product is significantly lower (1 to 1.5 MHz typical).

It is very important in this exercise to maintain an undistorted opamp output, even when the closed-loop gain is very high. Failure to do so will result in the  $f_{-3dB}$  points being skewed by slew-rate limiting. What we're looking for here are the cutoff frequencies resulting from loss of small-signal open-loop gain ( $A_{OL}$ ) inside the opamp. To maintain small-signal status, we must ensure the signal is not being distorted!

Some typical values I was able to calculate for GBW product are  $3.8 \times 10^6$  for the BiFET TL082,  $1.5 \times 10^6$  for the LM1458, and around  $800 \times 10^3$  for the LM741C.

An extension of this exercise is to incorporate troubleshooting questions. Whether using this exercise as a performance assessment or simply as a concept-building lab, you might want to follow up your students' results by asking them to predict the consequences of certain circuit faults.



I recommend setting the function generator output for 1 volt, to make it easier for students to measure the point of "cutoff". You may set it at some other value, though, if you so choose (or let students set the value themselves when they test the circuit!).

For capacitors, I recommend students choose three (3) capacitors of equal value if they wish to build the Sallen-Key circuit with a Butterworth response (where  $C_2 = 2C_1$ ). Capacitor  $C_1$  will be a single capacitor, while capacitor  $C_2$  will be two capacitors connected in parallel. This generally ensures a more precise 1:2 ratio than choosing individual components.

I also recommend having students use an oscilloscope to measure AC voltage in a circuit such as this, because some digital multimeters have difficulty accurately measuring AC voltage much beyond line frequency range. I find it particularly helpful to set the oscilloscope to the "X-Y" mode so that it draws a thin line on the screen rather than sweeps across the screen to show an actual waveform. This makes it easier to measure peak-to-peak voltage.

Values that have proven to work well for this exercise are given here, although of course many other values are possible:

- $+V = +12$  volts
- $-V = -12$  volts
- $R_1 = 10$  k $\Omega$
- $R_2 = 10$  k $\Omega$
- $R_{comp} = 20$  k $\Omega$  (actually, two 10 k $\Omega$  resistors in series)
- $C_1 = 0.001$   $\mu$ F
- $C_2 = 0.002$   $\mu$ F (actually, two 0.001  $\mu$ F capacitors in parallel)
- $U_1 =$  one-half of LM1458 dual operational amplifier

This combination of components gave a predicted cutoff frequency of 11.25 kHz, with an actual cutoff frequency (not factoring in component tolerances) of 11.36 kHz.

I recommend setting the function generator output for 1 volt, to make it easier for students to measure the point of "cutoff". You may set it at some other value, though, if you so choose (or let students set the value themselves when they test the circuit!).

For resistors, I recommend students choose three (3) resistors of equal value if they wish to build the Sallen-Key circuit with a Butterworth response (where  $R_2 = \frac{1}{2}R_1$ ). Resistor  $R_1$  will be a single resistor, while resistor  $R_2$  will be two resistors connected in parallel. This generally ensures a more precise 1:2 ratio than choosing individual components.

I also recommend having students use an oscilloscope to measure AC voltage in a circuit such as this, because some digital multimeters have difficulty accurately measuring AC voltage much beyond line frequency range. I find it particularly helpful to set the oscilloscope to the "X-Y" mode so that it draws a thin line on the screen rather than sweeps across the screen to show an actual waveform. This makes it easier to measure peak-to-peak voltage.

Values that have proven to work well for this exercise are given here, although of course many other values are possible:

- +V = +12 volts
- -V = -12 volts
- $R_1 = 10 \text{ k}\Omega$
- $R_2 = 5 \text{ k}\Omega$  (actually, two  $10 \text{ k}\Omega$  resistors in parallel)
- $R_{comp} = 10 \text{ k}\Omega$
- $C_1 = 0.002 \text{ }\mu\text{F}$  (actually, two  $0.001 \text{ }\mu\text{F}$  capacitors in parallel)
- $C_2 = 0.002 \text{ }\mu\text{F}$  (actually, two  $0.001 \text{ }\mu\text{F}$  capacitors in parallel)
- $U_1 =$  one-half of LM1458 dual operational amplifier

This combination of components gave a predicted cutoff frequency of 11.25 kHz, with an actual cutoff frequency (not factoring in component tolerances) of 11.11 kHz.

I also recommend having students use an oscilloscope to measure AC voltage in a circuit such as this, because some digital multimeters have difficulty accurately measuring AC voltage much beyond line frequency range. I find it particularly helpful to set the oscilloscope to the "X-Y" mode so that it draws a thin line on the screen rather than sweeps across the screen to show an actual waveform. This makes it easier to measure peak-to-peak voltage.

Values that have proven to work well for this exercise are given here, although of course many other values are possible:

- +V = +12 volts
- -V = -12 volts
- $R_1 = 10 \text{ k}\Omega$
- $R_2 = 10 \text{ k}\Omega$
- $R_3 = 5 \text{ k}\Omega$  (actually, two  $10 \text{ k}\Omega$  resistors in parallel)
- $R_4 = 100 \text{ k}\Omega$
- $C_1 = 0.001 \text{ }\mu\text{F}$
- $C_2 = 0.001 \text{ }\mu\text{F}$
- $C_3 = 0.002 \text{ }\mu\text{F}$  (actually, two  $0.001 \text{ }\mu\text{F}$  capacitors in parallel)
- $U_1 =$  one-half of LM1458 dual operational amplifier

This combination of components gave a predicted center frequency of 15.92 kHz, with an actual cutoff frequency (not factoring in component tolerances) of 15.63 kHz.

---

Notes 61

The purpose of this assessment rubric is to act as a sort of “contract” between you (the instructor) and your student. This way, the expectations are all clearly known in advance, which goes a long way toward disarming problems later when it is time to grade.

---

Notes 62

Determining the effect on resonant frequency is a simple matter of qualitative analysis with the resonant frequency formula. The effect on  $Q$  (challenge question) may be answered just as easily if the students know the formula relating bandwidth to  $L$ ,  $C$ , and  $R$ .

---

Notes 63

The follow-up question is yet another example of how practical the superposition theorem is when analyzing filter circuits.

---

Notes 64

The purpose of this question is to approach the domain of circuit troubleshooting from a perspective of knowing what the fault is, rather than only knowing what the symptoms are. Although this is not necessarily a realistic perspective, it helps students build the foundational knowledge necessary to diagnose a faulted circuit from empirical data. Questions such as this should be followed (eventually) by other questions asking students to identify likely faults based on measurements.

---

Notes 65

The purpose of this question is to approach the domain of circuit troubleshooting from a perspective of knowing what the fault is, rather than only knowing what the symptoms are. Although this is not necessarily a realistic perspective, it helps students build the foundational knowledge necessary to diagnose a faulted circuit from empirical data. Questions such as this should be followed (eventually) by other questions asking students to identify likely faults based on measurements.

---

Notes 66

The purpose of this question is to approach the domain of circuit troubleshooting from a perspective of knowing what the fault is, rather than only knowing what the symptoms are. Although this is not necessarily a realistic perspective, it helps students build the foundational knowledge necessary to diagnose a faulted circuit from empirical data. Questions such as this should be followed (eventually) by other questions asking students to identify likely faults based on measurements.

---

Notes 67

The purpose of this question is to approach the domain of circuit troubleshooting from a perspective of knowing what the fault is, rather than only knowing what the symptoms are. Although this is not necessarily a realistic perspective, it helps students build the foundational knowledge necessary to diagnose a faulted circuit from empirical data. Questions such as this should be followed (eventually) by other questions asking students to identify likely faults based on measurements.

---

Notes 68

The purpose of this question is to approach the domain of circuit troubleshooting from a perspective of knowing what the fault is, rather than only knowing what the symptoms are. Although this is not necessarily a realistic perspective, it helps students build the foundational knowledge necessary to diagnose a faulted circuit from empirical data. Questions such as this should be followed (eventually) by other questions asking students to identify likely faults based on measurements.

---

---

Notes 69

The purpose of this question is to approach the domain of circuit troubleshooting from a perspective of knowing what the fault is, rather than only knowing what the symptoms are. Although this is not necessarily a realistic perspective, it helps students build the foundational knowledge necessary to diagnose a faulted circuit from empirical data. Questions such as this should be followed (eventually) by other questions asking students to identify likely faults based on measurements.

---

Notes 70

Ask your students to explain how they identified their proposed faults, and also how they were able to identify component that *must* still be working properly.

---

Notes 71

Ask your students to explain how they identified their proposed faults, and also how they were able to identify component that *must* still be working properly.

---

Notes 72

This question provides good review of fundamental capacitor behavior, and also explains *why* opamps have slow rates as they do.

---

Notes 73

Ask your students to explain what the words "hypotenuse", "opposite", and "adjacent" refer to in a right triangle.

---

Notes 74

Ask your students to explain what the words "hypotenuse", "opposite", and "adjacent" refer to in a right triangle.

---

Notes 75

The question is sufficiently open-ended that many students may not realize exactly what is being asked until they read the answer. This is okay, as it is difficult to phrase the question in a more specific manner without giving away the answer!

---

Notes 76

Trying to apply the  $Z$ - $R$ - $X$  triangle directly to parallel AC circuits is a common mistake many new students make. Key to knowing when and how to use triangles to graphically depict AC quantities is understanding *why* the triangle works as an analysis tool and *what* its sides represent.

---

Notes 77

This question asks students to identify those variables in each circuit that vectorially *add*, discriminating them from those variables which do not add. This is extremely important for students to be able to do if they are to successfully apply "the triangle" to the solution of AC circuit problems.

Note that some of these triangles should be drawn upside-down instead of all the same as they are shown in the question, if we are to properly represent the vertical (imaginary) phasor for capacitive impedance and for inductor admittance. However, the point here is simply to get students to recognize what quantities add and what do not. Attention to the direction (up or down) of the triangle's opposite side can come later.

---

Notes 78

Be sure to have students show you the form of the Pythagorean Theorem, rather than showing them yourself, since it is so easy for students to research on their own.

---

Notes 79

Ask your students to show you their algebraic manipulation(s) in setting up the equation for evaluation.

---

Notes 80

There are a few different ways one could solve for  $R$  and  $X$  in this trigonometry problem. This would be a good opportunity to have your students present problem-solving strategies on the board in front of class so everyone gets an opportunity to see multiple techniques.

---

Notes 81

The follow-up question illustrates an important principle in many different disciplines: avoidance of unnecessary risk by choosing calculation techniques using given quantities instead of derived quantities. This is a good topic to discuss with your students, so make sure you do so.

---

Notes 82

Ask your students to explain their method(s) of solution, including any ways to double-check the correctness of the answer.

---

Notes 83

The most important thing to be learned here is that the opamp "isolates" the signal source from whatever impedance is in the feedback loop, so that the input impedance (in this case, the 10 k $\Omega$  resistor) is the only impedance "visible" to that source. This has profound effects on the phase relationship between the output signal and the input signal.

---

Notes 84

The most important thing to be learned here is that the opamp "isolates" the signal source from whatever impedance is in the feedback loop, so that the input impedance (in this case, the 10 k $\Omega$  resistor) is the only impedance "visible" to that source. This has profound effects on the phase relationship between the output signal and the input signal.

---

Notes 85

The plot given in the answer, of course, is for an ideal high-pass filter, where all frequencies below  $f_{cutoff}$  are blocked and all frequencies above  $f_{cutoff}$  are passed. In reality, filter circuits never attain this ideal "square-edge" response. Discuss possible applications of such a filter with your students.

Challenge them to draw the Bode plots for ideal *band-pass* and *band-stop* filters as well. Exercises such as this really help to clarify the purpose of filter circuits. Otherwise, there is a tendency to lose perspective of what real filter circuits, with their correspondingly complex Bode plots and mathematical analyses, are supposed to do.

---

Notes 86

The plot given in the answer, of course, is for an ideal low-pass filter, where all frequencies below  $f_{cutoff}$  are passed and all frequencies above  $f_{cutoff}$  are blocked. In reality, filter circuits never attain this ideal "square-edge" response. Discuss possible applications of such a filter with your students.

Challenge them to draw the Bode plots for ideal *band-pass* and *band-stop* filters as well. Exercises such as this really help to clarify the purpose of filter circuits. Otherwise, there is a tendency to lose perspective of what real filter circuits, with their correspondingly complex Bode plots and mathematical analyses, are supposed to do.

---

---

Notes 87

Ask your students to describe what type of filter circuit a series-connected capacitor forms: low-pass, high-pass, band-pass, or band-stop? Discuss how the name of this filter should describe its intended function in the sound system.

Regarding the follow-up question, it is important for students to recognize the practical limitations of certain capacitor types. One thing is for sure, ordinary (polarized) electrolytic capacitors will not function properly in an application like this!

---

Notes 88

Discuss with your students why inductors were chosen as filtering elements for the DC power, while capacitors were chosen as filtering elements for the AC data signals. What are the relative reactances of these components when subjected to the respective frequencies of the AC data signals (many kilohertz or megahertz) versus the DC power supply (frequency = 0 hertz).

This question is also a good review of the "superposition theorem," one of the most useful and easiest-to-understand of the network theorems. Note that no quantitative values need be considered to grasp the function of this communications network. Analyze it *qualitatively* with your students instead.

---

Notes 89

The most important part of this question, as usual, is to have students come up with methods of solution for determining R's value. Ask them to explain how they arrived at their answer, and if their method of solution made use of any formula or principle used in *capacitive* filter circuits.

---

Notes 90

As usual, ask your students to explain *why* the answer is correct, not just repeat the answer that is given!

---

Notes 91

As usual, ask your students to explain *why* the answer is correct, not just repeat the answer that is given!

---

Notes 92

The purpose of this question, besides providing a convenient way to characterize a filter circuit, is to introduce students to the concept of a *white noise source* and also to strengthen their understanding of a spectrum analyzer's function.

In case anyone happens to notice, be aware that the rolloff shown for this filter circuit is *very* steep! This sort of sharp response could never be realized with a simple one-resistor, one-capacitor ("first order") filter. It would have to be a multi-stage analog filter circuit or some sort of active filter circuit.