

Questions

Question 1

Animation: Johnson ring counter

This question consists of a series of images (one per page) that form an animation. Flip the pages with your fingers to view this animation (or click on the "next" button on your viewer) frame-by-frame.

The following animation shows a 4-bit Johnson ring counter circuit. Watch what happens as the clock signal oscillates. Here are some things to look for:

- Note when the logic state at each flip-flop input gets sent to the Q output.
- Why do you think this is called a "ring" counter circuit?

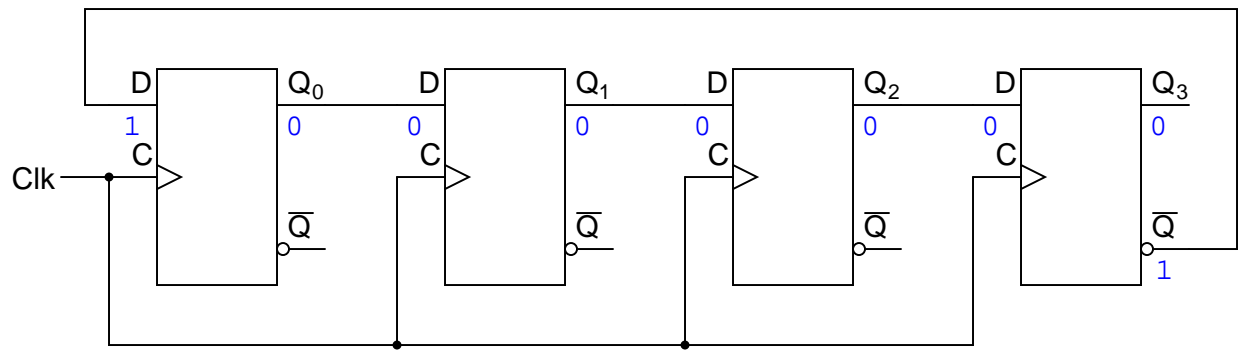

Clock

Q_0

Q_1

Q_2

Q_3

V_{DD}

Gnd

V_{DD}

Gnd

V_{DD}

Gnd

V_{DD}

Gnd

V_{DD}

Gnd

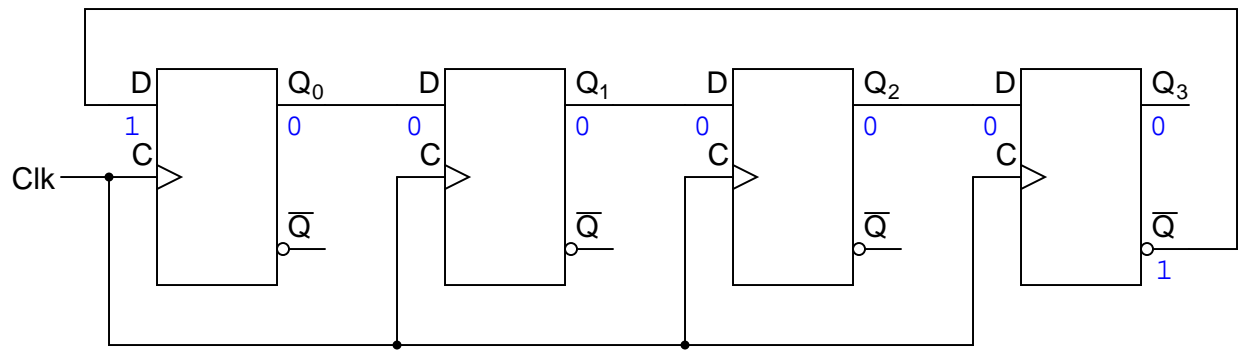

Clock

V_{DD}

Gnd

Q₀

V_{DD}

Gnd

Q₁

V_{DD}

Gnd

Q₂

V_{DD}

Gnd

Q₃

V_{DD}

Gnd

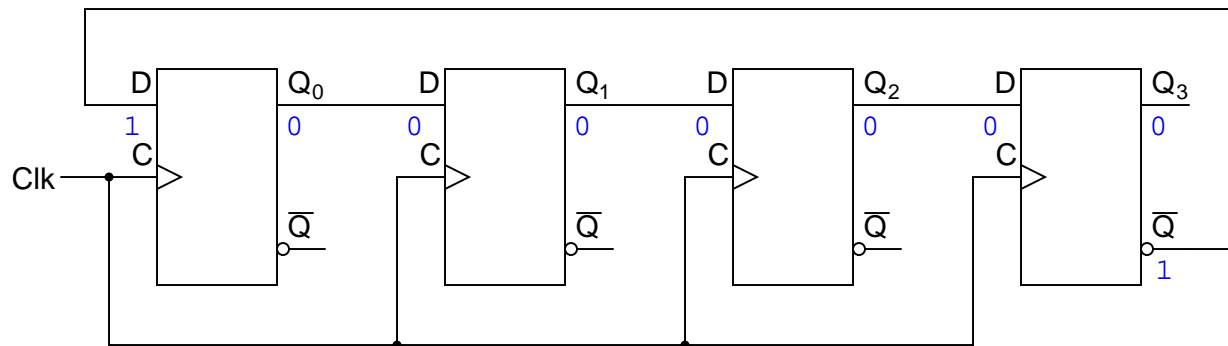

Clock

Q₀

Q₁

Q₂

Q₃

V_{DD}

Gnd

V_{DD}

Gnd

V_{DD}

Gnd

V_{DD}

Gnd

V_{DD}

Gnd

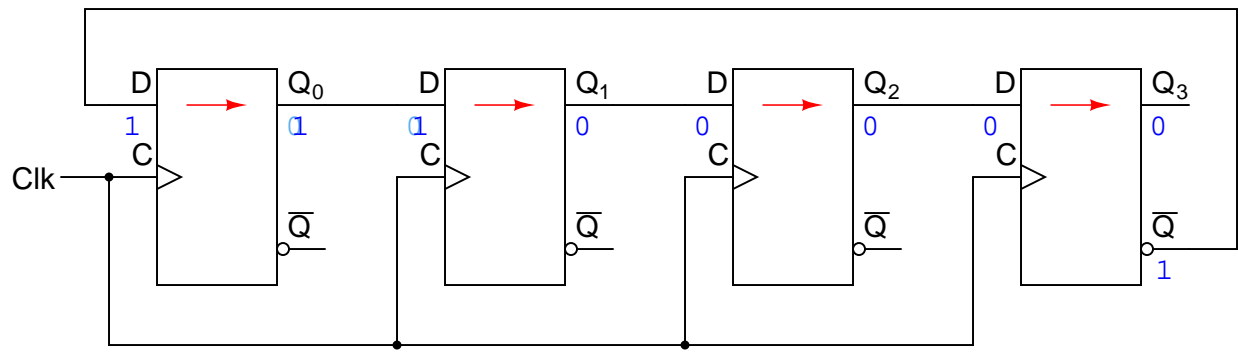

Clock

Q₀

Q₁

Q₂

Q₃

V_{DD}

Gnd

V_{DD}

Gnd

V_{DD}

Gnd

V_{DD}

Gnd

V_{DD}

Gnd

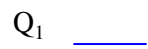
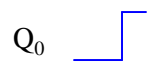
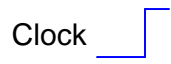
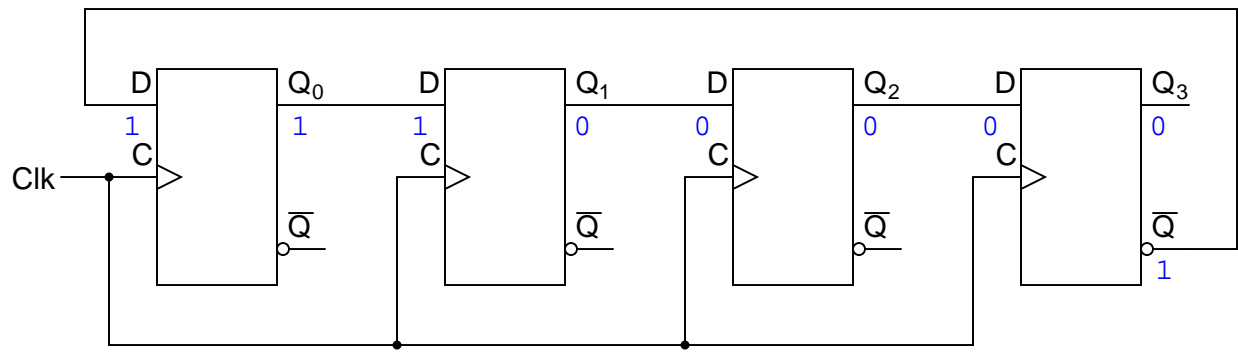

V_{DD}

Gnd

V_{DD}

Gnd

V_{DD}

Gnd

V_{DD}

Gnd

V_{DD}

Gnd

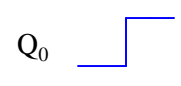
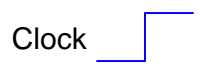
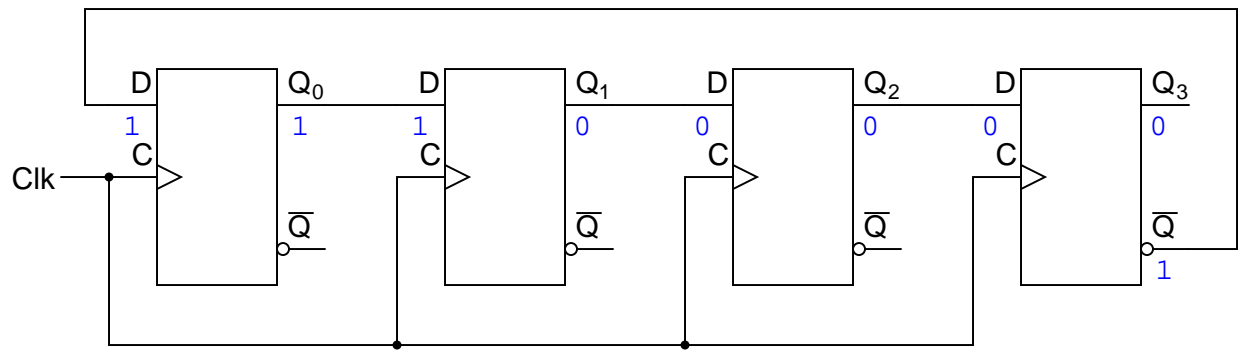

V_{DD}

Gnd

V_{DD}

Gnd

V_{DD}

Gnd

V_{DD}

Gnd

V_{DD}

Gnd

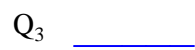
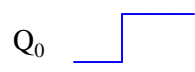
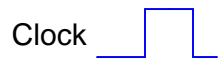
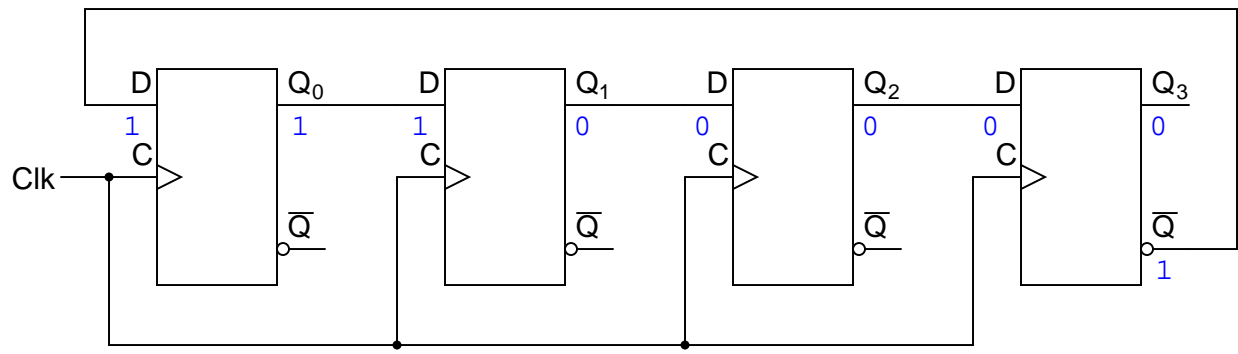

V_{DD}

Gnd

V_{DD}

Gnd

V_{DD}

Gnd

V_{DD}

Gnd

V_{DD}

Gnd

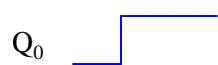
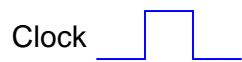
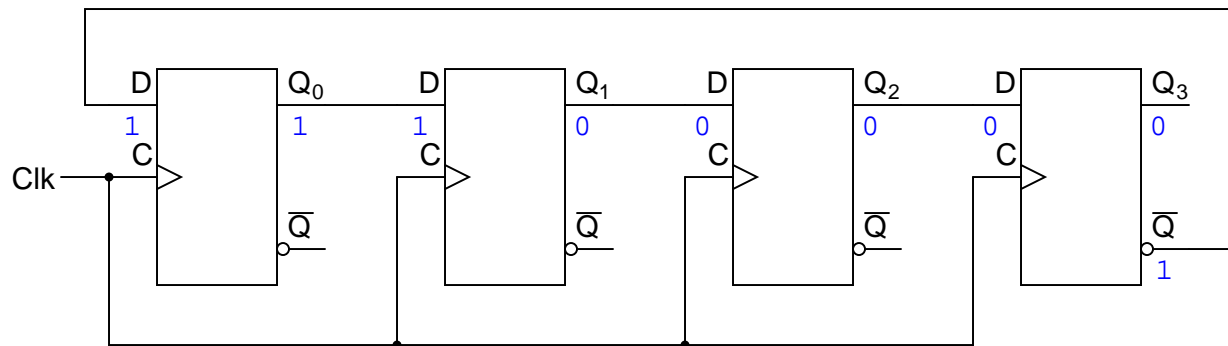

V_{DD}

Gnd

V_{DD}

Gnd

V_{DD}

Gnd

V_{DD}

Gnd

V_{DD}

Gnd

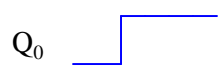
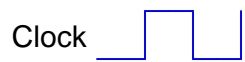
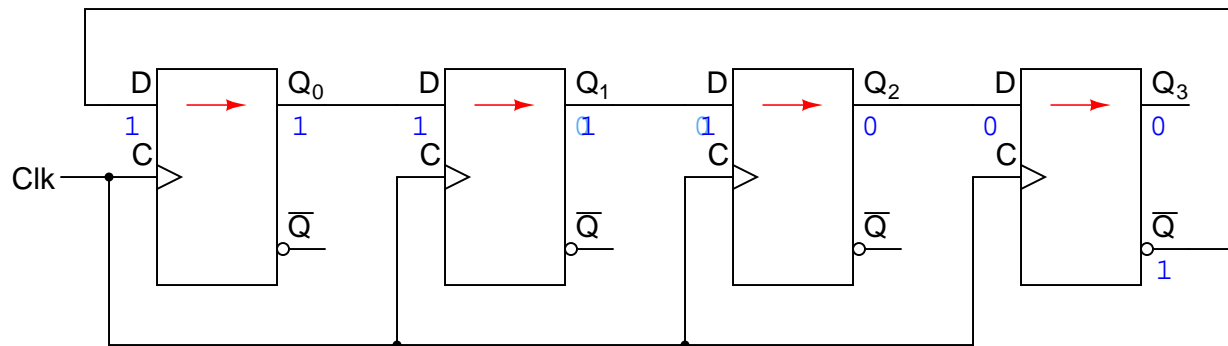

V_{DD}

Gnd

V_{DD}

Gnd

V_{DD}

Gnd

V_{DD}

Gnd

V_{DD}

Gnd

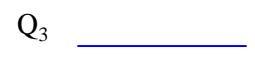
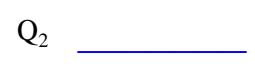
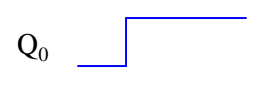
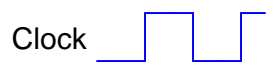
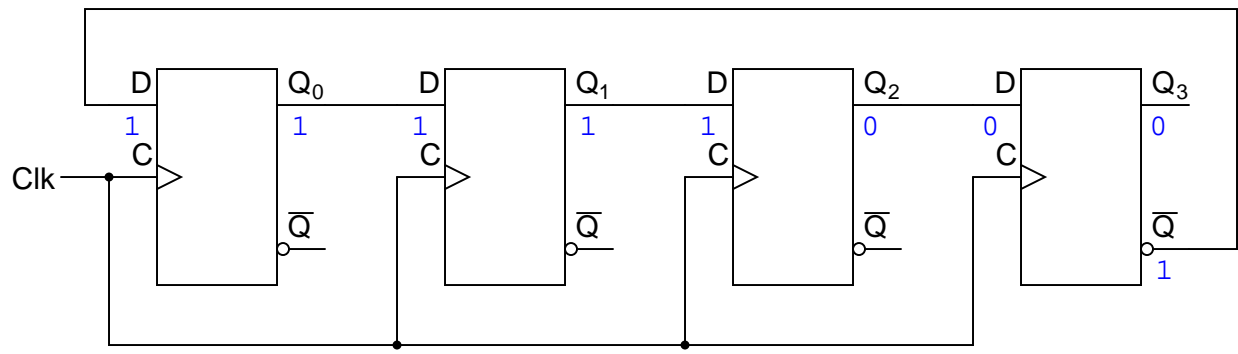

V_{DD}

Gnd

V_{DD}

Gnd

V_{DD}

Gnd

V_{DD}

Gnd

V_{DD}

Gnd

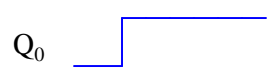
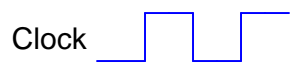
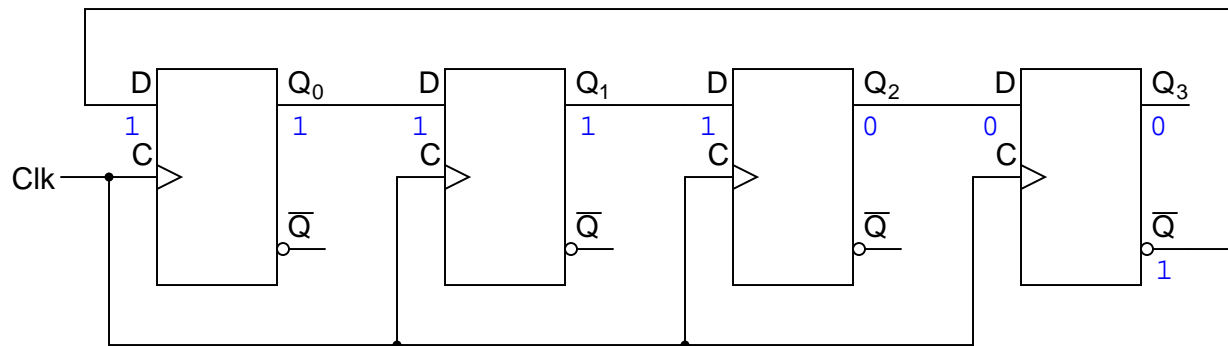

V_{DD}

Gnd

V_{DD}

Gnd

V_{DD}

Gnd

V_{DD}

Gnd

V_{DD}

Gnd

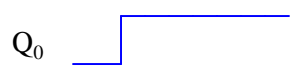
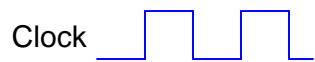
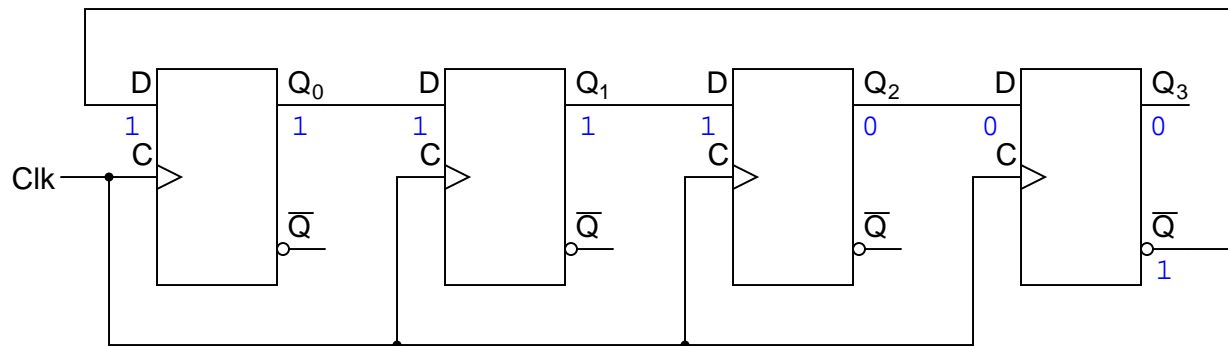

V_{DD}

Gnd

V_{DD}

Gnd

V_{DD}

Gnd

V_{DD}

Gnd

V_{DD}

Gnd

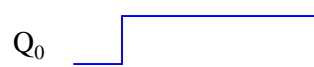
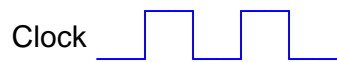
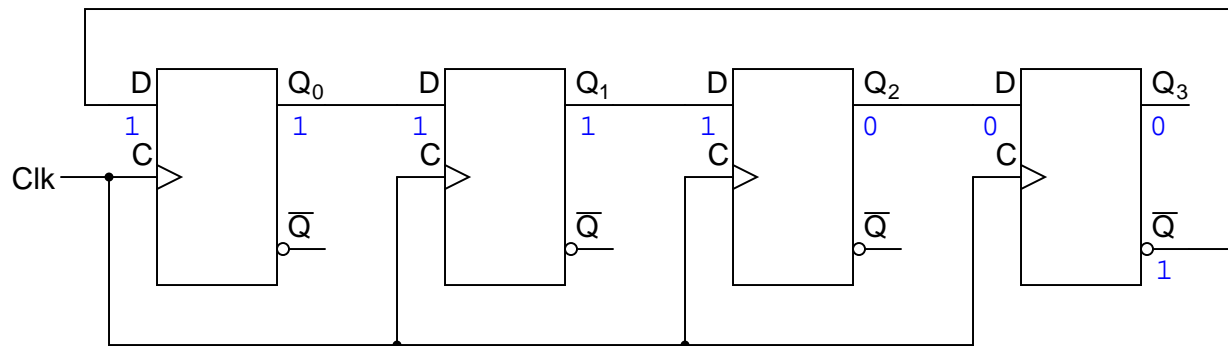

V_{DD}

Gnd

V_{DD}

Gnd

V_{DD}

Gnd

V_{DD}

Gnd

V_{DD}

Gnd

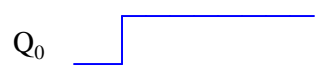
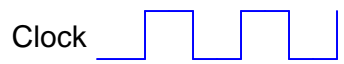
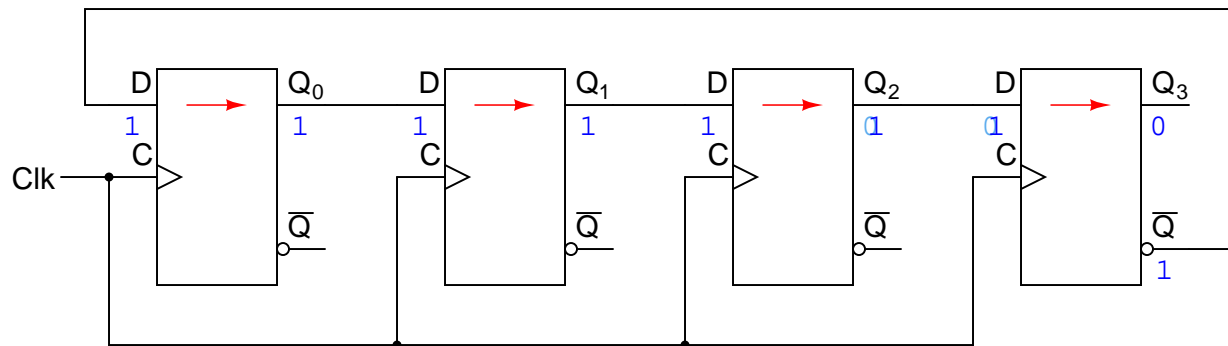

V_{DD}

Gnd

V_{DD}

Gnd

V_{DD}

Gnd

V_{DD}

Gnd

V_{DD}

Gnd

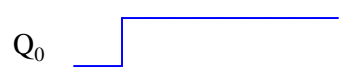
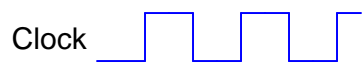
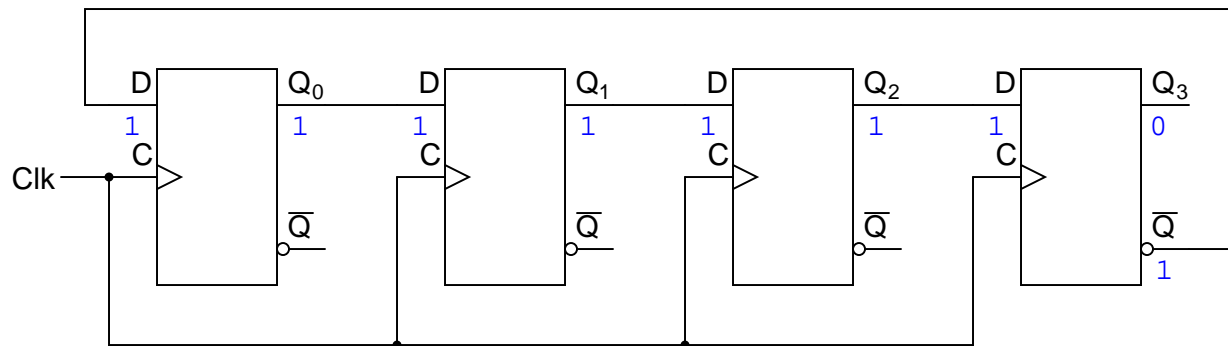

V_{DD}

Gnd

V_{DD}

Gnd

V_{DD}

Gnd

V_{DD}

Gnd

V_{DD}

Gnd

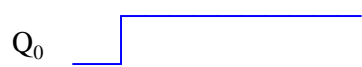
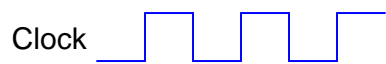
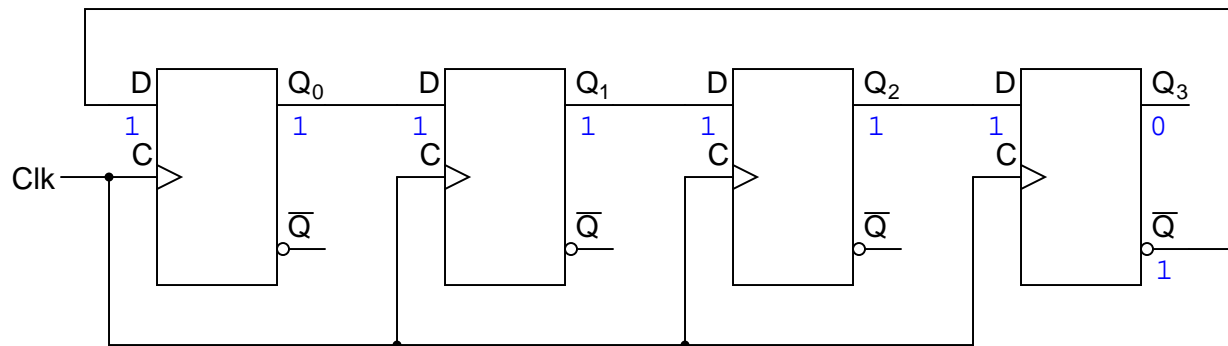

V_{DD}

Gnd

V_{DD}

Gnd

V_{DD}

Gnd

V_{DD}

Gnd

V_{DD}

Gnd

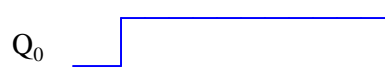
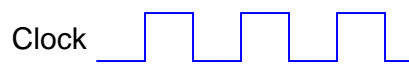
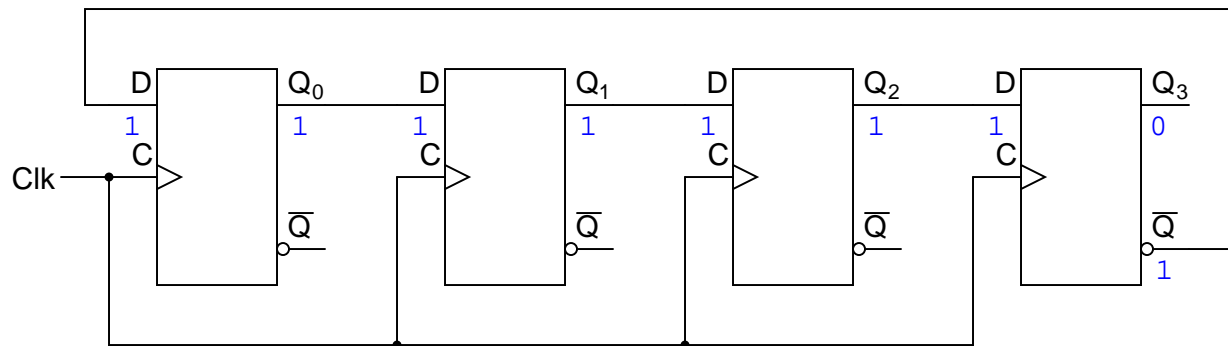

V_{DD}

Gnd

V_{DD}

Gnd

V_{DD}

Gnd

V_{DD}

Gnd

V_{DD}

Gnd

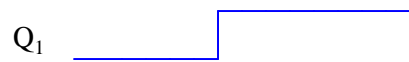
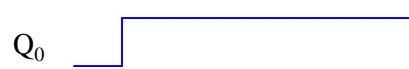
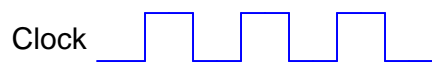
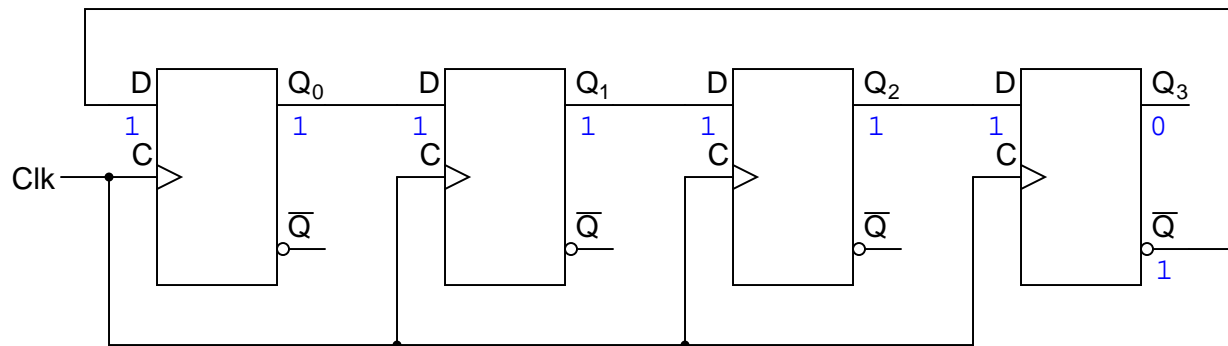

V_{DD}

Gnd

V_{DD}

Gnd

V_{DD}

Gnd

V_{DD}

Gnd

V_{DD}

Gnd

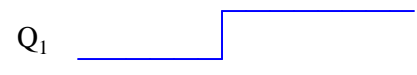
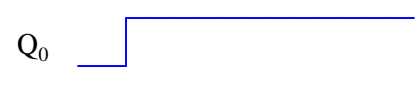
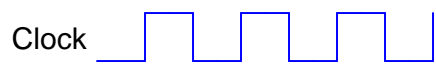
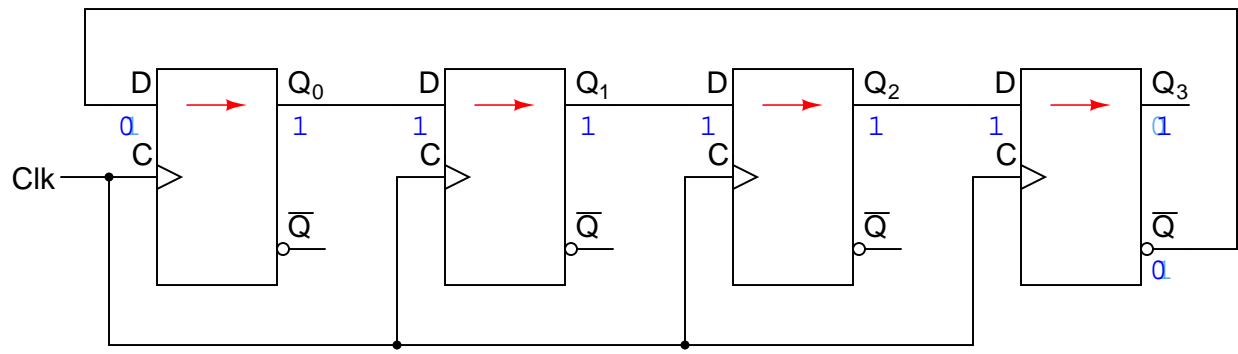

V_{DD}

Gnd

V_{DD}

Gnd

V_{DD}

Gnd

V_{DD}

Gnd

V_{DD}

Gnd

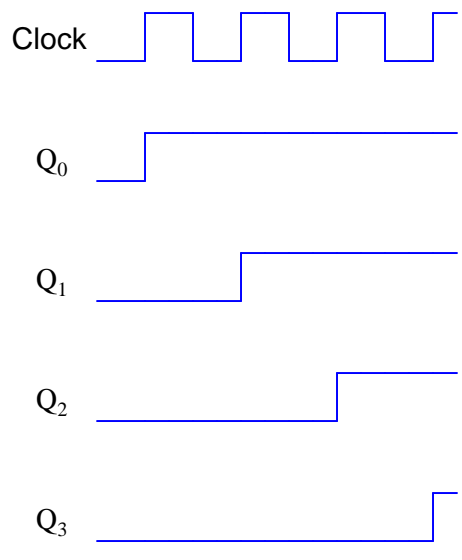
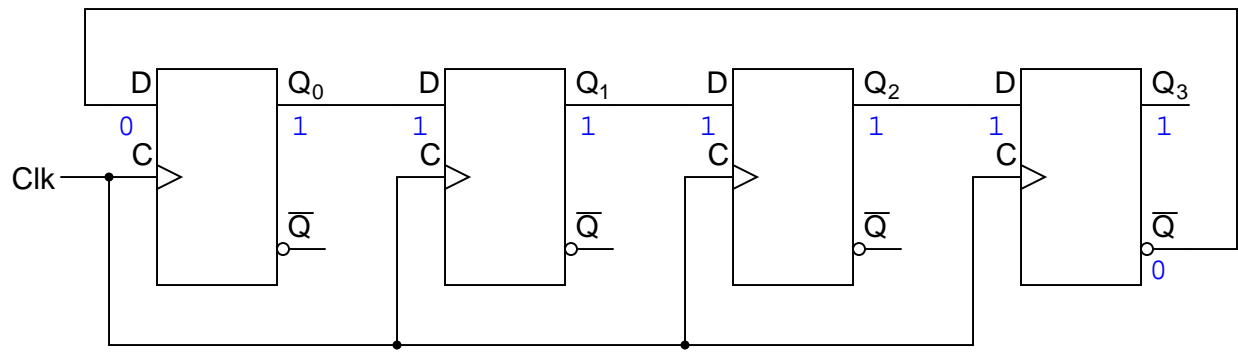

V_{DD}
 Gnd
 V_{DD}
 Gnd
 V_{DD}
 Gnd
 V_{DD}
 Gnd

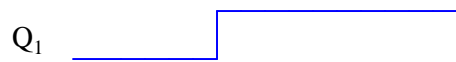
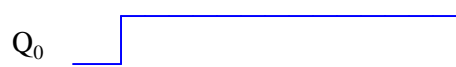
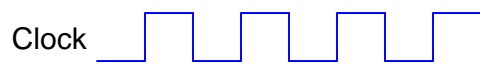
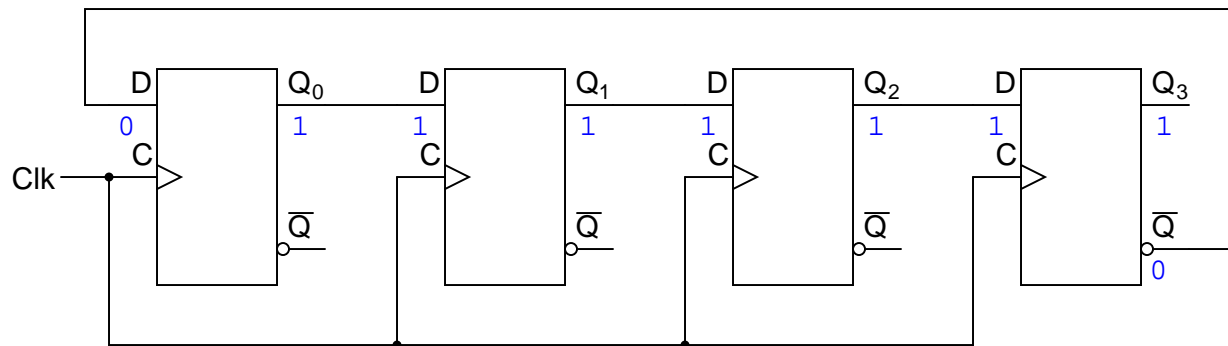

V_{DD}

Gnd

V_{DD}

Gnd

V_{DD}

Gnd

V_{DD}

Gnd

V_{DD}

Gnd

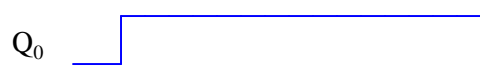
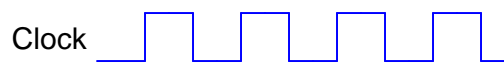
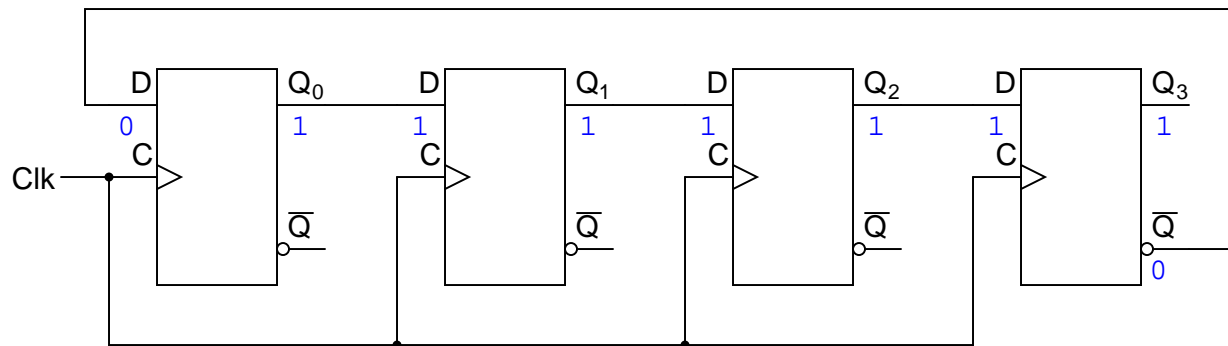

V_{DD}

Gnd

V_{DD}

Gnd

V_{DD}

Gnd

V_{DD}

Gnd

V_{DD}

Gnd

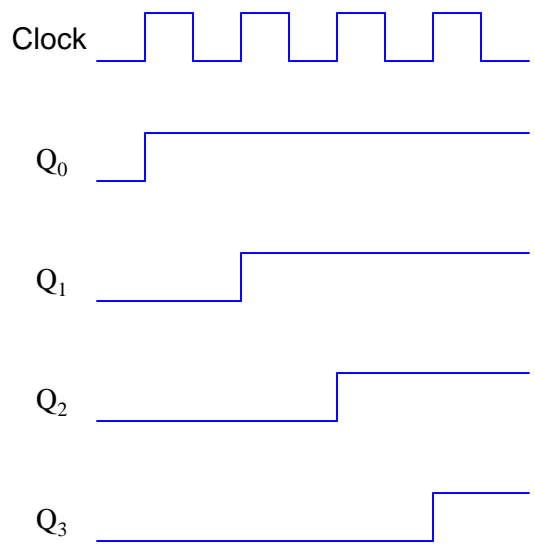
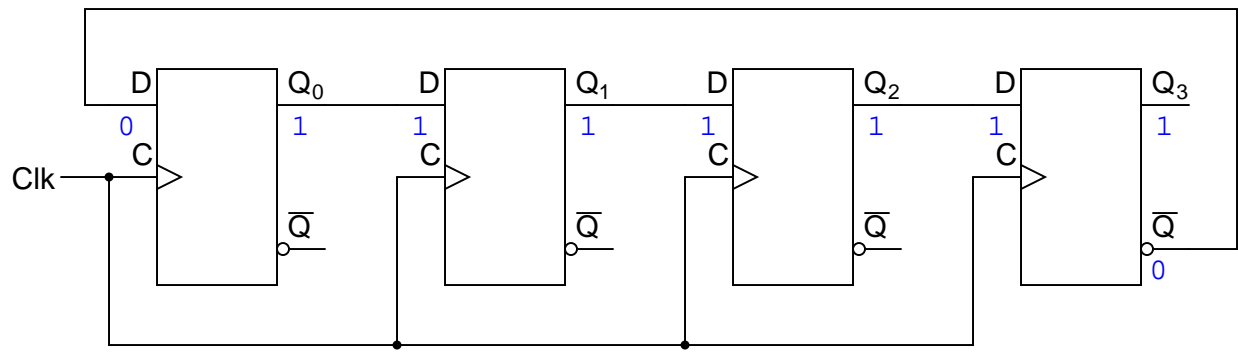

V_{DD}
 Gnd
 V_{DD}
 Gnd
 V_{DD}
 Gnd
 V_{DD}
 Gnd

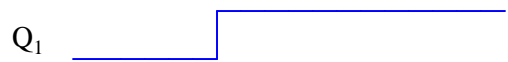
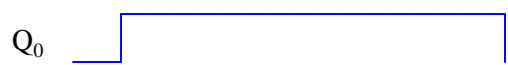
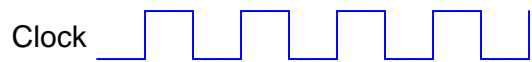
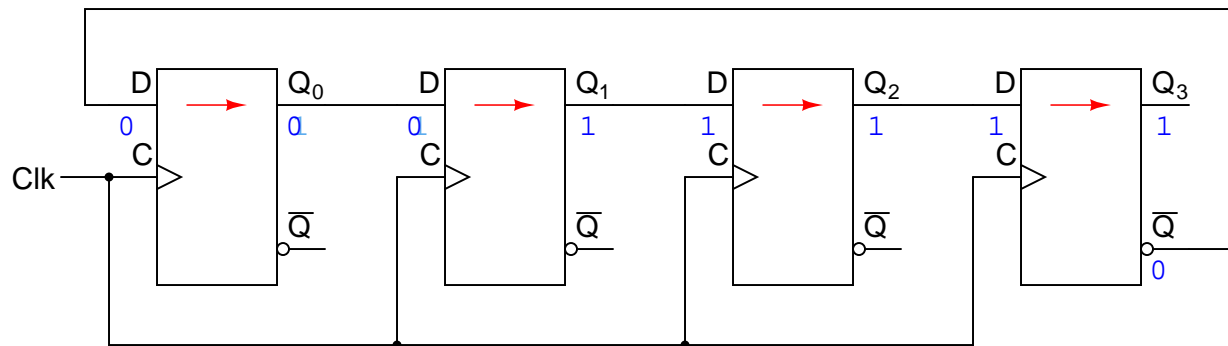

V_{DD}

Gnd

V_{DD}

Gnd

V_{DD}

Gnd

V_{DD}

Gnd

V_{DD}

Gnd

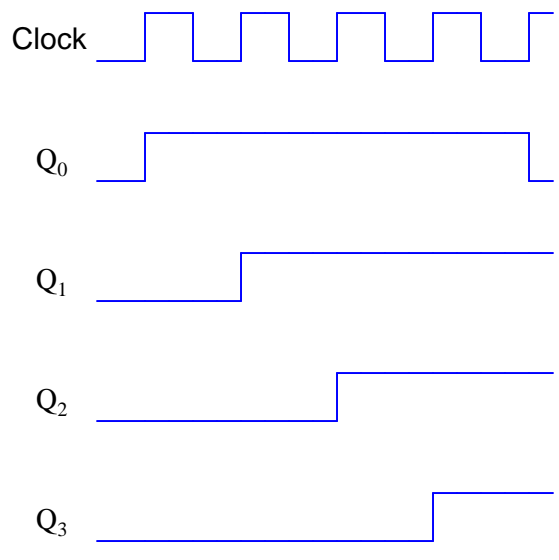
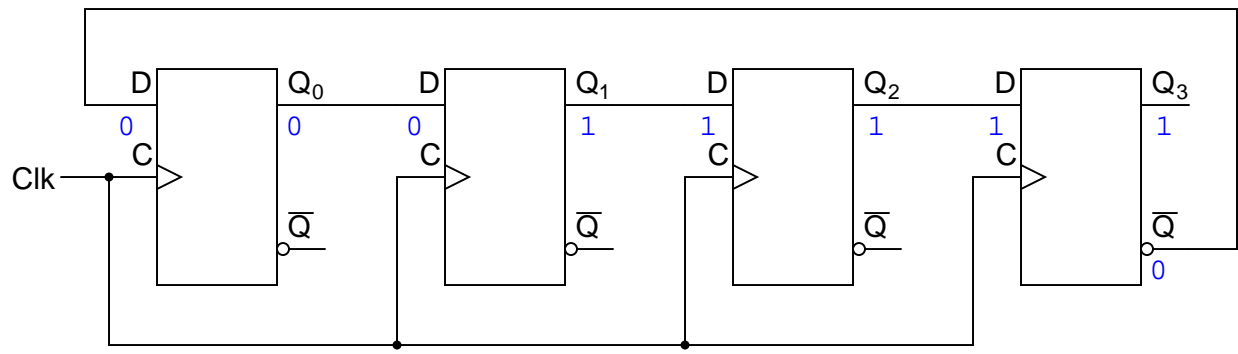

V_{DD}
Gnd
V_{DD}
Gnd
V_{DD}
Gnd
V_{DD}
Gnd

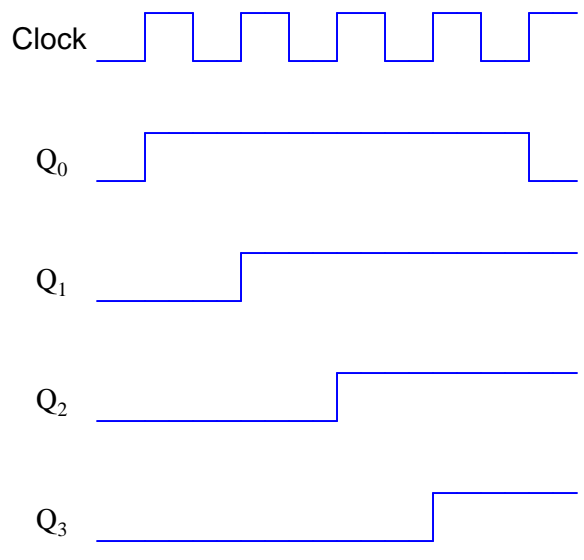
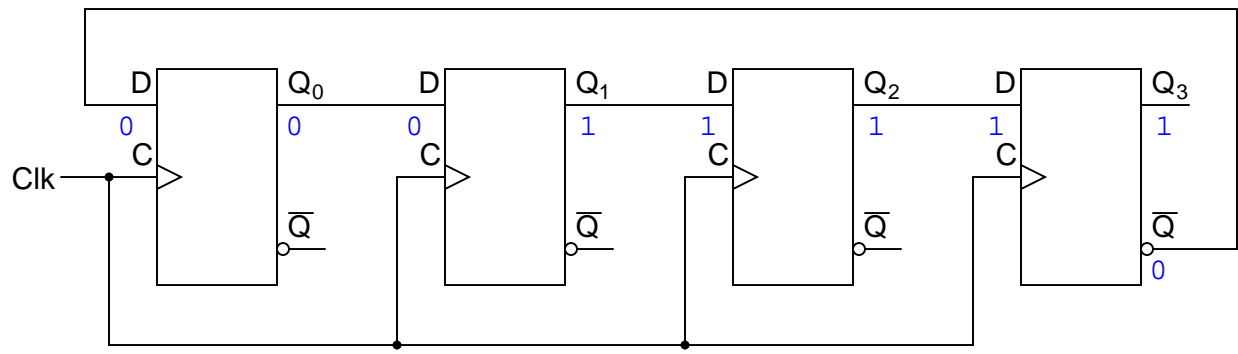

V_{DD}
Gnd
V_{DD}
Gnd
V_{DD}
Gnd
V_{DD}
Gnd

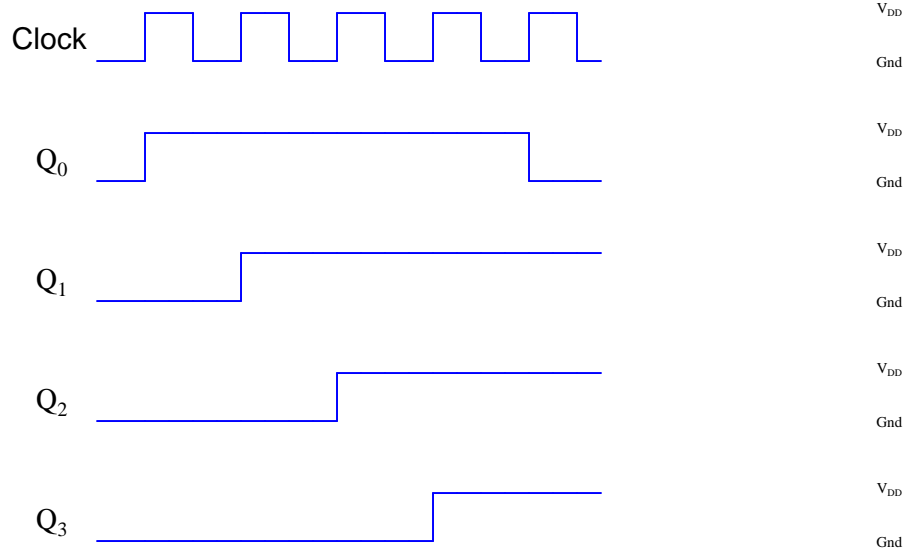
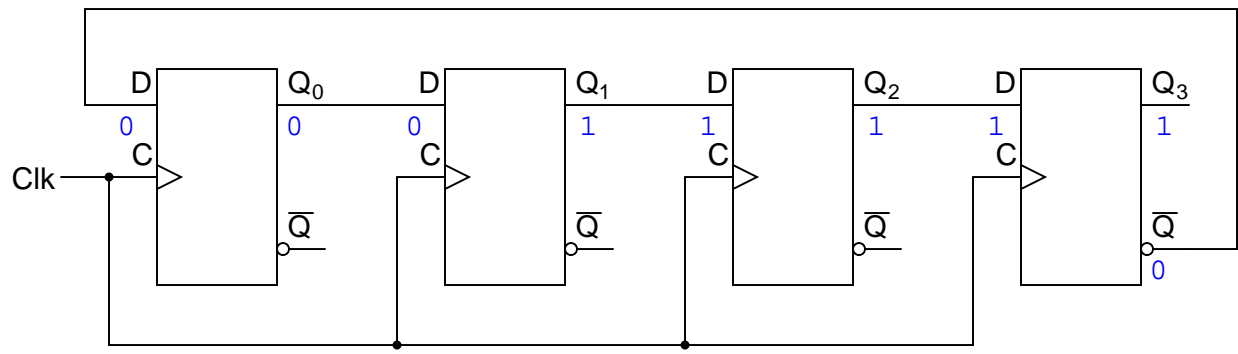

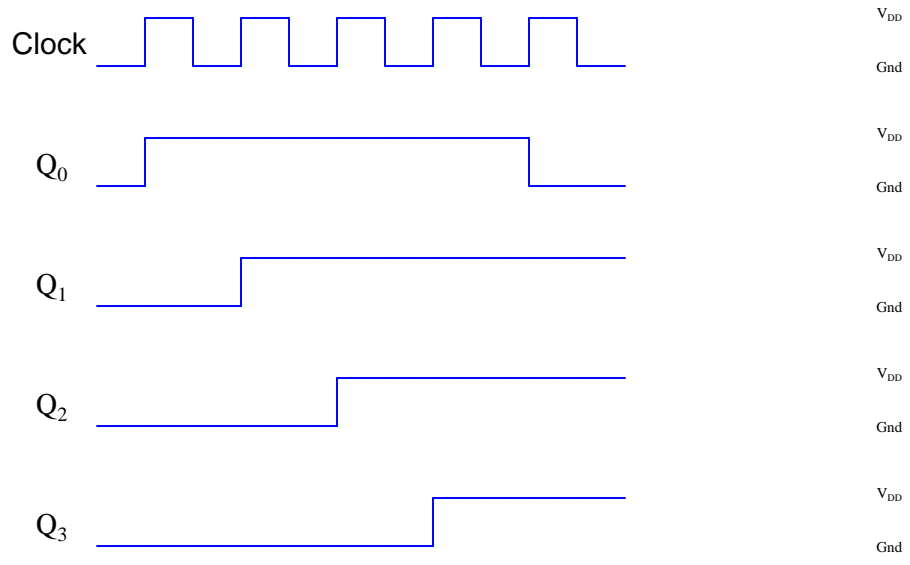
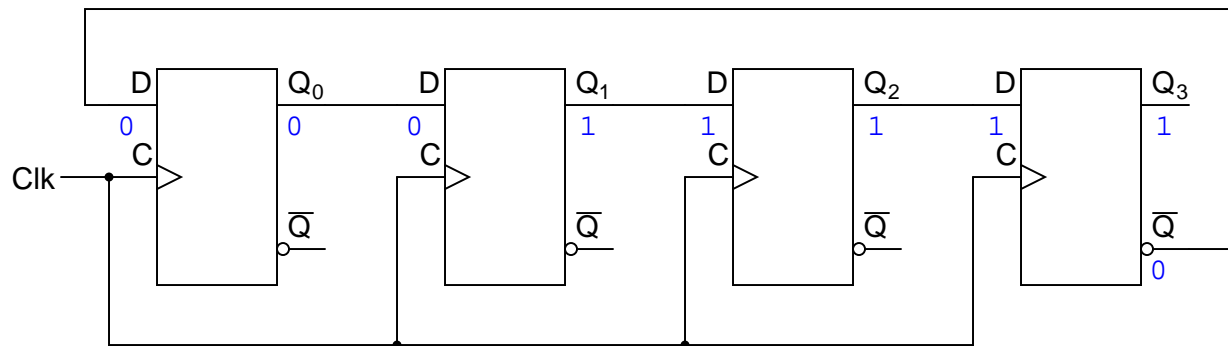

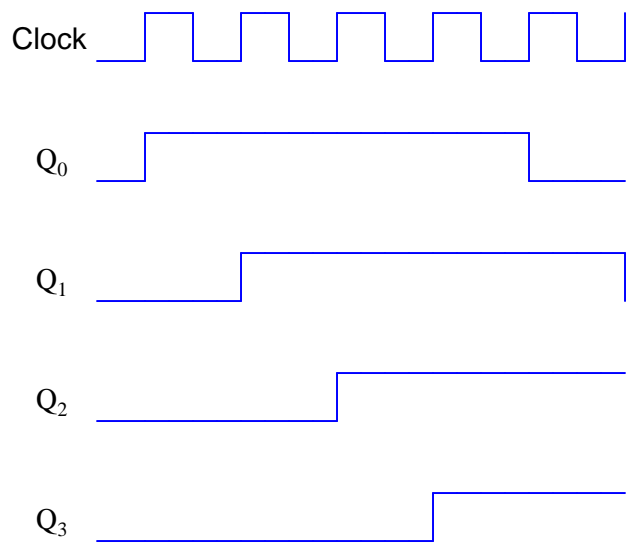
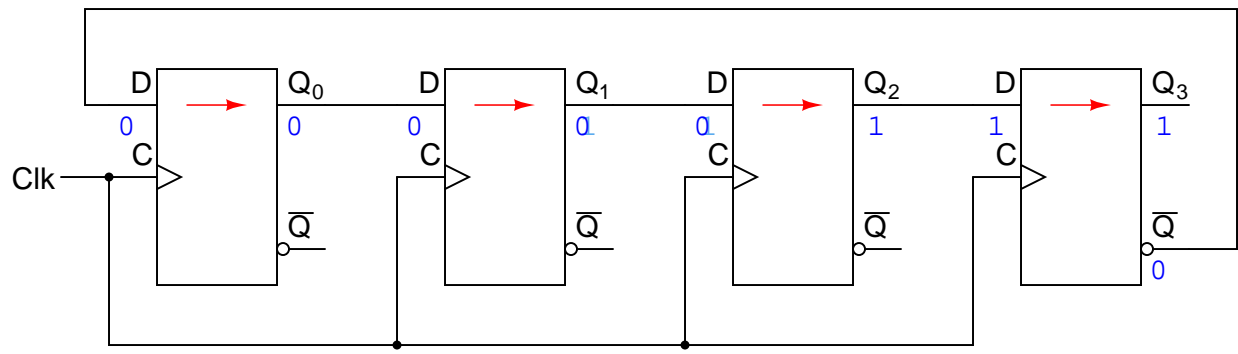

V_{DD}
Gnd
V_{DD}
Gnd
V_{DD}
Gnd
V_{DD}
Gnd

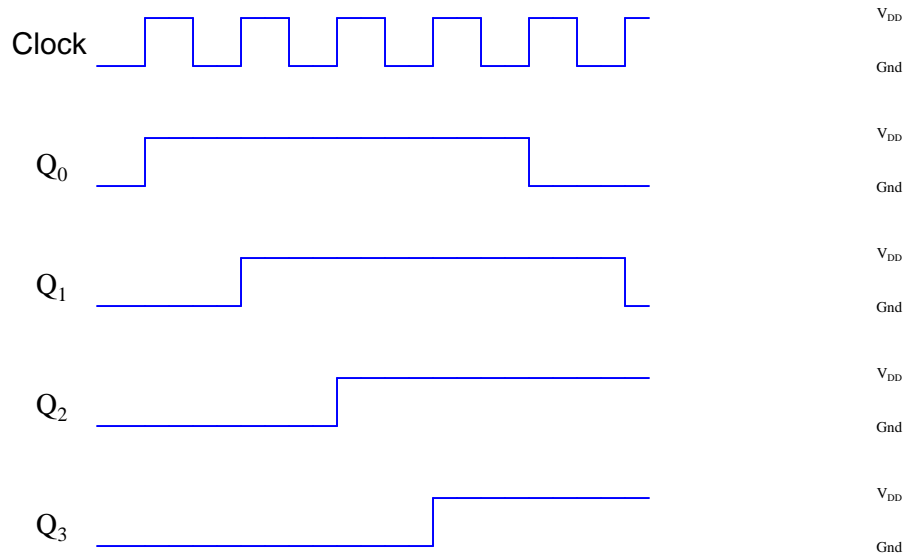
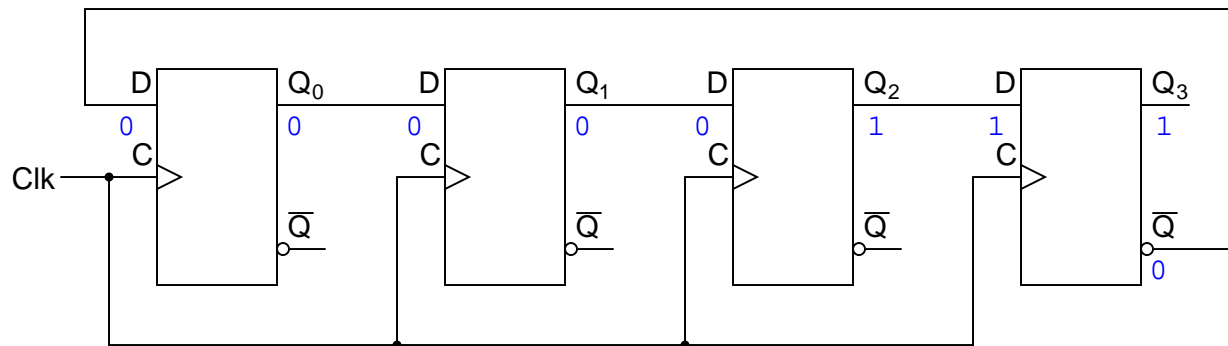

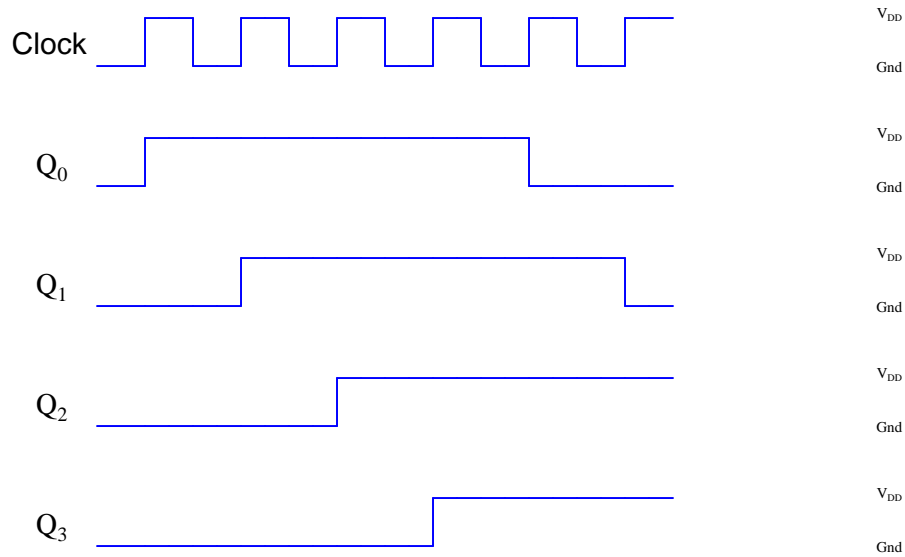
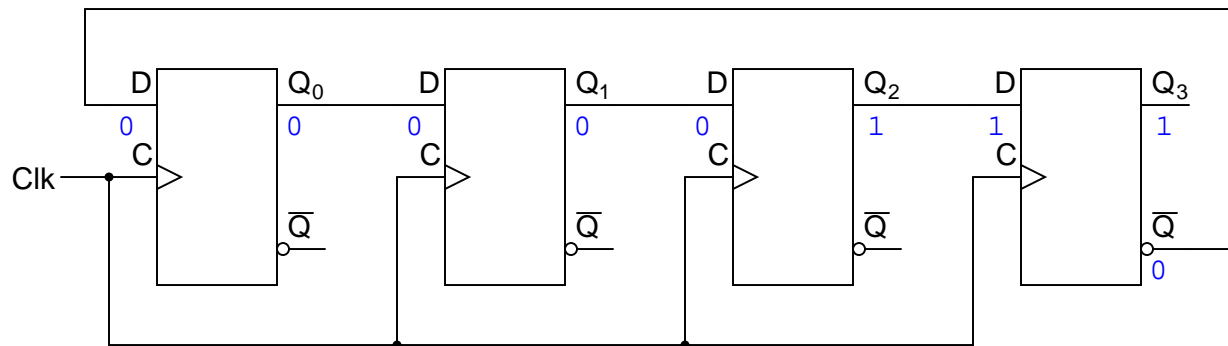

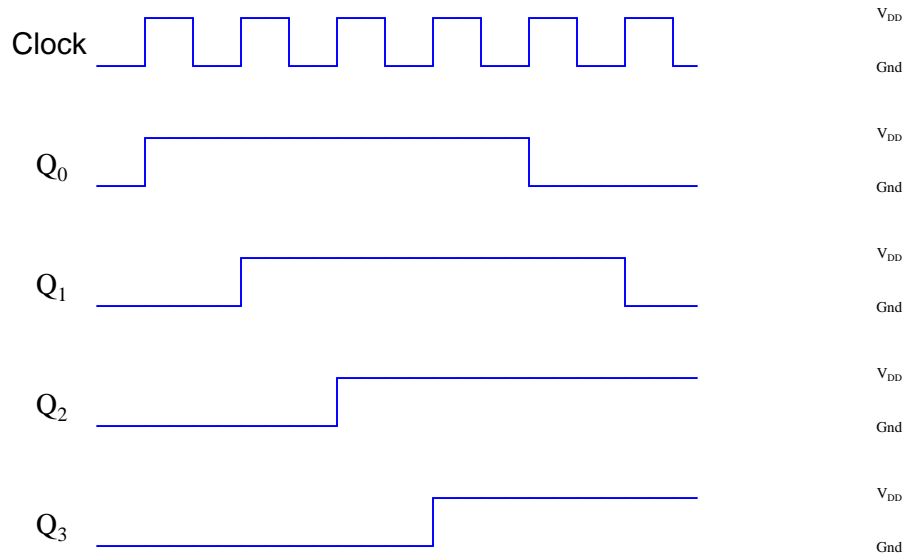
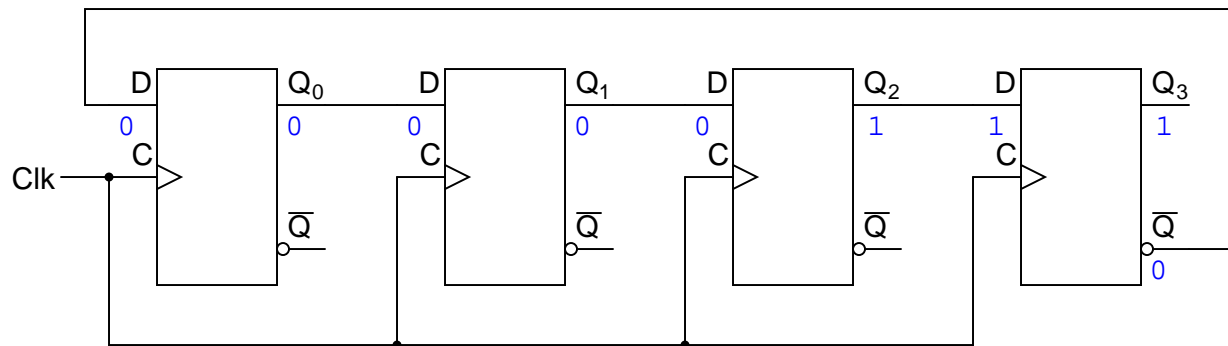

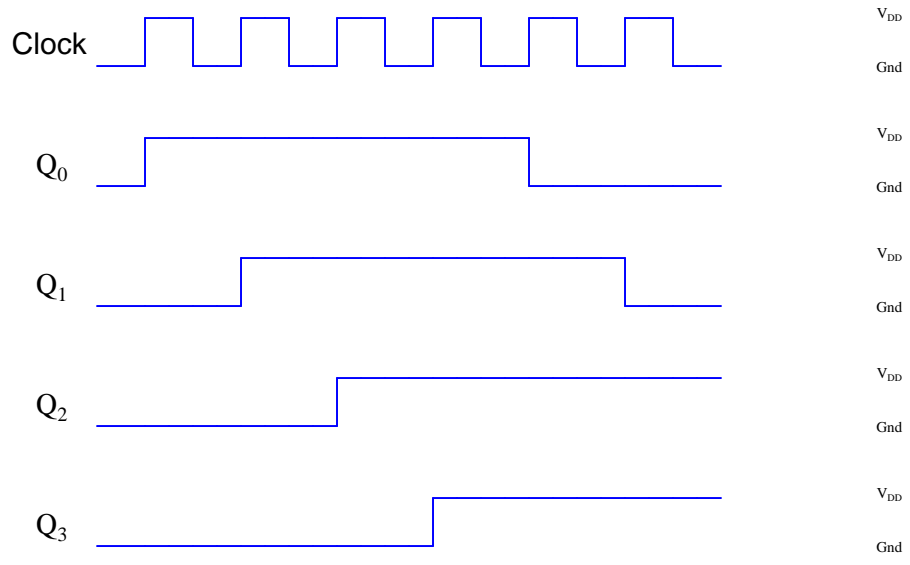
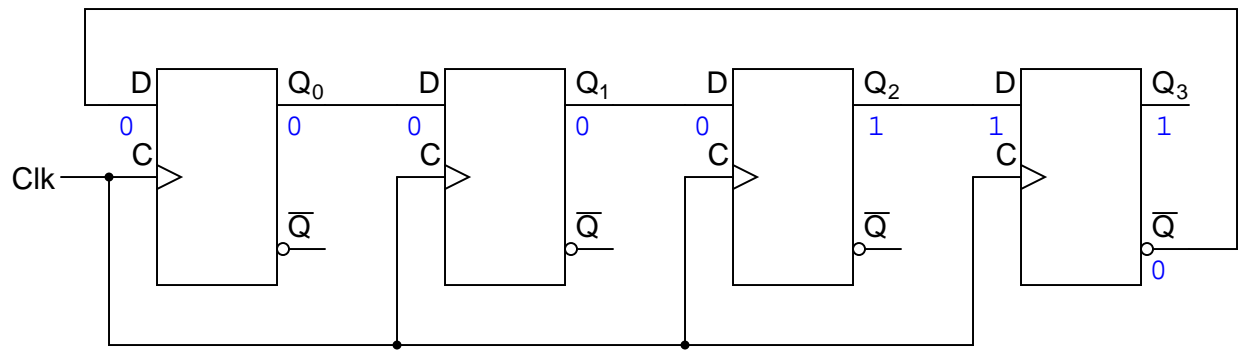

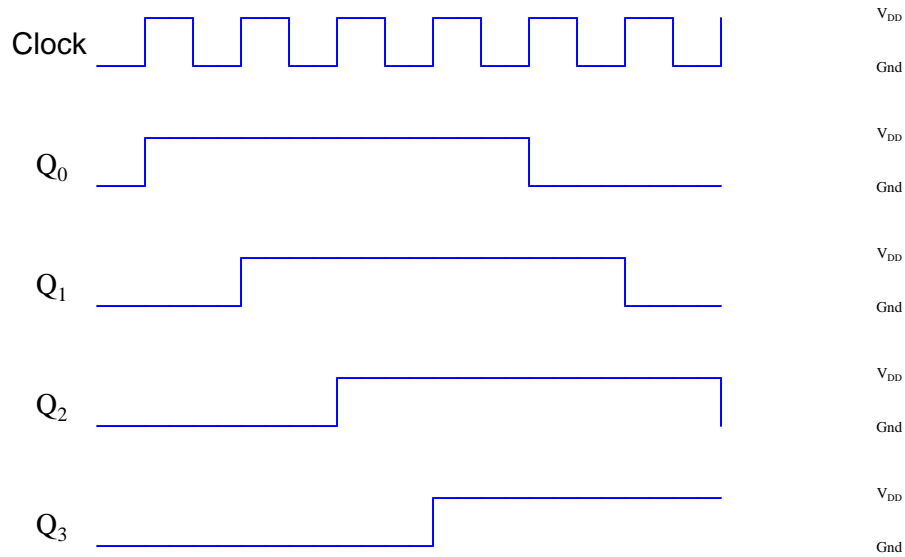
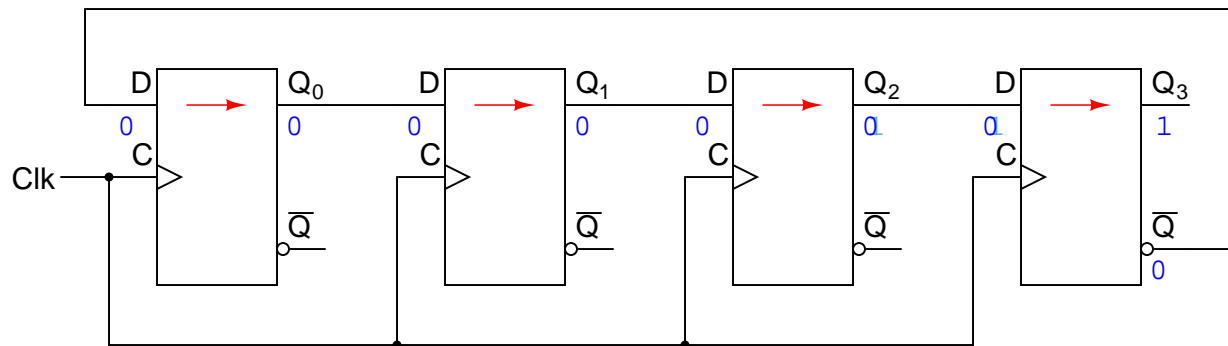

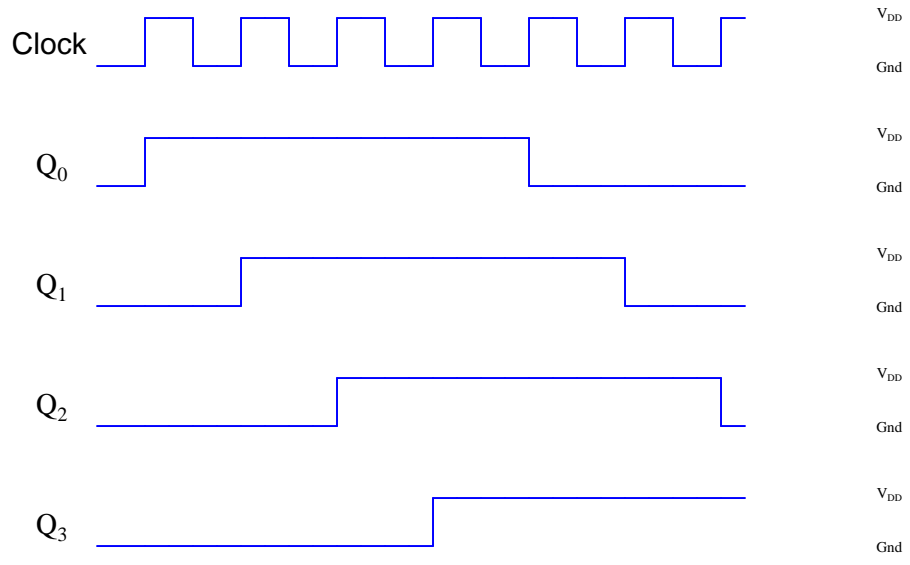
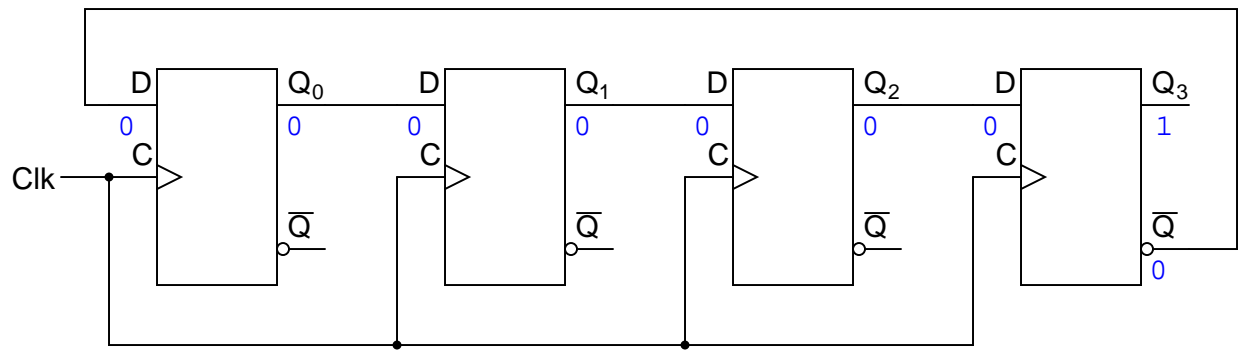

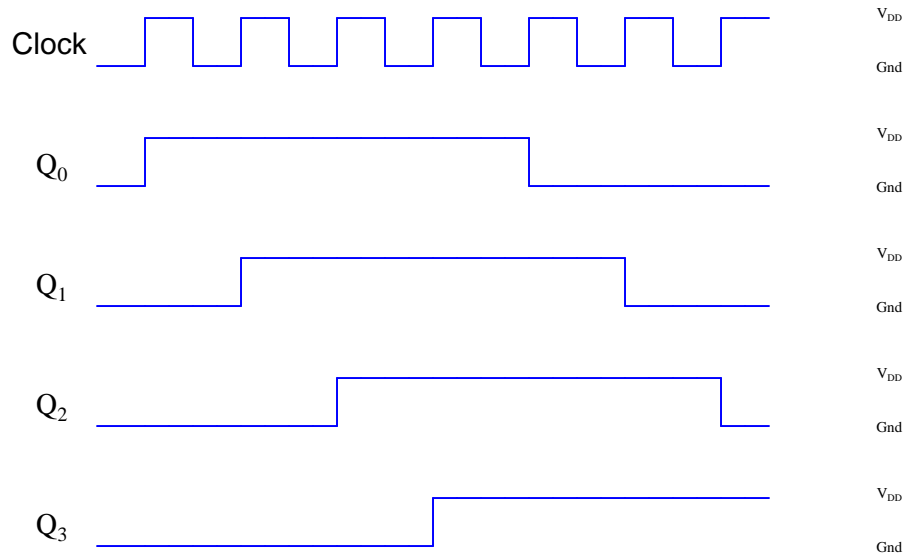
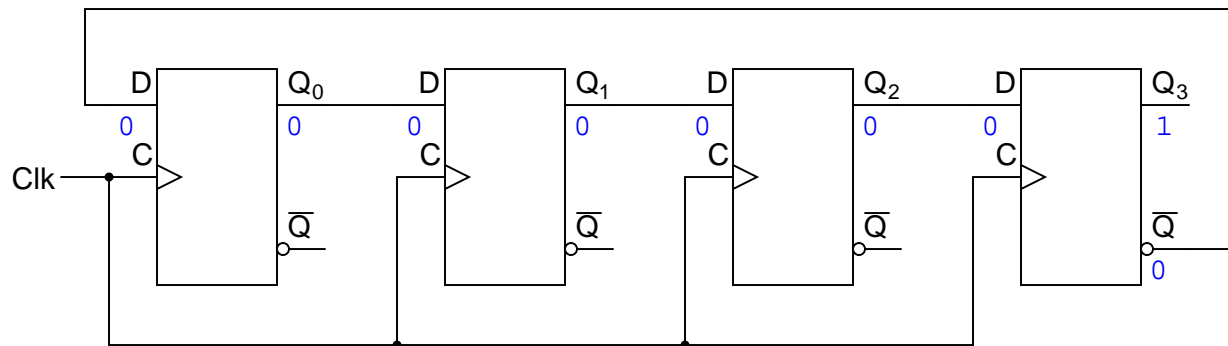

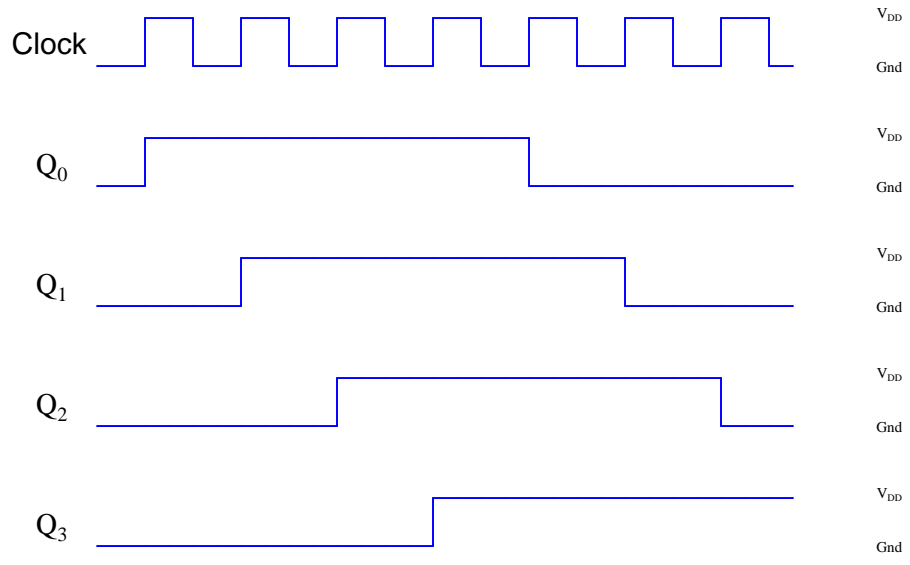
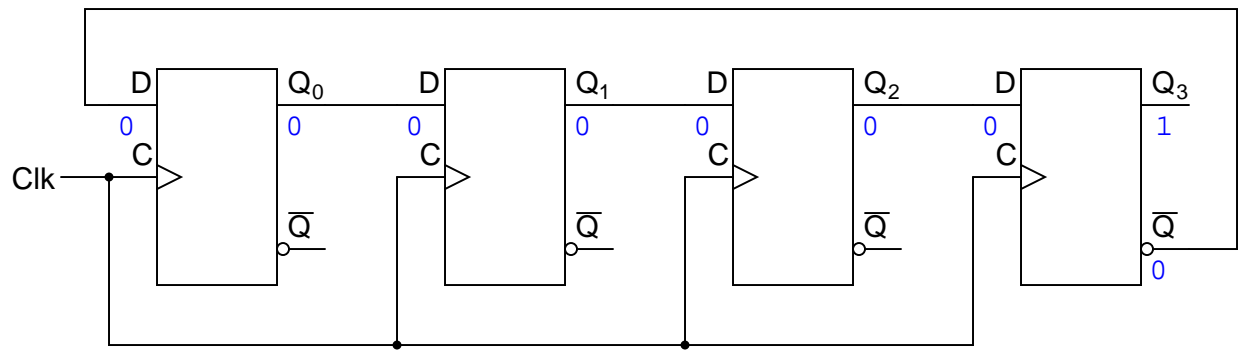

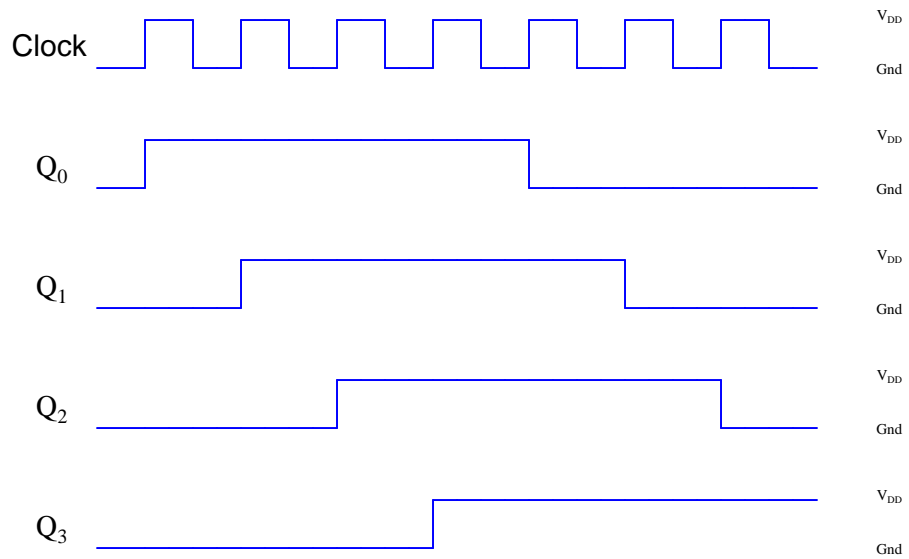
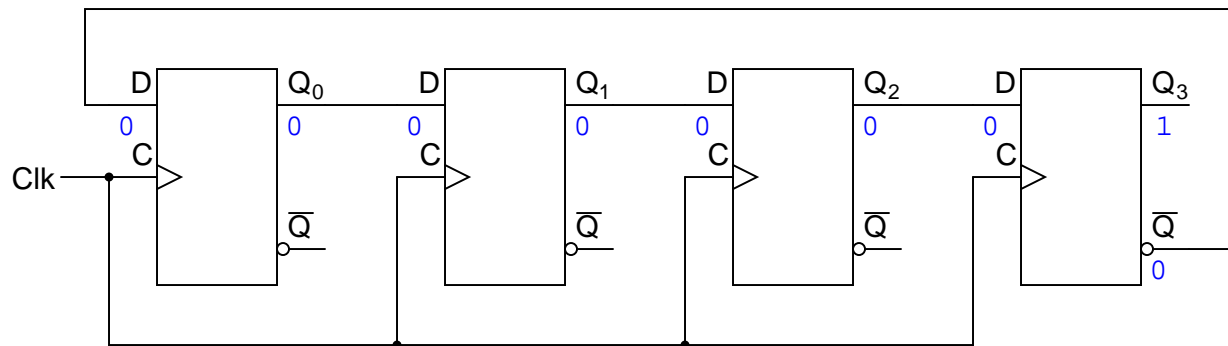

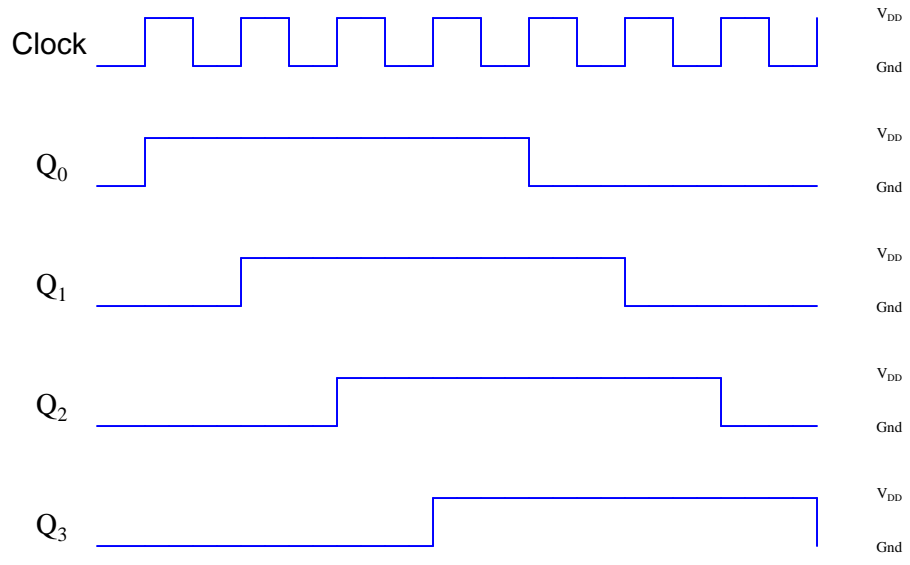
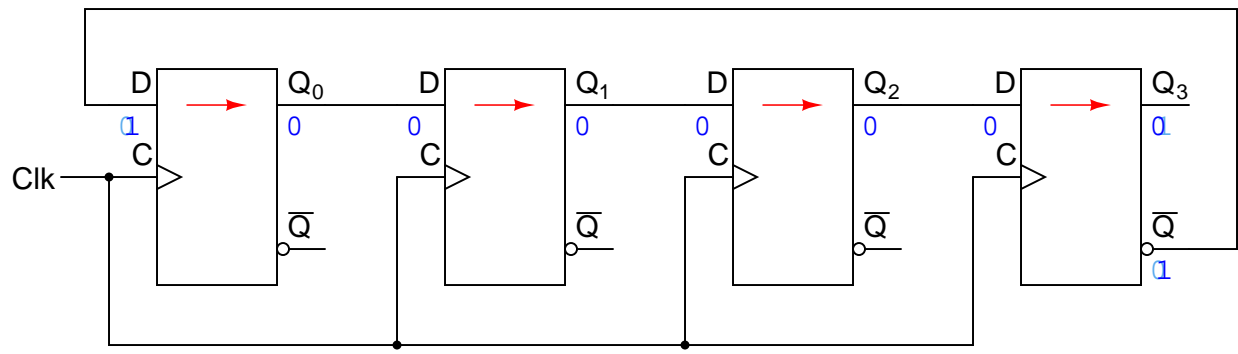

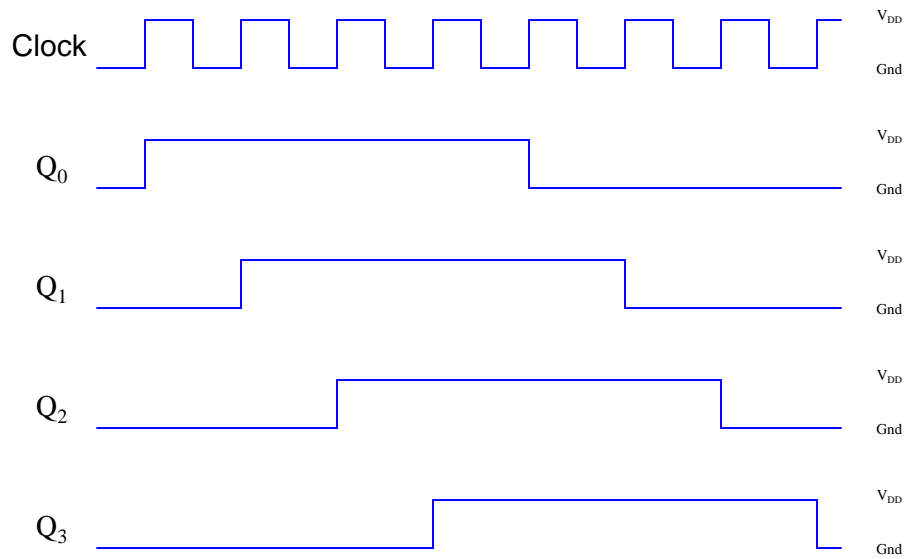
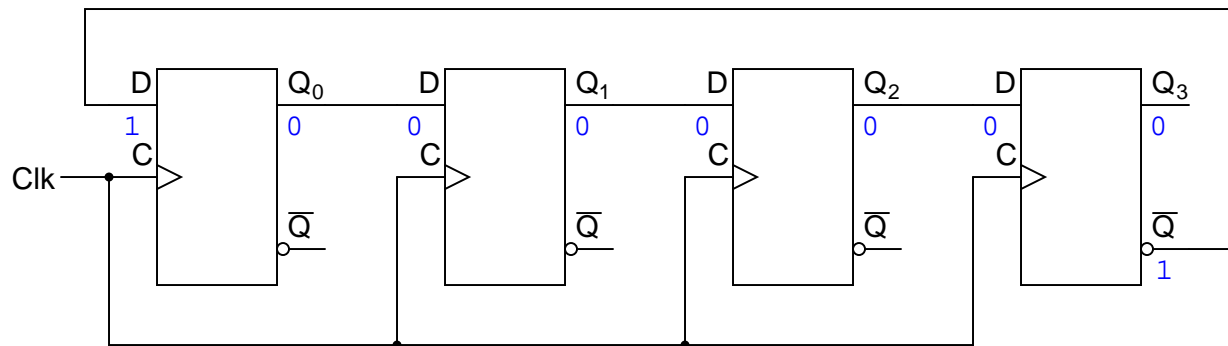

file 03234

Answer 1

Note that each rising edge of the clock pulse has its own frame in the animation sequence, to better show you what happens at those crucial times.

Notes 1

The purpose of this animation is to let students study the behavior of this counter circuit and reach their own conclusions. Similar to experimentation in the lab, except that here all the data collection is done visually rather than through the use of test equipment, and the students are able to "see" things that are invisible in real life.

In this animation, I show each rising edge of the clock signal in its own frame, whereas the falling edge of the clock shares a frame with the first half of the "low" state. I do this because these are positive edge-triggered flip-flops, and so the rising edge of the clock pulse is most important. I could have slowed things down on the falling edge of the clock as well, but since there is little "action" happening then, I decided to save a frame and make it a shorter animation.