

Question 1

Animation: simple circuit with switch

This question consists of a series of images (one per page) that form an animation. Flip the pages with your fingers to view this animation (or click on the "next" button on your viewer) frame-by-frame.

The following animation shows a simple circuit with one battery, two switches, and a resistor. Watch what happens when both switches are closed, and when either switch opens. Here are some things to look for:

- How do we define what an "open" switch is?
- What is opposite of "open" for an electric switch? Hint: it isn't "shut"
- Where does a voltage "drop" appear?
- Which direction do the electrons move?
- Compare the effects of the two switches: does one switch have any more effect on the circuit's current than the other? If so, which one?

Direction of electron motion

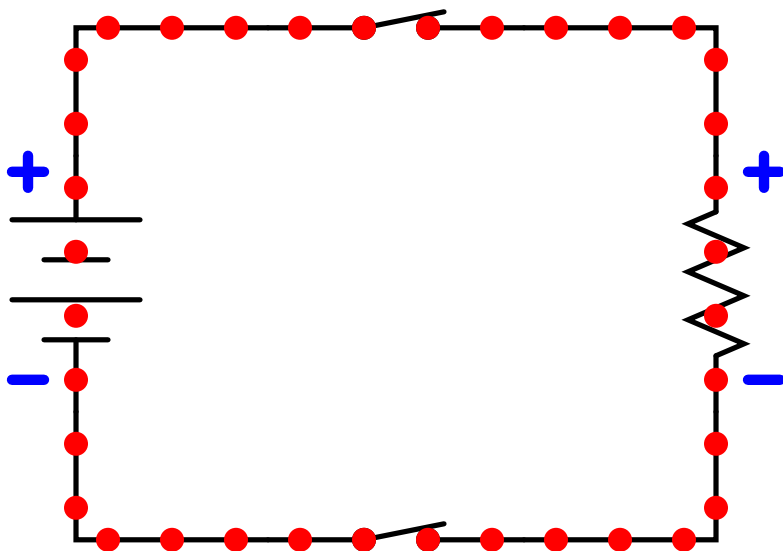

Direction of electron motion

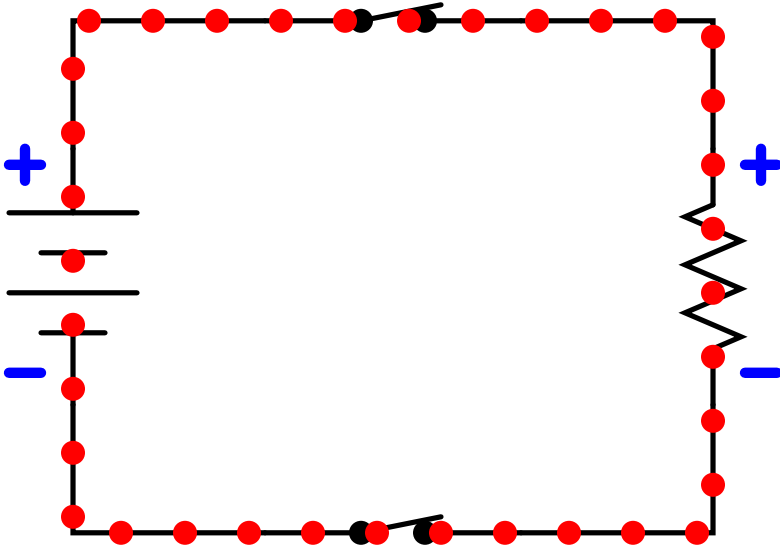

Direction of electron motion

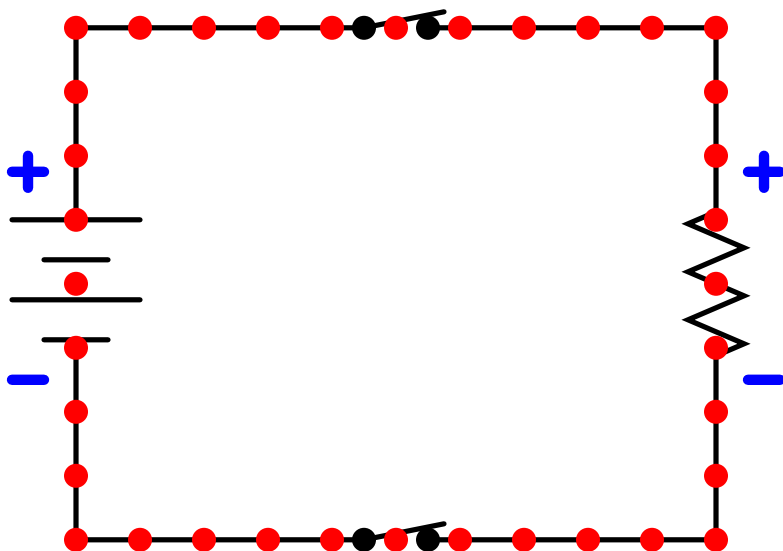

Direction of electron motion

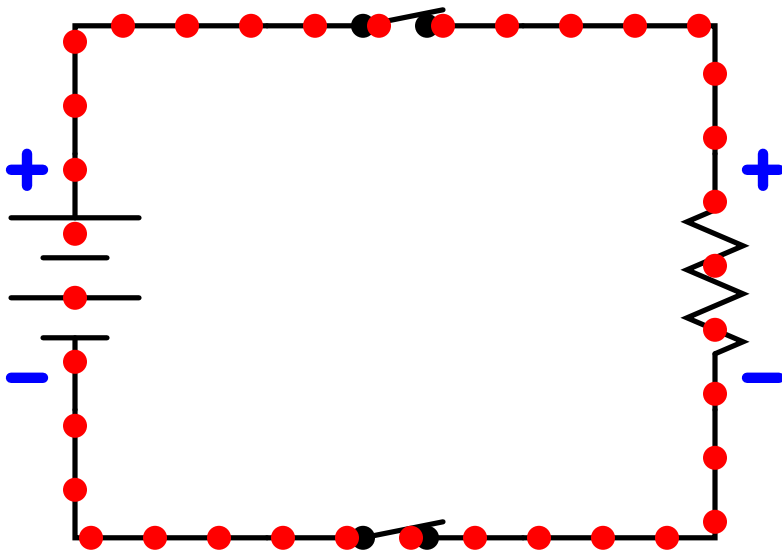

Direction of electron motion

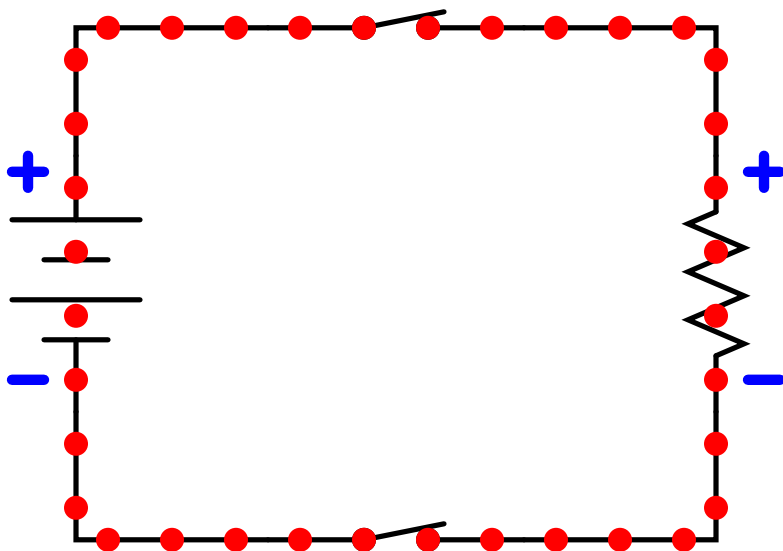

Direction of electron motion

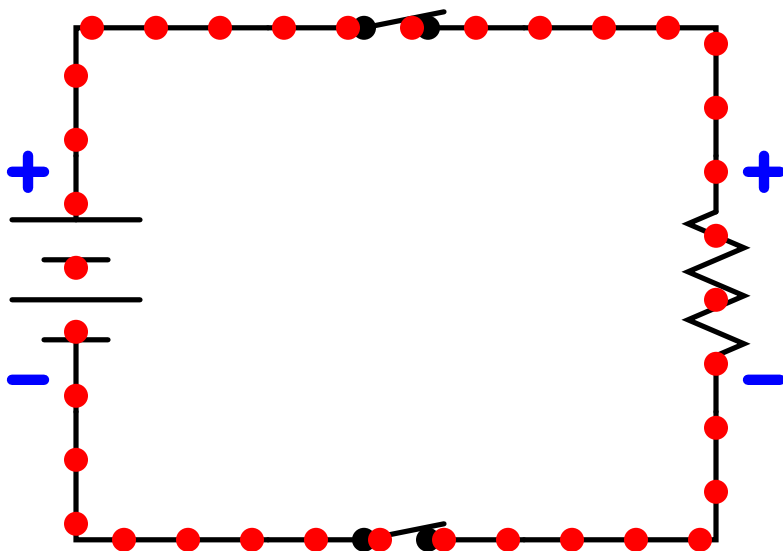

Direction of electron motion

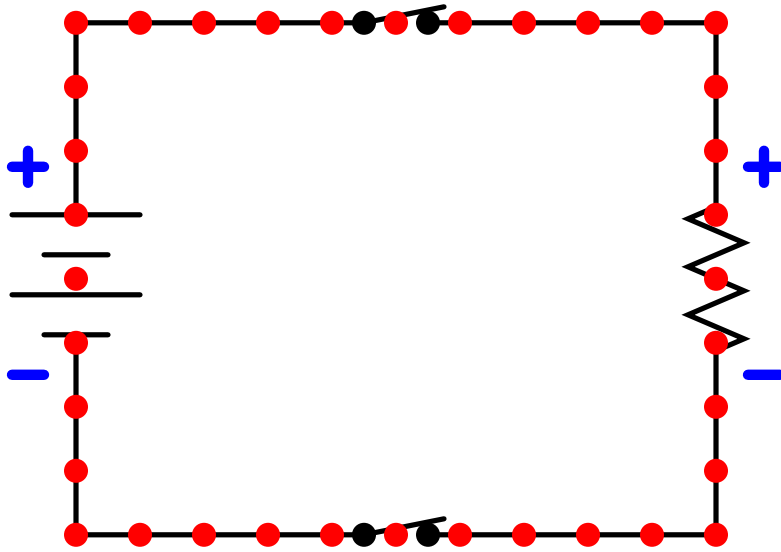

Direction of electron motion

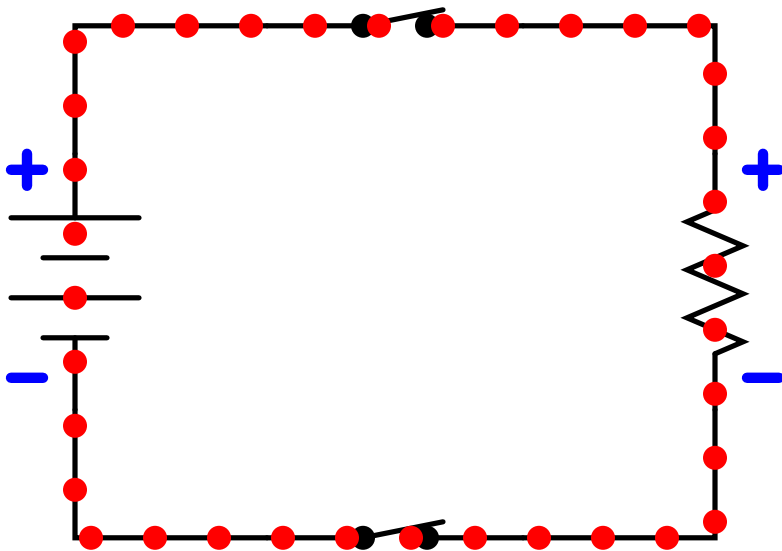

Direction of electron motion

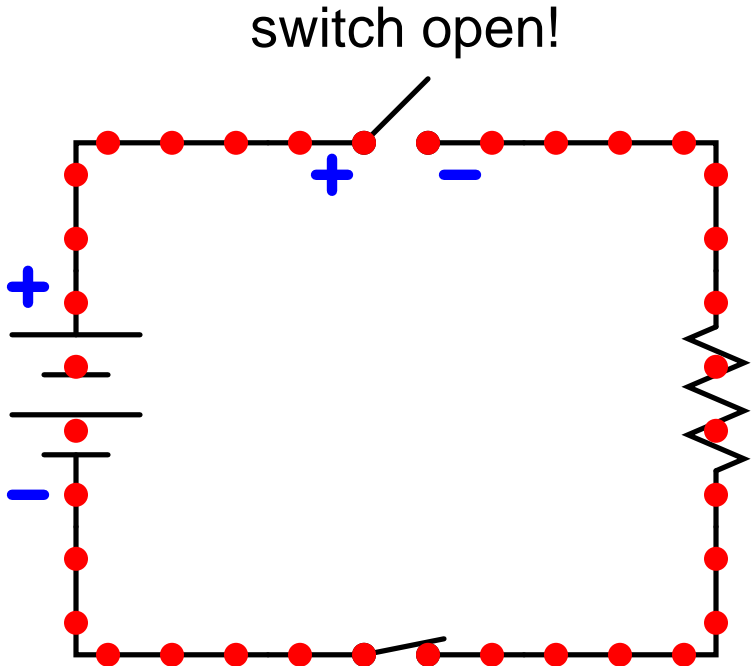

Direction of electron motion

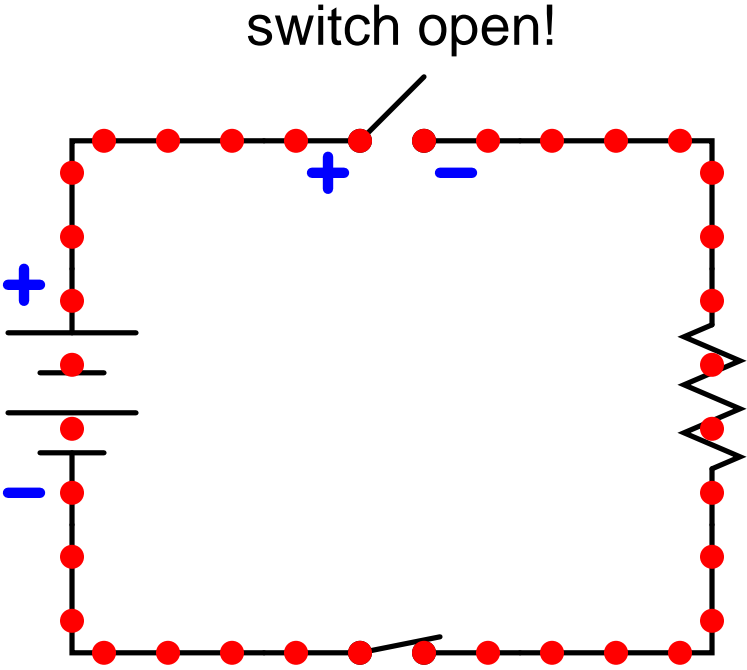

Direction of electron motion

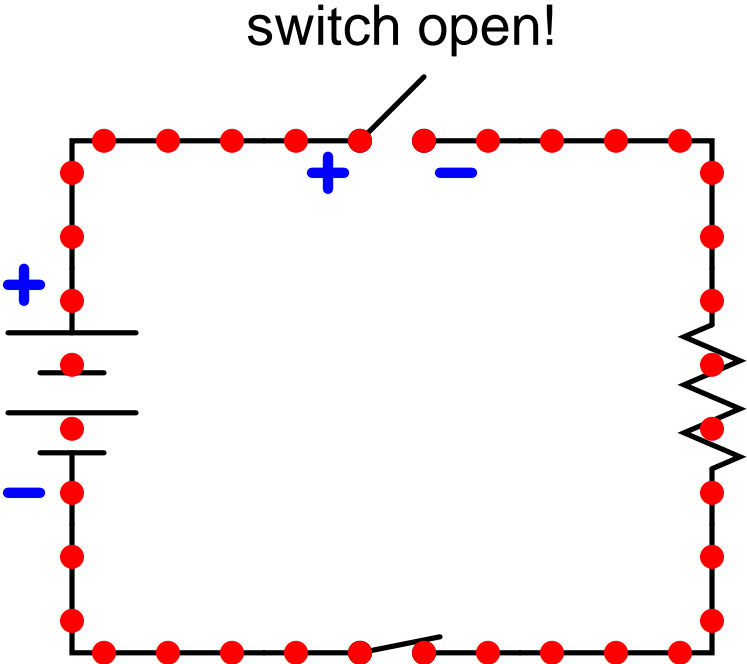

Direction of electron motion

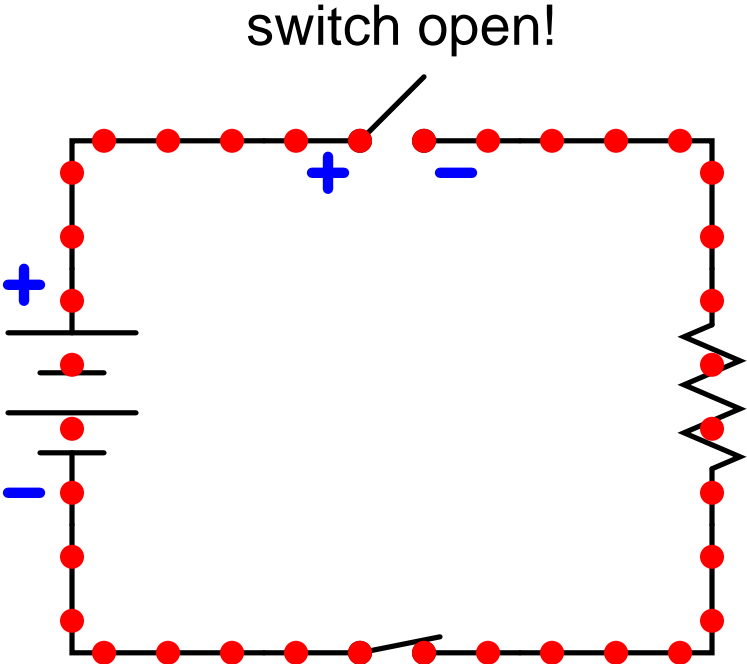

Direction of electron motion

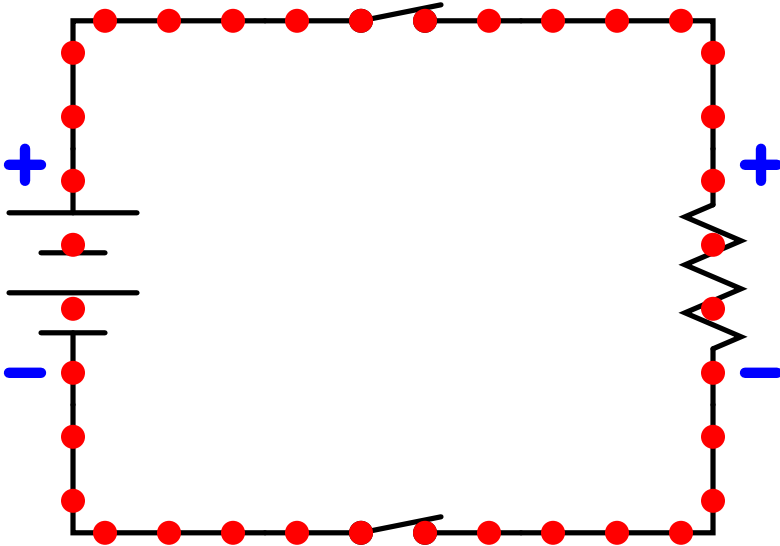

Direction of electron motion

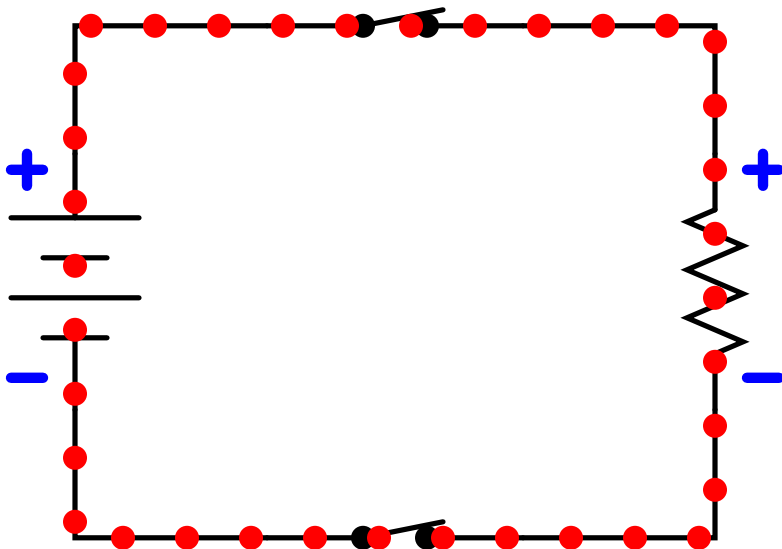

Direction of electron motion

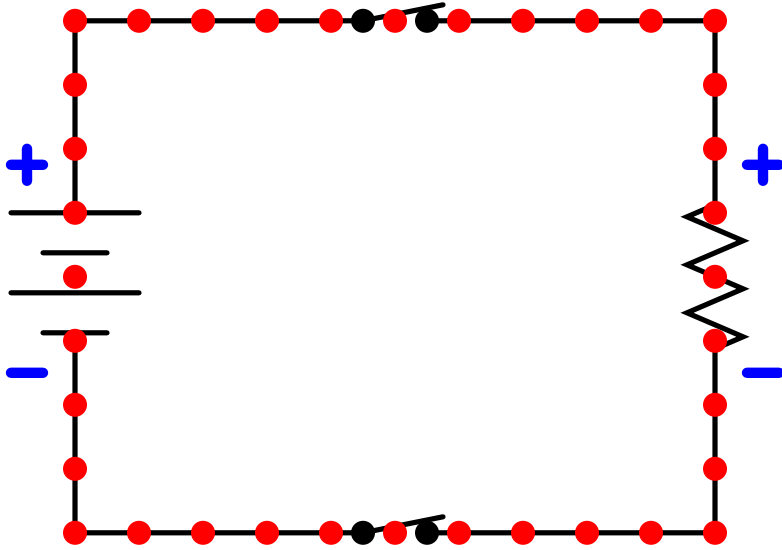

Direction of electron motion

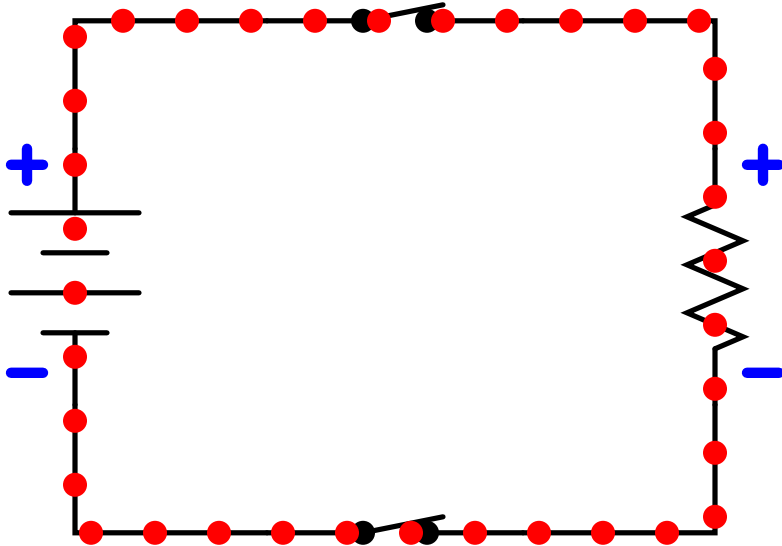

Direction of electron motion

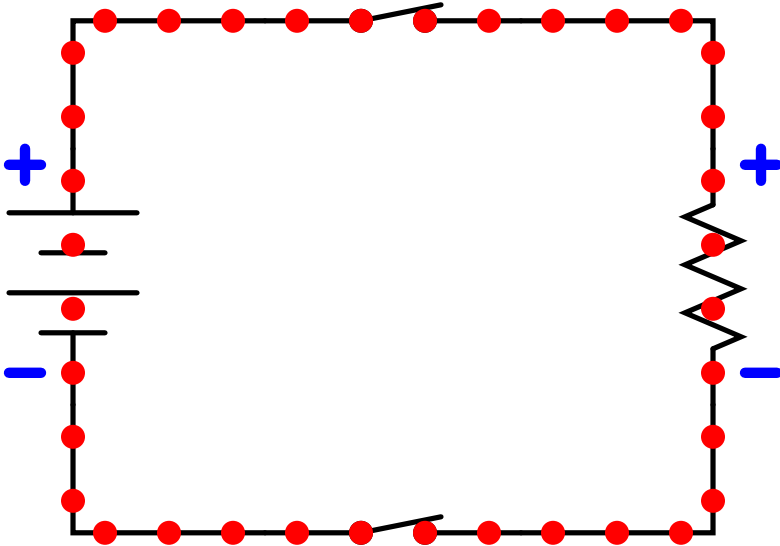

Direction of electron motion

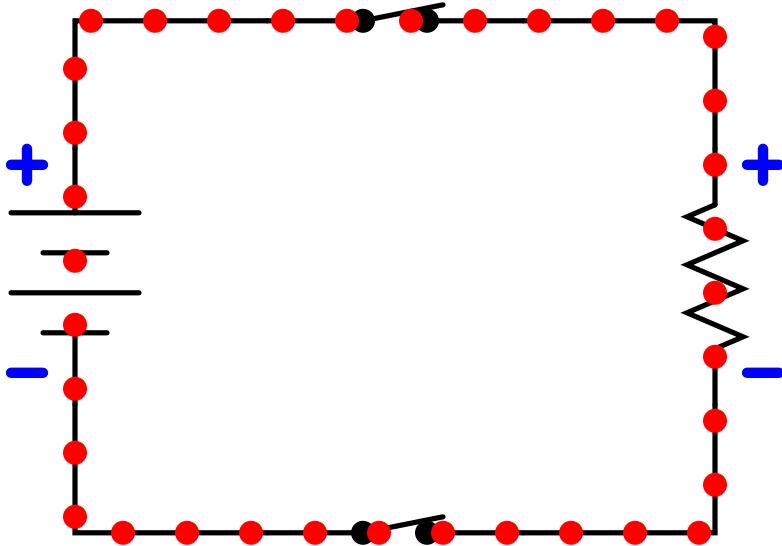

Direction of electron motion

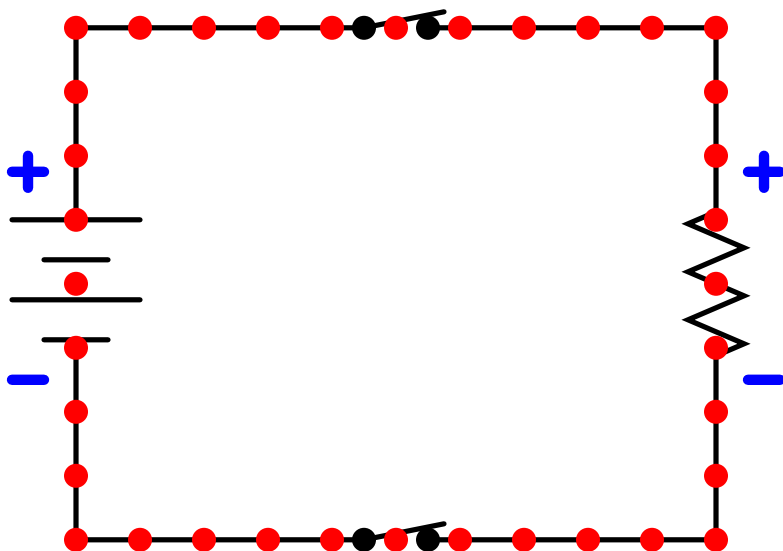

Direction of electron motion

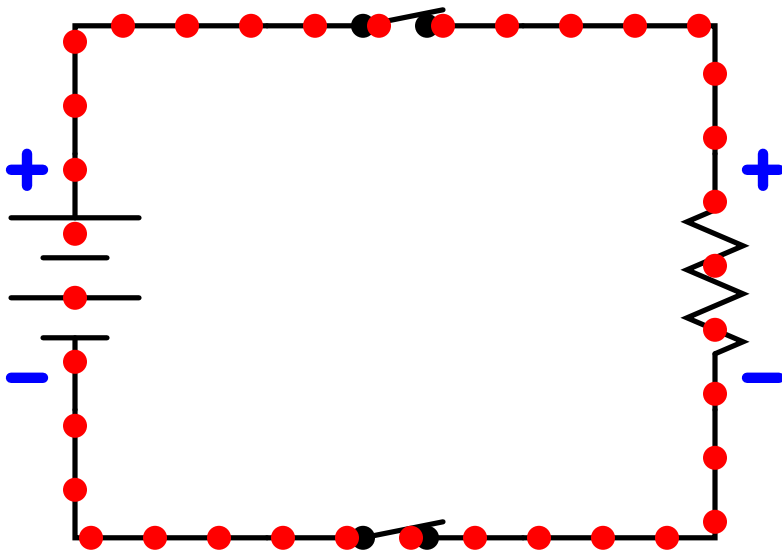

Direction of electron motion

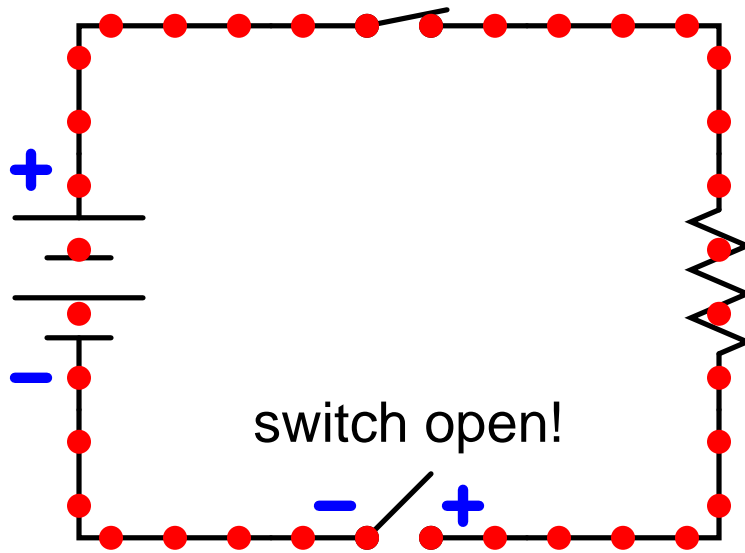

Direction of electron motion

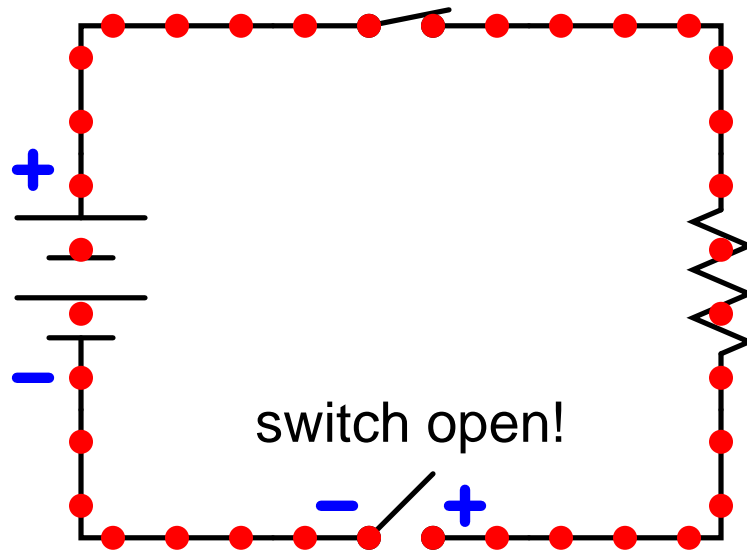

Direction of electron motion

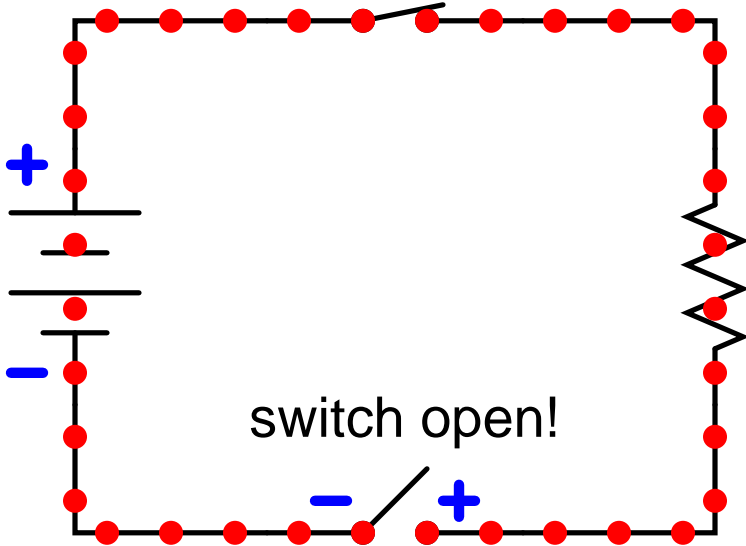

Direction of electron motion

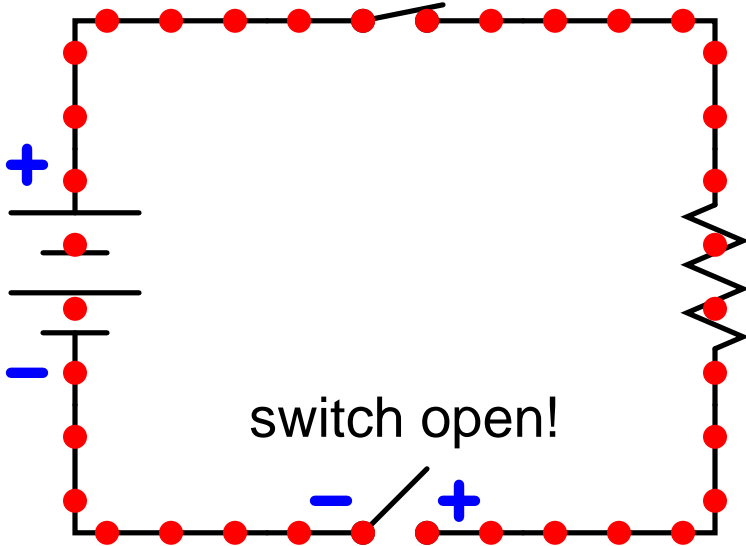

file 03231

Answer 1

Note how the opening of either switch is sufficient to halt current throughout the entire circuit. Note also how a voltage drop appears across the greatest circuit resistance (and the battery terminals, of course).

Notes 1

The purpose of this animation is to let students study the behavior of this switch circuit and reach their own conclusions. Similar to experimentation in the lab, except that here all the data collection is done visually rather than through the use of test equipment, and the students are able to "see" things that are invisible in real life.