

8-Pin, Stereo A/D Converter for Digital Audio

Features

- Single +5 V Power Supply
- 18-Bit Resolution
- 94 dB Dynamic Range
- Linear Phase Digital Anti-Alias Filtering
0.05dB Passband Ripple
80dB Stopband Rejection
- Low Power Dissipation: 150 mW
Power-Down Mode for Portable Applications
- Complete CMOS Stereo A/D System
Delta-Sigma A/D Converters
Digital Anti-Alias Filtering
S/H Circuitry and Voltage Reference
- Adjustable System Sampling Rates
including 32kHz, 44.1 kHz & 48kHz

General Description

The CS5330A / 31A is a complete stereo analog-to-digital converter which performs anti-alias filtering, sampling and analog-to-digital conversion generating 18-bit values for both left and right inputs in serial form. The output sample rate can be infinitely adjusted between 2 and 50 kHz.

The CS5330A / 31A operates from a single +5V supply and requires only 150 mW for normal operation, making it ideal for battery-powered applications.

The ADC uses delta-sigma modulation with 128X over-sampling, followed by digital filtering and decimation, which removes the need for an external anti-alias filter. The linear-phase digital filter has a passband to 21.7 kHz, 0.05 dB passband ripple and >80 dB stopband rejection. The device also contains a high pass filter to remove DC offsets.

The device is available in a 0.208" wide, 8-pin surface mount package.

ORDERING INFORMATION:

Model	Temp. Range	Package Type
CS5330A-KS	-10° to 70°C	8-pin plastic SOIC
CS5331A-KS	-10° to 70°C	8-pin plastic SOIC
CS5330A-BS	-40° to +85°C	8-pin plastic SOIC
CS5331A-BS	-40° to +85°C	8-pin plastic SOIC

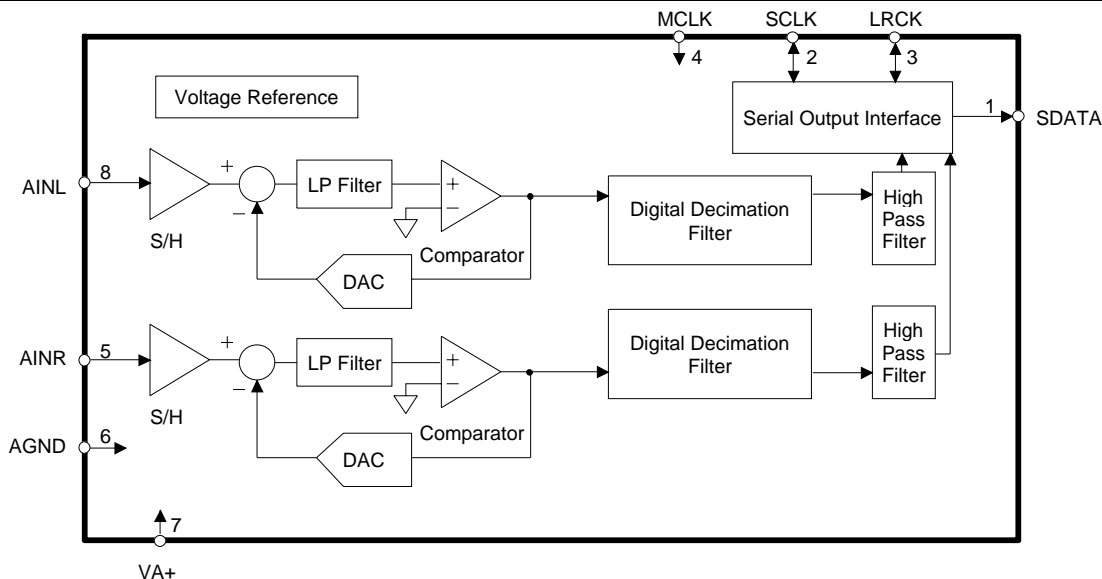

ANALOG CHARACTERISTICS ($T_A = 25^\circ\text{C}$; $V_{A+} = 5\text{V}$; -1 dBFS Input Sinewave, 997 Hz; $F_s = 48\text{ kHz}$; $MCLK = 12.288\text{ MHz}$; $SCLK = 3.072\text{ MHz}$; Measurement Bandwidth is 10 Hz to 20 kHz unless otherwise specified; Logic 0 = 0V, Logic 1 = V_{D+})

Parameter	Symbol	5330A/31A-KS			5330A/31A-BS			Units	
		Min	Typ	Max	Min	Typ	Max		
Temperature Range	T_A	-10 to +70			-40 to +85			$^\circ\text{C}$	
Dynamic Performance									
Dynamic Range	A-weighted	88	94	-	86	94	-	dB	
		86	92	-	84	92	-		
Total Harmonic Distortion+Noise	(Note 1)	THD+N	-	-84	75	-	-84	75	dB
	-1dB		-	-72	66	-	-72	66	
	-20dB		-	-32	26	-	-32	26	
	-60dB		-	-32	26	-	-32	26	
Total Harmonic Distortion	-1dB	THD	-	0.003	0.02	-	0.003	0.02	%
Interchannel Phase Deviation			-	0	-	-	0	-	Degree
Interchannel Isolation	(dc to 20 kHz)		-	90	-	-	90	-	dB
dc Accuracy									
Interchannel Gain Mismatch			-	0.1	-	-	0.1	-	dB
Gain Error			-	-	± 10	-	-	± 10	%
Gain Drift			-	150	-	-	150	-	ppm/ $^\circ\text{C}$
Offset Error	(Note 2)		-	-	0	-	-	0	LSB
Analog Input									
Full Scale Input Voltage Range		V_{IN}	3.6	4.0	4.4	3.6	4.0	4.4	V _{pp}
Input Impedance	($F_s = 48\text{ kHz}$)	Z_{IN}	-	100	-	-	100	-	k Ω
Input Bias Voltage			-	2.4	-	-	2.4	-	V
Power Supplies									
Power Supply Current	(Note 3)	I_{A+}	-	30	42	-	30	42	mA
	V_{A+} Power down		-	100	1000	-	100	1000	
Power Dissipation	(Note 3)		-	150	220	-	150	220	mW
	Normal Power Down		-	0.5	5.25	-	0.5	5.25	
Power Supply Rejection Ratio		PSRR	-	50	-	-	50	-	dB

* Refer to Parameter Definitions at the end of this data sheet.

- Notes: 1. Referenced to typical full-scale input voltage (4.0 V_{pp})
 2. Internal highpass filter removes offset.
 3. For max power calculations, $V_D = 5.25\text{ V}$.

DIGITAL CHARACTERISTICS

($T_A = 25\text{ }^\circ\text{C}$; $V_{A+} = 5V \pm 5\%$)

Parameter	Symbol	Min	Typ	Max	Units
High-Level Input Voltage	V_{IH}	2.4	-	-	V
Low-Level Input Voltage	V_{IL}	-	-	0.8	V
High-Level Output Voltage at $I_o = -20\text{ }\mu\text{A}$	V_{OH}	(V_{D+})-1.0	-	-	V
Low-Level Output Voltage at $I_o = 20\text{ }\mu\text{A}$	V_{OL}	-	-	0.4	V
Input Leakage Current	I_{in}	-	-	± 10.0	μA

DIGITAL FILTER CHARACTERISTICS

($T_A = 25\text{ }^\circ\text{C}$; $V_{A+} = 5V \pm 5\%$; $F_s = 48\text{ kHz}$)

Parameter	Symbol	Min	Typ	Max	Units
Passband (0.05 dB) (Note 4)		0.02	-	21.7	kHz
Passband Ripple		-	-	± 0.05	dB
Stopband (Note 4)		29	-	6115	kHz
Stopband Attenuation (Note 5)		80	-	-	dB
Group Delay (Note 6)	t_{gd}	-	15/ F_s	-	s
Group Delay Variation vs. Frequency	Δt_{gd}	-	-	0	μs
High Pass Filter Characteristics					
Frequency Response: -3 dB (Note 4)		-	3.7	-	Hz
-0.1 dB		-	20	-	Hz
Phase Deviation @ 20 Hz (Note 4)		-	10	-	Degree
Passband Ripple		-	-	0	dB

- Notes:
- Filter characteristics scale with output sample rate.
 - The analog modulator samples the input at 6.144 MHz for an output sample rate of 48 kHz. There is no rejection of input signals which are multiples of the sampling frequency ($n \times 6.144\text{ MHz} \pm 21.7\text{ kHz}$ where $n = 0, 1, 2, 3, \dots$).
 - Group delay for $F_s = 48\text{ kHz}$, $t_{gd} = 15/48\text{ kHz} = 312\text{ }\mu\text{s}$

ABSOLUTE MAXIMUM RATINGS (AGND = 0V, all voltages with respect to ground.)

Parameter	Symbol	Min	Typ	Max	Units
DC Power Supply:	VA+	-0.3	-	+6.0	V
Input Current, Any Pin Except Supplies (Note 7)	I _{in}	-	-	±10	mA
Analog Input Voltage (Note 8)	V _{INA}	-0.7	-	(VA+)+0.7	V
Digital Input Voltage (Note 8)	V _{IND}	-0.7	-	(VA+)+0.7	V
Ambient Temperature (power applied)	T _A	-55	-	+125	°C
Storage Temperature	T _{stg}	-65	-	+150	°C

Notes: 7. Any Pin except supplies. Transient currents of up to +/- 100 mA on the analog input pins will not cause SCR latch-up.

8. The maximum over/under voltage is limited by the input current.

WARNING: Operation at or beyond these limits may result in permanent damage to the device. Normal operation is not guaranteed at these extremes.

RECOMMENDED OPERATING CONDITIONS

(AGND = 0V; all voltages with respect to ground)

Parameter	Symbol	Min	Typ	Max	Units
DC Power Supplies:	VA+	4.75	5.0	5.25	V
Analog Input Voltage (Note 9)	V _{IN}	-	4	-	V _{pp}
Analog Input Bias Voltage		2.2	2.4	2.6	V

Note: 9. The output codes will clip at full scale with input signals > Full Scale and < VA+.

Specifications are subject to change without notice.

SWITCHING CHARACTERISTICS ($T_A = 25\text{ }^\circ\text{C}$; $V_{A+} = 5V \pm 5\%$; Inputs: Logic 0 = 0V, Logic 1 = V_{A+} ; $C_L = 20\text{ pF}$) Switching characteristics are guaranteed by characterization.

Parameter	Symbol	Min	Typ	Max	Units
Output Sample Rate	F_s	2	-	50	kHz
MCLK Period	MCLK / LRCK = 256 t_{clkw}	78		1000	ns
MCLK Low	MCLK / LRCK = 256 t_{ckl}	31	-	1000	ns
MCLK High	MCLK / LRCK = 256 t_{ckh}	31	-	1000	ns
MCLK Period	MCLK / LRCK = 384 t_{clkw}	52		1000	ns
MCLK Low	MCLK / LRCK = 384 t_{ckl}	20	-	1000	ns
MCLK High	MCLK / LRCK = 384 t_{ckh}	20	-	1000	ns
MCLK Period	MCLK / LRCK = 512 t_{clkw}	39		1000	ns
MCLK Low	MCLK / LRCK = 512 t_{ckl}	13	-	1000	ns
MCLK High	MCLK / LRCK = 512 t_{ckh}	13	-	1000	ns
MASTER MODE					
SCLK falling to LRCK	t_{mslr}	-10	-	10	ns
SCLK falling to SDATA valid	t_{sdo}	-10	-	35	ns
SCLK Duty cycle		-	50	-	%
SLAVE MODE					
LRCK duty cycle		25	50	75	%
SCLK Period	t_{sclkw}	(Note 10)	-	-	ns
SCLK Pulse Width Low	t_{sckl}	(Note 11)	-	-	ns
SCLK Pulse Width High	t_{sckh}	20	-	-	ns
SCLK falling to SDATA valid	t_{dss}	-	-	(Note 12)	ns
LRCK edge to MSB valid	t_{lrdss}	-	-	(Note 12)	ns
SCLK rising to LRCK edge delay	t_{slr1}	20	-	-	ns
LRCK edge to rising SCLK setup time	t_{slr2}	(Note 12)	-	-	ns

 Notes: 10. $\frac{1}{64 F_s}$

 11. $\frac{1}{128 F_s} - 15\text{ ns}$

 12. $\frac{1}{256 F_s} + 5\text{ ns}$

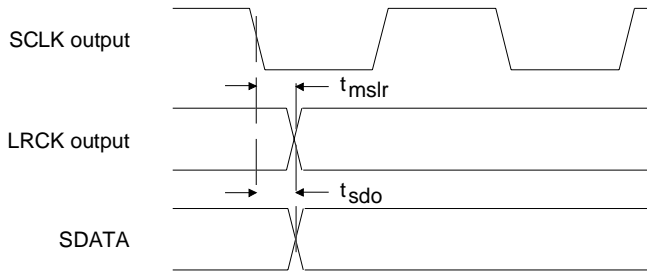

SCLK to SDATA LRCK - MASTER mode (CS5330A)

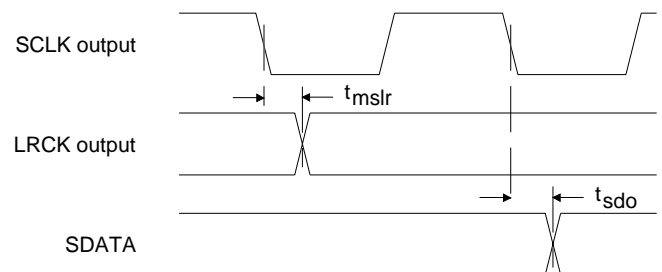

SCLK to SDATA LRCK - MASTER mode (CS5331A)

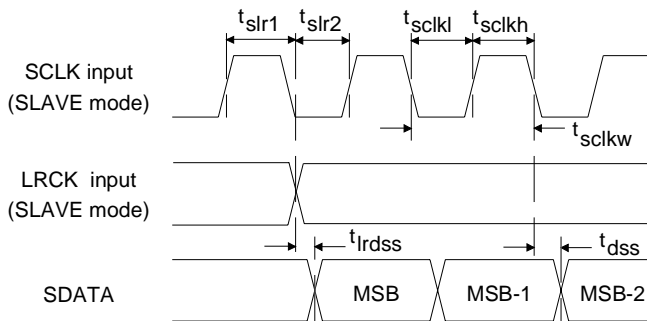

SCLK to LRCK & SDATA - SLAVE mode (CS5330A)

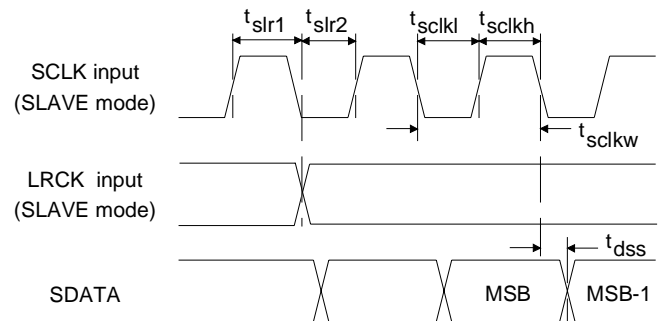

SCLK to LRCK & SDATA - SLAVE mode (CS5331A)

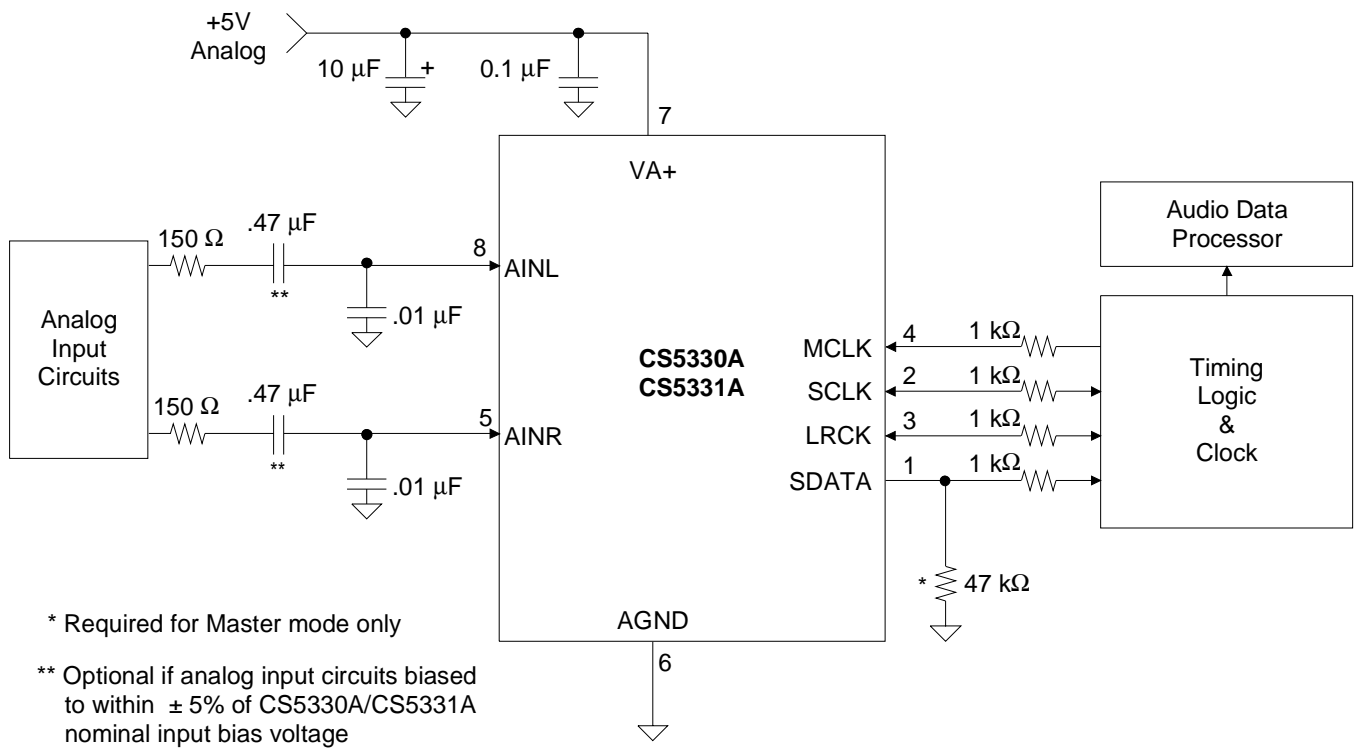

Figure 1. Typical Connection Diagram

GENERAL DESCRIPTION

The CS5330A and CS5331A are 18-bit, 2-channel Analog-to-Digital Converters designed for digital audio applications. Each device uses two one-bit delta-sigma modulators which simultaneously sample the analog input signals at 128 times the output sample rate (F_s). The resulting serial bit streams are digitally filtered, yielding pairs of 18-bit values. This technique yields nearly ideal conversion performance independent of input frequency and amplitude. The converters do not require difficult-to-design or expensive anti-alias filters and do not require external sample-and-hold amplifiers or a voltage reference.

The CS5330A and CS5331A differ only in the output serial data format. These formats are discussed in the following sections and shown in Figures 2 and 3.

An on-chip voltage reference provides for a single-ended input signal range of 4.0 Vpp. Output data is available in serial form, coded as 2's complement 18-bit numbers. Typical power consumption is 150 mW which can be further reduced to 0.5 mW using the Power-Down mode.

For more information on delta-sigma modulation, see the references at the end of this data sheet.

SYSTEM DESIGN

Very few external components are required to support the ADC. Normal power supply decoupling components and a resistor and capacitor on each input for anti-aliasing are all that's required, as shown in Figure 1.

Master Clock

The master clock (MCLK) runs the digital filter and is used to generate the delta-sigma modulator sampling clock. Table 1 shows some common

master clock frequencies. The output sample rate is equal to the frequency of the Left / Right Clock (LRCK). The serial nature of the output data results in the left and right data words being read at different times. However, the words within an LRCK cycle represent simultaneously sampled analog inputs. The serial clock (SCLK) shifts the digitized audio data from the internal data registers via the SDATA pin.

Serial Data Interface

LRCK (kHz)	MCLK (MHz)		
	256×	384×	512×
32	8.1920	12.2880	16.3840
44.1	11.2896	16.9344	22.5792
48	12.2880	18.4320	24.5760

Table 1. Common Clock Frequencies

The CS5330A and CS5331A can be operated in either Master mode, where SCLK and LRCK are outputs, or SLAVE mode, where SCLK and LRCK are inputs.

Master Mode

In Master mode, SCLK and LRCK are outputs which are internally derived from MCLK. The CS5330A/31A will divide MCLK by 4 to generate a SCLK which is $64 \times F_s$ and by 256 to generate LRCK. The CS5330A and CS5331A can be placed in the Master mode with a 47 kohm pull-down resistor on the SDATA pin as shown in Figure 1.

Slave Mode

LRCK and SCLK become inputs in SLAVE mode. LRCK must be externally derived from MCLK and be equal to F_s . The frequency of SCLK should be equal to $64 \times LRCK$, though other frequencies are possible.

MCLK frequencies of $256 \times$, $384 \times$, and $512 \times F_s$ are supported. The ratio of the applied MCLK to

LRCK is automatically detected during power-up and internal dividers are set to generate the appropriate internal clocks.

CS5330A

The CS5330A data output format is shown in Figure 2. Notice that the MSB is clocked by the transition of LRCK and the remaining seventeen data bits are clocked by the falling edge of SCLK. The data bits are valid during the rising edge of SCLK.

CS5331A

The CS5331A data output format is shown in Figure 3. Notice the one SCLK period delay between the LRCK transitions and the MSB of the data. The falling edges of SCLK cause the ADC to output the eighteen data bits. The data bits are valid during the rising edge of SCLK. LRCK is also inverted compared to the CS5330A interface. The CS5331A interface is compatible with I²S.

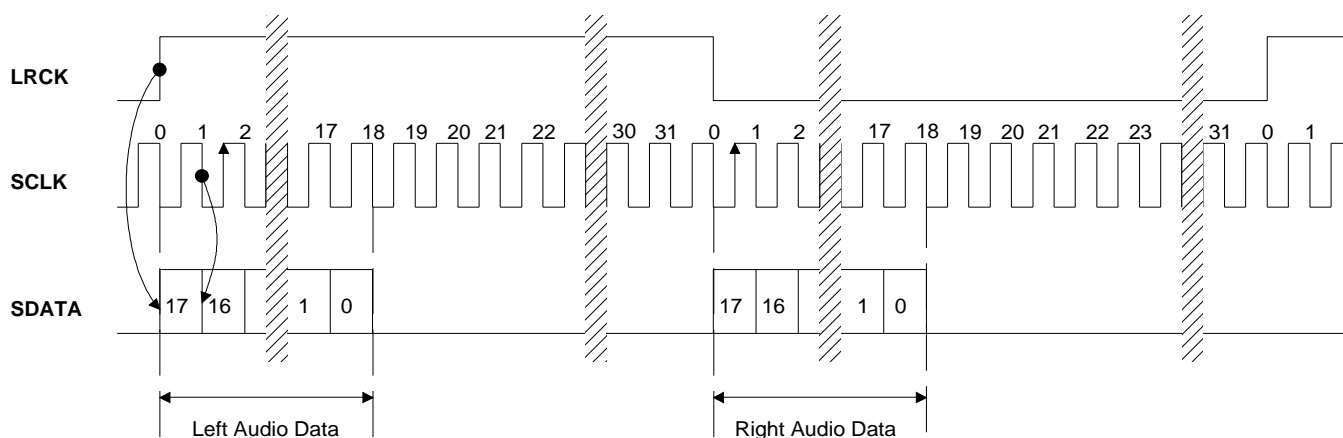

Figure 2. Data Output Timing - CS5330A

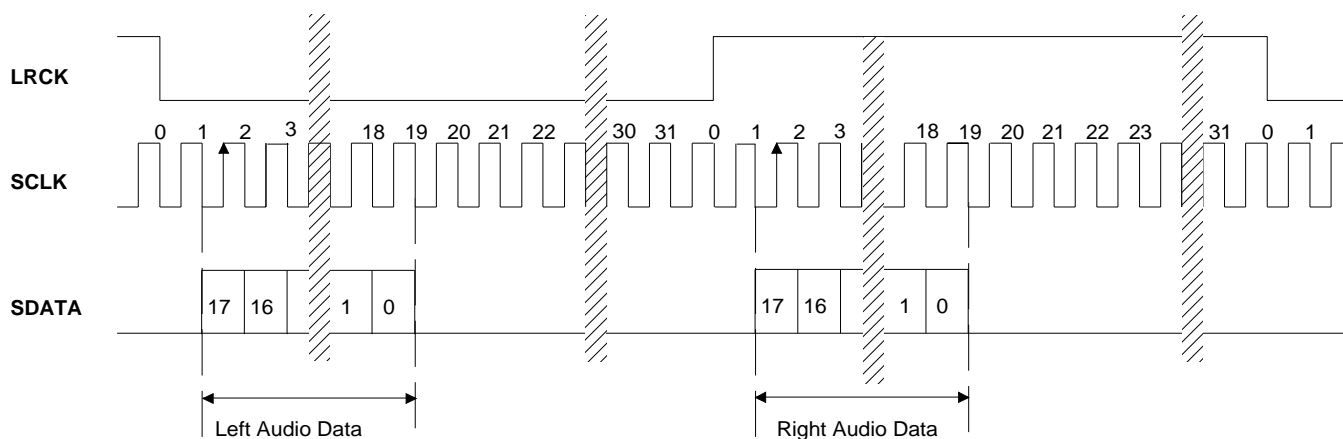

Figure 3. Data Output Timing - CS5331A (I²S compatible)

Analog Connections

Figure 1 shows the analog input connections. The analog inputs are presented to the modulators via the AINR and AINL pins. Each analog input will accept a maximum of 4 Vpp centered at +2.4 V.

The CS5330A/31A samples the analog inputs at $128 \times F_s$, 6.144 MHz for a 48 kHz sample-rate. The digital filter rejects all noise above 29 kHz except for frequencies right around 6.144 MHz \pm 21.7 kHz (and multiples of 6.144 MHz). Most audio signals do not have significant energy at 6.144 MHz. Nevertheless, a 150 Ω resistor in series with each analog input and a 10 nF capacitor across the inputs will attenuate any noise energy at 6.144 MHz, in addition to providing the optimum source impedance for the modulators. The use of capacitors which have a large voltage coefficient must be avoided since these will degrade signal linearity. It is also important that the self-resonant frequency of the capacitor be well above the modulator sampling frequency. General purpose ceramics and film capacitors do not meet these requirements. However, NPO and COG capacitors are acceptable. If active circuitry precedes the ADC, it is recommended that the above RC filter is placed between the active circuitry and the AINR and AINL pins. The above example frequencies scale linearly with F_s .

High Pass Filter

The operational amplifiers in the input circuitry driving the CS5330A/31A may generate a small DC offset into the A/D converter. The CS5330A/31A includes a high pass filter after the decimator to remove any DC offset which could result in recording a DC level, possibly yielding "clicks" when switching between devices in a multichannel system.

The characteristics of this first-order high pass filter are outlined below for F_s equal 48 kHz.

This filter response scales linearly with sample rate.

Frequency response:-3 dB @ 3.7 Hz

-0.1 dB @ 20 Hz

Phase deviation:10 degrees @ 20 Hz

Passband ripple:None

Initialization and Power-Down

The Initialization and Power-Down sequence is shown in Figure 4. Upon initial power-up, the digital filters and delta-sigma modulators are reset and the internal voltage reference is powered down. The device will remain in the Initial Power-Down mode until MCLK is presented. Once MCLK is available, the CS5330A/31A will make a master/slave mode decision based upon the presence/absence of a 47 kohm pull-down resistor on SDATA as shown in Figure 1. The master/slave decision is made during initial power-up as shown in Figure 4.

In master mode, SCLK and LRCK are outputs where the MCLK/LRCK frequency ratio is $256 \times$. LRCK will appear as an output 127 MCLK cycles into the initialization sequence. At this time, power is applied to the internal voltage reference and the analog inputs will move to approximately 2.4 Volts. SDATA is static low during the initialization and high pass filter settling sequence, which requires 11,265 LRCK cycles (235 ms at a 48 kHz output sample rate).

In slave mode, SCLK and LRCK are inputs where the MCLK/LRCK frequency ratio must be either $256 \times$, $384 \times$ or $512 \times$. Once the MCLK and LRCK are detected, MCLK occurrences are counted over one LRCK period to determine the MCLK/LRCK frequency ratio. At this time, power is applied to the internal voltage reference and the analog inputs will move to approximately 2.4 Volts. SDATA is static high during the initialization and high pass filter settling sequence, which requires 11,265 LRCK cycles (235 ms at a 48 kHz sample rate).

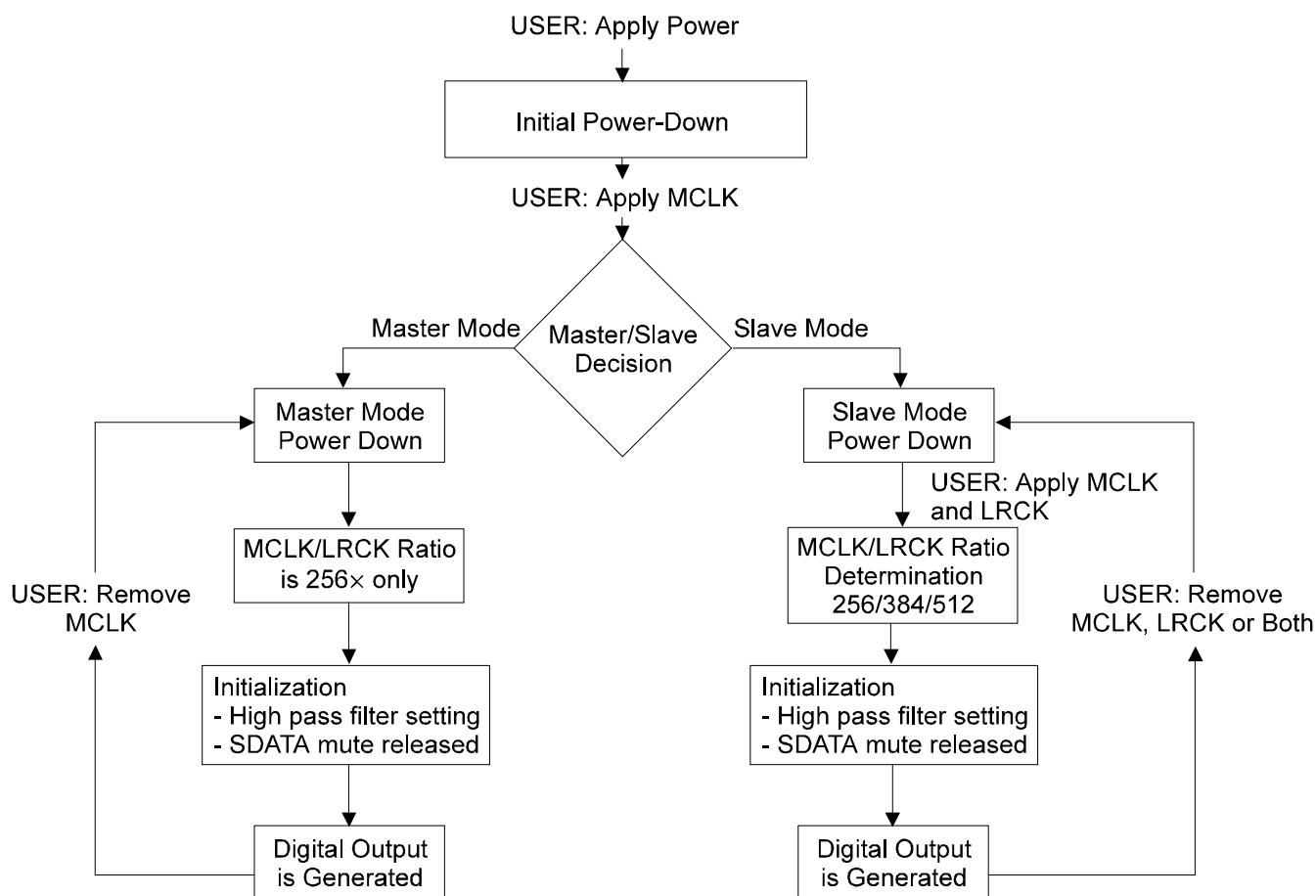

Figure 4. CS5330A/31A Initialization and Power-Down Sequence

The CS5330A and CS5331A have a Power-Down mode wherein typical consumption drops to 0.5 mW. This is initiated when a loss of clock is detected on either the LRCK or MCLK pins in Slave Mode, or the MCLK pin in Master Mode. The initialization sequence will begin when MCLK, and LRCK for slave mode, are restored. In slave mode power-down, the CS5330A and CS5331A will adapt to changes in MCLK/LRCK frequency ratio during the initialization sequence. It is recommended that clocks not be applied to the device prior to power supply settling. A reset circuit may be implemented by gating the MCLK signal.

Grounding and Power Supply Decoupling

As with any high resolution converter, the ADC requires careful attention to power supply and grounding arrangements if its potential performance is to be realized. Figure 1 shows the recommended power arrangements with VA+ connected to a clean +5V supply. Decoupling capacitors should be as near to the ADC as possible, with the low value ceramic capacitor being the nearest. To minimize digital noise, connect the ADC digital outputs only to CMOS inputs. The printed circuit board layout should have separate analog and digital regions and ground planes. An evaluation board, CDB5330A or CDB5331A, is available which demonstrates the optimum layout and power supply arrangements, as well as allowing fast evaluation of the CS5330A and CS5331A.

Digital Filter

Figures 5 through 8 show the attenuation characteristics of the digital filter included in the ADC. The filter response scales linearly with sample rate. The x-axis has been normalized to F_s , and can be scaled by multiplying the x-axis by the system sample rate, i.e. 48kHz.

Schematic & Layout Review Service

**Confirm Optimum
Schematic & Layout
Before Building Your Board.**

**For Our Free Review Service
Call Applications Engineering.**



C a l l : (5 1 2) 4 4 5 - 7 2 2 2

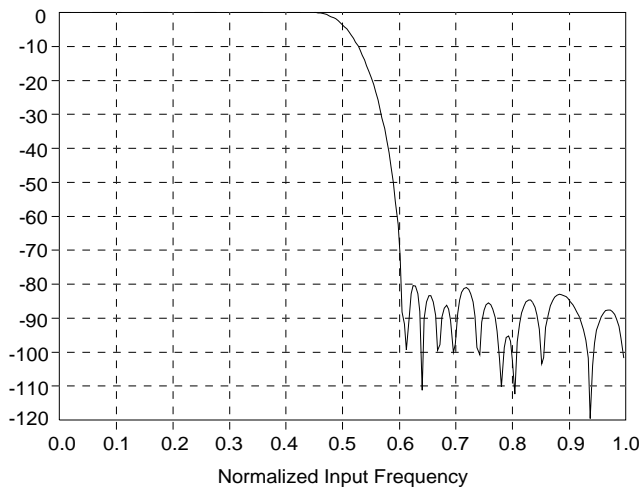

Figure 5. CS5330A/31A Digital Filter Stopband Rejection

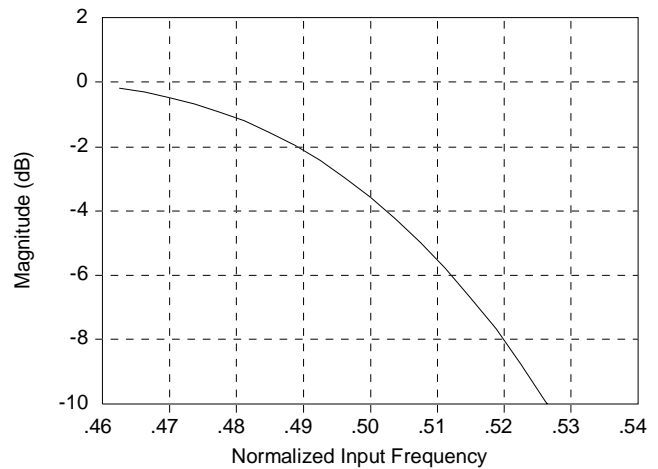

Figure 6. CS5330A/31A Digital Filter Transition Band

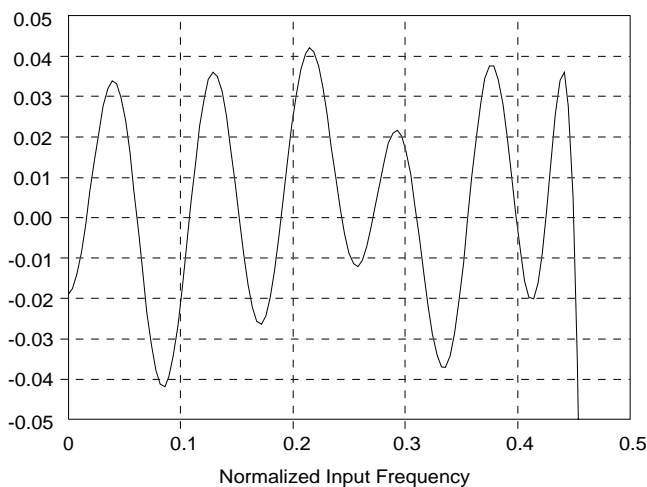

Figure 7. CS5330A/31A Digital Filter Passband Ripple

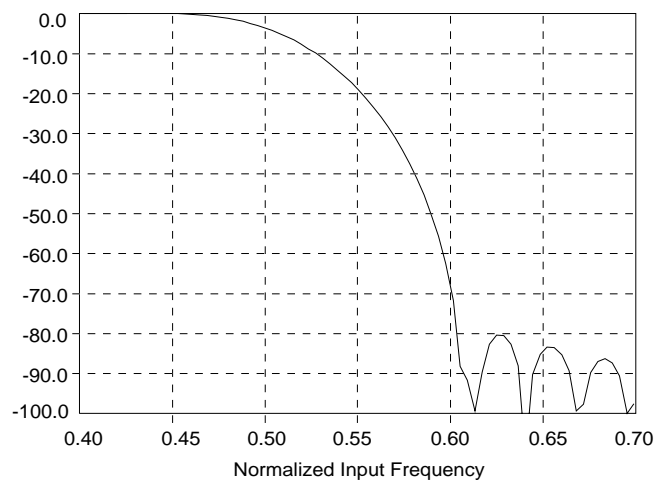









Figure 8. CS5330A/31A Digital Filter Transition Band

PIN DESCRIPTIONS

SERIAL DATA OUTPUT	SDATA			AINL	LEFT ANALOG INPUT
SERIAL DATA CLOCK	SCLK			VA+	ANALOG POWER
LEFT/RIGHT CLOCK	LRCK			AGND	ANALOG GROUND
MASTER CLOCK	MCLK			AINR	RIGHT ANALOG INPUT

Power Supply Connections

VA+ - Positive Analog Power, PIN 7.
Positive analog supply (Nominally +5V).

AGND - Analog Ground, PIN 6.
Analog ground reference.

Analog Inputs

AINL - Analog Left Channel Input, PIN 8.
Analog input for the left channel. Typically 4Vpp for a full-scale input signal.

AINR - Analog Right Channel Input, PIN 5.
Analog input for the right channel. Typically 4Vpp for a full-scale input signal.

Digital Inputs

MCLK - Master Clock Input, PIN 4.

Source for the delta-sigma modulator sampling and digital filter clock. Sample rates and digital filter characteristics scale to the MCLK frequency.

Digital Inputs or Outputs

SCLK - Serial Data Clock, PIN 2.

SCLK is an input clock at any frequency from 32× to 64× the output word rate. SCLK can also be an output clock at 64× if in the Master Mode. Data is clocked out on the falling edge of SCLK.

LRCK - Left/Right Clock, PIN 3.

LRCK selects the left or right channel for output on SDATA. The LRCK frequency must be at the output sample rate. LRCK is an output clock if in Master Mode. Although the outputs of each channel are transmitted at different times, the two words in an LRCK cycle represent simultaneously sampled analog inputs.

Digital Outputs

SDATA - Audio Serial Data Output, PIN 1.

Two's complement MSB-first serial data is output on this pin. A 47 kohm resistor on this pin will place the CS5330A/31A into Master Mode.

PARAMETER DEFINITIONS

Resolution - The total number of possible output codes is equal to 2^N , where N = the number of bits in the output word for each channel.

Dynamic Range - The ratio of the full scale rms value of the signal to the rms sum of all other spectral components over the specified bandwidth. Dynamic range is a signal-to-noise measurement over the specified bandwidth made with a -60 dBFS signal. 60 dB is then added to the resulting measurement to refer the measurement to full scale. This technique ensures that the distortion components are below the noise level and do not effect the measurement. This measurement technique has been accepted by the Audio Engineering Society, AES17-1991, and the Electronic Industries Association of Japan, EIAJ CP-307.

Total Harmonic Distortion+Noise (THD+N) - The ratio of the rms value of the signal to the rms sum of all other spectral components over the specified band width (typically 10 Hz to 20 kHz), including distortion components. Expressed in decibels. Measured at -1 and -20 dBFS as suggested in AES17-1991 Annex A.

Total Harmonic Distortion - The ratio of the rms sum of all harmonics up to 20 kHz to the rms value of the signal.

Interchannel Phase Deviation - The phase difference between the left and right channel sampling times.

Interchannel Isolation - A measure of crosstalk between the left and right channels. Measured for each channel at the converter's output with the input under test AC grounded and a full-scale signal applied to the other channel. Units in decibels.

Interchannel Gain Mismatch - The gain difference between left and right channels. Units in decibels.

Gain Error - The deviation of the measured full scale amplitude from the ideal full scale amplitude value.

Gain Drift - The change in gain value with temperature. Units in ppm/°C.

Bipolar Offset Error - The deviation of the mid-scale transition (111...111 to 000...000) from the ideal. Units in LSBs.

REFERENCES

- 1) " Area Efficient Decimation Filter for an 18-Bit Delta- Sigma ADC" by K. Lin and J.J. Paulos . Paper presented at the 98th Convention of the Audio Engineering Society, February 1995.
- 2) " An 18-Bit, 8-Pin Stereo Digital-to-Analog Converter" by J.J. Paulos, A.W. Krone, G.D. Kamath and S.T. Dupuie. Paper presented at the 97th Convention of the Audio Engineering Society, November 1994.
- 3) " An 18-Bit Dual-Channel Oversampling Delta-Sigma A/D Converter, with 19-Bit Mono Application Example" by Clif Sanchez. Paper presented at the 87th Convention of the Audio Engineering Society, October 1989.
- 4) " The Effects of Sampling Clock Jitter on Nyquist Sampling Analog-to-Digital Converters, and on Oversampling Delta Sigma ADC's" by Steven Harris. Paper presented at the 87th Convention of the Audio Engineering Society, October 1989.
- 5) "A Stereo 16-bit Delta-Sigma A/D Converter for Digital Audio" by D.R. Welland, B.P. Del Signore, E.J. Swanson, T. Tanaka, K. Hamashita, S. Hara, K. Takasuka. Paper presented at the 85th Convention of the Audio Engineering Society, November 1988.

PACKAGE DESCRIPTIONS

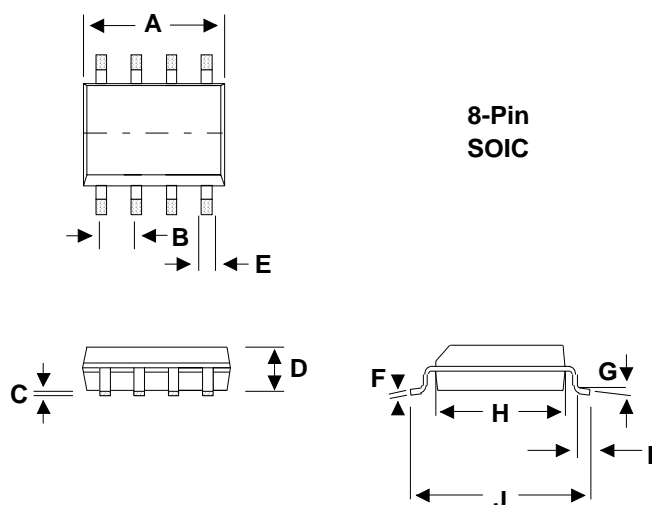

DIM	MILLIMETERS		INCHES	
	MIN	MAX	MIN	MAX
A	5.15	5.35	0.203	0.210
B	1.27	TYP	0.050	TYP
C	0	0.25	0	0.010
D	1.77	1.88	0.070	0.074
E	0.33	0.51	0.013	0.020
F	0.15	0.25	0.006	0.010
G	0°	8°	0°	8°
H	5.18	5.4	0.204	0.213
I	0.48	0.76	0.019	0.030
J	7.67	8.1	0.302	0.319

Note: The EIAJ Package is not a standard JEDEC package size.

• Notes •

Evaluation Board for CS5330A / CS5331A

Features

- Demonstrates recommended layout and grounding arrangements
- CS8402A Generates AES/EBU, S/PDIF, & EIAJ-340 Compatible Digital Audio
- Buffered Serial Output Interface
- Digital and Analog Patch Areas
- On-board or externally supplied system timing

General Description

The CDB5330A/31A evaluation board is an excellent means for quickly evaluating the CS5330A/31A 18-bit, stereo A/D converter. Evaluation requires a digital signal processor, a low distortion analog signal source and a power supply. Analog inputs are provided via RCA connectors for both channels.

Also included is a CS8402A digital audio interface transmitter which generates AES/EBU, S/PDIF, and EIAJ-340 compatible audio data. The digital audio data is available via RCA phono, and optical connectors.

The evaluation board may also be configured to accept external timing signals for operation in a user application during system development.

ORDERING INFORMATION: CDB5330A, CDB5331A

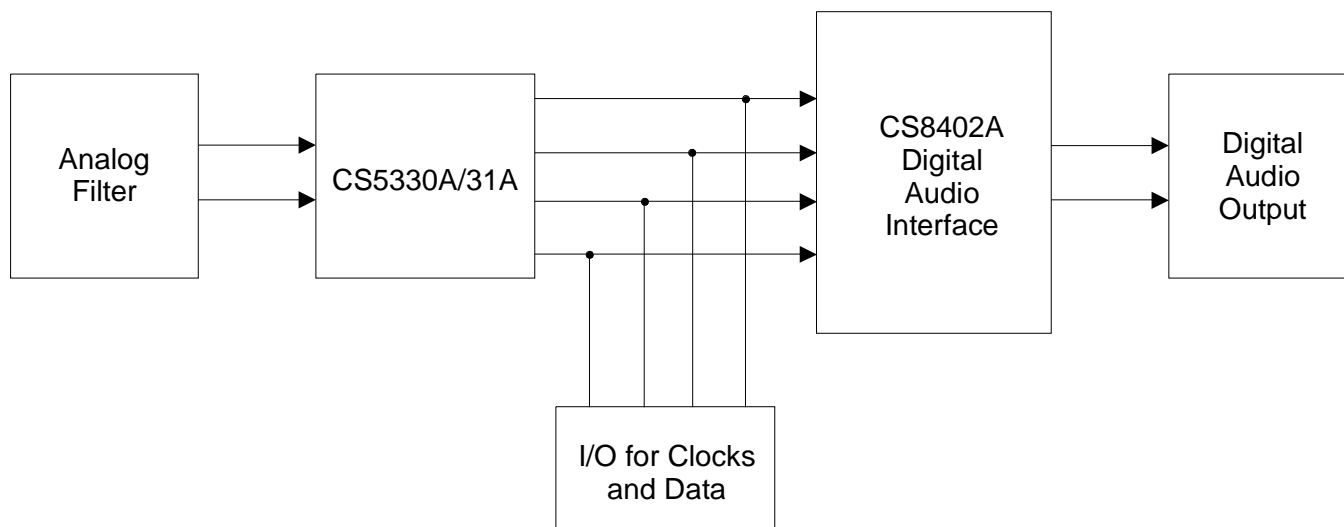

CDB5330A/31A System Overview

The CDB5330A/31A evaluation board is an excellent means of quickly evaluating the CS5330A/31A. The CS8402A digital audio interface transmitter provides an easy interface to digital audio signal processors, including the majority of digital audio test equipment. The evaluation board has been designed to accept an analog input, and provide a digital output that is either optical or coax. The evaluation board also allows the user to supply clocks and data through a 10-pin header for system development.

The CDB5330A/31A schematic has been partitioned into 5 schematics shown in Figures 2 through 6. Each partitioned schematic is represented in the system diagram shown in Figure 1. Notice that the the system diagram also includes the interconnections between the partitioned schematics.

CS5330A/31A Analog to Digital Converter

A description of the CS5330A/31A is included in the CS5330A/31A data sheet.

CS8402A Digital Audio Interface

Figure 4 shows the CS8402A circuitry which implements AES/EBU, S/PDIF and EIAJ CP-340 digital audio interface standards. The CS8402A circuit is hardware configured for consumer mode. SW2 provides 8 DIP switches to select various modes and bits for the CS8402A, Tables 4-5. See the CS8401A/CS8402A data sheet for detailed information on the operation of the CS8402A and the digital audio standards. The operation of the CS8402A and a discussion of the digital audio interface are included in the 1994 *Crystal Semiconductor Audio Data Book*.

CS8402A Data Format

The CS8402A data format can be set with jumpers M0, M1, and M2. These formats are shown in the CS8402A datasheet found in the 1994 *Crystal Semiconductor Audio Data Book*. The format selected must be compatible with the corresponding data format of the CS5330A/31A shown in Figures 2 and 3 of the CS5330A/31A datasheet. The default settings for M0-M2 on the evaluation board are given in Tables 2 and 3. The compatible data formats for the CS8402A and CS5330A/31A are:

CS8402A format 1;CS5330A

CS8402A format 4;CS5331A

Analog input buffer

The recommended input filter required for the CS5330A/31A has been combined with a unity gain input buffer (see Figure 2). The analog input filter uses a Motorola MC33202 single supply, dual op-amp.

Power Supply Circuitry

Power is supplied to the evaluation board by two binding posts (GND, +5V), Figure 6. The +5V input supplies power to the +5 Volt digital circuitry (VD+), and the +5V analog circuitry (VA+). The analog supply is derived from the +5V binding post through a ferrite bead.

Input/Output for Clocks and Data

The evaluation board has been designed to allow the interface to external systems via the 10-pin CLOCK I/O header, HDR2. This header allows the evaluation board to accept externally generated clocks. The schematic for the clock/data I/O is shown in Figure 5. The 74HC243 transceiver functions as an I/O buffer where the MASTER/SLAVE jumper determines if the transceiver operates as a transmitter or receiver.

The transceiver operates as a transmitter with the MASTER/SLAVE jumper in the MASTER position. LRCK, SDATA, and SCLK from the CS5330A/31A will be available on HDR2. HDR22 must be in the 0 position and HDR23 must be in the 1 position for MCLK to be an output and to avoid bus contention on MCLK.

The transceiver operates as a receiver with the MASTER/SLAVE jumper in the SLAVE position. LRCK and SCLK on HDR2 become inputs. However, the recommended mode of operation is to generate MCLK on the evaluation board with HDR23 in the 0 position and HDR22 in the 1 position. These default settings allow MCLK to be an output, with LRCK and SCLK as inputs. MCLK is always an output from the evaluation board.

Grounding and Power Supply Decoupling

The CS5330A/31A requires careful attention to power supply and grounding arrangements to optimize performance. Figure 2 shows the recommended power arrangements. The CS5330A/31A is positioned over the analog ground plane, near the digital/analog ground plane split, to minimize the distance that the clocks travel. The series resistors are present on the clock lines to reduce the effects of transient currents when driving a capacitive load in master mode, and reduce clock overshoot when applying external clocks to the CS5330A/31A in slave mode.

This layout technique is used to minimize digital noise and to insure proper power supply matching/sequencing. The decoupling capacitors are located as close to the CS5330A/31A as possible. Extensive use of ground plane fill on both the analog and digital sections of the evaluation board yield large reductions in radiated noise effects.

CONNECTOR	INPUT/OUTPUT	SIGNAL PRESENT
+5V	input	(VD+) for CS8402A and digital section (VA+) for CS5330A/31A and Analog input filter op-amp
GND	input	ground connection from power supply
AINL	input	left channel analog input
AINR	input	right channel analog input
MCLK, SCLK, LRCK, SDATA	input/output	I/O for master, serial, left/right clocks, and serial DATA
Digital Output	output	digital audio interface output via coax
Optical Output	output	digital audio interface output via optical

Table 1. System Connections

JUMPER	PURPOSE	POSITION	FUNCTION SELECTED
HDR1	CS5330A/31A SCLK Selection for CS8402A	*5330A	CS5330A Selected
		5331A	CS5331A Selected
HDR10	Master/Slave Mode Selection	*High Low	MASTER Mode SLAVE Mode
HDR9	Selects source of system clocks	*High Low	MASTER Mode (5330A Clocks) SLAVE Mode (External Clocks)
HDR22 HDR23	Clock I/O	*0 *1	See <i>Input/Output for Clocks and Data</i> section of text
HDR6	Selects 256× or 512× MCLK for CS8402A	*256 512	See CS8402A data sheet for details
HDR5 (M2) HDR4 (M1) HDR3 (M0)	CS8402A mode select	*Low *Low *High	See CS8402A data sheet for details

* Default setting from factory

Table 2. CDB5330A Jumper Selectable Options

JUMPER	PURPOSE	POSITION	FUNCTION SELECTED
HDR1	CS5330A/31A SCLK Selection for CS8402A	5330A	CS5330A Selected
		*5331A	CS5331A Selected
HDR10	Master/Slave Mode Selection	*High Low	MASTER Mode SLAVE Mode
HDR9	Selects source of system clocks	*High Low	MASTER Mode (5331A Clocks) SLAVE Mode (External Clocks)
HDR22 HDR23	Clock I/O	*0 *1	See <i>Input/Output for Clocks and Data</i> section of text
HDR6	Selects 256× or 512× MCLK for CS8402A	*256 512	See CS8402A data sheet for details
HDR5 (M2) HDR4 (M1) HDR3 (M0)	CS8402A mode select	*High *Low *Low	See CS8402A data sheet for details

* Default setting from factory

Table 3. CDB5331A Jumper Selectable Options

Switch#	0=Closed, 1=Open	Comment
3	PRO=0	Consumer Mode C0=0
1,4	FC1, FC0	C24,C25,C26,C27 - Sample Frequency
	0 0 *0 1 1 0 1 1	0000 - 44.1 kHz 0100 - 48 kHz 1100 - 32 kHz 0000 - 44.1 kHz, CD Mode
2	C3	C3,C4,C5 - Emphasis (1 of 3 bits)
	*1 0	000 - None 100 - 50/15 μs
5	C2	C2 - Copy/Copyright
	1 *0	0 - Copy Inhibited/Copyright Asserted 1 - Copy Permitted/Copyright Not Asserted
6	C15	C15 - Generation Status
	1 *0	0 - Definition is based on category code. 1 - See CS8402A Data Sheet, App. A
8,7	C8, C9	C8-C14 - Category Code (2 of 7 bits)
	1 1 1 0 0 1 *0 0	0000000 - General 0100000 - PCM encoder/decoder 1000000 - Compact Disk - CD 1100000 - Digital Audio Tape - DAT

* Default setting from factory

Table 4. CS8402A Switch Definitions - Consumer Mode

Switch#	0=Closed, 1=Open	Comment
3	PRO=0	Professional Mode C0=1(default)
1	CRE	Local Sample Address Counter & Reliability Flags
default	0 1	Disabled Internally Generated
2,5	C6, C7	C6,C7 - Sample Frequency
default	1 1 1 0 0 1 0 0	00 - Not Indicated - Default to 48 kHz 01 - 48 kHz 10 - 44.1 kHz 11 - 32 kHz
4	C1	C1 - Audio
default	1 0	0 - Normal Audio 1 - Non-Audio
6	C9	C8,C9,C10,C11 - Channel Mode (1 of 4 bits)
default	1 0	0000 - Not indicated - Default to 2-channel 0100 - Stereophonic
8,7	EM1, EM0	C2,C3,C4 - Emphasis (2 of 3 bits)
default	1 1 1 0 0 1 0 0	000 - Not Indicated - default to none 100 - No emphasis 110 - 50/15 μs 111 - CCITT J.17

Table 5. CS8402A Switch Definitions - Professional Mode

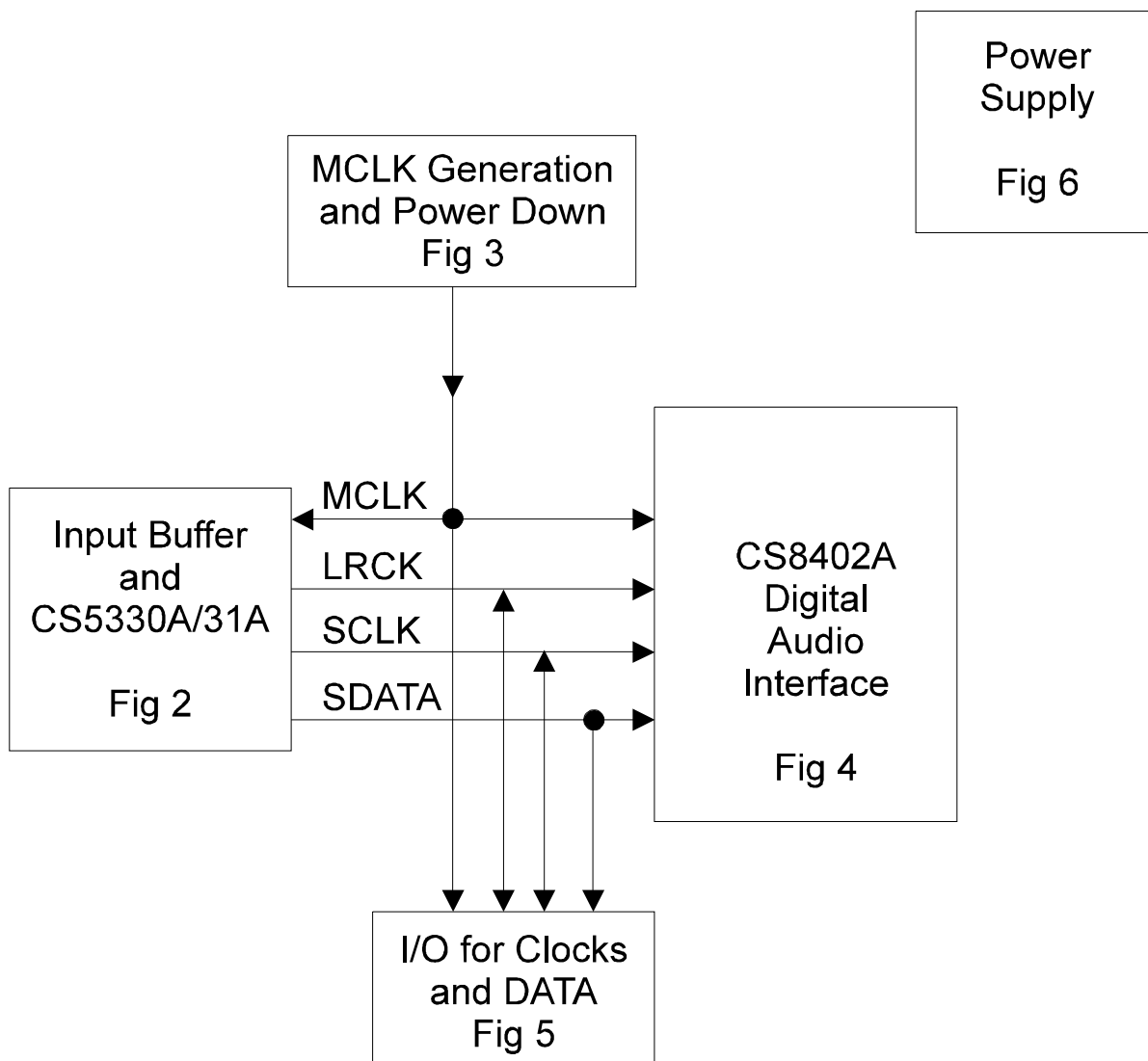

Figure 1. System Block Diagram and Signal Flow

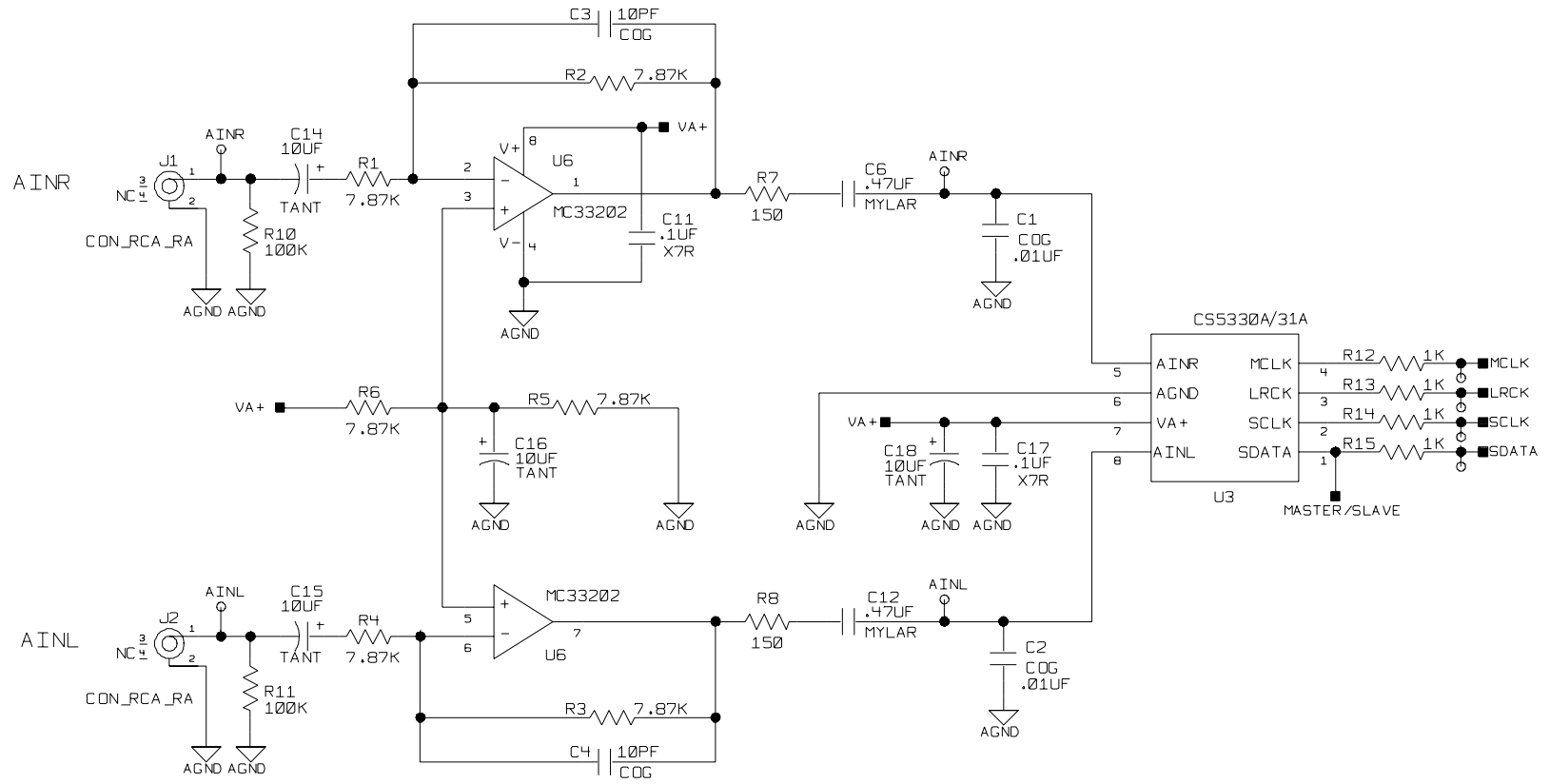

Figure 2. CS5330A/31A and Connections

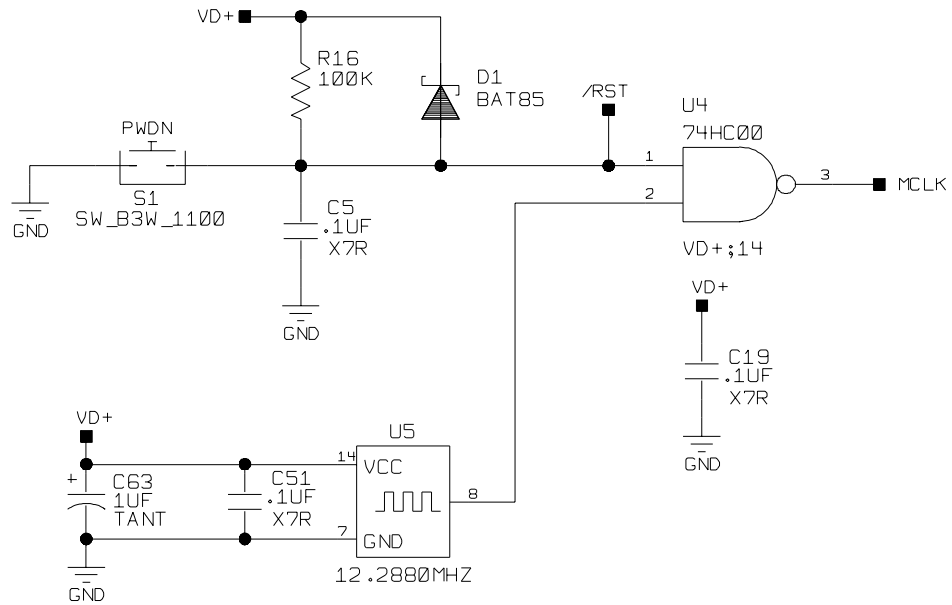

Figure 3. MCLK Generation and Power Down

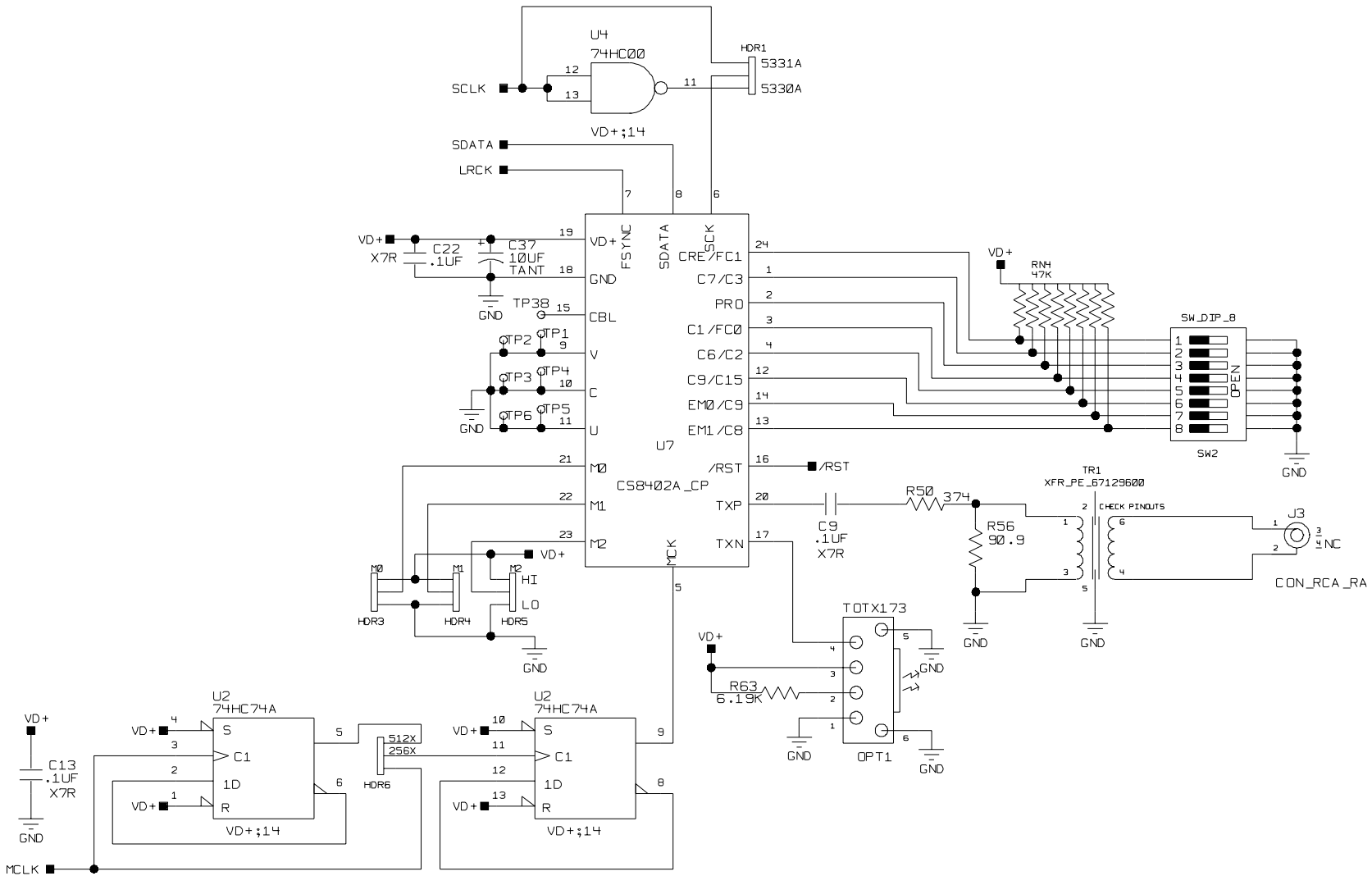

Figure 4. CS8402A Digital Audio Transmitter Connections

Optional Toshiba Part TOTX123 available through Insight Electronics
 Schott Corp. Transformer Part 121960-602 available through Schott Corp., Wayzata, MN.

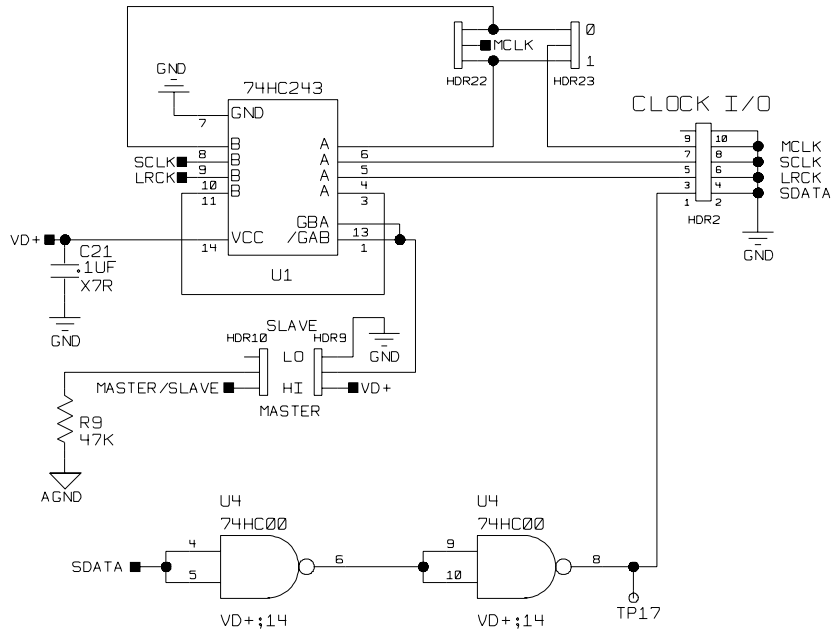

Figure 5. I/O Interface for Clocks and Data

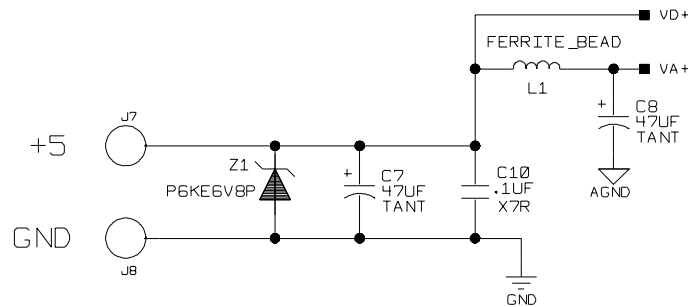

Figure 6. Power Supply

**CRYSTAL SEMICONDUCTOR
CDB5330A REV-A**

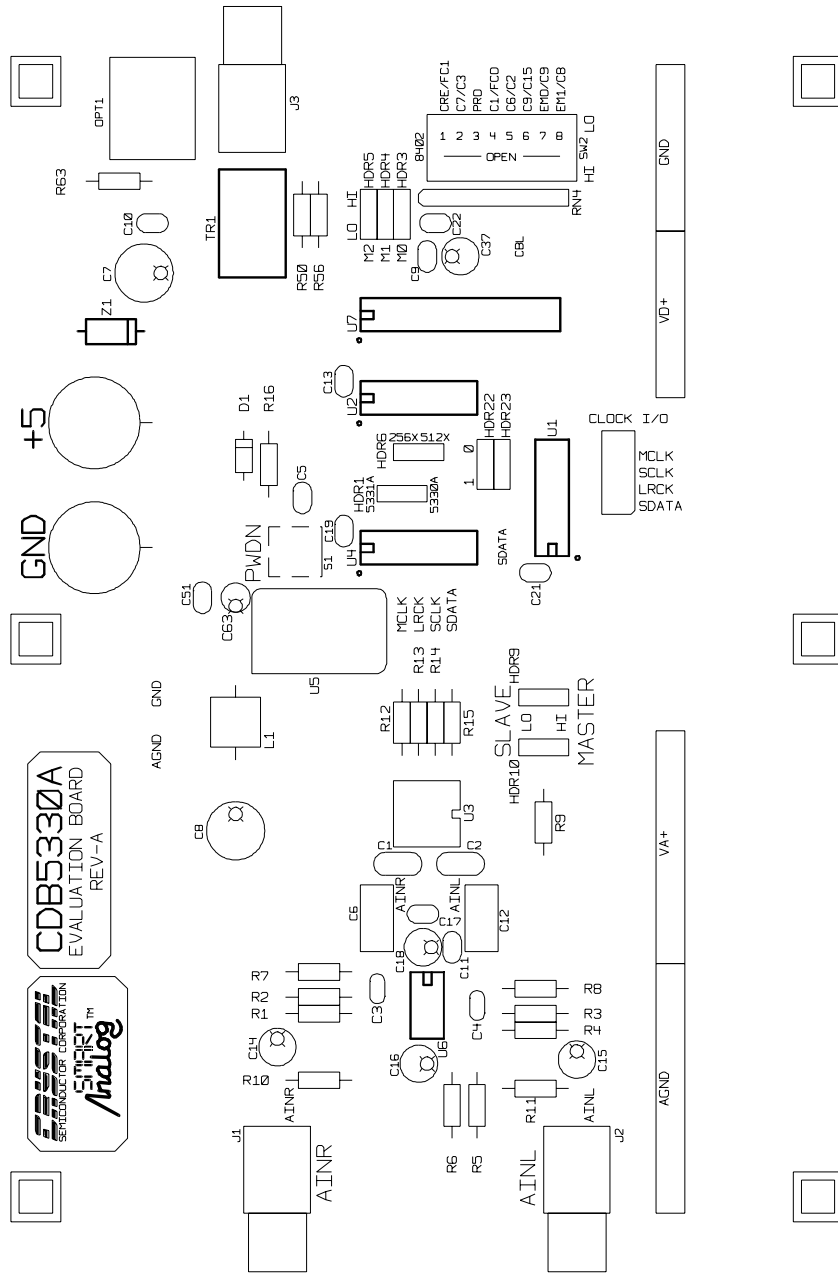
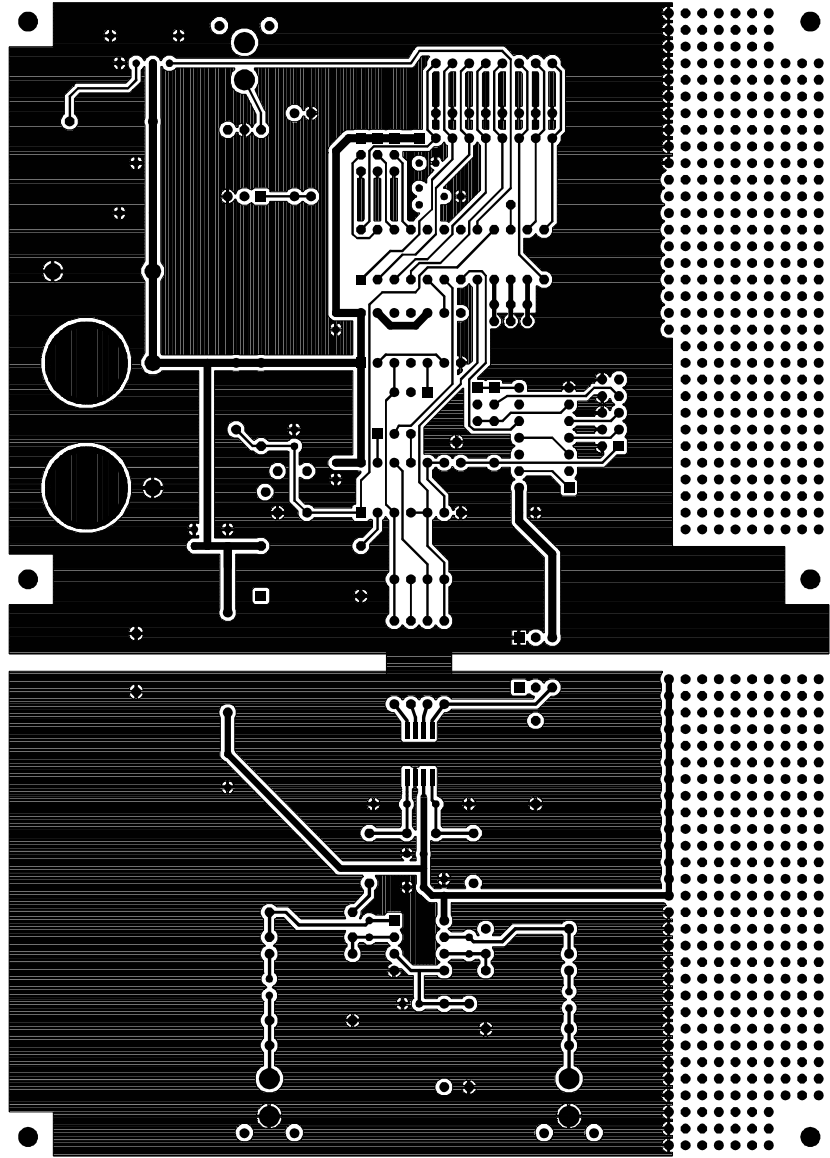

Figure 7. CDB5330A/31A Component Side Silkscreen

CRYSTAL SEMICONDUCTOR
CDB5330A REV-A



TOPSIDE

Figure 8. CDB5330A/31A Component Side (top)

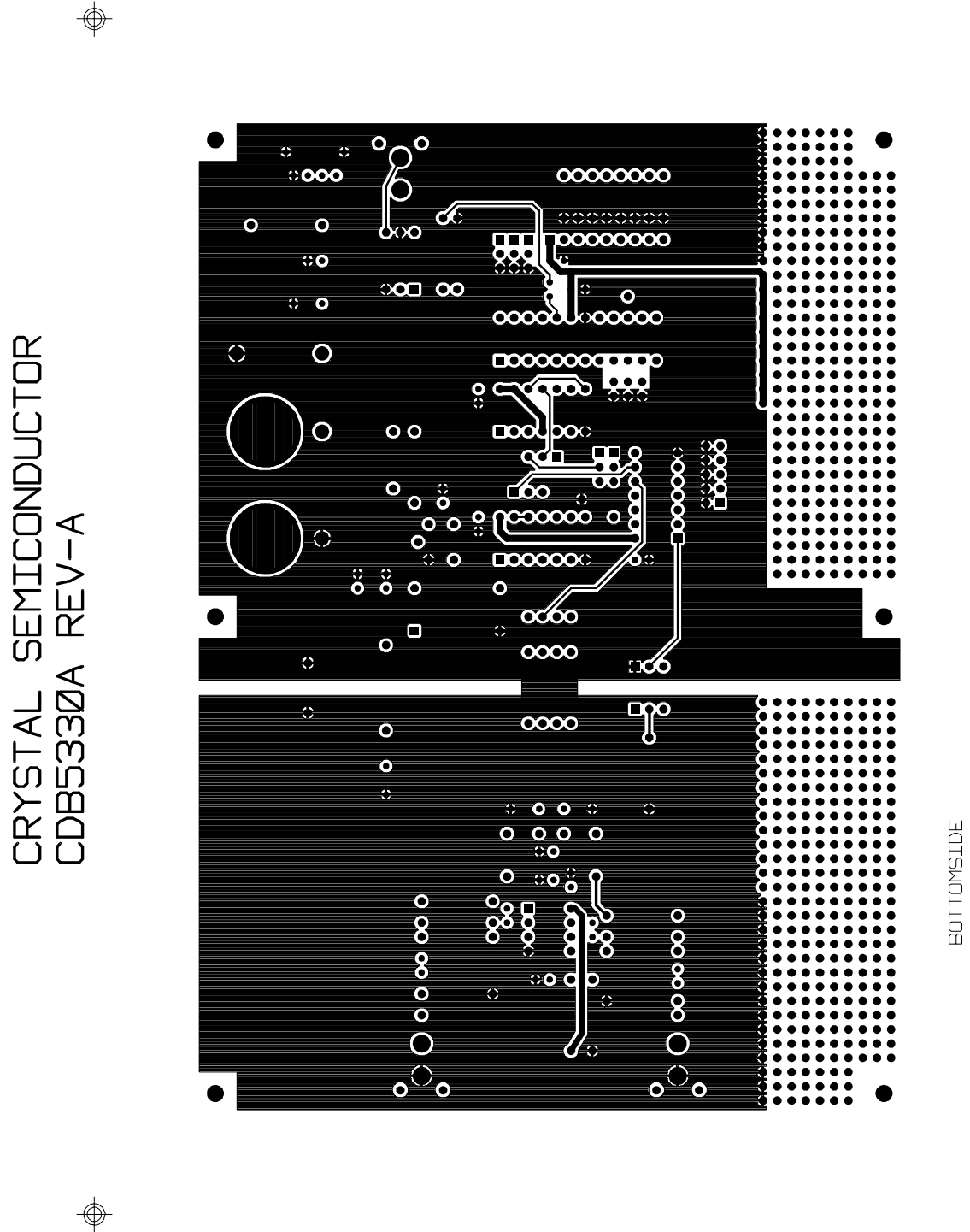

Figure 9. CDB5330A/31A Solder Side (bottom)

SMART
Analog™