

Evaluation Board for CS8130

Features

- Designed to conform to IrDA Physical Layer Specification
- Interfaces to PC Serial Port
- Operates from +2.7 V to 5.5 V Power Supply
- Includes Evaluation Software

Description

The CDB8130 evaluation board allows fast and easy evaluation of the CS8130 infrared transceiver. The board contains an RS-232 level shifter and DB-9 serial connector to allow easy interfacing to a standard PC serial (COM) port.

Additionally, the board is shipped with a complete set of diagnostic and test software, as well as the Infrared Data Association Link Access Protocol (IrLAP) reference code.

ORDERING INFORMATION

CDB8130

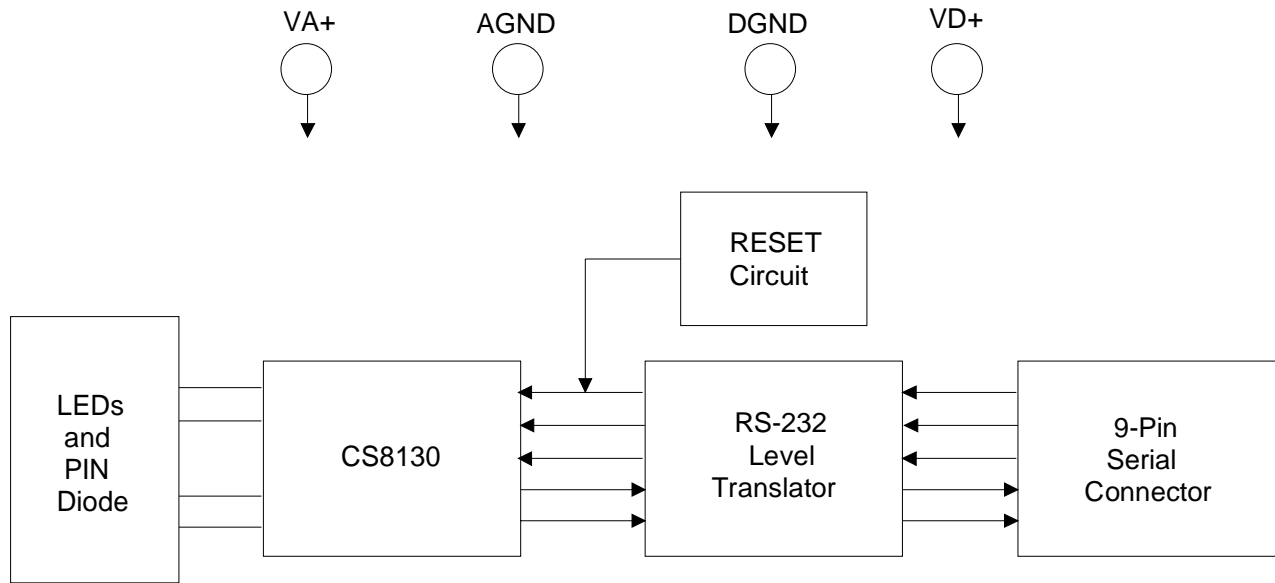

Preliminary Product Information

This document contains information for a new product. Cirrus Logic reserves the right to modify this product without notice.

CS8130 INFRARED TRANSCEIVER

The CDB8130 provides an example application of the CS8130 infrared transceiver. This application is similar to an IR pod system that is designed to plug into any standard RS-232 port, like the COM port on the back of an IBM-compatible PC, to provide an easy-to-use infrared interface.

Additionally, the board allows for easy interfacing directly to the CS8130 through stake header J11 allowing other applications to be easily realized. Figure 1 shows the CS8130 and RS-232 level translator connections.

A description of the CS8130 including register definitions, control pin assignments, and other useful information can be found in the CS8130 data sheet.

Power Supply Circuitry and Grounding

Figure 2 shows the power supply configuration of the evaluation board. Power is supplied to the board by two terminal blocks and a DC power jack, J21, J22, and J23 (DCPWR). To operate the board from a single power supply, stake jumper J20 must be installed. In this configuration, power should be supplied to the board through the VD+/DGND terminal block (J21) or the DCPWR jack (J23).

A 3.3V regulator, U5, is supplied on the board. To use this regulator, stake jumper J2 (USE REG) should be installed. To bypass the regulator, J1 (NO REG) should be installed.

To isolate the power supply driving the CS8130 from the supply powering the rest of the circuitry, remove J20, and feed the CS8130's power supply into the VA+/AGND terminal block (J22). The rest of the circuit should be powered through either the VD+/DGND terminal block (J21) or the DCPWR jack (J23).

Using the on-board voltage regulator, the eval board may be powered from any DC voltage between +4V and +6.5V. If the voltage regulator is bypassed, the acceptable operating voltage is be-

tween +2.7V and +5.5V (defined by the power supply requirements of the CS8130.)

The evaluation board is split into two ground planes, an analog plane and a digital plane. The CS8130 and IR components reside on the analog plane, and the RS-232 level translator, reset circuit, and status indicator circuitry lie over the digital ground plane. The ground planes are connected in exactly one place at jumper J31, located near the power supply connections.

Reset Circuit

Figure 3 shows the power-up and user-activated reset circuit. As shipped from the factory, this circuit is not used. The $\overline{\text{RESET}}$ signal is instead supplied by the RS-232 interface signal $\overline{\text{RTS}}$. This configuration allows the CS8130 to be reset under software control.

To derive the reset function from the power-up/manual reset circuit instead, remove stake jumper J9 (RTS) and install stake jumper J12 ($\overline{\text{RESETSW}}$). These jumpers are shown in Figure 1.

Optical Interface

The CDB8130 is shipped with Temic and Hewlett-Packard IR components installed. The receiver PIN diode is Temic model BPV 22 NF. Transmit LED D5 is a Hewlett-Packard HSDL-4220, and D6 is a Temic TSHA5502.

These components are not soldered in place. Instead, they are held by gold-plated pins. These pins allow for any insertion and removal of other IR components for performance and compatibility evaluation.

The default configuration for the transmitter circuit has one LED per output driver. One or both LEDs can be active at the same time by programming the appropriate register in the CS8130, allowing software to control the transmitter output power.

Additionally, the transmit drivers on the CS8130 can be connected in parallel to share current. This

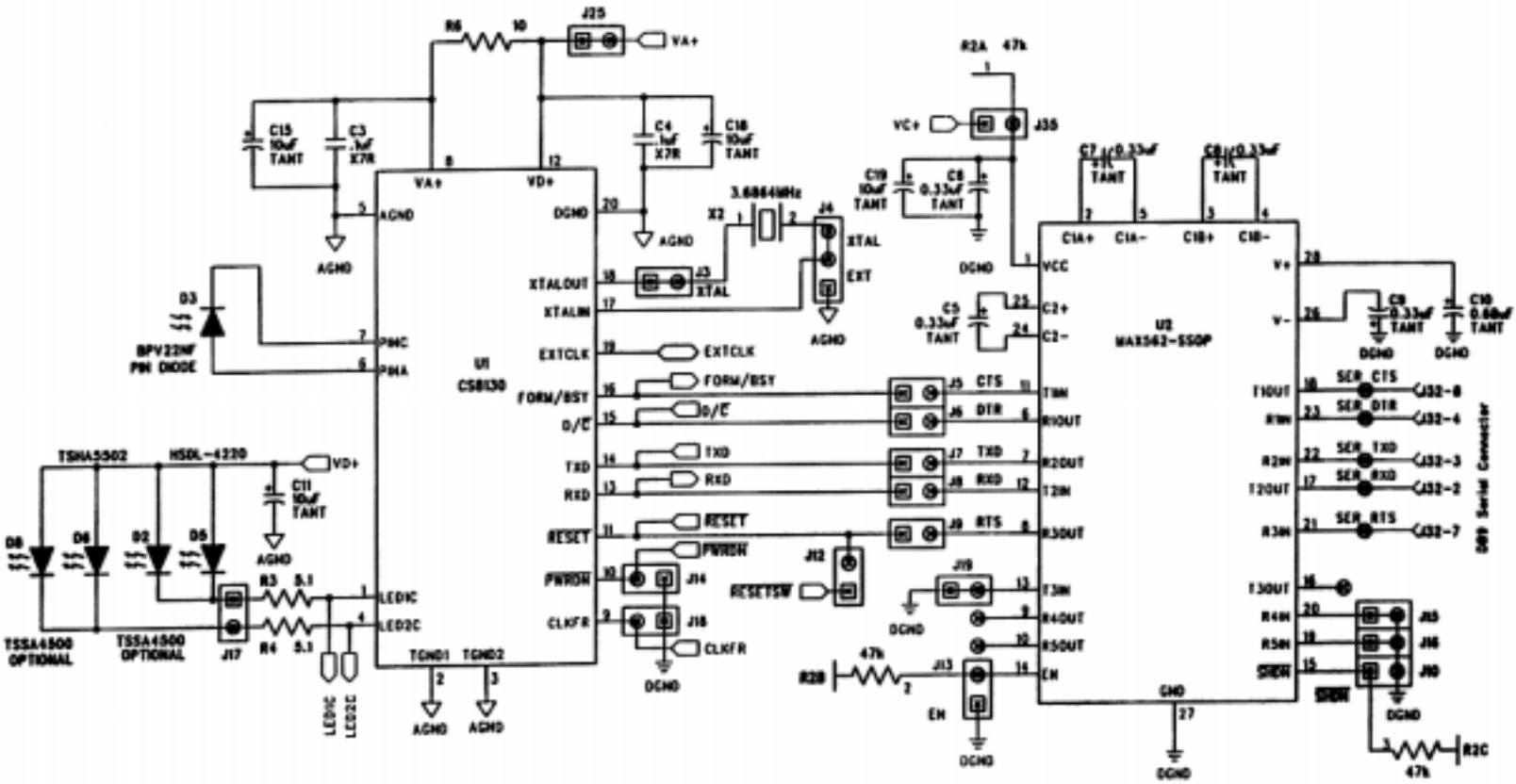

Figure 1. CS8130 and RS-232 Level Translator

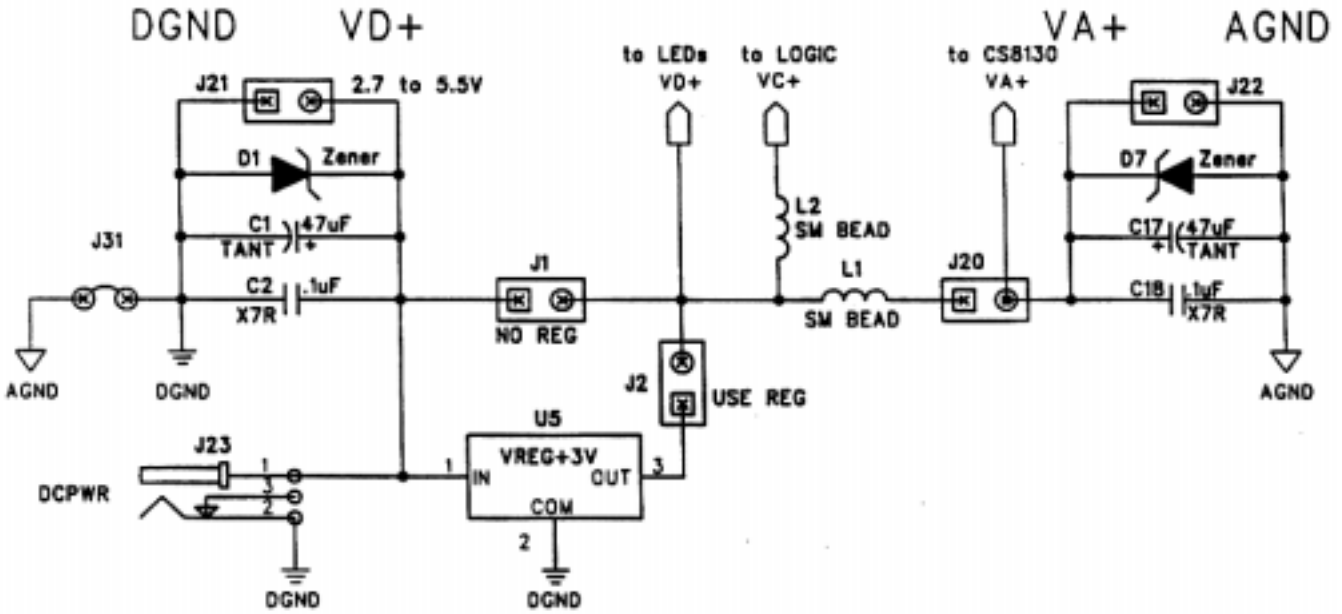

Figure 2. Power Supply Circuitry

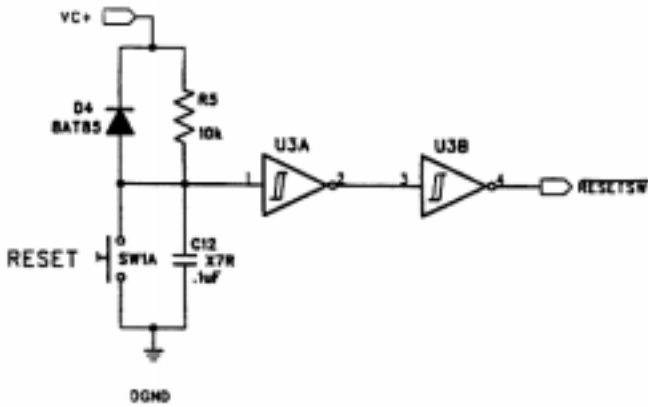

Figure 3. Reset Circuit

allows systems using only one LED to operate with a much higher drive current than can be sourced by using a single driver. To connect the transmitter drivers in this way, install jumper J17.

The LED transmitter driver resistors (R3 and R4) are optimized for a power supply voltage of 3.3V. For operation at voltages greater than this, the values of these resistors must be increased.

RS-232 Interface

The CDB8130 is designed to connect to any standard RS-232 port through the female DB-9 connector marked "RS-232." The MAX562 (U2) supplies the voltage level translation function, taking the $\pm 12V$ RS-232 levels and translating them to standard CMOS logic levels.

Table 1 shows the default mapping of UART signals to CS8130 pins.

| CS8130 Pin | UART Signal | Direction |
|--------------------|------------------|-----------|
| RXD | RXD | to UART |
| TXD | TXD | to CS8130 |
| FORM/BSY | \overline{CTS} | to UART |
| D/ \overline{C} | \overline{DTR} | to CS8130 |
| \overline{RESET} | \overline{RTS} | to CS8130 |

Table 1. CS8130-to-UART Connections

Header Interface

If desired, the RS-232 level translator can be removed from the circuit. The signals are disconnected by removing jumpers J5, J6, J7, J8, and J9.

Removing J35 will disconnect power from the level translator.

All the digital signals on the CS8130, FORM/BSY, D/C, TXD, RXD, EXTCLK, $\overline{\text{RESET}}$, $\overline{\text{PWRDN}}$, and CLKFR can be accessed directly from header J11. All digital input pins are tied to 47 k Ω pull-up resistors through resistor set R1.

Clock Selection

The clock for the CS8130 can be supplied via a crystal tied between XTALIN and XTALOUT (the default configuration on the evaluation board) or by an external clock supplied through the EXTCLK pin.

To operate the CS8130 from an external clock source, cut the trace under J3 (XTAL), and the (XTAL) part of J4, then connect the center pin of J4 to the edge pin marked EXT.

Note: the EXTCLK pin on the CS8130 can be either an input or an output. If the CS8130 is being clocked from a crystal, EXTCLK is an output. If no crystal is present, EXTCLK is an input. This determination of direction is made while $\overline{\text{RESET}}$ is asserted.

The CS8130 can be operated from either a 3.6864 MHz or a 1.8432 MHz clock source. If operating from a 3.6864 MHz source, jumper J18 (CLKFR) must be installed. This brings the CLKFR pin on the CS8130 low. If operating from a 1.8432 MHz source, jumper J18 should be removed.

Power Down

Jumper J14 ($\overline{\text{PWRDN}}$) controls the state of the $\overline{\text{PWRDN}}$ pin on the CS8130. $\overline{\text{PWRDN}}$ is asserted when J14 is installed.

Status Indicator LEDs

Key digital signals on the CS8130 are displayed on indicator LEDs U6 (U8) and U7 (U9), shown schematically in Figure 4. Because these LEDs are

driven through inverters, the interpretation of what it means when a LED is lit can be confusing. Table 2 should help clarify this.

| Name | LED On means. . . |
|---------------------------|--------------------------------------|
| LED1C | Transmitter #1 active |
| LED2C | Transmitter #2 active |
| $\overline{\text{PWRDN}}$ | Power down asserted |
| $\overline{\text{RESET}}$ | Reset asserted |
| RXD | Data being received by the CS8130 |
| TXD | Data being transmitted to the CS8130 |
| D/C | CS8130 in Control Mode |
| FORM/BSY | Auto detect ASK/TV TX ready |

Table 2. LED Indicator Meanings

Software

The CDB8130 evaluation kit comes equipped with software that can be used to evaluate and test the CS8130. Additional software is currently under development.

See the documentation supplied with the CDB8130 evaluation kit for instructions on how to use the software.

Software updates and new releases can be downloaded from the Crystal BBS. Contact the factory for details.

Schematic & Layout Review Service

Confirm Optimum
Schematic & Layout
Before Building Your Board.

For Our Free Review Service
Call Applications Engineering.



C a l l : (5 1 2) 4 4 5 - 7 2 2 2

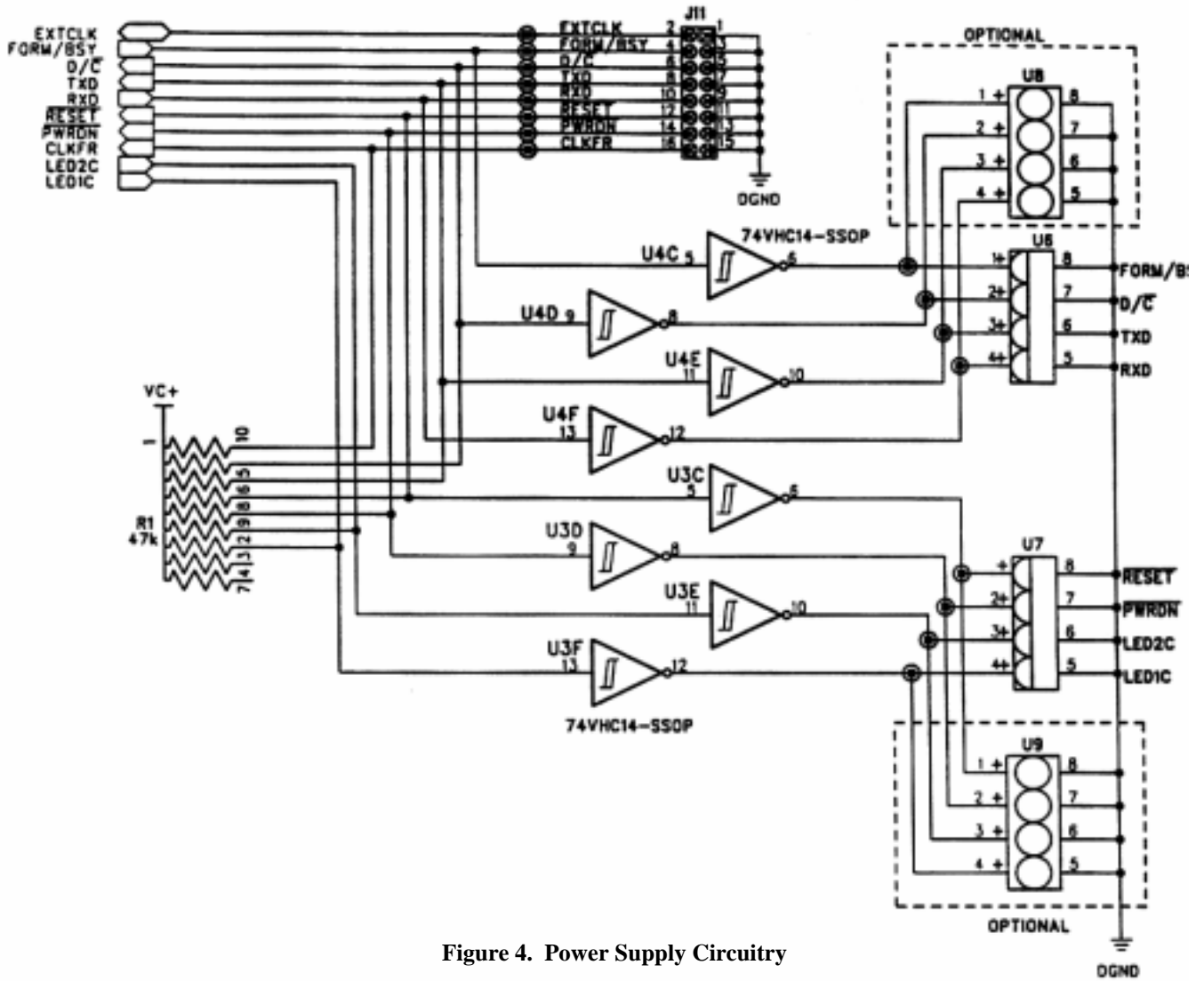

Figure 4. Power Supply Circuitry

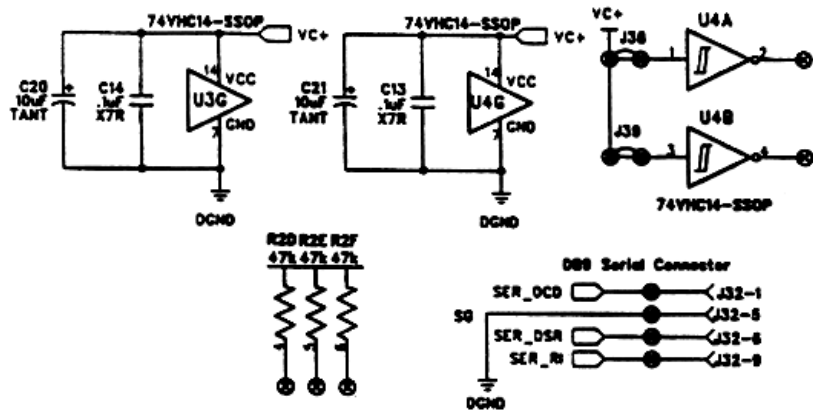

Figure 5. Unused Gates and Resistors

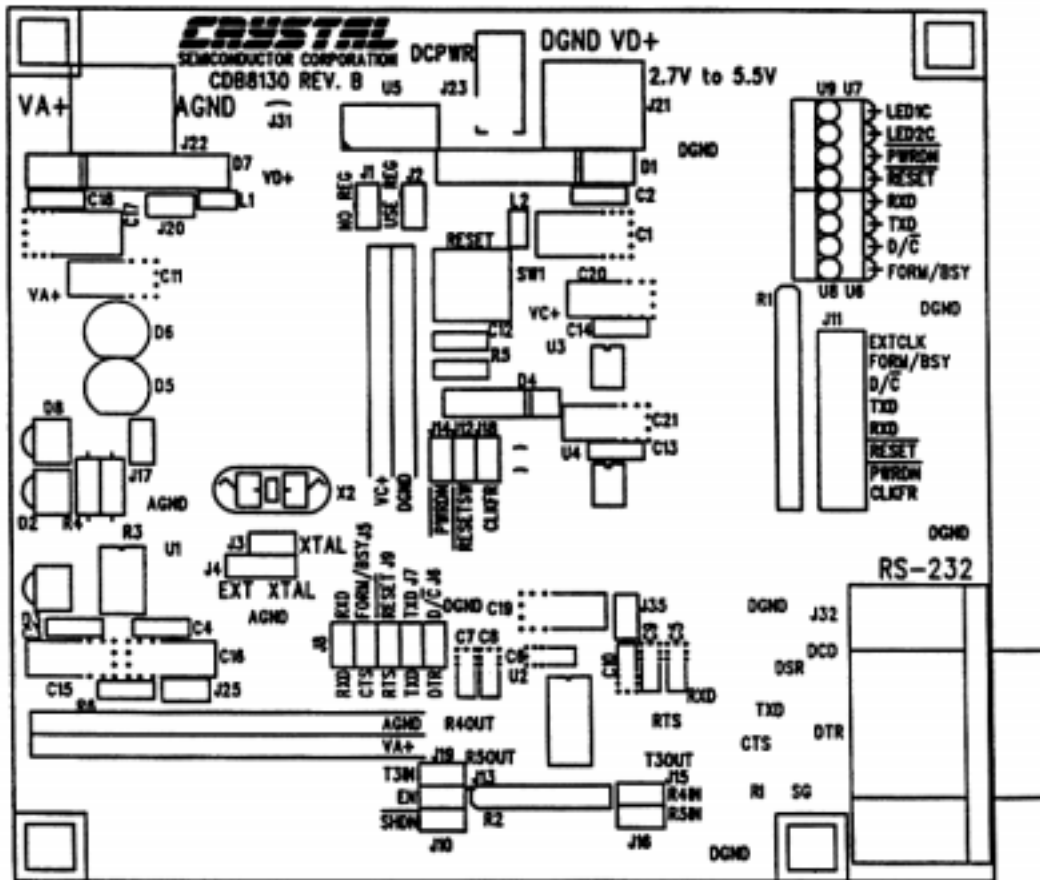

Figure 6. Component-side Silkscreen (Not to Scale)

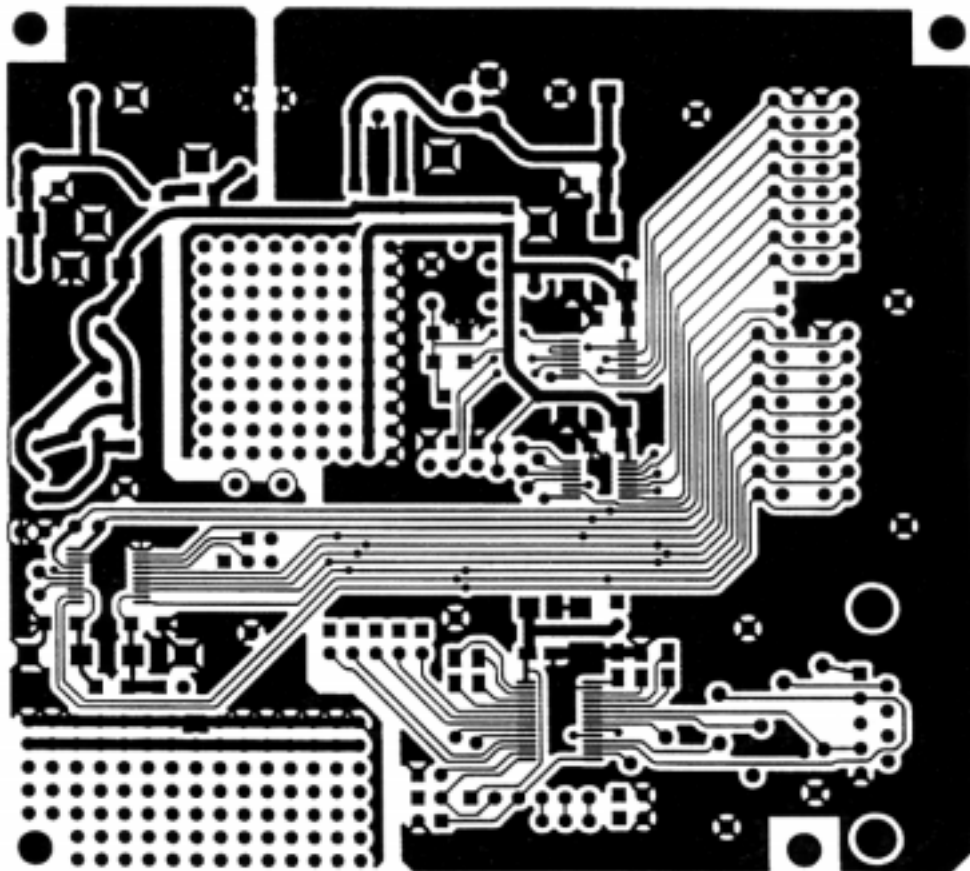

Figure 7. Component-side Trace Layer (Not to Scale)

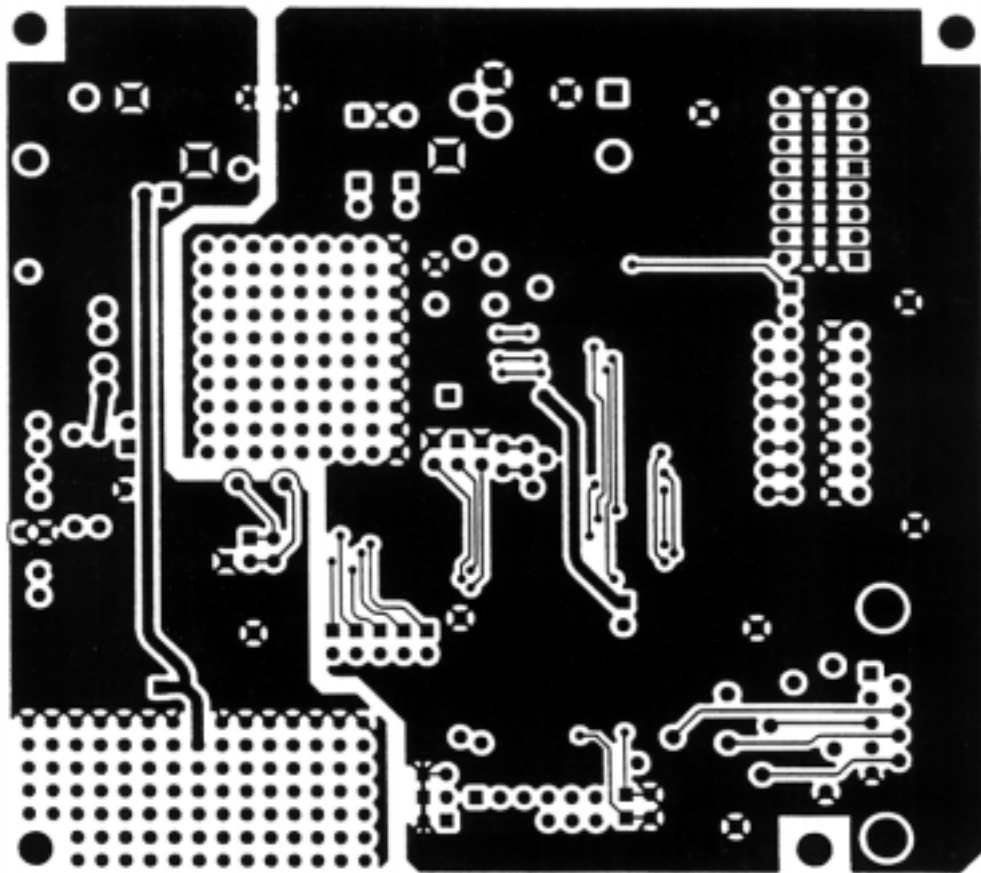

Figure 8. Solder-side Trace Layer (Not to Scale)



Contacting Cirrus Logic Support

For a complete listing of Direct Sales, Distributor, and Sales Representative contacts, visit the Cirrus Logic web site at: <http://www.cirrus.com/corporate/contacts/>

Preliminary product information describes products which are in production, but for which full characterization data is not yet available. Advance product information describes products which are in development and subject to development changes. Cirrus Logic, Inc. has made best efforts to ensure that the information contained in this document is accurate and reliable. However, the information is subject to change without notice and is provided "AS IS" without warranty of any kind (express or implied). No responsibility is assumed by Cirrus Logic, Inc. for the use of this information, nor for infringements of patents or other rights of third parties. This document is the property of Cirrus Logic, Inc. and implies no license under patents, copyrights, trademarks, or trade secrets. No part of this publication may be copied, reproduced, stored in a retrieval system, or transmitted, in any form or by any means (electronic, mechanical, photographic, or otherwise) without the prior written consent of Cirrus Logic, Inc. Items from any Cirrus Logic website or disk may be printed for use by the user. However, no part of the printout or electronic files may be copied, reproduced, stored in a retrieval system, or transmitted, in any form or by any means (electronic, mechanical, photographic, or otherwise) without the prior written consent of Cirrus Logic, Inc. Furthermore, no part of this publication may be used as a basis for manufacture or sale of any items without the prior written consent of Cirrus Logic, Inc. The names of products of Cirrus Logic, Inc. or other vendors and suppliers appearing in this document may be trademarks or service marks of their respective owners which may be registered in some jurisdictions. A list of Cirrus Logic, Inc. trademarks and service marks can be found at <http://www.cirrus.com>.