

APPLICATION NOTE

CS4923/4/5/6/7/8/9 HARDWARE USER'S GUIDE

Contents

- Host Communication (Serial and Parallel Host Communication)
- Boot Procedures for Host Boot and Autoboot
- Resetting the CS492x
- Connecting External Memory (Using Paged and Non-Paged Memory)
- Understanding Configuration Messages
- Input & Output Hardware Configuration
- Pseudocode examples for SPI and I2C Communication with the CS492x
- Pseudocode Outlining a Typical Download Session with the CS492x
- Pseudocode Outlining a Typical Reset Sequence with the CS492x

Description

The CS4923/4/5/6/7/8/9 is a system on a chip solution for multi-channel audio decompression and digital signal processing. Because the device is RAM-based, a download of application software is required each time the CS4923/4/5/6/7/8/9 is powered up. This document focuses on hardware control of the chip from a functional perspective.

This document takes more of a functional approach to the hardware of the chip. An in-depth description of communication, boot procedure, external memory and the hardware configuration are given in this document. This document will be valuable to both the hardware designer and the system programmer.

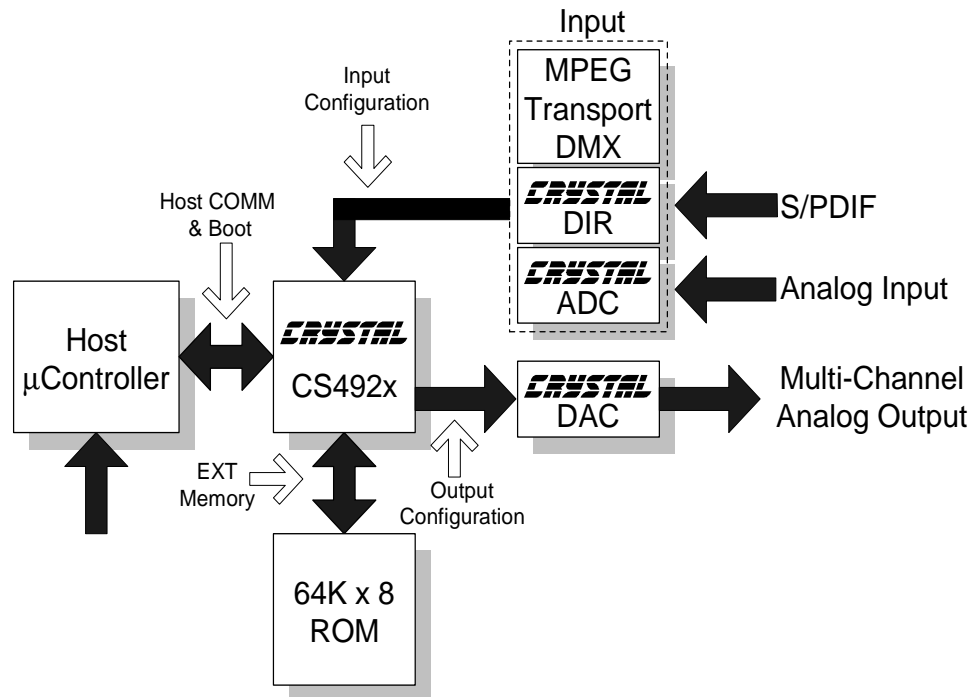



TABLE OF CONTENTS

1. OVERVIEW	5
1.1 Multi-Channel Decoder Family of Parts	5
1.2 Document Strategy	6
1.2.1 Hardware Documentation	6
1.2.2 CS4923/4/5/6/7/8/9 Application Code User's Guides	6
1.3 Using the CS4923/4/5/6/7/8/9	7
2. HOST COMMUNICATION	8
2.1 Serial Communication	8
2.1.1 SPI Communication	8
2.1.1.1 Writing in SPI	9
2.1.1.2 Reading in SPI	9
2.1.2 I ² C Communication	12
2.1.2.1 Writing in I ² C	12
2.1.2.2 Reading in I ² C	13
2.1.3 INTREQ Behavior: A Special Case	14
2.2 Parallel Host Communication	17
2.2.1 Intel Parallel Host Communication Mode	18
2.2.1.1 Writing a Byte in Intel Mode	19
2.2.1.2 Reading a Byte in Intel Mode	19
2.2.2 Motorola Parallel Host Communication Mode	20
2.2.2.1 Writing a Byte in Motorola Mode	20
2.2.2.2 Reading a Byte in Motorola Mode	21
2.2.3 Procedures for Parallel Host Mode Communication	22
2.2.3.1 Control Write in a Parallel Host Mode	22
2.2.3.2 Control Read in a Parallel Host Mode	23
3. BOOT PROCEDURE & RESET	25
3.1 Host Boot	25
3.2 Autoboot	28
3.2.1 Autoboot INTREQ Behavior	31
3.3 Application Failure Boot Message	32
3.4 Resetting the CS4923/4/5/6/7/8/9	32
4. EXTERNAL MEMORY	34
4.1 Basic Memory Architecture	35
4.2 Non-Paged Memory	36
4.3 Paged Memory	36
4.4 Examples	38
4.4.1 Non-Paged Memory	38
4.4.2 32 Kilobyte Paged Autoboot Memory	39

Contacting Cirrus Logic Support

For a complete listing of Direct Sales, Distributor, and Sales Representative contacts, visit the Cirrus Logic web site at:
<http://www.cirrus.com/corporate/contacts/>

Preliminary product information describes products which are in production, but for which full characterization data is not yet available. Advance product information describes products which are in development and subject to development changes. Cirrus Logic, Inc. has made best efforts to ensure that the information contained in this document is accurate and reliable. However, the information is subject to change without notice and is provided "AS IS" without warranty of any kind (express or implied). No responsibility is assumed by Cirrus Logic, Inc. for the use of this information, nor for infringements of patents or other rights of third parties. This document is the property of Cirrus Logic, Inc. and implies no license under patents, copyrights, trademarks, or trade secrets. No part of this publication may be copied, reproduced, stored in a retrieval system, or transmitted, in any form or by any means (electronic, mechanical, photographic, or otherwise) without the prior written consent of Cirrus Logic, Inc. Items from any Cirrus Logic website or disk may be printed for use by the user. However, no part of the printout or electronic files may be copied, reproduced, stored in a retrieval system, or transmitted, in any form or by any means (electronic, mechanical, photographic, or otherwise) without the prior written consent of Cirrus Logic, Inc. Furthermore, no part of this publication may be used as a basis for manufacture or sale of any items without the prior written consent of Cirrus Logic, Inc. The names of products of Cirrus Logic, Inc. or other vendors and suppliers appearing in this document may be trademarks or service marks of their respective owners which may be registered in some jurisdictions. A list of Cirrus Logic, Inc. trademarks and service marks can be found at <http://www.cirrus.com>.

4.4.3 64 Kilobyte Paged Autoboot Memory	40
4.4.4 64 Kilobyte Paged DTS & Autoboot Memory	41
4.5 CRD4923-MEM	42
5. HARDWARE CONFIGURATION	46
5.1 Address Checking	47
5.2 Input and Output	47
5.2.1 Digital Audio Formats	47
5.2.2 Digital Input and Output Ports	49
5.2.3 Parallel Delivery of Data	50
5.2.3.1 PCM Data Write in Parallel Host Mode	50
5.2.3.2 Compressed Data Write in Parallel Host Mode	51
5.2.3.2.1 MFB Bit Example	51
5.2.3.2.2 CMPREQ Example	52
5.3 Configuration Messages	52
5.3.1 Address Checking	52
5.3.2 Input	53
5.3.2.1 Special Considerations	53
5.3.3 Output	55
5.3.3.1 Special Considerations	55
5.3.4 Creating Hardware Configuration Messages	56
6. APPENDIX A - PSEUDOCODE FOR THE CS4923/4/5/6/7/8/9 FAMILY	58
6.1 SPI Pseudocode	58
6.1.1 SPI Write Operation	58
6.1.2 SPI Read Operation	59
6.2 I ² C Pseudocode	60
6.2.1 I ² C Write Operation	60
6.2.2 I ² C Read Operation	62
6.3 Typical Download Session with the CS4923/4/5/6/7/8/9	64
6.4 Typical Reset Sequence for the CS4923/4/5/6/7/8/9	65

LIST OF FIGURES

Figure 1. SPI Write Flow Diagram.....	9
Figure 2. SPI Read Flow Diagram	10
Figure 3. SPI Timing	11
Figure 4. I ² C Write Flow Diagram	12
Figure 5. I ² C Read Flow Diagram	13
Figure 6. I ² C Timing	15
Figure 7. Intel Mode, One-Byte Write Flow Diagram	19
Figure 8. Intel Mode, One-Byte Read Flow Diagram	20
Figure 9. Motorola Mode, One-Byte Write Flow Diagram	21
Figure 10. Motorola Mode, One-Byte Read Flow Diagram	21
Figure 11. Typical Parallel Host Mode Control Write Sequence Flow Diagram.....	22
Figure 12. Typical Parallel Host Mode Control Read Sequence Flow Diagram.....	23
Figure 13. Typical Serial Boot and Download Procedure	26
Figure 14. Typical Parallel Boot and Download Procedure.....	27
Figure 15. Autoboot Memory Architecture	28
Figure 16. Autoboot Timing Diagram	29
Figure 17. Autoboot Sequence	30
Figure 18. Autoboot INTREQ Behavior.....	31
Figure 19. Performing a Reset.....	32
Figure 21. Autoboot Timing Diagram	35
Figure 22. Run-Time Memory Access.....	35
Figure 20. Basic Memory Architecture	35

Figure 23. External Memory with 64 Kilobyte Pages.....	37
Figure 24. External Memory With 32 Kbyte Pages	37
Figure 25. Non-Paged Memory	39
Figure 26. 32 Kbyte Paged memory.....	39
Figure 27. Autoboot Sequence for 32 Kbyte Paged Memory	40
Figure 28. 64 Kbyte Paged Autoboot Memory	40
Figure 29. Autoboot for 64 Kbyte paged Memory	41
Figure 30. 64 Kbyte Paged DTS/Autoboot Memory	42
Figure 31. Autoboot Sequence for DTS System using Symmetrical 64 Kilobyte Pages.....	43
Figure 32. CRD4923-MEM.....	45
Figure 33. Memory Map for CRD4923 Daughter Board.....	46
Figure 34. DTS Autoboot Flow Diagrams.....	46
Figure 35. I2S Format	48
Figure 36. Left Justified Format.....	48
Figure 37. Multi-Channel Format (M == 20)	48
Figure 38. PCM Data Write Sequence in Parallel Host Mode Flow Diagram.....	51
Figure 39. MFB Bit Status Polling Flow Diagram	52
Figure 40. CMPREQ Pin Status Polling Flow Diagram	52

LIST OF TABLES

Table 1. Serial Host Mode Configurations.....	8
Table 2. SPI Communication Signals.....	8
Table 3. I ² C Communication Signals	12
Table 4. Parallel Host Mode Configurations.....	17
Table 5. Intel Mode Communication Signals	18
Table 6. Motorola Mode Communication Signals.....	20
Table 7. Boot Write Messages	25
Table 8. Boot Read Messages	25
Table 9. Memory Interface Pins	34
Table 10. Memory and Control Requirements for the CS4923/4/5/6/7/8/9 Family.....	34
Table 11. ROM Speeds.....	36
Table 12. External Memory Configurations	38
Table 13. DAI - Digital Audio Input Port	49
Table 14. CDI - Compressed Digital Input Port	49
Table 15. DAO - Digital Audio Output Port.....	49
Table 16. Output Channel Mapping	49
Table 17. Input Data Type Configuration	53
Table 18. Input Data Format Configuration	54
Table 19. Input SCLK Polarity Configuration.....	54
Table 20. FIFO Setup Configuration	54
Table 21. Output Clock Configuration	55
Table 22. Output Data Format Configuration	55
Table 23. Output MCLK Configuration	56
Table 24. Output SCLK Configuration.....	56
Table 25. Output SCLK Polarity Configuration.....	56
Table 26. Example Values to be Sent to CS492X After Download or Soft Reset	57



1. OVERVIEW

The CS4923/4/5/6/7/8/9 is a family of system on a chip solutions for multi-channel audio decompression and digital signal processing. Since the part is RAM-based, a download of application software is required each time the CS4923/4/5/6/7/8/9 is powered up.

These parts are generally targeted at two different market segments. The broadcast market where audio/video (A/V) synchronization is required, and the outboard decoder markets where audio/video synchronization is not required. The important differentiation is the format in which the data will be received by the CS4923/4/5/6/7/8/9. In systems where A/V synchronization is required from the CS4923/4/5/6/7/8/9, the incoming data is typically PES encoded. In an outboard decoder application the data typically comes in the IEC61937 format (as specified by the DVD consortium). An important point to remember is that the CS4923/4/5/6/7/8/9 will support both environments, but different downloads are required depending on the input data type.

Broadcast applications include (but are not limited to) set top box applications, DVDs and digital TVs. Outboard decoder applications include standalone decoders and audio/video receivers. Often times a system may be a hybrid between an outboard decoder and a broadcast system depending on its functionality.

As discussed above, compressed audio can be packed in IEC61937, PES, or elementary formats depending on the decoder environment. Each format is supported by a separate download of application code. Consult the relevant Application Code User's Guide to determine which formats are supported by a particular application. A brief description of each format is presented below.

Elementary - an elementary bitstream consists only of compressed audio data (e.g., strictly the Dolby

Digital bitstream); used primarily in broadcast environments.

PES - a Packetized Elementary Stream (PES) bitstream contains the elementary compressed audio stream and additional header information which can be used for A/V synchronization; used primarily in broadcast environments.

IEC61937 - a method of packing compressed audio such that it can be delivered using a bi-phase encoded signal (e.g., S/PDIF output signal from DVD player); used primarily for outboard decoders where A/V synchronization is not required.

1.1 Multi-Channel Decoder Family of Parts

CS4923 - Dolby Digital™ Audio Decoder. The CS4923 is the original member of the family and is intended to be used if only Dolby Digital decoding is required. For Dolby Digital, post processing includes bass management, delays and Dolby Pro Logic decoding. Separate downloads can also be used to support stereo to 5.1 channel effects processing and stereo MPEG decoding.

CS4924 - Dolby Digital™ Source Product Decoder. The CS4924 is the stereo version of the CS4923 designed for source products such as DVD, HDTV, and set-top boxes. Separate downloads are available for stereo decode of Dolby Digital and MPEG audio.

CS4925 - International Multi-Channel DVD Audio Decoder. The CS4925 supports both Dolby Digital and MPEG-2 multi-channel formats. For both Dolby Digital and MPEG-2 multi-channel, post processing includes bass management and Dolby Pro Logic decoding. Separate downloads are available for decode of Dolby Digital and MPEG audio. Another code load can be used to support stereo to 5.1 channel effects processing.

CS4926 - DTS/Dolby® Multi-Channel Audio Decoder. The CS4926 supports both Dolby Digital and DTS, or Digital Theater Surround. For Dolby Digital, post processing includes bass management

and Dolby Pro Logic. The Dolby Digital code and DTS code take separate code downloads. Separate downloads can also be used to support stereo to 5.1 channel effects processing and stereo MPEG decoding.

CS4927 - MPEG-2 Multi-Channel Decoder. The CS4927 supports MPEG-2 multi-channel decoding and should be used in applications where Dolby Digital decoding is not necessary. For MPEG-2 multi-channel decoding, post processing includes bass management and Dolby Pro Logic decoding. Another code load can be used to support stereo to 5.1 channel effects processing.

CS4928 - DTS Multi-Channel Decoder. The CS4928 supports DTS multi-channel decoding and should be used in applications where Dolby Digital decoding is not necessary. For DTS multi-channel decoding, post processing includes bass management. Separate downloads can also be used to support stereo to 5.1 channel effects processing and stereo MPEG decoding.

CS4929 - AAC 2-Channel, (Low Complexity) and MPEG-2 Stereo Decoder. The CS4929 is capable of decoding both 2-channel AAC and MPEG-2 audio. The CS4929 supports elementary and PES formats.

1.2 Document Strategy

Multiple documents are needed to fully define, understand and implement the functionality of the CS4923/4/5/6/7/8/9. They can be split up into two basic groups: hardware and application code documentation. It should be noted that hardware and application code are co-dependent and one can not successfully use the part without an understanding of both. The ‘ANXXX’ notation denotes the application note number under which the respective user’s guide was released.

1.2.1 Hardware Documentation

CS4923/4/5/6/7/8/9 Family Data Sheet - This document describes the electrical characteristics of

the device from timing to base functionality. This is the hardware designers tool to learn the part’s electrical and systems requirements.

AN115 - CS4923/4/5/6/7/8/9 Hardware User’s Guide - describes the functional aspects of the device. An in depth description of communication, boot procedure, external memory and hardware configuration are given in this document. This document will be valuable to both the hardware designer and the system programmer.

1.2.2 CS4923/4/5/6/7/8/9 Application Code User’s Guides

The following application notes describe the application codes used with the CS4923/4/5/6/7/8/9. Whenever an application code user’s guide is referred to, it should be assumed that one or more of the below documents are being referenced. The following list covers currently released application notes. This list will grow with each new application released. For a current list of released user’s guides please see www.crystal.com and search for the part number.

AN120 - Dolby Digital User’s Guide for the CS4923/4/5/6. This document covers the features available in the Dolby Digital code including delays, pink noise, bass management, Pro Logic, PCM pass through and Dolby Digital processing features. Optional appendices are available that document code for Dolby Virtual, Q-Surround and VMaX.

AN121 - MPEG User’s Guide for the CS4925. This document covers the features available in the MPEG Multi-Channel code including delays, bass management, Pro Logic, and MPEG processing features.

AN122 - DTS User’s Guide for the CS4926, CS4928. This document covers the features available in the DTS code including bass management and DTS processing features.



AN123 - Surround User's Guide for the CS4923/4/5/6/7/8. This code covers the different Stereo PCM to surround effects processing code. Optional appendices are available that document Crystal Original Surround, Circle Surround and Logic 7.

AN140 - Broadcast Systems Guide for the CS4923/4/5/6/7/8/9. This guide describes all application code (e.g. Dolby Digital, MPEG, AAC) designed for broadcast systems such as HDTV and set-top box receivers. This document also provides a discussion of broadcast system considerations and dependencies such as A/V synchronization and channel change procedures.

1.3 Using the CS4923/4/5/6/7/8/9

No matter what application is being used on the chip, the following four steps are always followed to use the CS4923/4/5/6/7/8/9 in system.

- 1) Reset and/or Download Code - Detailed information in AN115
- 2) Hardware Configuration - Detailed information in AN115
- 3) Application configuration - Detailed information in the appropriate Application Code User's guide
- 4) Kickstart - This is the "Go" command to the CS492X once the system is properly configured. Information can be found in the appropriate Application Code User's guide.

For this document, CS4923/4/5/6/7/8/9 has been replaced in certain places with CS492X for readability. Unless otherwise specified CS492X should be interpreted as applying to the CS4923, CS4924, CS4925 and CS4926.

2. HOST COMMUNICATION

The host communication port of the CS4923/4/5/6/7/8/9 is used for downloading application code to the DSP and it is used for communicating with the DSP during run-time. The CS492X supports two parallel host communication modes (Intel mode and Motorola mode) and two serial host communication modes (I²C and SPI).

Please note that when a parallel host communication mode has been selected, the external memory interface cannot be used. This constraint has two significant implications:

- *Autoboot cannot be used in a system using parallel host communication*
- *Parallel host communication modes cannot be used when processing DTS (CS4926 or CS4928)*

Each of the host communication modes supported by the CS492X family will be discussed in subsequent sections. The following information will be provided for each mode:

- How to configure the CS492X for each host communication mode
- Which pins of the CS492X must be used
- The protocol used for writing to the CS492X
- The protocol used for reading from the CS492X

2.1 Serial Communication

The CS4923/4/5/6/7/8/9 has a serial control port that supports both SPI and I²C forms of communication. The mode of communication is determined by the states of the \overline{RD} (pin 5) and \overline{WR} (pin 4) pins at the rising edge of \overline{RESET} (pin 36). Table 1 below shows the two possible mode configurations:

Other modes are not supported at this time and should not be used. If the mode pins are driven dynamically by the host, then set up (t_{rstsu}) and hold

RD	WR	MODE
0	1	I ² C
1	0	SPI

Table 1. Serial Host Mode Configurations

(t_{rsthd}) times must be satisfied around the rising edge of reset as specified in the \overline{RESET} Switching characteristics portion of the CS492X Family Datasheet.

The following sections will explain each communication mode in more detail. Flow diagrams will illustrate read and write cycles. Pseudocode is presented in “Appendix A - Pseudocode For The CS4923/4/5/6/7/8/9 Family” 58 to demonstrate communication with the chip from a programming perspective.

Timing diagrams will be shown to demonstrate relative edge positions of signal transitions for read and write operations.

Only the subsection describing the communication mode being used needs to be read by the system designer.

2.1.1 SPI Communication

SPI communication with the CS4923/4/5/6/7/8/9 is accomplished with 5 communication lines: chip select, serial control clock, serial data in, serial data out and an interrupt request line to signal that the DSP has data to transmit to the host. Table 2 shows the mnemonic, pin name and pin number of each of these signals on the CS4923/4/5/6/7/8/9.

Mnemonic	Pin Name	Pin Number
Chip Select	CS	18
Serial Clock	SCCLK	7
Serial Data In	SCDIN	6
Serial Data Out	SCDOUT	19
Interrupt Request	INTREQ	20

Table 2. SPI Communication Signals

2.1.1.1 Writing in SPI

When writing to the device in SPI the same protocol will be used whether writing a byte, a message or even an entire executable download image. The examples shown in this document can be expanded to fit any write situation. Figure 1 shows a typical write sequence:

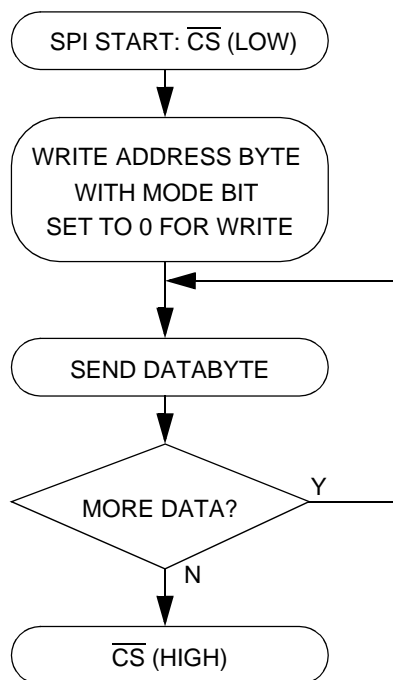

Figure 1. SPI Write Flow Diagram

The following is a detailed description of an SPI write sequence with the CS492X.

- 1) An SPI transfer is initiated when chip select (\overline{CS}) is driven low.
- 2) This is followed by a 7-bit address and the read/write bit set low for a write. The address for the CS492X defaults to 0000000b. It is necessary to clock this address in prior to any transfer in order for the CS492X to accept the write. In other words a byte of 0x00 should be clocked into the device preceding any write. The 0x00 byte represents the 7 bit address 0000000b, and the least significant bit set to 0 to designate a write.

- 3) The host should then clock data into the device most significant bit first, one byte at a time. The data byte is transferred to the DSP on the falling edge of the eighth serial clock. For this reason, the serial clock should be default low so that eight transitions from low to high to low will occur for each byte.
- 4) When all of the bytes have been transferred, chip select should be raised to signify an end of write. Once again it is crucial that the serial clock transitions from high to low on the last bit of the last byte before chip select is raised, or a loss of data will occur.

The pseudocode in Section 6.1.1 “SPI Write Operation” -- page 58 demonstrates a write operation for the SPI mode of communication.

The same write routine could be used to send a single byte, message or an entire application code image. From a hardware perspective, it makes no difference whether communication is by byte or multiple bytes of any length as long as the correct hardware protocol is followed.

2.1.1.2 Reading in SPI

A read operation is necessary when the CS4923/4/5/6/7/8/9 signals that it has data to be read. The CS492X does this by dropping its interrupt request line (\overline{INTREQ}) low. When reading from the device in SPI, the same protocol will be used whether reading a single byte or multiple bytes. The examples shown in this document can be expanded to fit any read situation. Figure 2 shows a typical read sequence:

The following is a detailed description of an SPI read sequence with the CS492X.

- 1) An SPI read transaction is initiated by the CS492X dropping \overline{INTREQ} , signaling that it has data to be read.
- 2) The host responds by driving chip select (\overline{CS}) low.

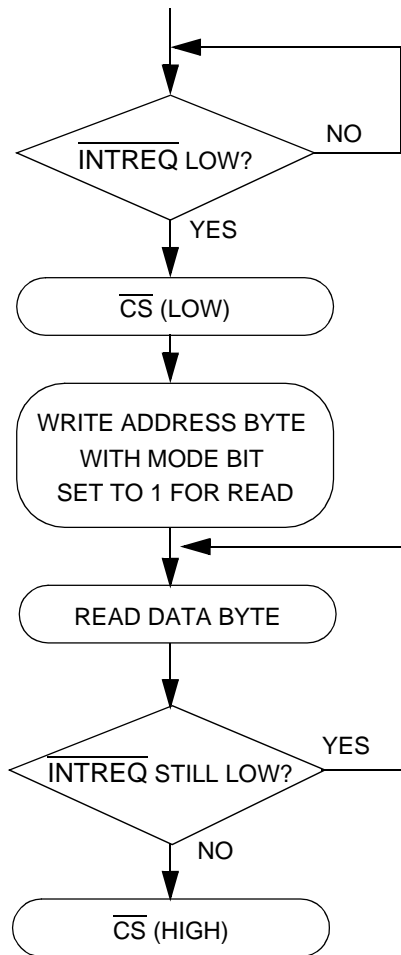

Figure 2. SPI Read Flow Diagram

- 3) This is followed by a 7-bit address and the read/write bit set high for a read. The address for the CS492X defaults to 0000000b. It is necessary to clock this address in prior to any transfer in order for the CS492X to acknowledge the read. In other words a byte of 0x01 should be clocked into the device preceding any read. The 0x01 byte represents the 7 bit address 0000000b, and the least significant bit set to 1 to designate a read.
- 4) After the falling edge of the serial control clock (SCCLK) for the read/write bit, the data is ready to be clocked out on the control data out pin (CDOOUT). Data clocked out by the host is valid on the rising edge of SCCLK and data

transitions occur on the falling edge of SCCLK. The serial clock should be default low so that eight transitions from low to high to low will occur for each byte.

- 5) If $\overline{\text{INTREQ}}$ is still low, another byte should be clocked out of the CS492X. Please see the discussion below for a complete description of $\overline{\text{INTREQ}}$ behavior.
- 6) When $\overline{\text{INTREQ}}$ has risen, the chip select line of the CS492X should be raised to end the read transaction.

Understanding the role of $\overline{\text{INTREQ}}$ is important for successful communication. $\overline{\text{INTREQ}}$ is guaranteed to remain low (once it has gone low) until the second to last rising edge of SCCLK of the last byte to be transferred out of the CS492X. If there is no more data to be transferred, $\overline{\text{INTREQ}}$ will go high at this point. For SPI this is the rising edge for the second to last bit of the last byte to be transferred. After going high, $\overline{\text{INTREQ}}$ is guaranteed to stay high until the next rising edge of SCCLK. This end of transfer condition signals the host to end the read transaction by clocking the last data bit out and raising $\overline{\text{CS}}$. If $\overline{\text{INTREQ}}$ is still low after the second to last rising edge of SCCLK, the host should continue reading data from the serial control port.

It should be noted that all data should be read out of the serial control port during one cycle or a loss of data will occur. In other words, all data should be read out of the chip until $\overline{\text{INTREQ}}$ signals the last byte by going high as described above. Please see Section 2.1.3 “ $\overline{\text{INTREQ}}$ Behavior: A Special Case” -- page 10 for a more detailed description of $\overline{\text{INTREQ}}$ behavior.

The pseudocode in Section 6.1.2 “SPI Read Operation” -- page 59 demonstrates a read operation for the SPI mode of communication.

The Figure 3 timing diagram shows the relative edges of the control lines for an SPI read and write.

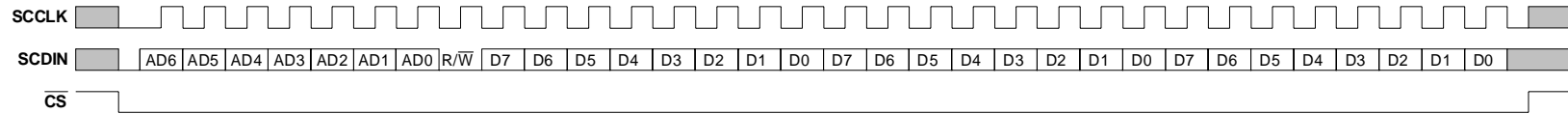

SPI Write Functional Timing

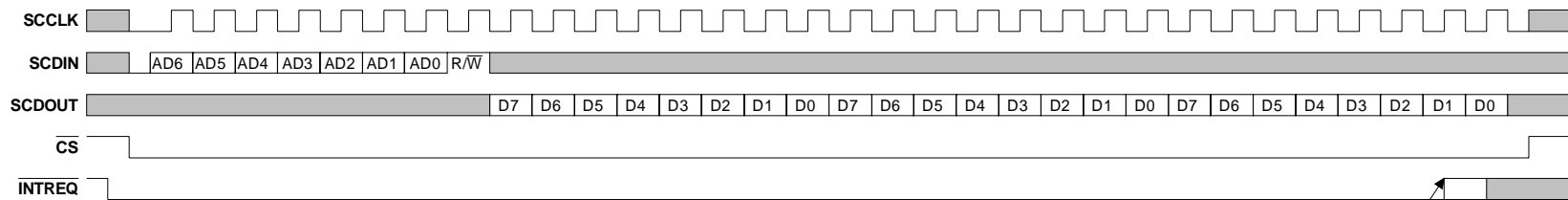

SPI Read Functional Timing

Note 1 Note 2

- Notes:
1. $\overline{\text{INTREQ}}$ is guaranteed to stay LOW until the rising edge of SCCLK for bit D1 of the last byte to be transferred out of the CS4923/4/5/6/7/8/9.
 2. $\overline{\text{INTREQ}}$ is guaranteed to remain HIGH until the next rising edge of SCCLK at which point it may go LOW again if there is new data to be read. The condition of INTREQ going LOW at this point should be treated as a new read condition. After a stop condition, a new start condition and an address byte should be sent

Figure 3. SPI Timing

2.1.2 I²C Communication

I²C communication with the CS4923/4/5/6/7/8/9 is accomplished with 3 communication lines: serial control clock, a bi-directional serial data input/output line and an interrupt request line to signal that the DSP has data to transmit to the host. Table 3 shows the mnemonic, pin name and pin number of each of these signals on the CS492X.

Mnemonic	Pin Name	Pin Number
Serial Clock	SCCLK	7
Bi-Directional Data	SCDIO	19
Interrupt Request	INTREQ	20

Table 3. I²C Communication Signals

Typically in I²C communication SCDIO is an open drain line with a pull-up. A logic one is placed on the line by tri-stating the output and allowing the pull-up to raise the line. At this point another device can drive the line low if necessary. Tri-stating SCDIO can have two effects: 1. To send out a one when writing data or sending a “no acknowledge”; 2. release the line when another chip is writing data.

For our pseudocode examples, driving SCDIO high effectively tri-states this signal since it is open drain and SCDIO (HIGH) should be interpreted as such.

2.1.2.1 Writing in I²C

When writing to the device in I²C the same protocol will be used whether writing a byte, a message or even an application code image. The examples shown in this document can be expanded to fit any write situation. Figure 4 shows a typical write sequence:

The following is a detailed description of an I²C write sequence with the CS492X.

- 1) An I²C transfer is initiated with an I²C start condition which is defined as the data (SCDIO) line falling while the clock (SCCLK) is held high.

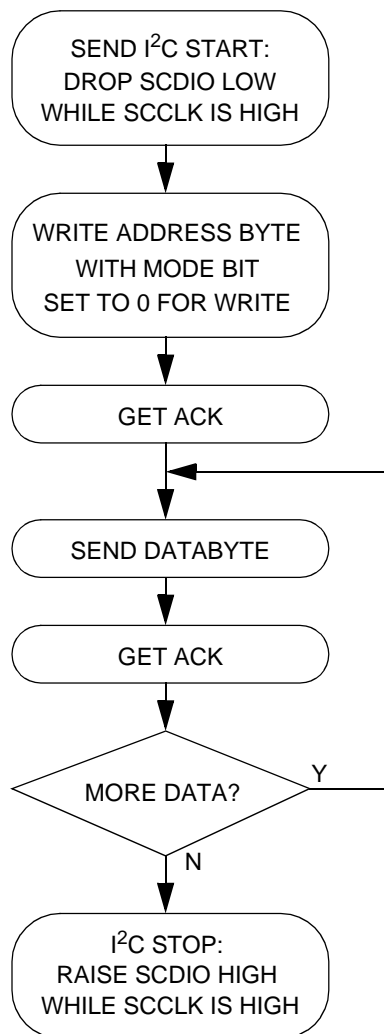

Figure 4. I²C Write Flow Diagram

- 2) Next a 7-bit address with the read/write bit set low for a write should be sent to the CS492X. The address for the CS492X defaults to 0000000b. It is necessary to clock this address in prior to any transfer in order for the CS492X to accept the write. In other words a byte of 0x00 should be clocked into the device preceding any write. The 0x00 byte represents the 7 bit of address (0000000b) and the read/write bit set to 0 to designate a write.

- 3) After each byte (including the address and each data byte) the host must release the data line and provide a ninth clock for the CS492X to acknowledge. The CS492X will drive the data line low during the ninth clock to acknowledge. If for some reason the CS492X does not acknowledge, it means that the last byte sent was not received and should be resent. If the resent byte fails to produce an acknowledge, a stop condition should be sent and the device should be reset.
- 4) The host should then clock data into the device most significant bit first, one byte at a time. The CS492X will (and must) acknowledge each byte that it receives which means that after each byte the host must provide an acknowledge clock pulse on SCCLK and release the data line, SCDDIO.
- 5) At the end of a data transfer a stop condition must be sent. The stop condition is defined as the rising edge of SCDDIO while SCCLK is high.

The pseudocode in Section 6.2.1 “I²C Write Operation” -- page 60 demonstrates a write operation for the I²C mode of communication.

2.1.2.2 Reading in I²C

A read operation is necessary when the CS4923/4/5/6/7/8/9 signals that it has data to be read. It does this by dropping its interrupt request line (INTREQ) low. When reading from the device in I²C, the same protocol will be used whether reading a single byte or multiple bytes. The examples shown in this document can be expanded to fit any read situation. Figure 5 shows a typical I²C read sequence

- 1) An I²C read transaction is initiated by the CS492X dropping $\overline{\text{INTREQ}}$, signaling that it has data to be read.

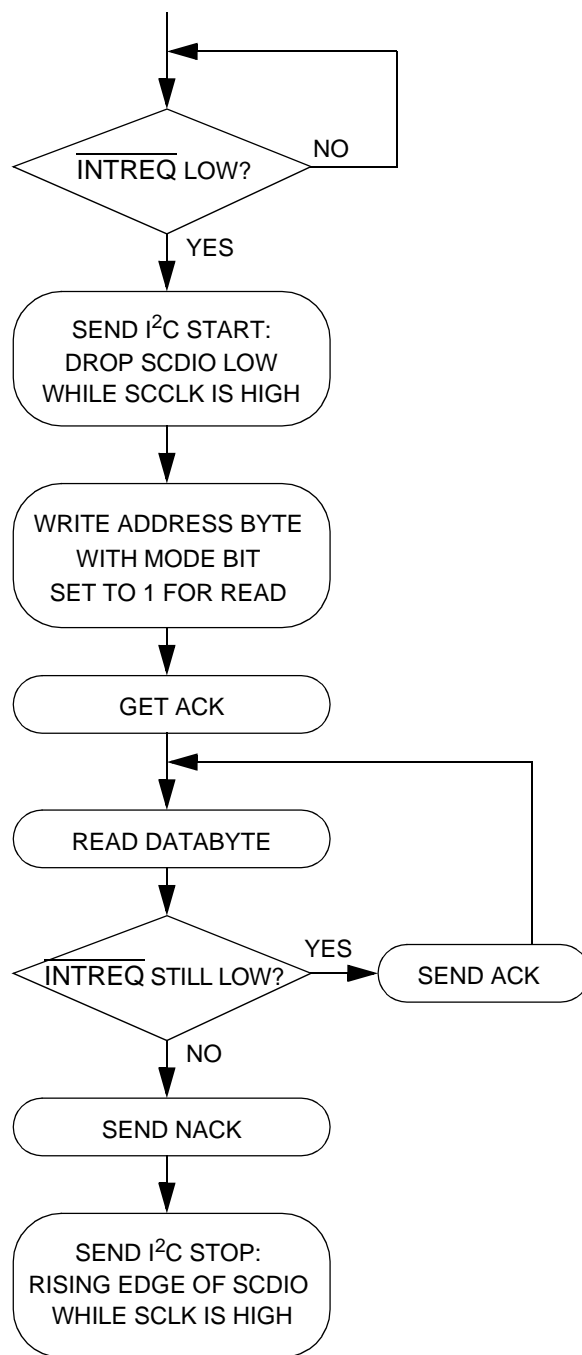

Figure 5. I²C Read Flow Diagram

- 2) The host responds by sending an I²C start condition which is SCDDIO dropping while SCCLK is held high.

- 3) The start condition is followed by a 7-bit address and the read/write bit set high for a read. The address for the CS492X defaults to 0000000b. It is necessary to clock this address in prior to any transfer in order for the CS492X to acknowledge the read. In other words a byte of 0x01 should be clocked into the device preceding any read. The 0x01 byte represents the 7 bit address 0000000b and a read/write bit set to 1 to designate a read.
- 4) After the falling edge of the serial control clock (SCCLK) for the read/write bit of the address byte, an acknowledge must be read in by the host. The CS492X will drive SCGIO low to acknowledge the address byte and to indicate that it is ready for a read operation. If an acknowledge is not sent by the CS492X, a stop condition should be issued and the read sequence should be restarted.
- 5) The data is ready to be clocked out on the SCGIO line at this point. Data clocked out by the host is valid on the rising edge of SCCLK and data transitions occur on the falling edge of SCCLK.
- 6) If $\overline{\text{INTREQ}}$ is still low after a byte transfer, an acknowledge (SCGIO clocked low by SCCLK) must be sent by the host to the CS492X and another byte should be clocked out of the CS492X. Please see the discussion below for a complete description of $\overline{\text{INTREQ}}$'s behavior.
- 7) When $\overline{\text{INTREQ}}$ has risen, a no acknowledge should be sent by the host (SCGIO clocked high by the host) to the CS492X. This, followed by an I²C stop condition (SCGIO raised, while SCCLK is high) signals an end of read to the CS492X.

Understanding the role of $\overline{\text{INTREQ}}$ is important for successful communication. $\overline{\text{INTREQ}}$ is guaranteed to remain low (once it has gone low), until the rising edge of SCCLK for the last bit of the last byte to be transferred out of the CS492X (i.e. the rising

edge of SCCLK before the ACK SCCLK). If there is no more data to be transferred, $\overline{\text{INTREQ}}$ will go high at this point. After going high, $\overline{\text{INTREQ}}$ is guaranteed to stay high until the next rising edge of SCCLK (i.e. it will stay high until the rising edge of SCCLK for the ACK/NACK bit). This end of transfer condition signals the host to end the read transaction by clocking the last data bit out of the CS492X and then sending a no acknowledge to the CS492X to signal that the read sequence is over. At this point the host should send an I²C stop condition to complete the read sequence. If $\overline{\text{INTREQ}}$ is still low after the rising edge of SCCLK on the last data bit of the current byte, the host should send an acknowledge and continue reading data from the serial control port.

It should be noted that all data should be read out of the serial control port during one cycle or a loss of data will occur. In other words, all data should be read out of the chip until $\overline{\text{INTREQ}}$ signals the last byte by going high as described above. Please see Section 2.1.3 “ $\overline{\text{INTREQ}}$ Behavior: A Special Case” -- page 10 for a more detailed description of $\overline{\text{INTREQ}}$ behavior.

The pseudocode in Section 6.2.2 “I²C Read Operation” -- page 62 demonstrates a read operation for the I²C mode of communication.

The timing diagram in Figure 6 shows the relative edges of the control lines for an I²C read and write.

2.1.3 $\overline{\text{INTREQ}}$ Behavior: A Special Case

When communicating with the CS4923/4/5/6/7/8/9 there are two types of messages which force $\overline{\text{INTREQ}}$ to go low. These messages are known as solicited messages and unsolicited messages. For more information on the specific types of messages that require a read from the host, one of the application code user's guides should be referenced.

In general, when communicating with the CS492X, $\overline{\text{INTREQ}}$ will not go low unless the host first sends

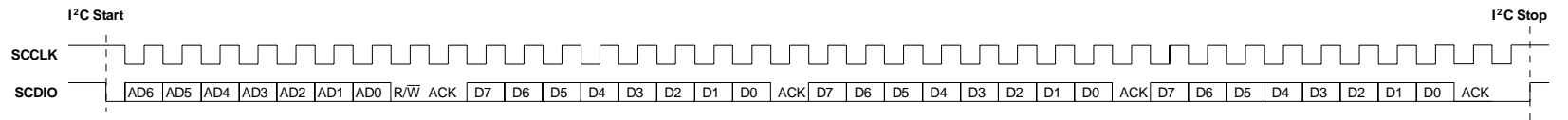
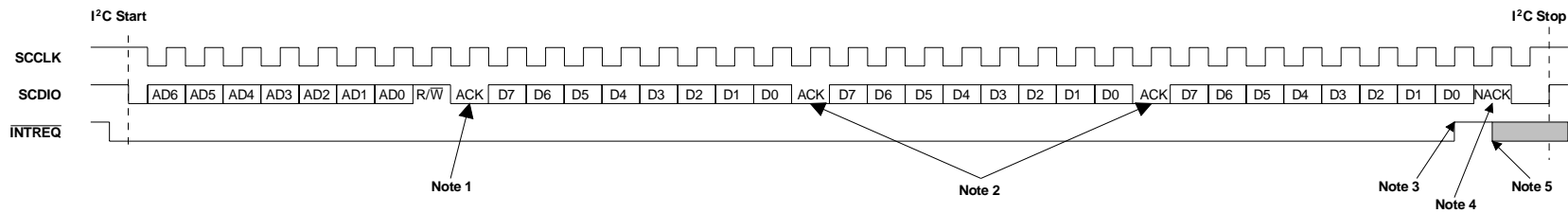
I²C Write Functional TimingI²C Read Functional Timing

- Notes:
1. The ACK for the address byte is driven by the CS4923/4/5/6/7/8/9.
 2. The ACKs for the data bytes being read from the CS4923/4/5/6/7/8/9 should be driven by the host.
 3. $\overline{\text{INTREQ}}$ is guaranteed to stay LOW until the rising edge of SCCLK for bit D0 of the last byte to be transferred out of the CS4923/4/5/6/7/8/9.
 4. A NACK should be sent by the host after the last byte to indicate the end of the read cycle.
 5. $\overline{\text{INTREQ}}$ is guaranteed to stay HIGH until the next rising edge of SCCLK (for the ACK/NACK bit) at which point it may go LOW again if there is new data to be read. The condition of $\overline{\text{INTREQ}}$ going LOW at this point should be treated as a new read condition. After a stop condition, a new start condition followed by an address byte should be sent.

Figure 6. I²C Timing

a read request command message. In other words the host must solicit a response from the DSP. In this environment, the host must read from the CS492X until $\overline{\text{INTREQ}}$ goes high again. Once the $\overline{\text{INTREQ}}$ pin has gone high it will not be driven low until the host sends another read request.

When unsolicited messages, such as those used for Autodetect, have been enabled, the behavior of $\overline{\text{INTREQ}}$ is noticeably different. The CS492X will drop the $\overline{\text{INTREQ}}$ pin whenever the DSP has an outgoing message, even though the host may not have requested data.

There are three ways in which $\overline{\text{INTREQ}}$ can be affected by an unsolicited message:

- 1) During normal operation, while $\overline{\text{INTREQ}}$ is high, the DSP could drop $\overline{\text{INTREQ}}$ to indicate an outgoing message, without a prior read request.
- 2) The host is in the process of reading from the CS492X, meaning that $\overline{\text{INTREQ}}$ is already low. An unsolicited message arrives which forces $\overline{\text{INTREQ}}$ to remain low after the solicited message is read.
- 3) The host is reading from the CS492X when the unsolicited message is queued, but $\overline{\text{INTREQ}}$ goes high for one period of SCCLK and then goes low again before the end of the read cycle.

In case (1) the host should perform a read operation as discussed in the previous sections.

In case (2) an unsolicited message arrives before the second to last SCCLK of the final byte transfer of a read, forcing the $\overline{\text{INTREQ}}$ pin to remain low. In this scenario the host should continue to read from the CS492X without a stop/start condition or data will be lost.

In case (3) an unsolicited message arrives between the second to last SCCLK and the last SCCLK of the final byte transfer of a read. In this scenario, $\overline{\text{INTREQ}}$ will transition high for one clock (as if the read transaction has ended), and then back low (indicating that more data has queued). This final

case is the most complicated and shall be explained in detail.

There are two constraints which completely characterize the behavior of the $\overline{\text{INTREQ}}$ pin during a read. The first constraint is that the $\overline{\text{INTREQ}}$ pin is guaranteed to remain low until the second to last SCCLK (SCCLK number N-1) of the final byte being transferred from the CS492X (not necessarily the second to last bit of the data byte). The second constraint is that once the $\overline{\text{INTREQ}}$ pin has gone high it is guaranteed to remain high until the rising edge of the last SCCLK (SCCLK number N) of the final byte being transferred from the CS492X (not necessarily the last bit of the data byte). If an unsolicited message arrives in the window of time between the rising edge of the second to last SCCLK and the final SCCLK, $\overline{\text{INTREQ}}$ will drop low on the rising edge of the final SCCLK as illustrated in the functional timing diagrams shown for I²C and SPI read cycles.

$\overline{\text{INTREQ}}$ behavior for I²C communication is illustrated in figure 6. When using I²C communication the $\overline{\text{INTREQ}}$ pin will remain low until the rising edge of SCCLK for the data bit D0 (SCCLK N-1), but it can go low at the rising edge of SCCLK for the NACK bit (SCCLK N) if an unsolicited message has arrived. If no unsolicited messages arrive, the $\overline{\text{INTREQ}}$ pin will remain high after rising.

$\overline{\text{INTREQ}}$ behavior for SPI communication is illustrated in figure 3. When using SPI communication, the $\overline{\text{INTREQ}}$ pin will remain low until the rising edge of SCCLK for the data bit D1 (SCCLK N-1), but it can go low at the rising edge of SCCLK for data bit D0 (SCCLK N) if an unsolicited message has arrived. If no unsolicited messages arrive, the $\overline{\text{INTREQ}}$ pin will remain high after rising.

Ideally, the host will sample $\overline{\text{INTREQ}}$ on the falling edge of SCCLK number N-1 of the final byte of each read response message. If $\overline{\text{INTREQ}}$ is

sampled high, the host should conclude the current read cycle using the stop condition defined for the communication mode chosen. The host should then begin a new read cycle complete with the appropriate start condition and the chip address. If $\overline{\text{INTREQ}}$ is sampled low, the host should continue reading the next message from the CS492X without ending the current read cycle.

When using automated communication ports, however, the host is often limited to sampling the status of $\overline{\text{INTREQ}}$ after an entire byte has been transferred. In this situation a low-high-low transition (case 3) would be missed and the host will see a constantly low $\overline{\text{INTREQ}}$ pin. Since the host should read from the CS492X until it detects that $\overline{\text{INTREQ}}$ has gone high, this condition will be treated as a multiple-message read (more than one read response is provided by the CS492X). Under these conditions a single byte of 0x00 will be read out before the unsolicited message.

The length of every read response is defined in the user's manual for each piece of application code. Thus, the host should know how many bytes to expect based on the first byte (the OPCODE) of a read response message. It is guaranteed that no read responses will begin with 0x00, which means that a NULL byte (0x00) detected in the OPCODE position of a read response message should be discarded. Please see an Application Code User's Guide for an explanation of the OPCODE.

It is important that the host be aware of the presence of NULL bytes, or the communication channel could become corrupted.

When case (3) occurs and the host issues a stop condition before starting a new read cycle, the first byte of the unsolicited message is loaded directly into the shift register and 0x00 is never seen.

Alternatively, if case (3) occurs and the host continues to read from the CS492X without a stop condition (a multiple message read), the 0x00 byte

must be shifted out of the CS492X before the first byte of the unsolicited message can be read.

In other words, if a system can only sample $\overline{\text{INTREQ}}$ after an entire byte transfer the following routine should be used if $\overline{\text{INTREQ}}$ is low after the last byte of the message being read:

- 1) Read one byte
- 2) If the byte == 0x00 discard it and skip to step 3. If the byte != 0x00 then it is the OPCODE for the next message. For this case skip to step 4.
- 3) Read one more byte. This is the OPCODE for the next message.
- 4) Read the rest of the message as indicated in the previous sections.

2.2 Parallel Host Communication

The parallel host communication modes of the CS4923/4/5/6/7/8/9 provide an 8-bit interface to the DSP. An Intel-style parallel mode and a Motorola-style parallel mode are supported. The mode of communication is determined by the states of the $\overline{\text{RD}}$ (pin 5), $\overline{\text{WR}}$ (pin 4), and PSEL (pin 19) pins at the rising edge of $\overline{\text{RESET}}$ (pin 36). Each time the CS492X is reset, the $\overline{\text{RD}}$, $\overline{\text{WR}}$, and PSEL pins are sampled to determine how the host interface port will be configured. Table 4 shows the necessary pin configurations for selecting a parallel configuration mode.

RD	WR	PSEL	MODE
1	1	0	Intel Mode
1	1	1	Motorola Mode

Table 4. Parallel Host Mode Configurations

The host interface is implemented using four communication registers within the CS492X:

- The Host Message register (A[1:0]==00b): receives incoming control data bytes and provides outgoing response data bytes.

- The Host Control register (A[1:0]=01b): provides information about the state of the communication interface.
- The PCM Data Input register (A[1:0]=10b): accepts bytes of linear PCM audio data (WRITE ONLY).
- The Compressed Data Input register (A[1:0]=11b): accepts bytes of compressed audio data (WRITE ONLY).

When the host is downloading code to the CS492X or configuring the application code, control messages will be written to (and read from) the Host Message register. The Host Control register is used during messaging sessions to determine when the CS492X can accept another byte of control data, and when the CS492X has an outgoing byte that may be read.

The PCM Data and Compressed Data registers are used strictly for the transfer of audio data. The host cannot read from these two registers. Audio data written to registers 11b and 10b are transferred directly to the internal FIFOs of the CS492X. When the level of the PCM FIFO reaches the FIFO threshold level, the MFC bit of the Host Control register will be set. When the level of the Compressed Data FIFO reaches the FIFO threshold level, the MFB bit of the Host Control register will be set.

It is important to remember that the parallel host interface requires the DATA[7:0] pins of the CS492X. The external memory interface also requires the DATA[7:0] pins. This conflict results in the following constraint:

- Parallel host communication modes cannot be used when processing DTS (CS4926 and CS4928)

Systems that require DTS capability and systems utilizing the autoboot capabilities of the CS492X must use a serial host communication protocol.

A detailed description for each parallel host mode will now be given. The following information will be provided for the Intel mode and Motorola mode:

- The pins of the CS492X which must be used for proper communication
- Flow diagram and description for a parallel byte write
- Flow diagram and description for a parallel byte read

The four registers of the CS492X's parallel host mode are not used identically. The algorithm used for communicating with each register will be given as a functional description, building upon the basic read and write protocols defined in the Motorola and Intel sections. The following will be covered:

- Flow diagram and description for a control write
- Flow diagram and description for a control read

2.2.1 Intel Parallel Host Communication Mode

The Intel parallel host communication mode is implemented using the pins given in Table 5.

Mnemonic	Pin Name	Pin Number
Chip Select	\overline{CS}	18
Write Enable	\overline{WR}	4
Output Enable	\overline{RD}	5
Register Address Bit 1	A1	6
Register Address Bit 0	A0	7
Interrupt Request	\overline{INTREQ}	19
DATA7	DATA7	8
DATA6	DATA6	9
DATA5	DATA5	10
DATA4	DATA4	11
DATA3	DATA3	14
DATA2	DATA2	15
DATA1	DATA1	16
DATA0	DATA0	17

Table 5. Intel Mode Communication Signals

The \overline{INTREQ} pin is controlled by the application code when a parallel host communication mode has been selected. When the code supports \overline{INTREQ} notification, the \overline{INTREQ} pin is asserted whenever the DSP has an outgoing message for the host. This

same information is reflected by the HOUTRDY bit of the Host Control Register ($A[1:0] = 01b$).

\overline{INTREQ} is useful for informing the host of unsolicited messages. An unsolicited message is defined as a message generated by the DSP without an associated host read request. Unsolicited messages can be used to notify the host of conditions such as a change in the incoming audio data type (e.g. PCM --> AC-3).

2.2.1.1 Writing a Byte in Intel Mode

Information provided in this section is intended as a functional description of how to write control information to the CS492X. The system designer must insure that all of the timing constraints of the Intel Parallel Host Mode Write Cycle are met. The timing specifications for the Intel Parallel Host Mode can be found in the CS4923/4/5/6/7/8/9 Family Datasheet.

The flow diagram shown in Figure 7 illustrates the sequence of events that define a one-byte write in Intel mode.

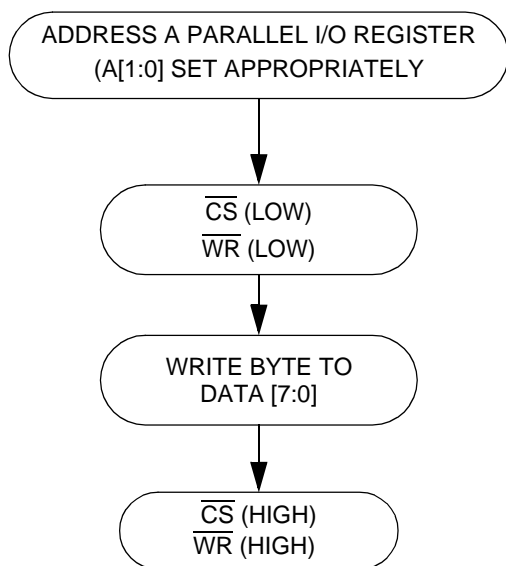

Figure 7. Intel Mode, One-Byte Write Flow Diagram

The protocol presented in Figure 7 will now be described in detail.

- 1) The host must first drive the A1 and A0 register address pins of the CS492X with the address of the desired Parallel I/O Register.

Host Message: $A[1:0] == 00b$.

Host Control: $A[1:0] == 01b$.

PCMDATA: $A[1:0] == 10b$.

CMPDATA: $A[1:0] == 11b$.

- 2) The host then indicates that the selected register will be written. The host initiates a write cycle by driving the \overline{CS} and \overline{WR} pins low.
- 3) The host drives the data byte to the DATA[7:0] pins of the CS492X.
- 4) Once the setup time for the write has been met, the host ends the write cycle by driving the \overline{CS} and \overline{WR} pins high.

2.2.1.2 Reading a Byte in Intel Mode

Information provided in this section is intended as a functional description of how to write control information to the CS492X. The system designer must insure that all of the timing constraints of the Intel Parallel Host Mode Read Cycle are met. The timing specifications for the Intel Parallel Host Mode can be found in the CS4923/4/5/6/7/8/9 Family Datasheet

The flow diagram shown in Figure 8 illustrates the sequence of events that define a one-byte read in Intel mode.

The protocol presented in Figure 8 will now be described in detail.

- 1) The host must first drive the A1 and A0 register address pins of the CS492X with the address of the desired Parallel I/O Register. Note that only the Host Message register and the Host Control register can be read.

Host Message: $A[1:0] == 00b$.

Host Control: $A[1:0] == 01b$.

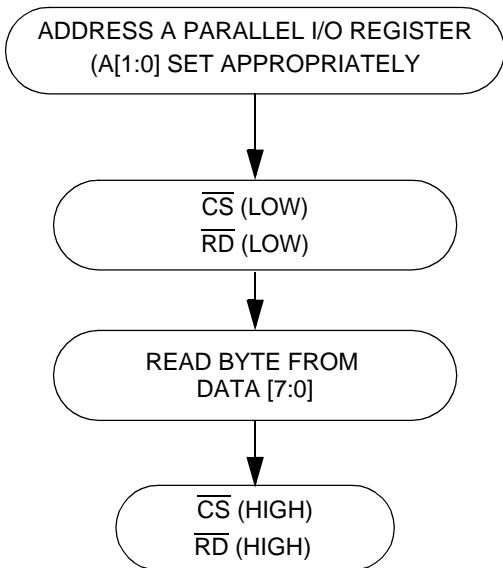

Figure 8. Intel Mode, One-Byte Read Flow Diagram

- 2) The host now indicates that the selected register will be read. The host initiates a read cycle by driving the \overline{CS} and \overline{RD} pins low.
- 3) Once the data is valid, the host can read the value of the selected register from the DATA[7:0] pins of the CS492X.
- 4) The host should now terminate the read cycle by driving the \overline{CS} and \overline{RD} pins high.

2.2.2 Motorola Parallel Host Communication Mode

The Motorola parallel host communication mode is implemented using the pins given in Table 6. The \overline{INTREQ} pin is controlled by the application code when a parallel host communication mode has been selected. When the code supports \overline{INTREQ} notification, the \overline{INTREQ} pin is asserted whenever the DSP has an outgoing message for the host. This same information is reflected by the HOUTRDY bit of the Host Control Register (A[1:0] = 01b).

\overline{INTREQ} is useful for informing the host of unsolicited messages. An unsolicited message is defined as a message generated by the DSP without an associated host read request. Unsolicited messages can be used to notify the host of conditions such as a change in the incoming audio data type (e.g. PCM --> AC-3).

Mnemonic	Pin Name	Pin Number
Chip Select	\overline{CS}	18
Data Strobe	\overline{DS}	4
Read or Write Select	$\overline{R/W}$	5
Register Address Bit 1	A1	6
Register Address Bit 0	A0	7
Interrupt Request	\overline{INTREQ}	19
DATA7	DATA7	8
DATA6	DATA6	9
DATA5	DATA5	10
DATA4	DATA4	11
DATA3	DATA3	14
DATA2	DATA2	15
DATA1	DATA1	16
DATA0	DATA0	17

Table 6. Motorola Mode Communication Signals

2.2.2.1 Writing a Byte in Motorola Mode

Information provided in this section is intended as a functional description of how to write control information to the CS492X. The system designer must insure that all of the timing constraints of the Motorola Parallel Host Mode Write Cycle are met. The timing specifications for the Motorola Parallel Host Mode can be found in the CS4923/4/5/6/7/8/9 Family Datasheet.

The flow diagram shown in Figure 9 illustrates the sequence of events that define a one-byte write in Motorola mode.

The protocol presented in figure 9 will now be described in detail.

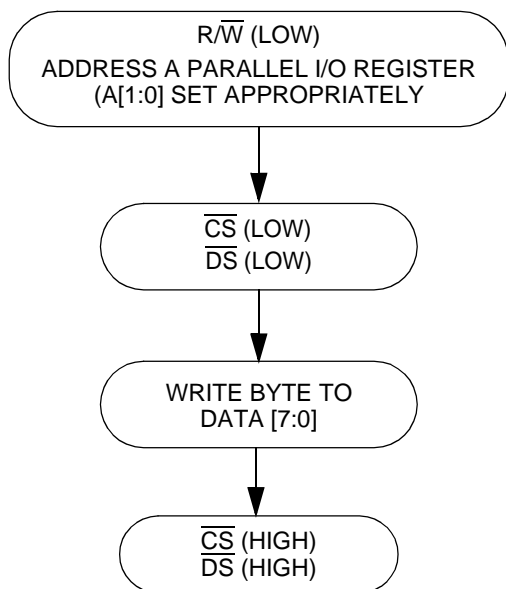

Figure 9. Motorola Mode, One-Byte Write Flow Diagram

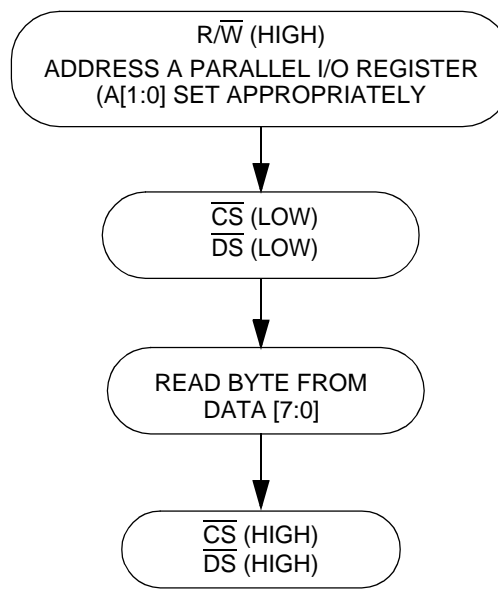

Figure 10. Motorola Mode, One-Byte Read Flow Diagram

- 1) The host must drive the A1 and A0 register address pins of the CS492X with the address of the desired Parallel I/O Register.

Host Message: A[1:0]==00b.

Host Control: A[1:0]==01b.

PCMDATA: A[1:0]==10b.

CMPDATA: A[1:0]==11b.

The host indicates that this is a write cycle by driving the $\overline{R/\overline{W}}$ pin low.

- 2) The host initiates a write cycle by driving the \overline{CS} and \overline{DS} pins low.
- 3) The host drives the data byte to the DATA[7:0] pins of the CS492X.
- 4) Once the setup time for the write has been met, the host ends the write cycle by driving the \overline{CS} and \overline{DS} pins high.

2.2.2.2 Reading a Byte in Motorola Mode

The flow diagram shown in Figure 10 illustrates the sequence of events that define a one-byte read in Motorola mode.

The protocol presented Figure 10 will now be described in detail.

- 1) The host must drive the A1 and A0 register address pins of the CS492X with the address of the desired Parallel I/O Register. Note that only the Host Message register and the Host Control register can be read.

Host Message: A[1:0]==00b.

Host Control: A[1:0]==01b.

The host indicates that this is a read cycle by driving the $\overline{R/\overline{W}}$ pin high.

- 2) The host initiates the read cycle by driving the \overline{CS} and \overline{DS} pins low.
- 3) Once the data is valid, the host can read the value of the selected register from the DATA[7:0] pins of the CS492X.
- 4) The host should now terminate the read cycle by driving the \overline{CS} and \overline{DS} pins high.

2.2.3 Procedures for Parallel Host Mode Communication

2.2.3.1 Control Write in a Parallel Host Mode

When writing control data to the CS492X, the same protocol is used whether the host is writing a control message or an entire executable download image. Messages sent to the CS492X should be written most significant byte first. Likewise, downloads of the application code should also be performed most significant byte first.

The example shown in this section can be generalized to fit any control write situation. The generic function ‘Read_Byte_*()’ is used in the following example as a generalized reference to either Read_Byte_MOT() or Read_Byte_INT(), and ‘Write_Byte_*()’ is a generic reference to Write_Byte_MOT() or Write_Byte_INT(). Figure 11 shows a typical write sequence.

The protocol presented in figure 11 will now be described in detail.

- 1) When the host is communicating with the CS492X, the host must verify that the DSP is ready to accept a new control byte. If the DSP is in the midst of an interrupt service routine, it will be unable to retrieve control data from the Host Message Register. Please note that ‘Read_Byte_*()’ and ‘Write_Byte_*()’ are generic references to either the Intel or Motorola communication protocol.

If the most recent control byte has not yet been read by the DSP, the host must not write a new byte.

- 2) In order to determine whether the CS492X is ready to accept a new control byte the host must check the HINBSY bit of the Host Control

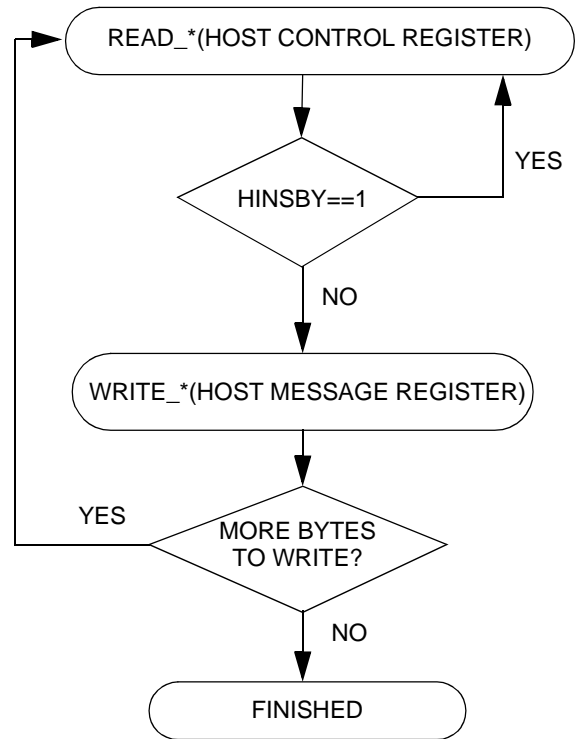

Figure 11. Typical Parallel Host Mode Control Write Sequence Flow Diagram

Register (bit 2). If HINBSY is high, then the DSP is not prepared to accept a new control byte, and the host should poll the Host Control Register again. If HINBSY is low, then the host may write a control byte into the Host Message Register.

- 3) The host knows that the DSP is ready for a new control byte at this point and should write the control byte to the Host Message Register (A[1:0] = 00b).
- 4) If the host would like to write any more control bytes to the CS492X, the host should once again poll the Host Control Register (return to step 1).

2.2.3.2 Control Read in a Parallel Host Mode

When reading control data from the CS4923/4/5/6/7/8/9, the same protocol is used whether the host is reading a single byte or a 6 byte message.

During the boot procedure, a handshaking protocol is used by the CS492X. This handshake consists of a 3 byte write to the CS492X followed by a 1 byte response from the DSP. The host must read the response byte and act accordingly. The boot procedure is discussed in Section 3.1 “Host Boot” - - page 25.

During regular operation (at run-time), the responses from the CS492X will always be 6 bytes in length.

The example shown in this section can be used for any control read situation. The generic function ‘Read_Byte_*()’ is used in the following example as a generalized reference to either Read_Byte_MOT() or Read_Byte_INT(). Figure 12 shows a typical read sequence.

The protocol presented in Figure 12 will now be described in detail.

- 1) Optionally, $\overline{\text{INTREQ}}$ going low may be used as an interrupt to the host to indicate that the CS492X has an outgoing message. Even with the use of $\overline{\text{INTREQ}}$, HOUTRDY must be checked to insure that bytes are ready for the host during the read process. Please note that $\overline{\text{INTREQ}}$ does not go low to indicate an outgoing message during boot.
- 2) The host reads the Host Control Register (A[1:0] = 01b) in order to determine the state of the communication interface. Please note that ‘Read_Byte_*()’ is a generalized reference to either Read_Byte_MOT() or Read_Byte_INT().

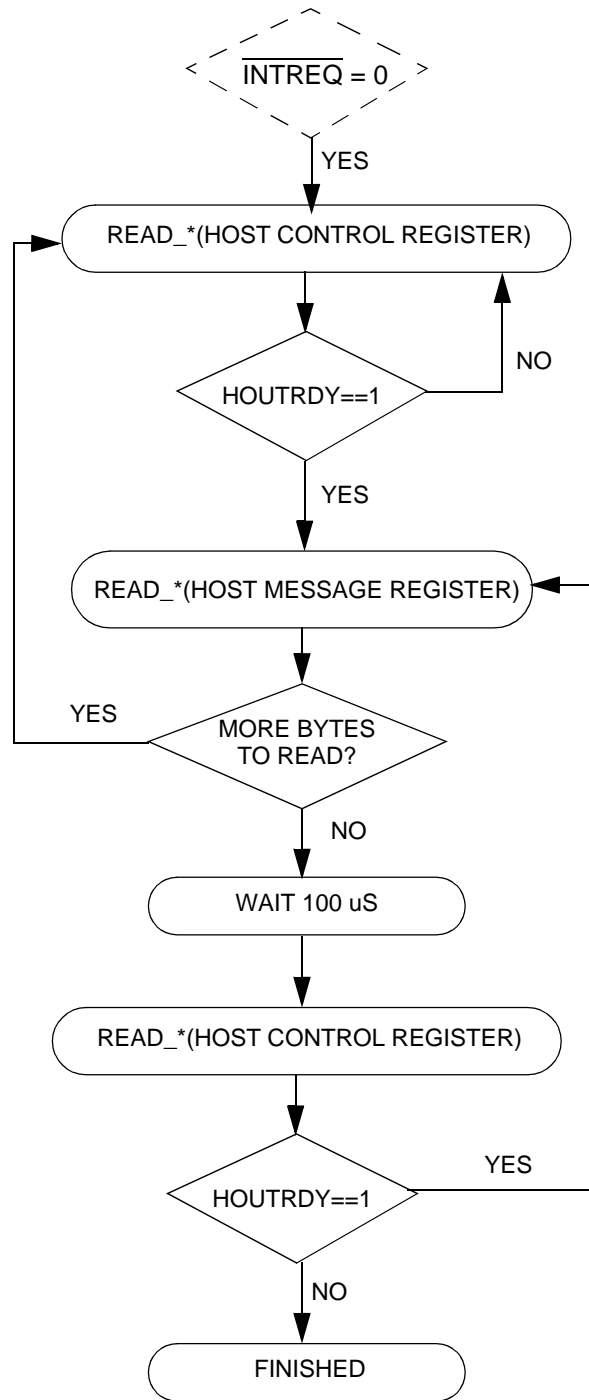

Figure 12. Typical Parallel Host Mode Control Read Sequence Flow Diagram

-
- 3) In order to determine whether the CS492X has an outgoing control byte that is valid, the host must check the HOUTRDY bit of the Host Control Register (bit 1). If HOUTRDY is high, then the Host Message Register contains a valid message byte for the host. If HOUTRDY is low, then the DSP has not placed a new control byte in the Host Message Register, and the host should poll the Host Control Register again.
 - 4) The host knows that the DSP is ready to provide a new response byte at this point. The host can safely read a byte from the Host Message Register ($A[1:0] = 00b$).
 - 5) If the host expects to read any more response bytes, the host should once again check the HOUTRDY bit (return to step 1). Please refer to one of the application code user's guides to determine the length of messages to read from the CS492X. Typically this length is 1, 3 or 6 bytes, and can be deduced from the message OPCODE.
 - 6) After the response has been read the host should wait at least 100 uS and check HOUTRDY one final time. If HOUTRDY is high once again this means that an unsolicited message has come during the read process and the host has another message to read (i.e. skip back to step 4 and read out the new message).

3. BOOT PROCEDURE & RESET

In this section the process of booting and downloading to the CS492X will be covered as well as how to perform a soft reset. Both host boot and autoboot are covered in this section.

3.1 Host Boot

A flow diagram of a typical serial download sequence and a typical parallel download sequence will be presented, as well as pseudocode representing a download sequence from the programmers perspective. The pseudocode is written in a general sense where function calls are made to Write_* and Read_*. The * can be replaced by I²C, SPI, INTEL, or MOTO depending on the mode of host communication. For each case the general download algorithm is the same.

The download and boot procedure is accomplished with $\overline{\text{RESET}}$ (pin 36), and the communication pins discussed in Section 2.1 “Serial Communication” - - page 8. The flow diagrams in Figures 13 and 14 illustrate a typical boot and download procedure. Table 7 defines the boot write messages and Table 8 defines the boot read messages in mnemonic and actual hex value. These messages will be used in the boot sequence.

The following is a detailed description of a download sequence for the CS492X. All writes and reads with the CS492X should follow the protocol given in Section 2 “Host Communication” -- page 8, and timing given in the CS492X Datasheet.

NOTE: When reading from the chip in a serial communication mode, the host must wait for the interrupt request ($\overline{\text{INTREQ}}$) to fall before starting the read cycle.

1) A download sequence is started when the host issues a hard reset and holds the mode pins appropriately ($\overline{\text{WR}}$, $\overline{\text{RD}}$, and PSEL) as described in Section 2 “Host Communication” -- page 8 and in the CS492X Datasheet. It is assumed that timing is satisfied as per the CS492X Datasheet.

- 2) The host should then send the boot message DOWNLOAD_BOOT (0x000004). This causes the CS492X to initialize itself for download.
- 3) If the initialization was successful the CS492X sends out the boot message BOOT_START (0x01) and the host should proceed to step 5.

MNEMONIC	VALUE
SOFT_RESET	0x000001
RESERVED	0x000002
RESERVED	0x000003
DOWNLOAD_BOOT	0x000004
BOOT_SUCCESS_RECEIVED	0x000005

Table 7. Boot Write Messages

MNEMONIC	VALUE
BOOT_START	0x01
BOOT_SUCCESS	0x02
APPLICATION_FAILURE	0xF0
BOOT_ERROR	0xFA
INVALID_MSG	0xFB
BOOT_ERROR	0xFC
INIT_FAILURE	0xFD
INIT_FAILURE	0xFE
BAD_CHECKSUM	0xFF

Table 8. Boot Read Messages

- 4) If initialization fails, the CS492X sends out an INIT_FAILURE boot message byte (0xFD or 0xFE), INVALID_MSG byte (0xFB), or BOOT_ERROR byte (0xFA or 0xFC) and spins waiting for a hard reset. The host should re-try steps 1 through 3 and if failure is met again, the serial communication timing and protocol should be inspected.
- 5) After receiving the BOOT_START byte, the host should write the downloadable image (from the .LD file).
- 6) The end of the .LD file contains a three byte checksum. If the checksum is good after download, the CS492X will send a BOOT_SUCCESS message (0x02) to the host.

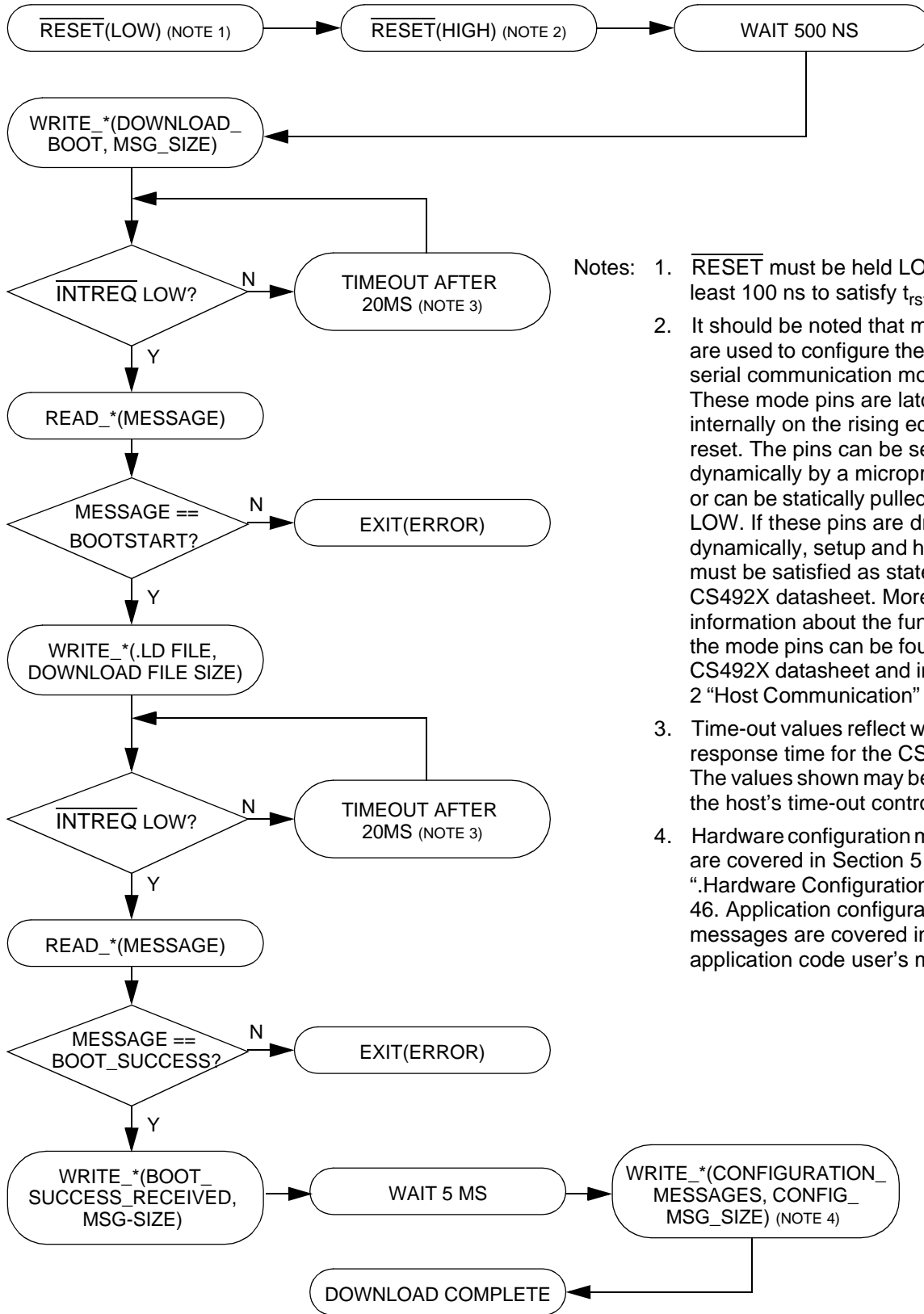

- Notes:
1. $\overline{\text{RESET}}$ must be held LOW for at least 100 ns to satisfy t_{rstl}
 2. It should be noted that mode pins are used to configure the CS492X serial communication mode. These mode pins are latched internally on the rising edge of reset. The pins can be set dynamically by a microprocessor or can be statically pulled HIGH or LOW. If these pins are driven dynamically, setup and hold times must be satisfied as stated in the CS492X datasheet. More information about the function of the mode pins can be found in the CS492X datasheet and in Section 2 "Host Communication" -- page 8.
 3. Time-out values reflect worst case response time for the CS492X. The values shown may be used for the host's time-out control loop.
 4. Hardware configuration messages are covered in Section 5 ".Hardware Configuration" -- page 46. Application configuration messages are covered in each application code user's manual.

Figure 13. Typical Serial Boot and Download Procedure

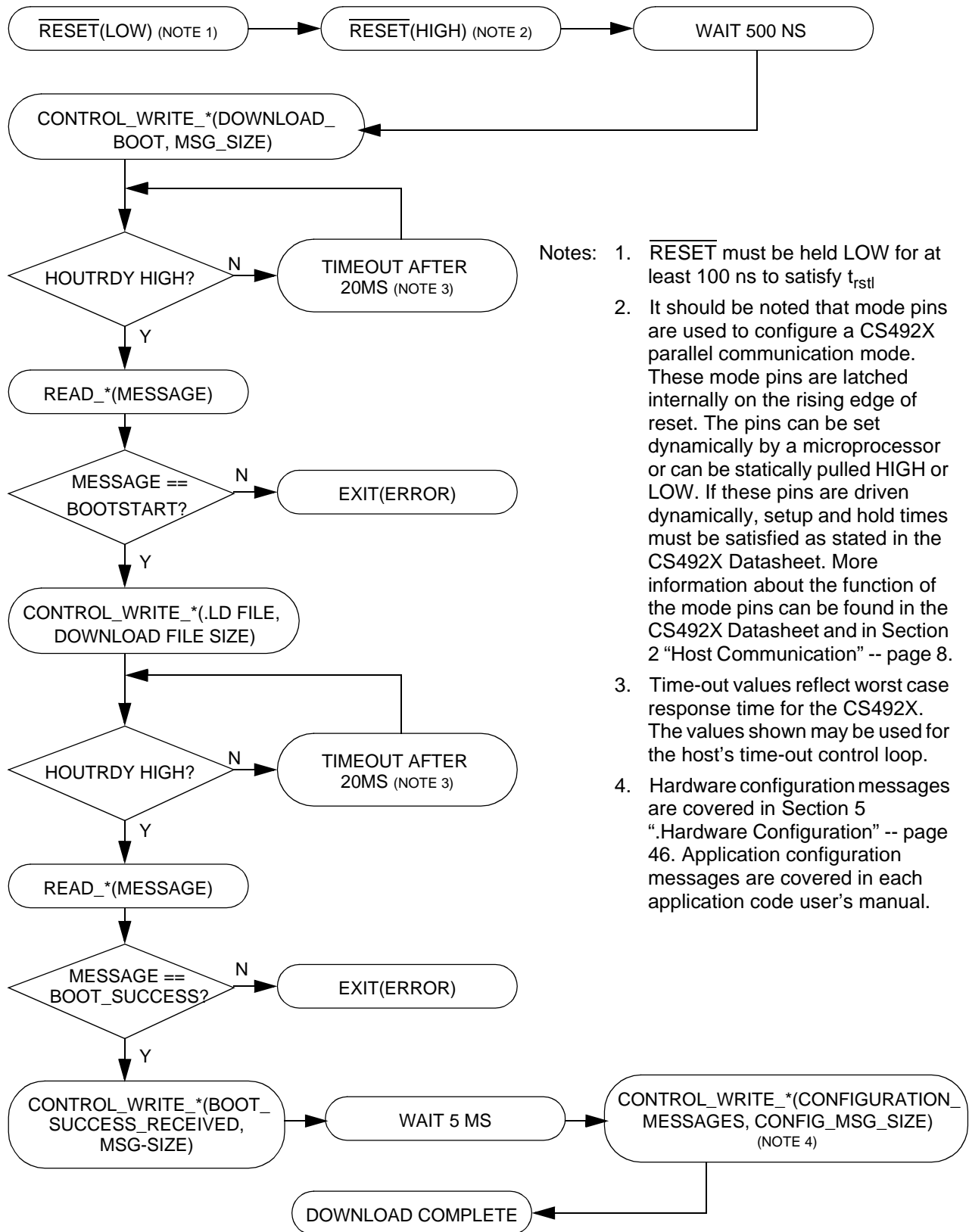

- Notes:
1. $\overline{\text{RESET}}$ must be held LOW for at least 100 ns to satisfy t_{rstl}
 2. It should be noted that mode pins are used to configure a CS492X parallel communication mode. These mode pins are latched internally on the rising edge of reset. The pins can be set dynamically by a microprocessor or can be statically pulled HIGH or LOW. If these pins are driven dynamically, setup and hold times must be satisfied as stated in the CS492X Datasheet. More information about the function of the mode pins can be found in the CS492X Datasheet and in Section 2 "Host Communication" -- page 8.
 3. Time-out values reflect worst case response time for the CS492X. The values shown may be used for the host's time-out control loop.
 4. Hardware configuration messages are covered in Section 5 ".Hardware Configuration" -- page 46. Application configuration messages are covered in each application code user's manual.

Figure 14. Typical Parallel Boot and Download Procedure

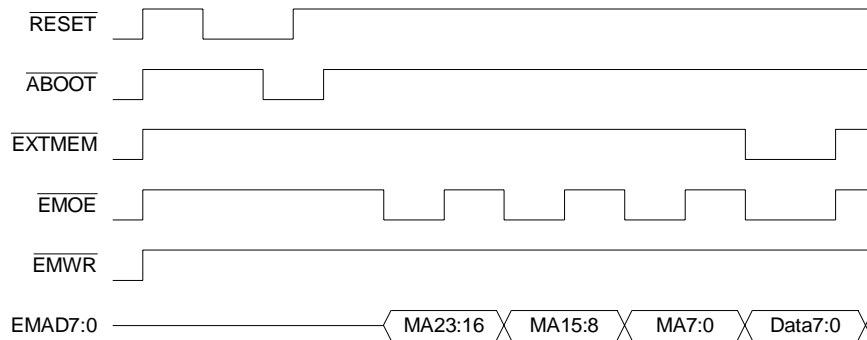

Figure 16. Autoboot Timing Diagram

both the input of the first latch, and the output of the ROM. The two latches are cascaded such that on each clock pulse a new address byte is latched into the first latch, and the previous ADDR[7:0] byte is latched into the second register becoming ADDR[15:8].

The timing for an autoboot sequence is illustrated in Figure 16. The sequence is initiated by driving $\overline{\text{RESET}}$ low and placing the decoder into a reset state. At the rising edge of $\overline{\text{RESET}}$ the $\overline{\text{ABOOT}}$, $\overline{\text{WR}}$, and $\overline{\text{RD}}$ pins are sampled. If $\overline{\text{ABOOT}}$ is low when sampled, and the $\overline{\text{WR}}$ and $\overline{\text{RD}}$ pins are set to configure the device for serial communications, the device will begin to autoboot. Section 2.1 discusses the procedure required for placing the CS492X into a serial communication mode. For a more thorough description of $\overline{\text{ABOOT}}$'s behavior after the rising edge of $\overline{\text{RESET}}$ please see section 3.2.1

The $\overline{\text{EMOE}}$ pin of the CS492X is used for two purposes. It generates clock pulses for the latches, and it is used in conjunction with $\overline{\text{EXTMEM}}$ to enable the outputs of the ROM. The first three rising edges of $\overline{\text{EMOE}}$ are used to latch address bytes, as shown in the diagram. The fourth low pulse of $\overline{\text{EMOE}}$ is used to enable the ROM outputs. When both $\overline{\text{EXTMEM}}$ and $\overline{\text{EMOE}}$ go low, the EMAD[7:0] pins of the DSP become inputs and await the data coming from the ROM.

When comparing the memory system in Figure 15 to the timing diagram of Figure 16 there may

appear to be a discrepancy. The timing diagram shows three address cycles, but there are only two latches in the illustration of the memory architecture. This difference is a result of code size limitations. The application code is guaranteed to fit into a 32 Kilobyte space, which means that only 15 address bits will actually be used for retrieving code from the ROM. Thus, the two latches catch the least significant bytes, and the most significant byte is dropped.

In autoboot mode, latching the most significant byte would be perfectly valid since the most significant bits are guaranteed to be zeros (the three bytes represent a true 24-bit address). If the external memory is to be used for access during run-time (such as in DTS decode), however, a third latch would break the memory interface. Different external memory interface schemes are discussed in more detail in Section 4.

The flow chart given in Figure 17 demonstrates the interaction required by the microcontroller when placing the DSP into autoboot mode. The host must first drive the $\overline{\text{RESET}}$ line low. The host also drives $\overline{\text{ABOOT}}$ low and hold it in a low state until the rising edge of $\overline{\text{RESET}}$. The low state of $\overline{\text{ABOOT}}$ at the rising edge of $\overline{\text{RESET}}$ initiates autoboot. As noted on the diagram, the host control mode must be configured for serial communications, and the appropriate setup (T_{rstsu}) and hold (T_{rsthd}) times must be observed.

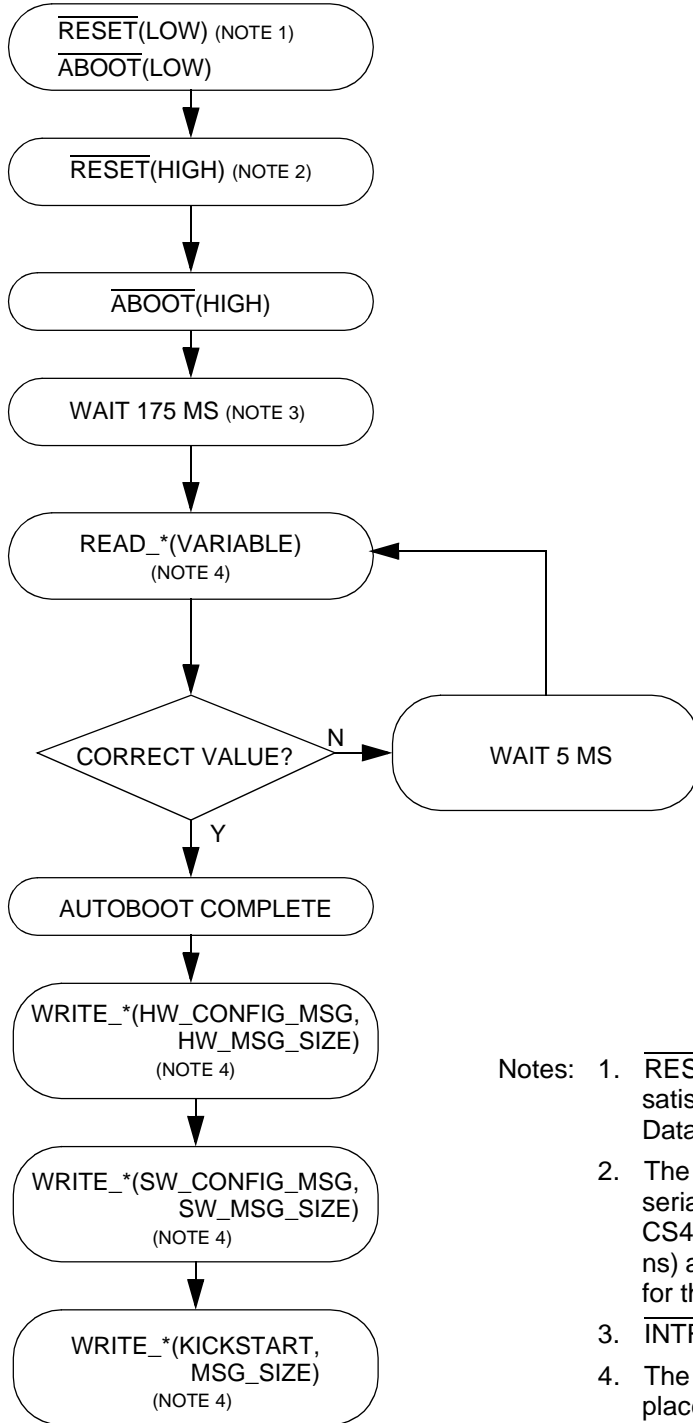

- Notes:
1. $\overline{\text{RESET}}$ must be held LOW for at least 100 ns to satisfy the T_{rstl} as specified in the CS4923/4/5/6/7/8/9 Datasheet.
 2. The $\overline{\text{RD}}$ and $\overline{\text{WR}}$ pins must be configured to select a serial communication mode as defined in the CS4923/4/5/6/7/8/9 Datasheet. The setup ($T_{rstsu} = 50$ ns) and hold ($T_{rsthd} = 15$ ns) times must be observed for the $\overline{\text{RD}}$, $\overline{\text{WR}}$, and $\overline{\text{AUTOBOOT}}$ pins.
 3. $\overline{\text{INTREQ}}$ should be ignored during this period.
 4. The READ_* and WRITE_* functions are placeholders for the $\text{READ_I2C}/\text{READ_SPI}$ and $\text{WRITE_I2C}/\text{WRITE_SPI}$ functions defined in the Serial Communication section.

Figure 17. Autoboot Sequence

Because $\overline{\text{ABOOT}}$ must be driven by the host with an open-drain pin, the statement $\overline{\text{ABOOT}}(\text{HIGH})$ should be understood to mean $\overline{\text{ABOOT}}(\text{RELEASE})$. The pull-up resistor required on the $\overline{\text{ABOOT}}$ (or $\overline{\text{INTREQ}}$) line will always be responsible for producing a high value on the pin. $\overline{\text{ABOOT}}$ should never be driven high by the host.

After waiting for 175ms, the download should have completed. During the wait period, the host should ignore all $\overline{\text{INTREQ}}$ behavior (mask the $\overline{\text{INTREQ}}$ interrupt). The host can then verify that the code has successfully initialized itself by reading a variable from the application and checking the returned value against the known default value. Any variable can be used for the verification step, but a robust design will select a variable whose value is neither all 0's nor all 1's. If the first read attempt returns an incorrect value, a 5ms wait should be inserted and the read should be repeated. If a second invalid number is read, the entire boot process should be repeated. When the number returned matches the default value for the variable read, the host can be confident that the application is resident in the DSP and awaiting further instruction.

Hardware configuration messages are used to define the behavior of the DSP's audio ports. A more detailed description of the different hardware configurations can be found in the Section 5 "Hardware Configuration" -- page 46.

The software configuration messages are specific to each application (AC-3, MPEG, Crystal Original Surround, and DTS). The user's guide for each application provides a list of all pertinent configuration messages. Writing the KICKSTART message to the CS492X begins the audio decode process. The KICKSTART message will also be described in the user's guide for each application. Until the KICKSTART has been sent, the decoder is in a wait state.

3.2.1 Autoboot $\overline{\text{INTREQ}}$ Behavior

It is important to note that $\overline{\text{ABOOT}}$ and $\overline{\text{INTREQ}}$ are multiplexed on pin 20 of the CS492X. Because this pin serves as an input before reset, and an output after reset, the host should release the $\overline{\text{ABOOT}}$ line after $\overline{\text{RESET}}$ has gone high. As shown in Figure 18, the host must drive $\overline{\text{ABOOT}}$ low around the rising edge of $\overline{\text{RESET}}$, while observing the T_{rstsu} and T_{rsthd} timing parameters given in the CS492X Family Data Sheet in order to initiate an autoboot sequence.

After the host has released the $\overline{\text{ABOOT}}$ line, it will remain high while the DSP prepares to load code into itself. When the DSP has begun the boot process $\overline{\text{INTREQ}}$ ($\overline{\text{ABOOT}}$) will be driven low and it will remain low during the entire download procedure. $\overline{\text{INTREQ}}$ should be ignored during download, i.e. interrupts should be masked on the host. The download time will vary according to the size of the download image and the frequency of

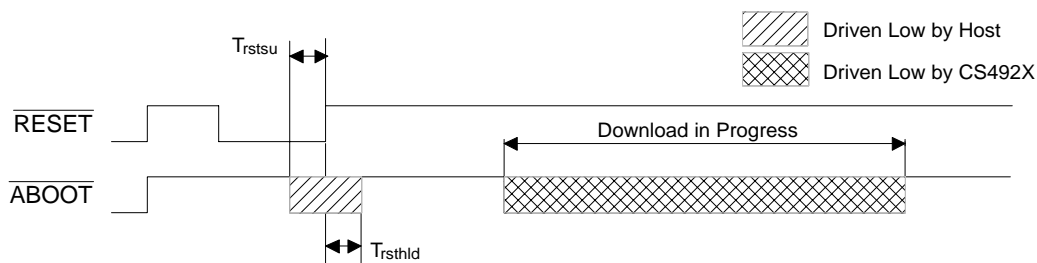

Figure 18. Autoboot $\overline{\text{INTREQ}}$ Behavior

the main DSP clock. At the conclusion of autoboot, the DSP issues an internal reset which will cause $\overline{\text{INTREQ}}$ to rise, indicating that boot has completed. The autoboot sequence is guaranteed to complete in 175ms (from rising edge of $\overline{\text{RESET}}$ to the internal reset of the CS492X).

3.3 Application Failure Boot Message

Each piece of application code is specifically tailored for either the CS4923, CS4924, CS4925, CS4926, CS4927, CS4928 or CS4929. Although it is possible to load a piece of code into the wrong chip and receive a `BOOT_SUCCESS` byte, the code will not initialize itself. In order to facilitate the debug of designs which can accept many members of the CS492X family, an `APPLICATION_FAILURE` message is provided.

As mentioned earlier, the host should wait for at least 5ms after download before sending configuration messages to the CS492X. This

provides time for the code to initialize itself. If the $\overline{\text{INTREQ}}$ pin is low 1ms after the download process has completed, the host should read from the CS492X. The byte `0xF0` indicates `APPLICATION_FAILURE`. This byte informs the host that the application code was loaded into an incompatible DSP. As an example, loading DTS application code into the CS4923 will generate an `APPLICATION_FAILURE` byte.

Although most boot messages are essentially ignored for autoboot, it should be noted that the `APPLICATION_FAILURE` message is applicable whether serial boot or autoboot is used.

3.4 Resetting the CS4923/4/5/6/7/8/9

Resetting the CS492X uses a combination of software and hardware. To reset the device, a previous application must have been downloaded. The flow diagram in Figure 19 shows the procedure for performing a reset.

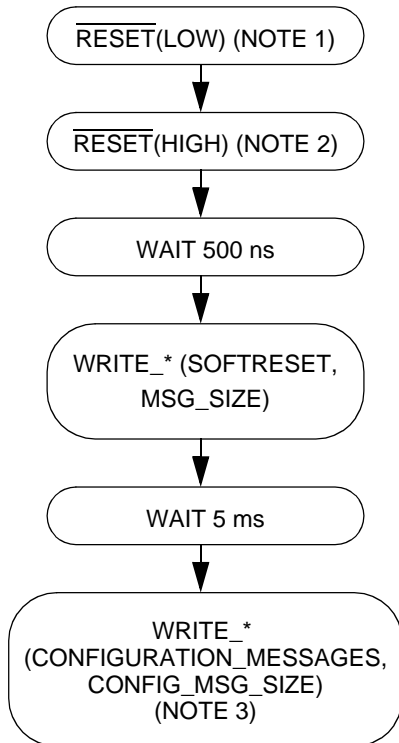

- Notes:
1. $\overline{\text{RESET}}$ must be held LOW for at least 100 ns to satisfy t_{rstl}
 2. It should be noted that mode pins are used to configure the CS492X communication mode. These mode pins are latched internally on the rising edge of reset and can be set dynamically by a microprocessor or can be statically pulled HIGH or LOW. If these pins are driven dynamically, setup and hold times must be satisfied as stated in the CS492X Datasheet. More information about the function of the mode pins can be found in the CS492X Datasheet and in Section 2 "Host Communication" -- page 8,
 3. Configuration messages determine both hardware and software configuration. Hardware configurations are described in **section 5** of this manual. Software application configuration messages are described in the Application Code User's Guide for the code being used.

Figure 19. Performing a Reset

The following is a detailed description of a reset sequence to the CS492X. All writes and reads with the CS492X should follow the protocol given in Section 2 “Host Communication” -- page 8, and timing given in the CS492X Datasheet.

- 1) Reset begins when the host issues a hard reset and holds the mode pins appropriately (\overline{WR} , \overline{RD} , and PSEL) as described in Section 2 “Host Communication” -- page 8 and in the CS492X Datasheet. It is assumed that the communication protocol is followed for whichever communication mode is chosen by the host and that timing is satisfied per the CS492X Datasheet.
- 2) The host should then send the message SOFT_RESET (0x000001). This will restart the previously downloaded application with all

of the hardware configurations in their default states. The Application Code User’s Guide for each application lists those parameters which are affected by a SOFT_RESET.

- 3) After waiting 5 ms to allow the downloaded application to initialize, the host can send configuration messages for both hardware and software configuration. Hardware configuration messages are described in Section 5 “.Hardware Configuration” -- page 46. Software application configuration messages are described in the Application Code User’s Guide for the code being used.

The pseudocode in Section 6.4 “Typical Reset Sequence for the CS4923/4/5/6/7/8/9” -- page 65 demonstrates a typical reset sequence for the CS492X.

4. EXTERNAL MEMORY

The CS492X family of DSPs provide a byte-wide interface for accessing external memory. The basic memory interface is implemented with the following pins: EMAD[7:0], $\overline{\text{EXTMEM}}$, $\overline{\text{EMOE}}$, and $\overline{\text{EMWR}}$. Each pin has been described in Table 9.

The host communication mode is important when considering the external memory interface. External memory can only be connected to those systems which implement a serial control host interface. Any systems using the parallel host cannot use the external memory interface.

The entire family of decoders has the capability of autobooting, as discussed in Section 3.2 External memory is used to hold the application code that the DSP will load into itself. Because the CS4923, CS4924, CS4925 and CS4929 do not require Autoboot capability, external memory is optional.

The CS4926 and CS4928, however, *require* the use of external memory. An external ROM must be used for holding the DTS look-up tables employed by the CS4926 and CS4928 during the decode of a DTS bit-stream. Table 10 lists the memory configurations for each decoder.

In a simple system, a non-paged memory can be used to hold a single piece of autoboot code or the DTS tables alone (e.g., the CS4928). In more complex systems, a paged memory architecture can be used to hold multiple pieces of application code and the DTS tables (e.g., the CS4926). Both memory architectures, paged and non-paged, will be presented in detail later in this section.

Pin Name	Pin Number	Pin Function
EMAD0	17	Multiplexed Address and Data Bit 0
EMAD1	16	Multiplexed Address and Data Bit 1
EMAD2	15	Multiplexed Address and Data Bit 2
EMAD3	14	Multiplexed Address and Data Bit 3
EMAD4	11	Multiplexed Address and Data Bit 4
EMAD5	10	Multiplexed Address and Data Bit 5
EMAD6	9	Multiplexed Address and Data Bit 6
EMAD7	8	Multiplexed Address and Data Bit 7
$\overline{\text{EXTMEM}}$	21	External Memory Select
$\overline{\text{EMOE}}$	5	* External Memory Output Enable & Address Latch Strobe
$\overline{\text{EMWR}}$	4	* External Memory Write Strobe

* - These pins must be configured appropriately to select a serial host communication mode for the CS4923/4/5/6/7/8/9 at the rising edge of RESET

Table 9. Memory Interface Pins

Part Number	Host Control Mode if using External ROM	Memory Usage
CS4923,4,5,7,9	I ² C or SPI	OPTIONAL – Autoboot mode
CS4926,8	I ² C or SPI	REQUIRED – DTS Tables OPTIONAL – Autoboot mode

Table 10. Memory and Control Requirements for the CS4923/4/5/6/7/8/9 Family

4.1 Basic Memory Architecture

The simplest external memory system consists of the DSP's memory interface, the external memory, and two octal latches to hold the memory address. This configuration is a non-paged memory architecture, and a block diagram of this system is shown in Figure 20. Non-paged memories are ideal for autobooting a single piece of application code such as AC-3. Because the application code is guaranteed to fit within a 32 Kilobyte space, it is only necessary to provide 15 address bits. The 16th address bit coming from the DSP may, however, be connected to the memory since the most significant bit is guaranteed to always be 0 during autoboot. Figure 21 shows the functional timing of an autoboot sequence in which three address cycles are illustrated. Due to the code size limitation, however, only the lower 15 bits of this address are relevant.

The CS4926 and CS4928 both have special memory requirements since they must access look-up tables while processing DTS encoded audio. These tables will reside in a 64 Kilobyte page of external memory. The memory architecture illustrated in Figure 20 is also applicable for the

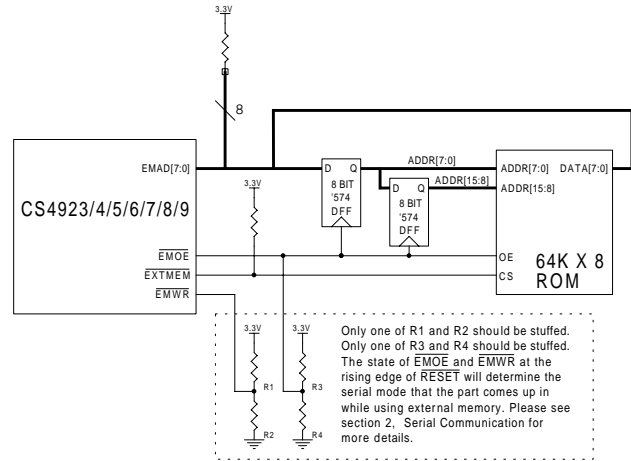

Figure 20. Basic Memory Architecture

DTS tables since only 16 bits are necessary for addressing all 64 Kilobytes. The timing requirements for the memory used in a DTS system, however, are different from the timing requirements of the memory used for autoboot only. Accesses made during run-time occur at a higher frequency, and there are only two address cycles as can be seen in Figure 22. Consequently, a DTS system requires a faster ROM.

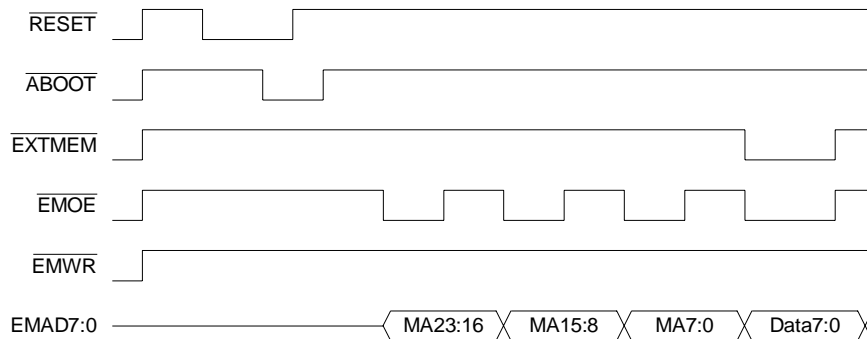

Figure 21. Autoboot Timing Diagram

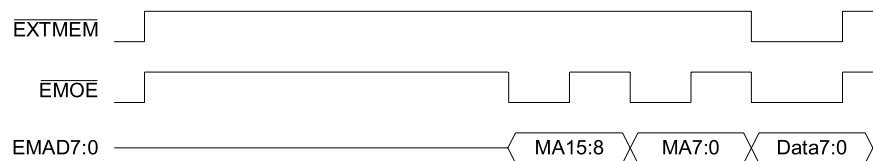

Figure 22. Run-Time Memory Access

Table 11 lists the memory speed requirements based on the ROM content.

ROM Content	ROM Speed
AUTOBOOT Code	330ns
DTS Tables Only	110ns
AUTOBOOT Code & DTS Tables	110ns

Table 11. ROM Speeds

4.2 Non-Paged Memory

A non-paged memory architecture should be used in systems which will need to access 64 Kilobytes of data or less. One example of such a system would be a decoder designed for AC-3 autoboot only. In this case the only code ever needed would be the application code that would run on the CS4923 or the CS4924. The code is constrained to occupy less than 32 Kilobytes of memory, which means that only 15 bits would be required to access the entire image. Therefore a single-code autoboot system could use the 16-bit addressing scheme shown in Figure 20.

Another possible scenario is a CS4926 or CS4928 DTS decoder which will be booted by the host. In this system only a 64 Kilobyte ROM would be necessary for holding the look-up tables. Once again, the basic memory architecture presented in Figure 20 would be adequate.

The DSP *always* considers its address space to range from 0x0000 to 0xFFFF. This means that the decoder is unaware of any data which falls outside of these 64 Kilobytes. In autoboot mode there is yet another constraint – the autoboot process always begins with address 0x0000. The implication is that the host microcontroller must somehow be involved in memory accesses which exceed the 64 Kilobyte scope of the CS492X, and the host must also manage access to all pieces of autoboot code which do not physically reside at location 0x0000. The limitations of a non-paged memory are easily seen, and they can be circumvented using paged memory designs as discussed in the next section.

4.3 Paged Memory

A paged memory architecture is necessary for those systems which provide autoboot for multiple code loads (e.g. when using Autodetect), or in any CS4926 or CS4928 system which utilizes autoboot.

Paged memory is defined as a large memory partitioned into smaller blocks. The easiest partitioning scheme for the CS4923/4/5/6/7/8/9 family is on 64 Kilobyte boundaries because of the sixteen bits of address provided by the DSP. If memory space is at a premium, and the system under design does *NOT* use the CS4926 or the CS4928, it *is* possible to perform paging on 32 Kilobyte boundaries.

The host microcontroller plays a crucial role in paged memory systems, since it is directly responsible for addressing each page. In a memory composed of 64 Kilobyte pages, the high order address bits of the ROM, A16 and A17, would be controlled directly by the microcontroller as shown in Figure 23. These two address lines give the host the capability to select any of four 64 Kilobyte pages in memory.

A memory with 32 Kilobyte pages can be used only to hold autoboot code. Such a memory would be paged with bits A15 and A16. Using this design template, it is vital that the most significant address bit latched from the DSP, A15, not be connected to the memory. The host microcontroller is responsible for controlling address bits A15 and greater. A 32 Kilobyte design is presented in Figure 24.

The main variable in organizing the ROM is the page size. The easiest way to determine the page size for your system is to look at the largest block of memory required for any operation. If the external ROM is designed to hold only autoboot code, the designer has the option of using either 32 Kilobyte or 64 Kilobyte pages. The final decision would depend upon the size of the memory which will be used in the final design.

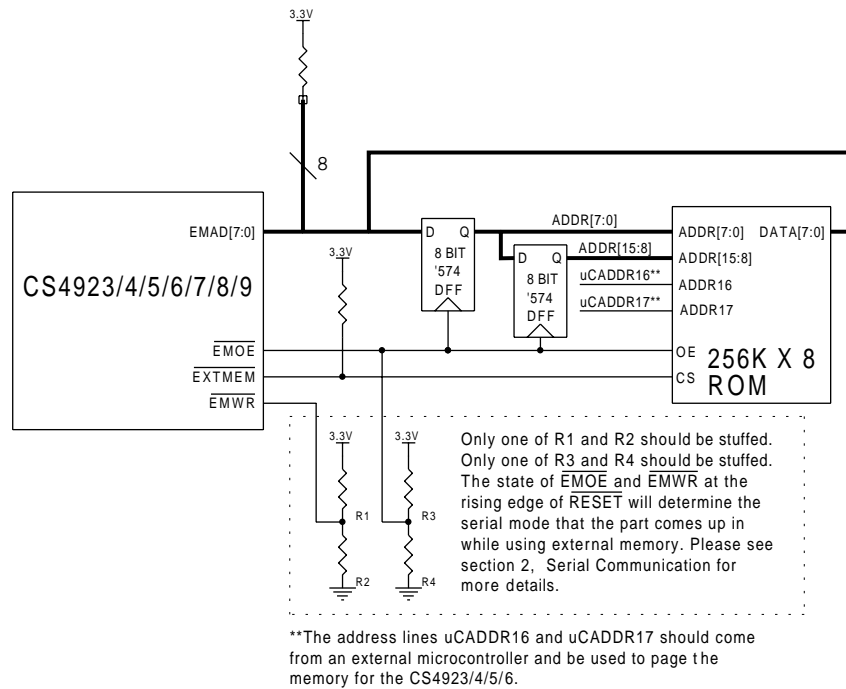

Figure 23. External Memory with 64 Kilobyte Pages

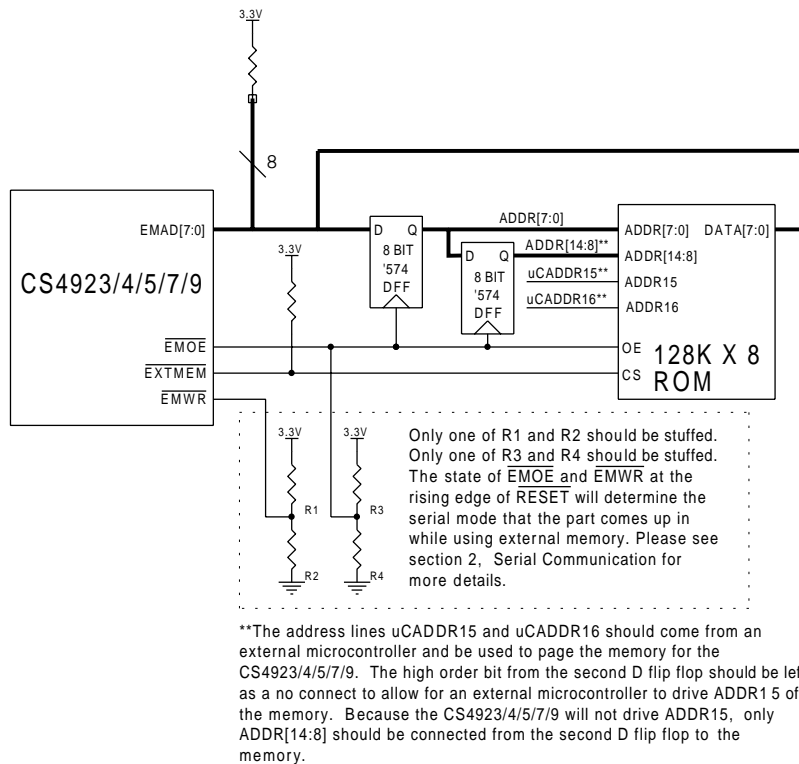

Figure 24. External Memory With 32 Kbyte Pages

ROM Content	Image Size	Number of Pages Required	Recommended Page Size
CS4923			
AC-3	32 Kbytes	1	Non-Paged
AC-3, Crystal Original Surround	32 + 32 = 64 Kbytes	2	32 Kbytes or 64 Kbytes
CS4924			
AC-3	32 Kbytes	1	Non-Paged
AC-3 with Q-Sound	32 Kbytes	1	Non-Paged
CS4925			
AC-3, MPEG Multi-Channel, Crystal Original Surround	32 + 32 + 32 = 96 Kbytes	3	32 Kbytes or 64 Kbytes
CS4926			
DTS Tables	64 Kbytes	1	Non-Paged
DTS Tables, DTS, AC-3, Crystal Original Surround	64 + 32 + 32 + 32 = 160 Kbytes	4	64 Kbytes
CS4927			
MPEG Multi-Channel	32 Kbytes	1	Non-Paged
MPEG Multi-Channel, Crystal Original Surround	32 + 32 = 64 Kbytes	2	32 Kbytes or 64 Kbytes
CS4928			
DTS Tables	64 Kbytes	1	Non-Paged
DTS Tables, DTS, Crystal Original Surround	64 + 32 + 32 = 128 Kbytes	3	64 Kbytes
CS4929			
AAC 2-Channel	32 Kbytes	1	Non-Paged
AAC 2-Channel, MPEG Stereo	32 + 32 = 64 Kbytes	2	32 Kbytes or 64 Kbytes

Table 12. External Memory Configurations

A system using a CS4926 or CS4928, however, will always require a 64 Kilobyte page for the DTS look-up tables. Thus, the most straightforward externally paged ROM for an autobooting CS4926 or CS4928 would have 64 Kilobyte pages. The CS4926 or CS4928 would control the lowest sixteen bits of address, and the host microcontroller would control the most significant address bits.

Table 12 lists possible external memory configurations for each DSP. The table provides a list of the ROM content, the size of the combined memory images, the recommended page size, and the number of discrete pages required. The page sizes were calculated using the methodology discussed previously. A more complex memory scheme is given in the CRD4923-MEM example (Figure 32), which demonstrates how to pack the

memory more efficiently in a DTS system. The examples also include several figures which present the different ROM configurations as composite memory images.

4.4 Examples

4.4.1 Non-Paged Memory

The most rudimentary memory design discussed above is the non-paged memory. In a non-paged design, the DSP can only access one item in memory which could be either a single autoboot code load, or the DTS tables for the CS4926 or CS4928. The memory image given in Figure 25 is an example of a non-paged memory image.

The memory image shown above would be designed into a system using the memory architecture laid out in Figure 20. All 16 output bits

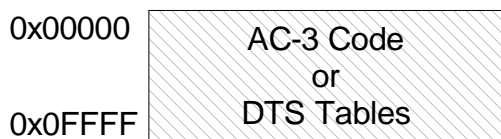

Figure 25. Non-Paged Memory

of the address latches would be connected to address bits A0-A15 of the external ROM. The host is completely isolated from memory accesses in this situation. Once the hardware has been designed, the DSP itself will be responsible for all communication with the ROM.

4.4.2 32 Kilobyte Paged Autoboot Memory

An external memory architecture which is paged on 32 Kilobyte boundaries will necessarily contain only autoboot code. Therefore, this architecture can only be used by the CS4923/4/5/7/9. Because of the 64 Kilobyte look-up table that must be used during the decode of a DTS stream, the CS4926 and CS4928 could *never* be used with a *fixed* 32 Kilobyte page size. Figure 26 shows an example of a 32 Kilobyte paged memory image.

The flow diagram given in Figure 27 demonstrates the interaction required by the microcontroller during autoboot. After placing the decoder into a reset state, the host selects the page in memory containing AC-3 Code by driving $\overline{uC15}$ to a low state. The host also drives \overline{ABOOT} low and holds it in a low state until the rising edge of \overline{RESET} to initiate autoboot. As noted in the autoboot section, the \overline{ABOOT} pin should be connected to an open-drain output of the microcontroller so as to allow the specified pull-up resistor to generate the high

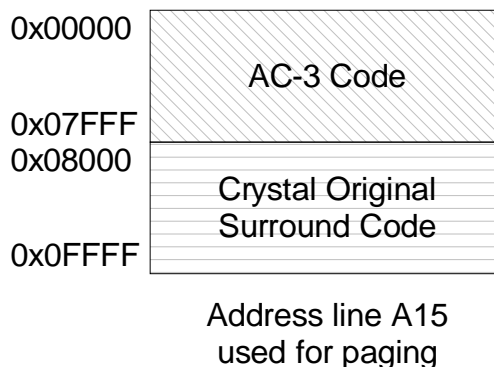
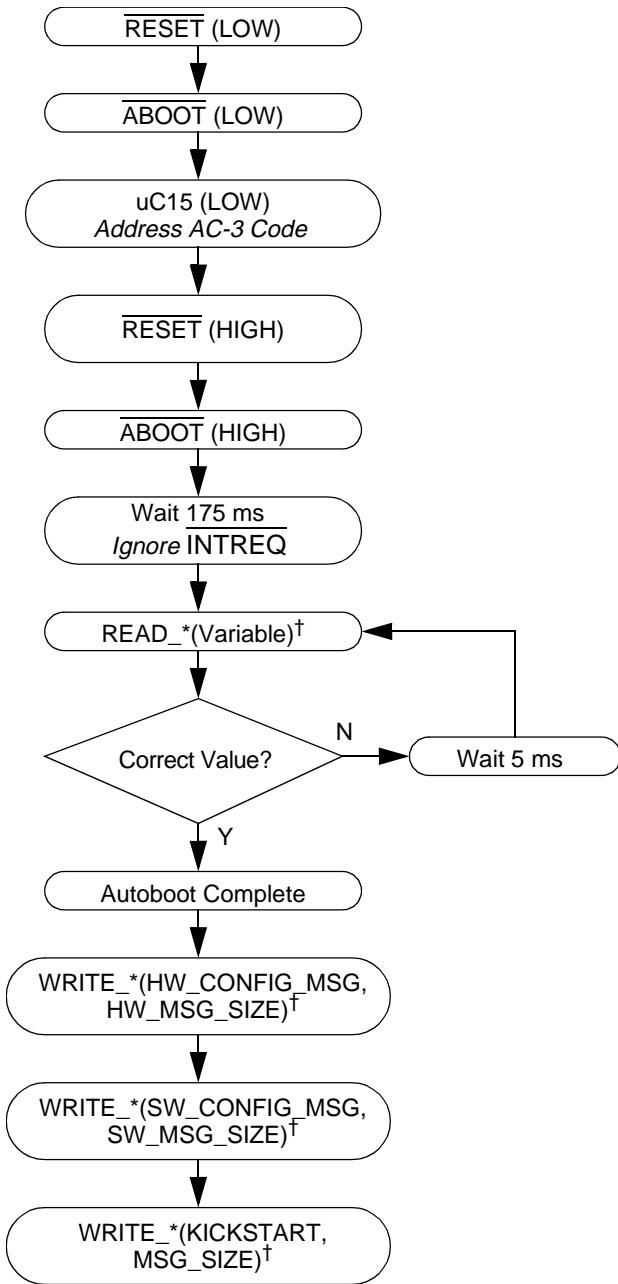

Figure 26. 32 Kbyte Paged memory

value. The open-drain driver is required because the DSP will begin using the pin as an output after a successful download (\overline{INTREQ} and \overline{ABOOT} are multiplexed on the same pin).

After waiting for 175 ms the download should have completed. During the wait period, the host should ignore all \overline{INTREQ} behavior (mask the \overline{INTREQ} interrupt). The host can then verify that the code has successfully initialized itself by reading a variable from the application and checking the returned value against the default value. Any variable can be used for the verification step, but a robust design will select a variable whose value is neither all 0's nor all 1's. If the first read attempt returns an incorrect value, a 5 ms wait should be inserted and the read should be repeated. If a second invalid number is read, the entire boot process should be repeated. When the number returned matches the default value for the variable read, the host knows that the application is resident in the DSP and awaiting further instruction. Please see Section 3.2 "Autoboot" -- page 28 for more information.



†The READ_* and WRITE_* functions are placeholders for the READ_I2C/READ_SPI and WRITE_I2C/WRITE_SPI functions defined in the Serial Communications section.

Figure 27. Autboot Sequence for 32 Kbyte Paged Memory

4.4.3 64 Kilobyte Paged Autboot Memory

Systems using *fixed* page sizes can implement either 64 Kilobyte or 32 Kilobyte pages when the audio decoder is one of the CS4923/4/5/7/9, but the CS4926 and CS4928 are restricted to 64 Kilobyte pages. The larger page size adds more versatility to the system design because both autboot code and DTS tables can be included in any external ROM utilizing 64 Kilobyte pages. The next two examples show possible memory designs. The first memory image contains only autboot code, and the second example shows an external ROM image which holds multiple pieces of autboot code in addition to the DTS look-up tables.

The memory image illustrated in Figure 28 is designed for a system using external ROM for autboot purposes only. There are only two pages to choose from, which means that the host microcontroller needs to drive one memory address line. In this case, it would be bit A16. The architecture for this memory configuration is shown in Figure 23. All 16 bits of latched address are connected to the memory, and the microcontroller would provide uC16 for paging between the AC-3 Code and Crystal Original Surround.

The flow diagram given in Figure 29 demonstrates the interaction required by the microcontroller when placing the DSP into autboot mode. After placing the decoder into a reset state, the host selects the page in memory containing Crystal Original

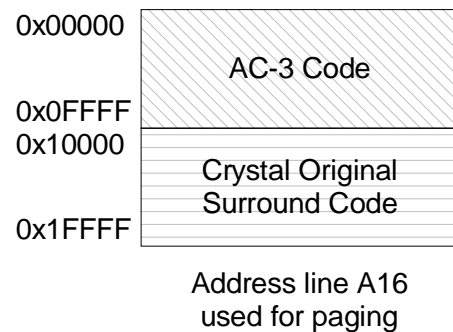

Figure 28. 64 Kbyte Paged Autboot Memory

Surround Code by driving $\overline{\text{uC16}}$ to a high state. The host also drives $\overline{\text{ABOOT}}$ low and holds it in a low state until the rising edge of $\overline{\text{RESET}}$ to initiate autoboot. As noted in the autoboot section, the $\overline{\text{ABOOT}}$ pin should be connected to an open-drain output of the microcontroller so as to allow the specified pull-up resistor to generate the high value. The open-drain driver is required because the DSP will begin using the pin as an output after a successful download ($\overline{\text{INTREQ}}$ and $\overline{\text{ABOOT}}$ are multiplexed on the same pin).

After waiting for 175 ms the download should have completed. During the wait period, the host should ignore all $\overline{\text{INTREQ}}$ behavior (mask the $\overline{\text{INTREQ}}$ interrupt). The host can then verify that the code has successfully initialized itself by reading a variable from the application and checking the returned value against the default value. Any variable can be used for the verification step, but a robust design will select a variable whose value is neither all 0's nor all 1's. If the first read attempt returns an incorrect value, a 5 ms wait should be inserted and the read should be repeated. If a second invalid number is read, the entire boot process should be repeated. When the number returned matches the default value for the variable read, the host knows that the application is resident in the DSP and awaiting further instruction. Please see Section 3.2 "Autoboot" -- page 28 for more information.

4.4.4 64 Kilobyte Paged DTS & Autoboot Memory

The memory image of Figure 30 provides one example of a ROM configuration for external memory which contains multiple autoboot code loads in addition to the look-up tables required for DTS decode. The four pages in memory are each 64 Kilobytes in size. The symmetry of this design simplifies the necessary address logic when compared to the CRD4923-MEM design discussed later in this section. The host can select any page in

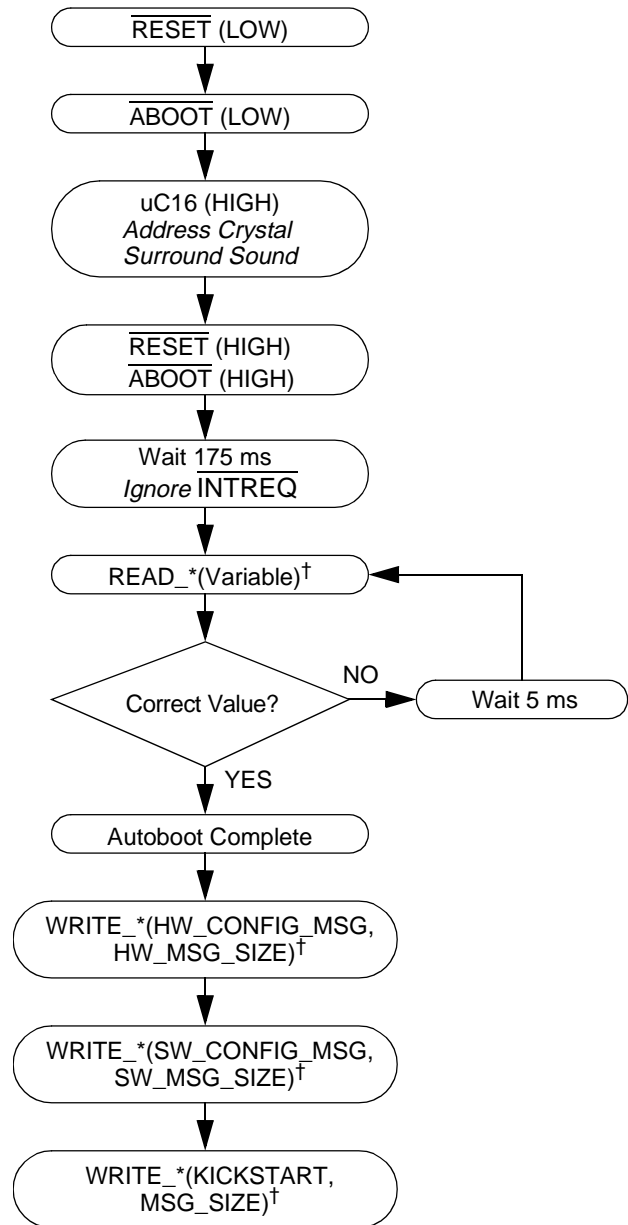

†The READ_* and WRITE_* functions are placeholders for the READ_I2C/READ_SPI and WRITE_I2C/WRITE_SPI functions defined in the Serial Communication section.

Figure 29. Autoboot for 64 Kbyte paged Memory

memory by toggling the A16 and A17 address bits of the external memory.

Figure 31 shows the sequence of actions required for performing an autoboot in a DTS system (CS4926 or CS4928). Note the similarities to the flow chart for a simple autoboot system. This memory arrangement requires an additional address bit, uC17, and memory must be paged to the DTS Tables before KICKSTARTing the DTS decode application.

After placing the decoder into a reset state, the host selects the page in memory containing the DTS Code by driving uC16 to a low state, and uC17 to a high state. The host also drives \overline{ABOOT} low and holds it in a low state until the rising edge of \overline{RESET} to initiate autoboot. As noted in the autoboot section, the \overline{ABOOT} pin should be connected to an open-drain output of the microcontroller so as to allow the specified pull-up resistor to generate the high value. The open-drain driver is required because the DSP will begin using the pin as an output after a successful download (\overline{INTREQ} and \overline{ABOOT} are multiplexed on the same pin).

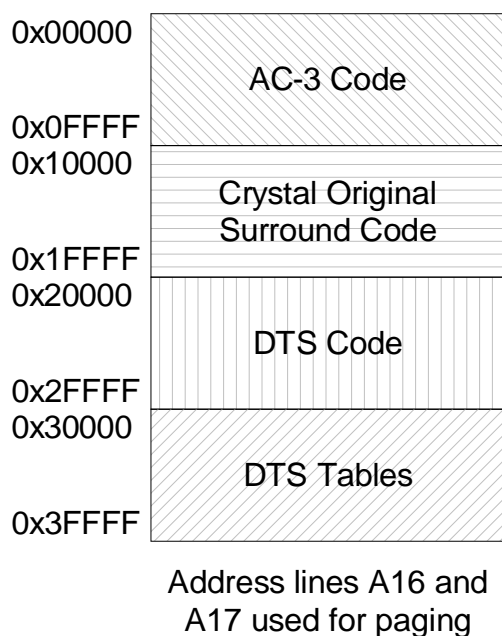

Figure 30. 64 Kbyte Paged DTS/Autoboot Memory

After waiting for 175 ms the download should have completed. During the wait period, the host should ignore all \overline{INTREQ} behavior (mask the \overline{INTREQ} interrupt). The host can then verify that the code has successfully initialized itself by reading a variable from the application and checking the returned value against the default value. Any variable can be used for the verification step, but a robust design will select a variable whose value is neither all 0's nor all 1's. If the first read attempt returns an incorrect value, a 5 ms wait should be inserted and the read should be repeated. If a second invalid number is read, the entire boot process should be repeated. When the number returned matches the default value for the variable read, the host knows that the application is resident in the DSP and awaiting further instruction.

DTS, unlike the other applications for the CS492X family, performs run-time accesses to the external memory. In order to ensure that the decoding process begins properly, the host should page to the DTS tables before sending a KICKSTART to the CS4926 or CS4928. The memory image in Figure 30 shows the DTS tables located at address 0x30000, so the host drives both uC16 and uC17 to a high state. After the address has been set, the host can move on to the configuration messages required for the final decoder setup. Please see Section 3.2 "Autoboot" -- page 28 for more information.

4.5 CRD4923-MEM

The CRD4923-MEM is an external memory adapter card designed for use with the CRD4923 and CDB4923. The schematic for the CRD4923-MEM is shown in Figure 32. In order to reduce the number of microcontroller lines needed for paging the memory and controlling the autoboot sequence, some 'glue logic' was added to the board. A consequence of this logic was a hybrid paging scheme. Both 32 Kilobyte and 64 Kilobyte pages are used in the external ROM found on the

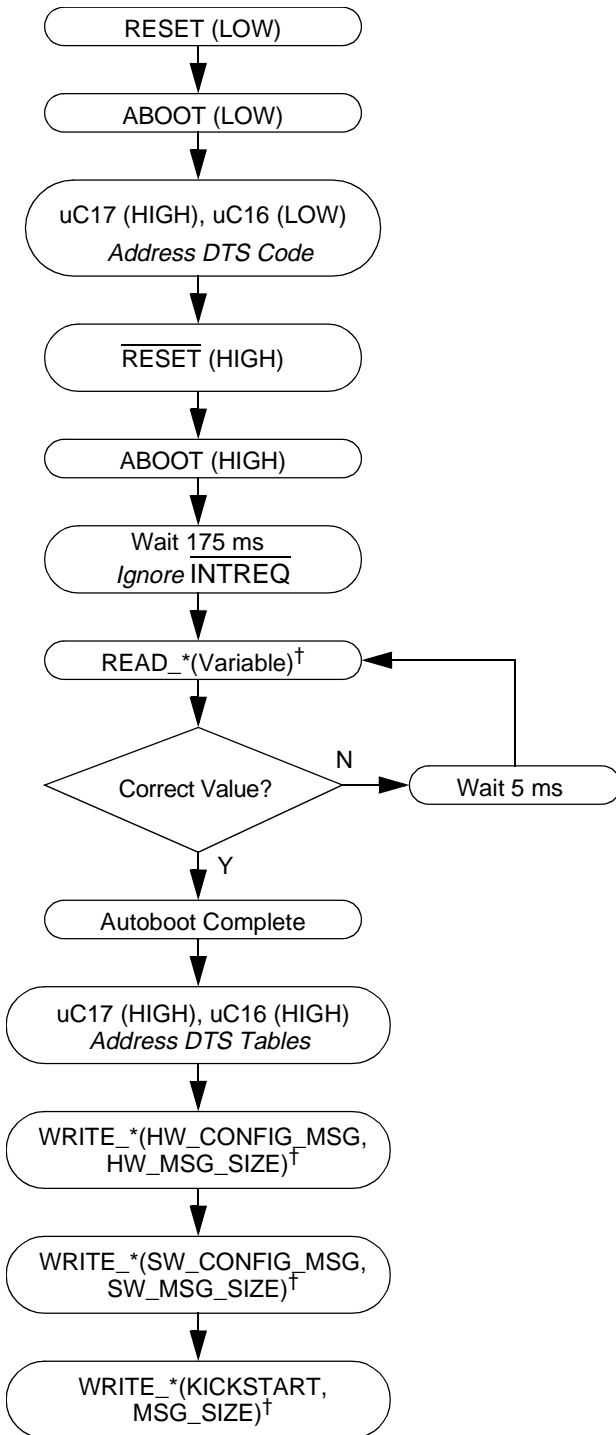

†The READ_* and WRITE_* functions are placeholders for the READ_I2C/READ_SPI and WRITE_I2C/WRITE_SPI functions defined in the Serial Communications section.

Figure 31. Autoboot Sequence for DTS System using Symmetrical 64 Kilobyte Pages

expander card. One example CRD4923-MEM memory image can be seen in Figure 33.

The aforementioned ‘glue logic’ was implemented with four tri-state buffers and the most significant address bit as shown in Figure 32. The high order address bit, uC17, is used to page between the Autoboot Sector and DTS Table Sector, as well as to initiate an autoboot sequence. The tri-state buffers are enabled and disabled according to the state of uC17, making the autoboot function address dependent.

When uC17 is high, the uC15 buffer and REQ23 buffer outputs are in a high impedance state, the DSP15 buffer is enabled, and the microcontroller is given control of only A16 and A17. This allows the CS4926 (or CS4928) to access all 64 Kbytes (A[15:0]) of the DTS Tables located in the upper half of external memory. In the DTS Sector of the memory there are only two 64 Kilobyte pages which are selected by uC16.

An autoboot sequence is activated when uC17 is driven low during reset. The uC15 and REQ23 buffers are enabled, and the REQ23 (ABOOT) line is driven low. Recall that holding ABOOT low during the rising edge of RESET signals the DSP to begin an autoboot sequence. Using uC17 in this fashion frees the microcontroller from dedicating an open-drain output for driving the ABOOT pin, but it also splits the memory into the Autoboot and DTS Sectors shown in Figure 33. The Autoboot Sector has four 32 Kilobyte pages which are selected with A15 and A16. While in the DTS Sector of memory, the DSP can access two different 64 Kilobyte pages with microcontroller address line uC16.

Obviously, the most complicated process involving external memory is autobooting the CS4926 or CS4928 into DTS mode. The microcontroller must first load the CS4926 with the DTS application code, and then page to the DTS Tables to ensure proper decode of DTS streams. The flow diagram

shown in Figure 34 illustrates the DTS autoboot process (CS4926 and CS4928 systems). Note that the control of the $\overline{\text{ABOOT}}$ line and the uC17 line are synonymous because of the glue logic used on the CRD4923-MEM.

After placing the decoder into a reset state, the host selects the page in memory containing the DTS Code by driving uC15 low, uC16 high, and uC17 to a low state. In the act of addressing autoboot code, the host also drives $\overline{\text{ABOOT}}$ low because of the relationship between uC17 and $\overline{\text{ABOOT}}$. The $\overline{\text{ABOOT}}$ pin is held in a low state until the rising edge of $\overline{\text{RESET}}$ to initiate autoboot. In fact, for the CRD4923-MEM, it is important that $\overline{\text{ABOOT}}$ (i.e. uC17) is not driven high until autoboot has completed. Placing uC17 into a high state would prevent the DSP from accessing the correct code. The tri-state buffer on the $\overline{\text{ABOOT}}$ line acts as an open-drain driver. The open-drain driver is required because the DSP will begin using the pin as an output after a successful download ($\overline{\text{INTREQ}}$ and $\overline{\text{ABOOT}}$ are multiplexed on the same pin).

After waiting for 175 ms the download should have completed. During the wait period, the host should ignore all $\overline{\text{INTREQ}}$ behavior (mask the $\overline{\text{INTREQ}}$ interrupt). The host can then verify that the code has successfully initialized itself by reading a variable from the application and checking the

returned value against the default value. Any variable can be used for the verification step, but a robust design will select a variable whose value is neither all 0's nor all 1's. If the first read attempt returns an incorrect value, a 5 ms wait should be inserted and the read should be repeated. If a second invalid number is read, the entire boot process should be repeated. When the number returned matches the default value for the variable read, the host knows that the application is resident in the DSP and awaiting further instruction.

DTS, unlike the other applications for the CS492X family, performs run-time accesses to the external memory. In order to ensure that the decoding process begins properly, the host should page to the DTS tables before sending a KICKSTART to the CS4926 or CS4928. The memory image in Figure 33 shows the DTS tables located at address 0x20000, so the host drives uC17 to a high state (this was required for releasing $\overline{\text{ABOOT}}$), and uC16 to a low state. In this state, with uC17 high, the DSP15 buffer has been enabled giving the decoder full access to all 64 Kbytes of the DTS look-up tables. After the address has been set, the host can move on to the configuration messages required for the final decoder setup. Please see Section 3.2 "Autoboot" -- page 28 for more information.

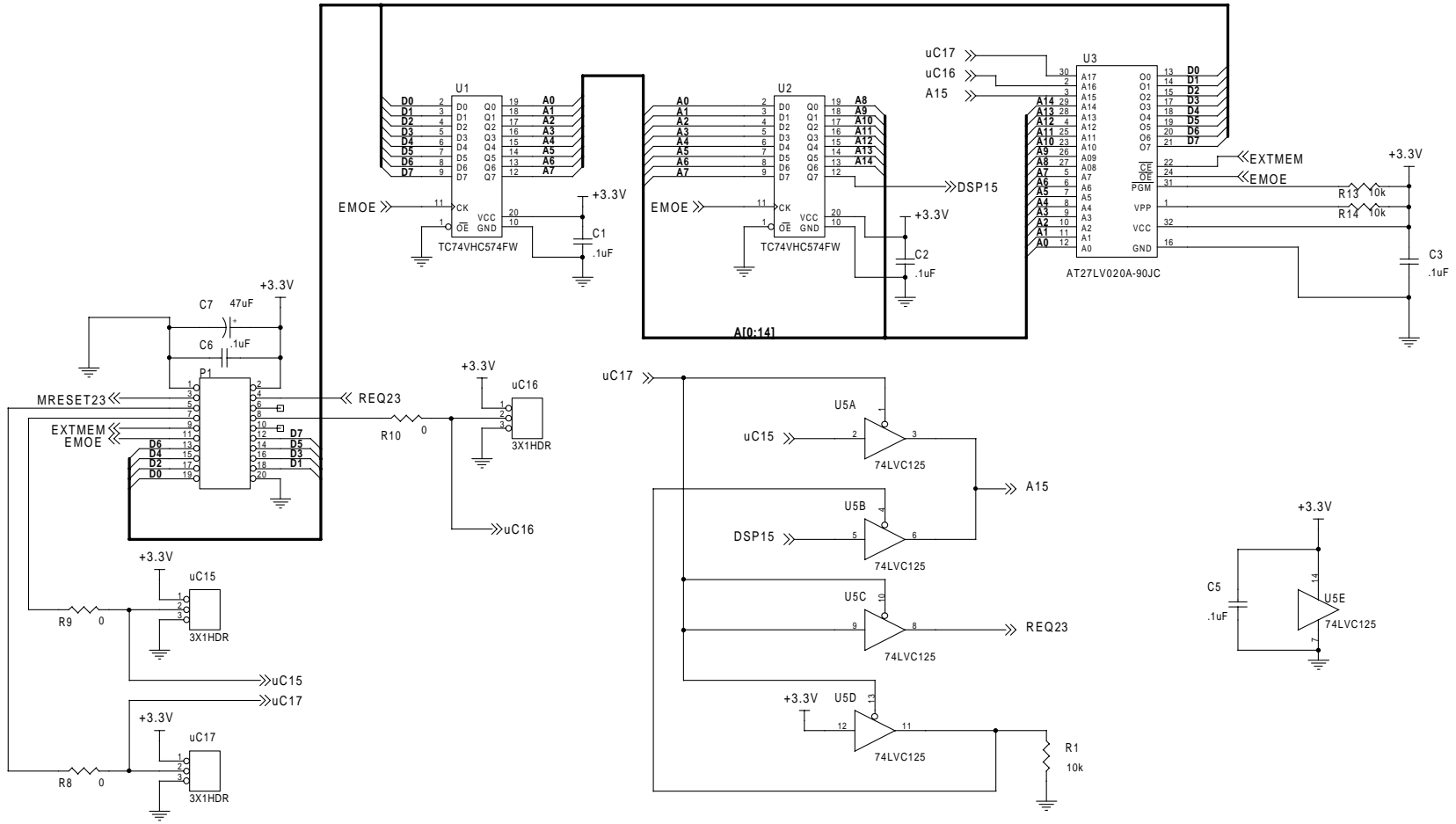
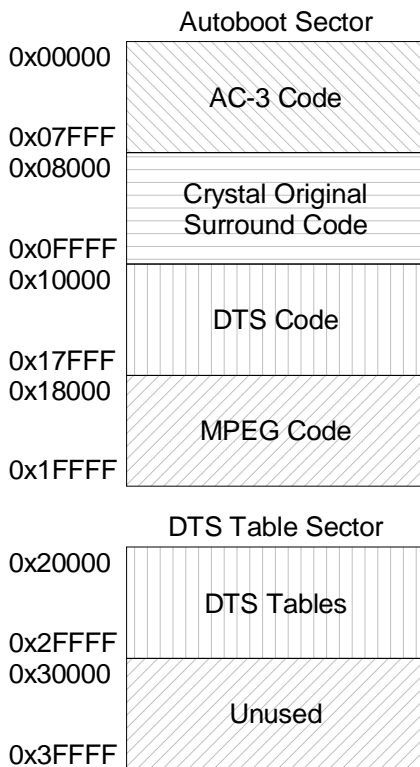

Figure 32. CRD4923-MEM

5. .HARDWARE CONFIGURATION

After download or soft reset, and before kickstarting the application (please see the Audio Manager in the Application Messaging Section of any Application Code User's Guide for more information on kickstarting), the host has the option of changing the default hardware configuration. Hardware configuration messages are used to physically reconfigure the hardware of the audio decoder, as in enabling or disabling address checking for the serial communication port. Hardware configuration messages are also used to initialize the data type (i.e., PCM or compressed) and format (e.g., I²S, left justified, etc.) for digital data inputs, as well as the data format and clocking options for the digital output port.



Address lines A15 and A16 page Autoboot Sector
Address line A17 selects DTS Tables or Autoboot

Figure 33. Memory Map for CRD4923 Daughter Board

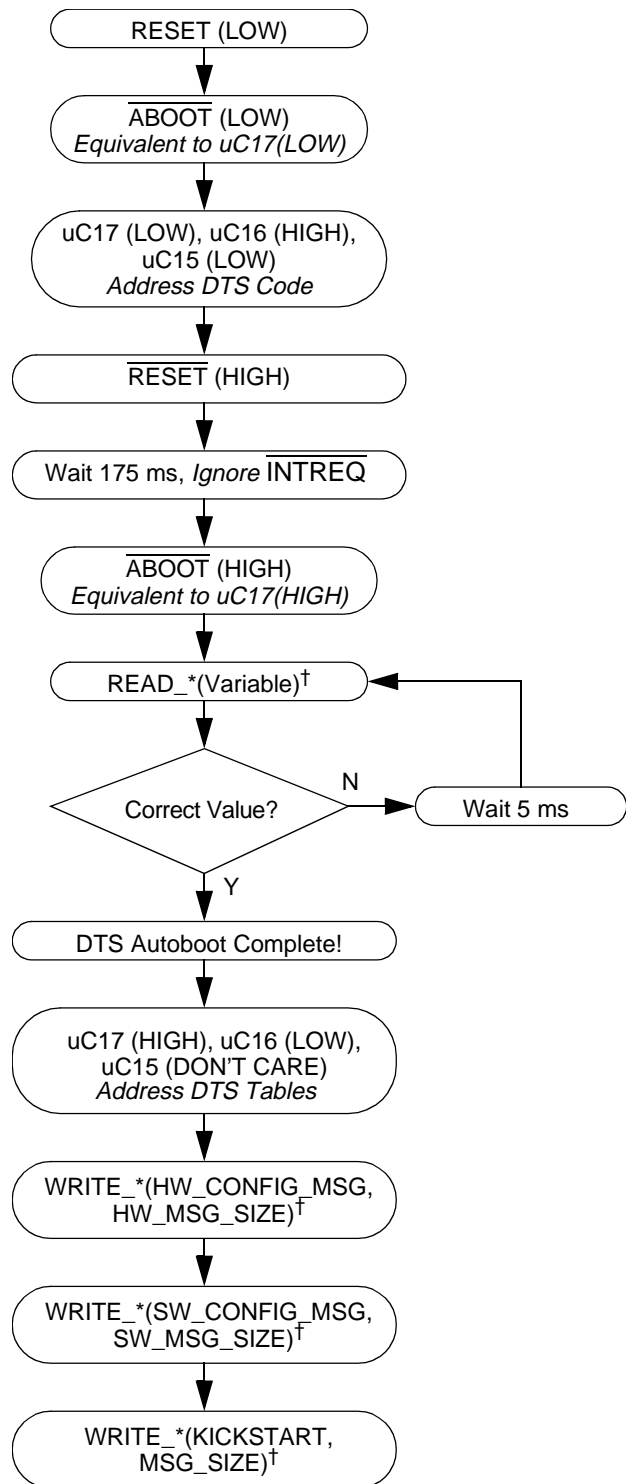

†The READ_* and WRITE_* functions are placeholders for the READ_I2C/READ_SPI and WRITE_I2C/WRITE_SPI functions defined in the Serial Communications section.

Figure 34. DTS Autoboot Flow Diagrams

In general, the hardware configuration can only be changed immediately after download or after soft reset. However, some applications provide the capability to change the input ports without affecting other hardware configurations after sending a special Application Restart message (please see the Audio Manager in any Application Code User's Guide to determine whether the Application Restart message is supported). Section 5.3 at the end of this chapter will describe how to construct a hardware configuration message.

5.1 Address Checking

When using one of the serial communication modes, I²C or SPI, as discussed in Section 2.1, it is necessary to send a 7-bit address along with a read/write bit at the start of any serial transaction. By default, address checking is enabled in the CS492X with an address of 0000000b. What this means is that all transactions starting with this address will be accepted by the CS492X communication port and all other communication will be ignored. The address checking portion of the hardware configuration message allows the host to enable or disable address checking as well as assign a unique address to the CS492X.

It should be noted that systems with multiple devices on the same bus require special consideration. Since the unique address can not be assigned until after download or reset, every device but one should be held in reset. That single device should then be brought out of reset, downloaded and assigned a unique address. The next device should then be brought out of reset and so on. This will insure that there is no contention on the bus and that the communication integrity is upheld. It should also be noted that performing a Soft Reset, as described in Section 3.4, will cause address checking to be re-enabled and the address will return to its default of 0000000b.

5.2 Input and Output

The CS492X has two input ports and one output port. This section will describe the digital audio formats supported by the ports and give a description of the ports themselves. The full capabilities of each port will be presented, although all configurations may not be currently supported by the software.

When configuring the input ports, both data format and data type must be considered. Data format is defined as the bit level presentation of the data, such as left justified or I²S. Data type refers to what the bits actually represent, such as AC-3 or PCM. It is the combination of these parameters that fully define the hardware configuration for the input ports. To allow for real-time data type changes, the hardware configuration of the input ports can be changed after a special run-time restart message (please see the Audio Manager in any Application Code User's Guide to determine whether the Application Restart message is supported). All other hardware configurations can change only immediately following download or a soft reset.

5.2.1 Digital Audio Formats

This subsection will describe some common audio formats that the CS492X supports. It should be noted that the input ports always use 24-bit PCM resolution and 16-bit compressed data word lengths. The output port of the CS492X provides 20-bit PCM resolution.

I²S: Figure 35 shows the I²S format. For I²S, data is presented most significant bit first, one SCLK delay after the transition of LRCLK and is valid on the rising edge of SCLK. For the I²S format, the left subframe is presented when LRCLK is low and the right subframe is presented when LRCLK is high. SCLK is expected to run at a frequency of 48Fs or greater on the input ports.

Left Justified: Figure 36 shows the left justified format. Data is presented most significant bit first

on the first SCLK after an LRCLK transition and is valid on the rising edge of SCLK. For the left justified format, the left subframe is presented when LRCLK is high and the right subframe is presented when LRCLK is low. SCLK is expected to run at a frequency of 48Fs or greater on the input ports.

Multi-Channel: Figure 37 shows the multi-channel format. In this format up to 6 channels of audio are presented on one data line with 20 bits per channel. Channels 0, 2, and 4 are presented while the LRCLK is high and channels 1, 3, 5 are presented while the LRCLK is low. Data is valid on the rising edge of SCLK and is presented most significant bit first.

Bursty: Bursty audio delivery is a special format in which only clock and data are used to deliver compressed data to the CS492X (i.e. no frame clock or LRCLK). A third line is used as a request to the host for more data. It is an indicator that the CS492X internal FIFO is low on data and can accept another block of data. Typically this mode is used for compressed data delivery where asynchronous data transfer occurs in the system, i.e. in a system such as a Set Top Box or HDTV. PCM data can not be presented in this mode since data is interpreted as a continuous stream with no word boundaries. For this reason bursty mode covers both data format and data type.

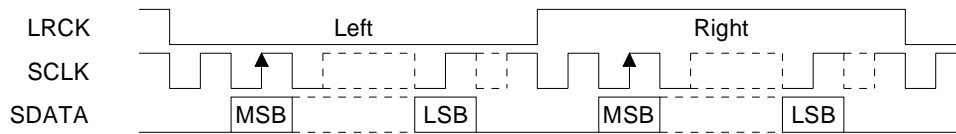

Figure 35. I²S Format

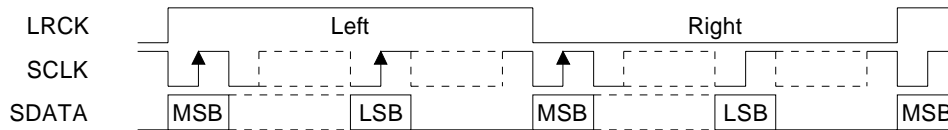

Figure 36. Left Justified Format

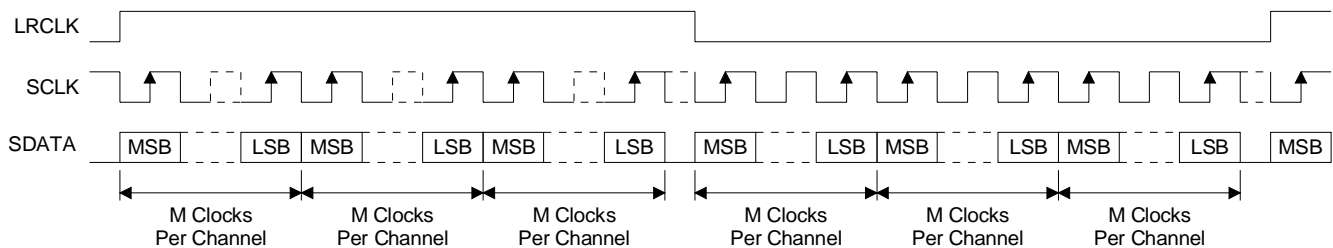

Figure 37. Multi-Channel Format
(M == 20)

5.2.2 Digital Input and Output Ports

Digital Audio Input or DAI port: Table 13 shows the three pins associated with the DAI port. LRCLKN1 is the frame clock which frames the incoming data. It is synonymous with LRCLK in the digital audio format figures. SCLKN1 is the bit clock which clocks in the data and is synonymous with SCLK in the digital audio format figures. SDATAN1 is the serial data input and is synonymous with SDATA in the digital audio format figures. This port operates as a slave. In the slave mode both SCLKN1 and LRCLKN1 are driven from an external source. This port can take either compressed data or PCM data but it will not operate in the Bursty data format.

Pin Name	Pin Number
LRCLKN1	26
SCLKN1	25
SDATAN1	22

Table 13. DAI - Digital Audio Input Port

Compressed Data Input or CDI port: Table 14 shows the three pins associated with the CDI port. The pins have different functions depending on how the port is configured. When configured for I²S, left justified or multi-channel, LRCLKN2 is the frame clock synonymous with LRCLK, SCLKN2 is the bit clock synonymous with SCLK, and SDATAN2 is the serial data input synonymous with SDATA. This port operates as a slave. In the slave mode both SCLKN2 and LRCLKN2 are driven from an external source. This port can take either compressed data or PCM data.

Pin Name	Pin Number
LRCLKN2, CMPREQ	29
SCLKN2, CMPCLK	28
SDATAN2, CMPDAT	27

Table 14. CDI - Compressed Digital Input Port

When the CDI is configured to operate in the Bursty format, CMPREQ is an output from the CS492X. When CMPREQ goes low it indicates

that the internal FIFO in the CS492X can accept a block of data. The block size is defined in the hardware configuration message section. This pin could be used as an interrupt request to a host controlling data flow or as a throttle for an external FIFO. CMPCLK is the bit clock that will clock in data on its rising edge and CMPDAT is the serial data input. It should be noted that CMPCLK must be gated when valid data is not present as CMPCLK will clock in data on its rising edge whether CMPREQ is high or low.

Digital Audio Output or DAO port: Table 15 shows the six lines associated with the DAO port. MCLK is the master clock which can be used to synchronize data flow throughout the system. MCLK is an input. LRCLK is the frame clock which frames the outgoing data and SCLK is the bit clock which clocks out the data. AUDATA0, AUDATA1, and AUDATA2 are the PCM audio outputs from the chip. Data is valid on the rising edge of SCLK. Table 16 shows the default mapping of data on the AUDATA[2:0] lines. This default can be changed using the DAO channel messages discussed in the Audio Manager portion of the each Application Code User's guide.

Pin Name	Pin Number
MCLK	44
SCLK	43
LRCLK	42
AUDATA0	41
AUDATA1	40
AUDATA2	39

Table 15. DAO - Digital Audio Output Port

Data Channel	Output Name	Subframe	Signal
0	Left	Left	AUDATA0
1	Right	Right	AUDATA0
2	Left Surround	Left	AUDATA1
3	Right Surround	Right	AUDATA1
4	Center	Left	AUDATA2
5	Subwoofer	Right	AUDATA2

Table 16. Output Channel Mapping

The DAO can operate as a master or a slave. As a master, the DAO drives both LRCLK and SCLK. LRCLK and SCLK will be divided down from MCLK. When the DAO is configured in slave mode, LRCLK and SCLK are inputs. If the DAO is a slave, then MCLK is a don't care as an input. The DAO can also be configured to drive MCLK, LRCLK, and SCLK when the internal PLL is enabled.

5.2.3 *Parallel Delivery of Data*

This section covers parallel delivery of digital audio data. The low level read and write formats are identical to those discussed in Section 2.2 "Parallel Host Communication" -- page 17.

It should be noted that when switching between PCM and compressed data delivery using the parallel data delivery, a new download, soft reset or application restart must be sent along with a FIFO configuration message for the appropriate data type (along with any other required hardware configuration messages).

5.2.3.1 *PCM Data Write in Parallel Host Mode*

Writing to the PCM audio data register entails a slightly different protocol than when writing control information. The MFC bit in the Host Control Register is an indicator of the PCM FIFO level. The MFC bit remains low until the FIFO threshold has been reached.

The PCMRST bit of the CONTROL register provides absolute software/hardware synchronization by initializing the input channel to uniquely recognize the first write to the byte-wide PCMDATA port. Toggling PCMRST high and low informs the DSP that the next sample read from the PCMDATA port is the first sample of the left channel. In this fashion, the CS492X can translate successive byte writes into a variable number of channels with a variable PCM sample size. In the most simple case, the CS492X can receive stereo 8-bit PCM one

byte at a time with the internal DSP assigning the first 8-bit write (after PCMRST) to the left channel and the second 8-bit write to the right channel. For 24-bit PCM, it assigns the first three 8-bit writes (after PCMRST) to the left channel and the next three writes to the right channel. Before starting PCM transfer, or to initiate a new PCM transfer, the PCMRST bit must be toggled as described above to insure data integrity.

Data must be delivered to the CS492X in blocks of data. The block size is set through a hardware configuration message. Before each block is delivered, the host should check the MFC bit. If the MFC bit is low, then the host can deliver a block of data one byte at a time. If the MFC bit is high, no more data should be sent to the CS492X. Once the MFC bit has gone low again, the host may send another block of PCM audio data. The MFC bit is FIFO level sensitive. In other words, it may change during the transfer of a block. The host should complete the block transfer and ignore the MFC bit until the block transfer is complete.

The generic function 'Read_Byte_*()' is used in the following example as a generalized reference to either Read_Byte_MOT() or Read_Byte_INT(), and 'Write_Byte_*()' is a generic reference to Write_Byte_MOT() or Write_Byte_INT(). Figure 38 shows the sequence for writing one block of PCM data when the device is in parallel host mode.

The protocol presented in the flow diagram on the following page will now be described in detail.

- 1) The host first reads the Host Control Register (A[1:0] = 01b) in order to determine the state of the input FIFOs.
- 2) In order to determine whether the CS492X is ready to accept another block of data, the host must check the MFC bit of the Host Control Register (bit 4). If MFC is high, then the DSP is not prepared to accept a new block of data, and the host should poll the Host Control Register again. If MFC is low, then the host may write a

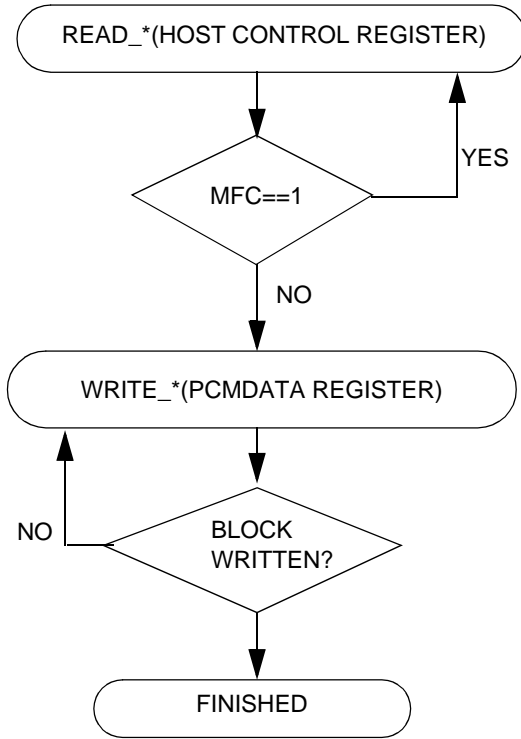

Figure 38. PCM Data Write Sequence in Parallel Host Mode Flow Diagram

block of PCM audio data to the PCMDATA register (A[1:0] = 10b) one byte at a time.

5.2.3.2 Compressed Data Write in Parallel Host Mode

Writing to the compressed data register is very similar to writing the PCM data register. Like PCM data transfers the host should check level of the Compressed Data FIFO before sending data, but the CS492X has two means of indicating the Compressed Data FIFO level. The MFB bit in the Host Control Register is one indicator of the Compressed Data FIFO level. The MFB bit remains low until the FIFO threshold has been reached. The alternative is to use the CMPREQ pin of the CS492X. The CMPREQ pin also remains low until the FIFO threshold has been reached. The host has the option of using either CMPREQ or the MFB bit.

Data must be delivered to the CS492X in blocks of data. Before each block is delivered, the host should check the MFB bit (or the CMPREQ pin). If the MFB bit (CMPREQ) is low, then the host can deliver a block of data one byte at a time. If the MFB bit (CMPREQ) is high, no more data should be sent to the CS492X. Once the MFB bit (CMPREQ) has gone low again, the host may send another block of compressed audio data.

One example is given for a system using the MFB bit, and one example has been given for systems using the CMPREQ pin. (Refer to figures 39 and 40 on the following pages).

The generic function 'Read_Byte_*()' is used in the following examples as a generalized reference to either Read_Byte_MOT() or Read_Byte_INT(), and 'Write_Byte_*()' is a generic reference to Write_Byte_MOT() or Write_Byte_INT().

5.2.3.2.1 MFB Bit Example

- 1) .The host first reads the Host Control Register (A[1:0] = 01b) in order to determine the state of the input FIFOs.
- 2) In order to determine whether the CS492X is ready to accept another block of data, the host must check the MFB bit of the Host Control Register (bit 4). If MFB is high, then the DSP is not prepared to accept a new block of data, and the host should poll the Host Control Register again. If MFB is low, then the host may write a block of compressed audio data to the CMP-DATA register (A[1:0] = 11b) one byte at a time.

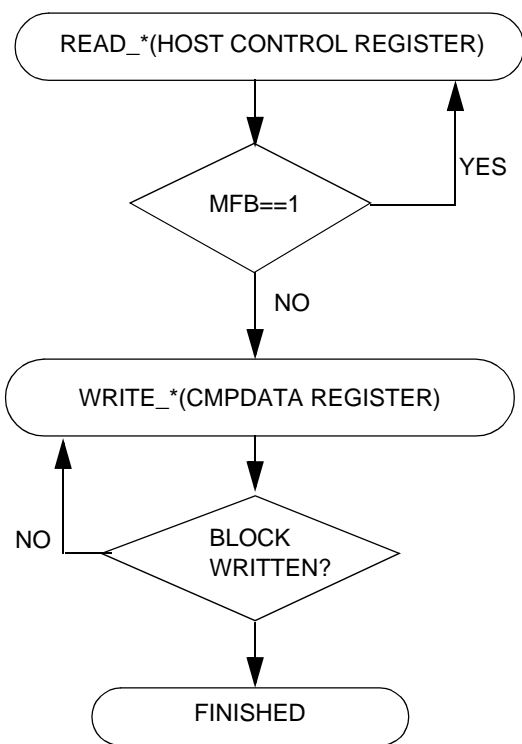

Figure 39. MFB Bit Status Polling Flow Diagram

5.2.3.2.2 CMPREQ Example

1) In order to determine whether the CS492X is ready to accept another block of data, the host can check the CMPREQ pin of the CS492X. If CMPREQ is high, then the DSP is not prepared to accept a new block of data, and the host should poll the CMPREQ again. If CMPREQ is low, then the host may write a block of compressed audio data to the CMPDATA register (A[1:0] = 11b) one byte at a time.

5.3 Configuration Messages

This section discusses the actual messages to be sent to the device after soft reset or download. To assemble the entire hardware configuration message, the hex messages for each individual parameter should be concatenated, creating one large message. If the default configuration for a parameter is acceptable, then no message needs to be sent.

5.3.1 Address Checking

The following 4-word hex message configures the address checking circuitry of the CS492X: It should be noted that this will allow the host to disable address checking or change the address of the device. If address checking enabled with an address of 0x00 is acceptable, then these messages do not need to be sent.

0x800252
 0x00FFFF
 0x800152
 0xHH0000

In the last word the following bits should replace **HH**:

bits23:17 - New Address to use for checking (if enabling address checking)

bit 16 - 1 = Address checking on
 0 = Address checking off

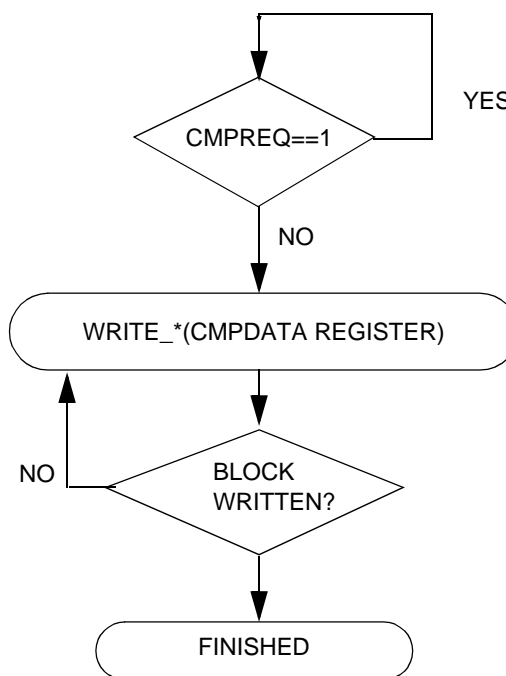

Figure 40. CMPREQ Pin Status Polling Flow Diagram

5.3.2 Input

Both data format (I²S, Left Justified, etc.) and data type (compressed or PCM) are required to fully define the input port's hardware configuration. The DAI and the CDI are configured by the same group of messages since their configurations are interrelated. The naming convention of the input hardware configuration is as follows:

INPUT A B C D

where A, B, C and D are the parameters used to fully define the input port. The parameters are defined as follows:

A - Data Type

B - Data Format (This is a don't care for parallel modes of data delivery)

C - SCLK Polarity

D - FIFO Setup (only valid for parallel modes of data delivery)

The following tables show the different values for each parameter as well as the hex message that needs to be sent. When creating the hardware configuration message, only one hex message should be sent per parameter. It should be noted that the entire B parameter hex message must be sent, even if one of the input ports has been defined as unused by the A parameter .

5.3.2.1 Special Considerations

- 1) 24-bit PCM input requires at least 24 SCLKS per sub-frame. The DSP always uses 24-bit resolution for PCM input. Systems having less than 24-bit resolution will not have a problem as the extra bits taken by the DSP will be under the noise floor of the input signal for left justified and I²S formats. For compressed input, data is always taken in 16 bit word lengths.
- 2) If the clocks to the audio ports are known to be corrupted, such as when an SPDIF receiver

A Value (note 1)	Data Type	Hex Message
0 (default)	DAI - PCM CDI - Compressed	0x800210 0x3FBFC0 0x800110 0x80002C
1	DAI - PCM and Compressed CDI - Unused	0x800210 0x3FBFC0 0x800110 0xC0002C
2	DAI - Unused CDI - PCM	0x800210 0x3FBFC0 0x800110 0x800020
3	DAI - PCM CDI - Bursty Compressed (See Special Considerations Note 2)	0x800210 0x003FC0 0x800110 0x0E002C
4	DAI - Multi-Channel PCM CDI - PCM	0x800210 0x3FBFC0 0x800110 0x80002C
5	DAI - PCM CDI - Multi-Channel PCM	0x800210 0x3FBFC0 0x800110 0x800025
6	DAI - PCM CDI - Not Used Parallel Port - Compressed (FIFO B)	0x800210 0x003FC0 0x800110 0x0E002B
7	DAI - Not Used CDI - PCM Parallel Port - Compressed (FIFO B)	0x800210 0x003FC0 0x800110 0x0E0023
8	DAI - Not Used CDI - Not Used Parallel Port - PCM (FIFO C) and Compressed (FIFO B)	0x800210 0x003FC0 0x800110 0x0E0013

Table 17. Input Data Type Configuration

goes out of lock, the device should be reset and reconfigured. Failure to do so could result in corrupted data and unpredictable behavior.

Any modes not listed are not supported by current software. If a certain mode is desired that is not available, please contact the factory about its availability.

B Value (note 1)	Data Format	Hex Message
0 (default)	PCM - I ² S 24 Bit Compressed - I ² S 16 Bit	0x800217 0x8080FF 0x80021A 0x8080FF 0x800117 0x011100 0x80011A 0x011900
1	PCM - Left Justified 24 Bit Compressed - Left Justified 16 Bit	0x800217 0x8080FF 0x80021A 0x8080FF 0x800117 0x001000 0x80011A 0x001800
2	PCM - I2S 24 Bit Multi-channel PCM - Left Justified 24 bit PCM	0x800217 0x8080FF 0x80021A 0x8080FF 0x800117 0x0048C0 0x80011A 0x0119C0
3	PCM - Left Justified 24 Bit Multi-channel PCM - Left Justified 24 bit	0x800217 0x8080FF 0x80021A 0x8080FF 0x800117 0x0048C0 0x80011A 0x0018C0
4-6	Not Used	
7	PCM - I2S 24 Bit Multi-channel PCM - Left Justified 20 bit	0x800217 0x8080FF 0x80021A 0x8080FF 0x800117 0x003CC0 0x80011A 0x0119C0
8	PCM - Left Justified 24 Bit Multi-channel PCM - Left Justified 20 bit	0x800217 0x8080FF 0x80021A 0x8080FF 0x800117 0x003CC0 0x80011A 0x0018C0

Table 18. Input Data Format Configuration

C Value (note 1)	SCLK Polarity (Both CDI & DAI Port)	Hex Message
0 (default)	Data Clocked in on Rising Edge	0x800217 0xFFFFDF 0x80021A 0xFFFFDF
1	Data Clocked in on Falling Edge	0x800117 0x000020 0x80011A 0x000020

Table 19. Input SCLK Polarity Configuration

D Value	FIFO Size & Blocksize (no default - only applicable to parallel delivery modes)	Hex Message
1	Compressed FIFO B Size - 6kbyte Blocksize - 2kbyte	0x800014 0x280D00
2	PCM FIFO C Size - 6kbyte Blocksize - 2kbyte	0x800014 0x820300

Table 20. FIFO Setup Configuration

5.3.3 Output

The naming convention for the DAO configuration is as follows:

OUTPUT A B C D E

where the parameters are defined as:

A - DAO Mode (Master/Slave for LRCLK and SCLK)

B - Data Format

C - MCLK Frequency

D - SCLK Frequency

E - SCLK Polarity

The following tables show the different values for each parameter as well as the hex message that needs to be sent. When creating the hardware configuration message, only one hex message should be sent per parameter.

A Value	DAO Modes (LRCLK & SCLK)	Hex Message
0 (default)	MCLK - Slave SCLK - Slave LRCLK - Slave	0x80017F 0x400000
1	MCLK - Slave SCLK - Master LRCLK - Master	0x80027F 0xBFFFFFFF
2	MCLK - Master SCLK - Master LRCLK - Master	0x80027F 0xBFDFFF

Table 21. Output Clock Configuration

5.3.3.1 Special Considerations

- 1) All PCM output is 20-bit resolution
- 2) An SCLK frequency of at least 128Fs must be selected for the 20-bit multi-channel mode.
- 3) An SCLK frequency of at least 256Fs must be selected for the 24-bit multi-channel mode.
- 4) If the clocks to the audio ports are known to be corrupted, such as when an SPDIF receiver goes out of lock, the device should be reset and

B Value (Note 3)	DAO Data Format	Hex Message
0 (default)	I ² S 20-bit	0x80027F 0xFC7FFF 0x80027C 0xF01F00 0x80027D 0xF01F00 0x80027E 0xF01F00 0x80017F 0x038000 0x80017C 0x000001 0x80017D 0x000001 0x80017E 0x000001
1	Left Justified 20-bit	0x80027F 0xFC7FFF 0x80027C 0xF01F00 0x80027D 0xF01F00 0x80027E 0xF01F00 0x80017F 0x018000
2	Multi-Channel 20 bit Left Justified (SCLK must be at least 128Fs for this mode)	0x80027F 0xFC7FFF 0x80027C 0xF01F00 0x80027D 0xF01F00 0x80027E 0xF01F00
3	Multi-Channel 24 bit Left Justified (SCLK must be at least 256Fs for this mode)	0x80027F 0xFC7FFF 0x80027C 0xF01F00 0x80027D 0xF01F00 0x80027E 0xF01F00 0x80017C 0x008000

Table 22. Output Data Format Configuration

reconfigured. Failure to do so could result in corrupted data and unpredictable behavior.

C Value	Output MCLK Frequency	Hex Message
0 (default)	256Fs	0x80027F 0xFFE7FF
1	512Fs	0x80027F 0xFFE7FF 0x80017F 0x001000
2	128Fs	0x80027F 0xFFE7FF 0x80017F 0x001800
3	384Fs (SCLK must be 64Fs in this mode)	0x80027F 0xFFE7FF 0x80017F 0x000800

Table 23. Output MCLK Configuration

D Value	Output SCLK Frequency	Hex Message
0 (default)	64Fs	0x80027F 0xFFF8FF 0x80017F 0x000100
1	128Fs	0x80027F 0xFFF8FF 0x80017F 0x000200
2	256Fs	0x80027F 0xFFF8FF 0x80017F 0x000300

Table 24. Output SCLK Configuration

E Value	Output SCLK Polarity	Hex Message
0 (default)	Data Valid on Rising Edge (clocked out on falling)	0x80027F 0xF7FFFF
1	Data Valid on Falling Edge (clocked out on rising)	0x80017F 0x080000

Table 25. Output SCLK Polarity Configuration

5.3.4 Creating Hardware Configuration Messages

The single hardware configuration message that must be sent to the CS492X after download or soft reset should be a concatenation of the messages in the Section 5.3.1 through Section 5.3.3. The complete hardware configuration message should be created by taking a message for each parameter

(where the default is not acceptable) and concatenating the messages together. No messages need to be sent if the default configuration for a particular parameter is acceptable. This example can be easily expanded to fit other system requirements.

For example if the host system has the following configuration:

Address Checking: Enabled with an address of 0000000b

The above configuration is default so no configuration message is required.

DAI: Left Justified Slave Mode
PCM and Compressed data

CDI: Not used

The above configuration corresponds to
INPUT 1 1

which corresponds to a configuration message of:

```
0x800210
0x3FBFC0
0x800110
0xC0002C
0x800217
0x8080FF
0x80021A
0x8080FF
0x800117
0x001000
0x80011A
0x001800
```

DAO: Left Justified slave mode (LRCLK, SCLK inputs)
MCLK @ 256Fs
SCLK @ 64Fs

The above configuration corresponds to
OUTPUT 0 1 0 0

which has a configuration message of:

0x80027F
0xFC7FFF
0x80027C
0xF01F00
0x80027D
0xF01F00
0x80027E
0xF01F00
0x80017F
0x018000

Concatenating the messages together gives the following hardware configuration message that should be sent after download or soft reset:

WORD#	VALUE
1	0x800210
2	0x3FBFC0
3	0x800110
4	0xC0002C
5	0x800217
6	0x8080FF
7	0x80021A
8	0x8080FF
9	0x800117
10	0x001000
11	0x80011A
12	0x001800
13	0x80027F
14	0xFC7FFF
15	0x80027C
16	0xF01F00
17	0x80027D
18	0xF01F00
19	0x80027E
20	0xF01F00
21	0x80017F
22	0x018000

Table 26. Example Values to be Sent to CS492X After Download or Soft Reset

6. APPENDIX A - PSEUDOCODE FOR THE CS4923/4/5/6/7/8/9 FAMILY

In the pseudocode, it is assumed a function call to a signal name forces the signal HIGH or LOW (i.e. *CS(LOW)* forces the chip select line of the CS492X LOW). Also, the function *Read(SIGNAL)* returns the value of *SIGNAL*. The pseudocode that is not communication specific uses function calls to *Write_** and *Read_**. The * should be replaced by the communication mode for the system.

6.1 SPI Pseudocode

6.1.1 SPI Write Operation

```
#define ADDR23 0x00
#define WRITE 0xFE

unsigned char message[size];

void Write_SPI(unsigned char *message, int size) /* size=message length in bytes */
{
    int x;

    CS(LOW);

    Write_Byte_SPI(ADDR4923 & WRITE);

    for(x=0;x<size;x++)
        Write_Byte_SPI(message[x]);

    CS(HIGH);
} /* Write_SPI */

void Write_Byte_SPI(unsigned char data_byte)
{
    char bit_number;

    for (bit_number=7;bit_number>=0;bit_number--)
    {
        if((data_byte>>bit_number)&0x01) /* check each bit to write */
            CDIN(HIGH);
        else
            CDIN(LOW);

        SCL(HIGH); /* clock in the bit */

        SCL(LOW); /* insure data byte is clocked in to CS4923/4/5/6/7/8/9 */
    }
} /*Write_Byte_SPI */
```

6.1.2 SPI Read Operation

```
#define ADDR23 0x00
#define READ 0x01

unsigned char data_byte_array[size];

void Read_SPI(unsigned char *data_byte_array)
{
    int i = 0;
    char not_end_of_read = 1;

    CS23(LOW);

    Write_Byte_SPI(ADDR4923 | READ);

    while (not_end_of_read)
    {
        not_end_of_read = Read_Byte_SPI(data_byte_array + i);
        printf("%02x ", data_byte_array[i]);
        i++;
    }

    CS23(HIGH);
} /* SPI_Read */

unsigned char Read_Byte_SPI(unsigned char *DataIn)
{
    int bit_number;
    int end_of_data = 1;

    *DataIn=0;

    for (bit_number=0; bit_number<8; bit_number++)
    {
        SCL(HIGH);          /*clock out data */

        if (bit_number == 6)
            if (Read(/INTREQ) == 1)/*check request */
                end_of_data = 0; /*if HIGH -> no more data, if LOW -> read again */

        *DataIn |= Read(CDOUT) << bit_number;

        SCL(LOW);
    }

    return(end_of_data);
} /*Read_Byte_SPI */
```

6.2 I²C Pseudocode

6.2.1 I²C Write Operation

```
#define ADDR23 0x00
#define WRITE 0xFE

unsigned char message[size];

void Write_I2C(unsigned char *message, int size) /* size=message length in bytes */
{
    int x;

    Send_I2C_Start();

    if(Write_Byte_I2C(ADDR4923 & WRITE))
    {
        /* Received NACK so resend address */

        if(Write_Byte_I2C(ADDR4923 & WRITE))
        {
            /*Second NACK so send stop condition and return ERROR*/
            printf("\n error sending address byte");
            Send_I2C_Stop();
            return ERROR;
        }
    }

    for(x=0;x<size;x++)
    {
        if(Write_Byte_I2C(message[x]))
        {
            /*Received NACK so resend data byte */

            if(Write_Byte_I2C(message[x]))
            {
                /*Second NACK so send stop condition and return ERROR*/
                printf("\n error sending byte %d", x);
                Send_I2C_Stop();
                return ERROR;
            }
        }
    }

    Send_I2C_Stop();

    return 0;
}/*Write_I2C*/

void Send_I2C_Start()
{
    /* This function assumes that SCCLK and SCDIO are both HIGH when called */

    SCDIO(LOW);/* drive SCDIO LOW while SCCLK is HIGH for start condition */
    SCCLK(LOW);/* drive SCCLK LOW to prepare for data transfer */
}

void Send_I2C_Stop()
{
    SCDIO(LOW); /* make sure SCDIO is LOW */
    SCCLK(HIGH);/* drive SCCLK HIGH */
    SCDIO(HIGH);/* drive SCDIO for the STOP condition */
}

unsigned char Write_Byte_I2C(unsigned char data)
{
```

```
int bit_number;
for (bit_number=7;bit_number>=0;bit_number--)
{
    if((data>>bit_number)&0x01) /* check each bit to write and drive data line */
        SCDIO(HIGH);
    else
        SCDIO(LOW);

    SCCLK(HIGH);      /*clock in data */
    SCCLK(LOW);
}

SCDIO(HIGH);      /*release bus so 4923 can ACK*/
return Get_ACK(); /* return value of ACK*/
}

unsigned char Get_ACK()
{
    unsigned char ack;

    SCCLK(HIGH);/* latch the ACK */
    ack = Read(SCDIO); /*Read ACK*/
    SCCLK(LOW);
    return(ack);
}
```

6.2.2 I²C Read Operation

```
#define ADDR23 0x00
#define READ 0x01

unsigned char data_byte_array[size];

char Read_I2C(unsigned char *data_byte_array)
{
    int i = 0;

    char not_end_of_read = 1;

    Send_I2C_Start();

    if(Write_Byte_I2C(ADDR4923 | READ))
    {
        /*Received NACK so send again */

        if(Write_Byte_I2C(ADDR4923 | READ))
        {
            /*Second NACK so send stop condition and return ERROR*/
            printf("\n error sending address byte for read condition");
            Send_I2C_Stop();
            return ERROR;
        }
    }

    while (not_end_of_read)
    {
        not_end_of_read = Read_Byte_I2C(data_byte_array + i);
        printf("%02x ", data_byte_array[i]);
        i++;
    }

    Send_I2C_Stop();

    return(0);
}

unsigned char Read_Byte_I2C(unsigned char *DataIn)
{
    int bit_number;

    int end_of_data = 0;

    *DataIn=0;

    for (bit_number=0; bit_number<8; bit_number++)
    {
        SCL(HIGH);

        if (bit_number == 7)
            if (Read(/INTREQ)) /* check request */
                end_of_data = 1; /* if HIGH -> no more data, if LOW -> read again */

        *DataIn |= Read(CDOUT) << bit_number

        SCL(LOW);
    }

    if (end_of_data)
    {
        Send_NACK();
        return 0;
    }
    else
```

```
    {
        Send_ACK();
        return 1;
    }
}

void Send_ACK()
{
    SCGIO(LOW); /* force SCGIO LOW to ACK */
    SCCLK(HIGH); /* clock the ACK */
    SCCLK(LOW);
}

void Send_NACK()
{
    SCGIO(HIGH); /* release SCGIO HIGH to NACK */
    SCCLK(HIGH); /* clock the NACK */
    SCCLK(LOW);
}
```

6.3 Typical Download Session with the CS4923/4/5/6/7/8/9

```
#define BOOT_MSG_SIZE 3
void Boot_CS4923()
{
    unsigned char error = 0;
    unsigned char message_bytes[3];

    RESET(LOW); /* hard reset the CS4923/4/5/6/7/8/9 */

    RESET(HIGH);

    Write_*(DOWNLOAD_BOOT, BOOT_MSG_SIZE);

    while(Read(/INTREQ)); /* wait for /INTREQ to fall */

    Read_*(message_bytes); /* read CS4923/4/5/6/7/8/9 response */

    switch(message_bytes[0])
    {
        case 0x01:
            printf("\n BOOT_START ");
            error = 0;
            break;
        case 0xfa:
        case 0xfc:
            printf("\n BOOT_ERROR ");
            error = 1;
            break;
        case 0xfb:
            printf("\n INVALID_MSG ");
            error = 1;
            break;
        case 0xfd:
        case 0xfe:
            printf("\n INIT_FAILURE ");
            error = 1;
            break;
        default:
            printf("\n UNRECOGNIZED BYTE ");
            error = 1;
            break;
    }

    if(error)
        exit();

    Write_*(.LD_FILE_IMAGE_POINTER, .LD_FILE_IMAGE_SIZE);

    while(Read(/INTREQ)); /* wait for /INTREQ to fall */

    Read_*(message_bytes); /* read CS4923/4/5/6/7/8/9 response */

    switch(message_bytes[0])
    {
        case 0x02:
            printf("\n BOOT_SUCCESS ");
            error=0;
            break;
        case 0xff:
            printf("\n BAD_CHECKSUM ");
            error = 1;
            break;
        default:
            printf("\n UNRECOGNIZED BYTE AFTER DOWNLOAD");
            error = 1;
            break;
    }
}
```



```
    if(error)
        exit();

    Write_*(BOOT_SUCCESS_RECEIVED, BOOT_MSG_SIZE);
}/* Boot_CS4923/4/5/6/7/8/9 */
```

6.4 Typical Reset Sequence for the CS4923/4/5/6/7/8/9

```
void Reset_CS492X()
{
    RESET(LOW);
    RESET(HIGH);
    Write_*(SOFTRESET, BOOT_MSG_SIZE);
    Delay(1); /* Insure 1 ms pause before sending configuration messages */
    Write_*(Configuration_Messages, Message Size)
}
```

SMART
Analog™