

CrystalClear™ AC '97 Six Channel CNR Audio Reference Design

Features

- Six Channel Analog Audio Output
 - Two Channels on the Motherboard
 - Four Channels on the CRD4201-1S
- CS4201 audio codec and CS4334 DAC
- 20-bit D to A conversion (DAC)
- 18-bit A to D conversion (ADC)
- S/PDIF (IEC-958) optical digital output
- Complete suite of Analog I/O connections:
 - Line, Mic, CD, Video, and Aux Inputs
 - Center, Sub-Woofer, and Rear Channel Outputs
- 2-layer low cost PC board
- Meets Intel[®] AC '97 version 2.1 specification
- Exceeds Microsoft's[®] PC 2001 audio performance requirements.

Description

The CRD4201-1S Communication and Networking Riser (CNR) reference design features four channel analog audio outputs and an optical S/PDIF digital output. This board is designed to provide the rear left, rear right, center, and sub-woofer channels in a six channel audio sub-system. The front left and right channels are provided by the primary audio codec on the motherboard. This board uses the CS4201 configured as a secondary audio codec. It has several advanced features such as serial digital audio output and up to 30 dB of microphone boost.

The CRD4201-1S reference design is available by ordering the *CMK4201-1* manufacturing kit. This kit includes the CRD4201-1, the CRD4201-1S, a full set of schematic design files (OrCAD[®] format), PCB job files (PADS[®] ASCII), PCB artwork files, and bill of materials. This reference design offers significant cost savings over competing solutions and can be easily modified to meet your specific design goals.

ORDERING INFO

CMK4201-1 (Manufacturing Kit)

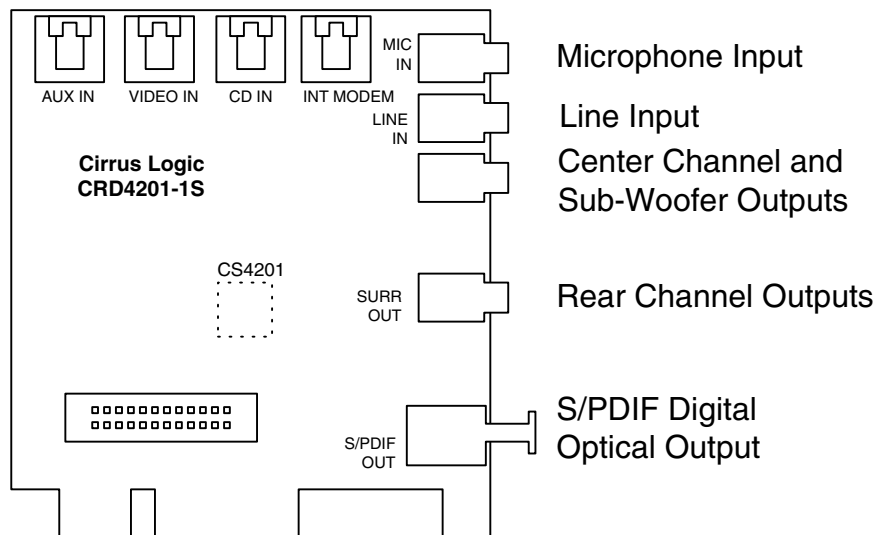

Preliminary Product Information

This document contains information for a new product. Cirrus Logic reserves the right to modify this product without notice.

TABLE OF CONTENTS

1. GENERAL INFORMATION	3
2. SCHEMATIC DESCRIPTION	3
2.1 CS4201 Audio Codec	3
2.2 Analog Inputs	4
2.3 Rear Channel Outputs	4
2.4 Center and Sub-Woofer Outputs	4
2.5 S/PDIF Optical Output	4
2.6 CNR Connector and EEPROM	4
2.7 Component Selection	4
2.8 EMI Components	5
3. GROUNDING AND LAYOUT	5
3.1 Partitioned Voltage and Ground Planes	5
3.2 CS4201 Layout Notes	5
4. REFERENCES	6
4.1 ADDENDUM	6
5. BILL OF MATERIALS	19

LIST OF FIGURES

Figure 1. Block Diagram	7
Figure 2. CS4201 Audio Codec	8
Figure 3. Analog Inputs	9
Figure 4. Rear Channel Outputs	10
Figure 5. Center Channel and Sub-Woofer Outputs	11
Figure 6. S/PDIF Optical Output	12
Figure 7. CNR Connector	13
Figure 8. PCB Layout: Top Assembly Drawing	14
Figure 9. PCB Layout: Top Layer	15
Figure 10. PCB Layout: Bottom Layer	16
Figure 11. PCB Layout: Bottom Assembly	17
Figure 12. PCB Layout: Top Silkscreen	18

Contacting Cirrus Logic Support

For a complete listing of Direct Sales, Distributor, and Sales Representative contacts, visit the Cirrus Logic web site at:
<http://www.cirrus.com/corporate/contacts/>

Microsoft , Windows 95, Windows 98 and Windows Millennium and WHQL is registered trademark of Microsoft.
CrystalClear is a trademark of Cirrus Logic, Inc.
Intel is a registered trademark of Intel Corporation.
OrCAD is a registered trademark of OrCAD, Inc.
PADS is a registered trademark of, PADS Software, Inc.

Preliminary product information describes products which are in production, but for which full characterization data is not yet available. Advance product information describes products which are in development and subject to development changes. Cirrus Logic, Inc. has made best efforts to ensure that the information contained in this document is accurate and reliable. However, the information is subject to change without notice and is provided "AS IS" without warranty of any kind (express or implied). No responsibility is assumed by Cirrus Logic, Inc. for the use of this information, nor for infringements of patents or other rights of third parties. This document is the property of Cirrus Logic, Inc. and implies no license under patents, copyrights, trademarks, or trade secrets. No part of this publication may be copied, reproduced, stored in a retrieval system, or transmitted, in any form or by any means (electronic, mechanical, photographic, or otherwise) without the prior written consent of Cirrus Logic, Inc. Items from any Cirrus Logic website or disk may be printed for use by the user. However, no part of the printout or electronic files may be copied, reproduced, stored in a retrieval system, or transmitted, in any form or by any means (electronic, mechanical, photographic, or otherwise) without the prior written consent of Cirrus Logic, Inc. Furthermore, no part of this publication may be used as a basis for manufacture or sale of any items without the prior written consent of Cirrus Logic, Inc. The names of products of Cirrus Logic, Inc. or other vendors and suppliers appearing in this document may be trademarks or service marks of their respective owners which may be registered in some jurisdictions. A list of Cirrus Logic, Inc. trademarks and service marks can be found at <http://www.cirrus.com>.

1. GENERAL INFORMATION

The CRD4201-1S reference design is a CNR card that features four channel CD quality analog audio outputs. Combined with a CS4201 audio codec on the motherboard, the CRD4201-1S forms the rear left, rear right, center, and sub-woofer outputs of a six channel PC audio sub-system. The card includes a CS4201 AC '97 audio codec and a CS4334 24-bit serial stereo DAC. This combination gives the CRD4201-1S a rich feature set and industry leading audio performance.

The CS4201 on this card is configured as the secondary AC '97 audio codec. This board must be used in conjunction with a CS4201 audio codec on the motherboard. For applications requiring a complete six channel audio subsystem on a single CNR card, use the CRD4201-1 also included in the CMK4201-1 manufacturing kit.

The CS4201 audio codec has a stereo 20-bit DAC providing 2 channels of audio output, a stereo 18-bit ADC, and a very flexible analog audio mixer. A CS4334 DAC is connected to the CS4201 serial output to provide two additional channels of analog audio. The CS4201 also features three stereo pairs of line level analog inputs, a microphone input, and a stereo pseudo-differential CD input. The input signals can be routed to the ADC for recording or mixed together for recording and direct playback. The CS4201 has internal registers that are used to control its various features such as volume levels, audio muting, and signal routing. The CS4201 maintains high audio quality and exceeds the Microsoft[®] PC-2001 audio performance specification.

The CS4201 audio codec communicates to the audio controller across the CNR interface through the AC-Link. The AC-Link is a 5-wire serial digital interface that transfers digital audio between the two devices and also sends commands from the audio controller to the CS4201's registers. For more information on the AC-Link, see the Intel[®] AC'97 version 2.1 specification.

2. SCHEMATIC DESCRIPTION

The block diagram in Figure 1 illustrates the interconnections between the various schematic pages found at the end of this document. Sections 2.1 through 2.8 describe the circuitry contained in these schematics. Note: this design is based on the CRD4201-1 six channel reference design with some population option changes.

2.1 CS4201 Audio Codec

The CS4201 audio codec is shown in Figure 2. The input signals to the CS4201 originate from the analog inputs in Figure 3, and the analog outputs are shown in Figure 5. AFLT1 and AFLT2 (pins 29, 30) require 1000 pF NPO/COG capacitors connected to analog ground. These capacitors provide a single pole lowpass filter at the inputs of the ADC. No other input filtering is required.

FLT3D, FLTI, and FLTO (pins 32, 33, 34) form the internal analog 3D enhancement filter. The FLT3D pin requires a 0.01 μ F capacitor to analog ground. The FLT0 and FLT1 pins require a NPO/COG 1000 pF series capacitor.

The AC-Link may require series termination resistors to prevent reflections. These are normally placed as close as possible to the transmitting end of a particular AC-Link signal. The SDATA_IN (pin 8) output of the CS4201 has a 47 Ω series termination resistor.

The CS4201 is powered by separate analog and digital power supplies, each with their own respective grounds. The AGND symbols refer to analog ground, and DGND symbols refer to digital ground. Each power pin needs separate decoupling capacitors. The CS4201 audio codec uses a 0.1 μ F ceramic capacitor for each of the 3.3 V digital and 5 V analog supply pins. These decoupling capacitors are placed as close as possible to their respective pins.

2.2 Analog Inputs

The LINE_IN, VIDEO_IN, and AUX_IN stereo input jacks in Figure 3 are connected to a 6 dB voltage divider and AC coupled to the CS4201. The voltage divider allows input signal levels of up to 2 Vrms. The 2.2 μ F AC coupling capacitor values are used to minimize low frequency roll-off.

The microphone circuit is AC coupled by a 1 μ F capacitor to minimize low frequency roll-off. The microphone circuit provides low voltage phantom power for electret microphones. Phantom power is derived from the +5 V analog supply and provides a maximum of 4.2 V under no load and a minimum of 2.0 V under a 0.8 mA load. These parameters are required by PC-99 and PC-2001.

The CS4201 features a pseudo-differential CD input that minimizes common mode noise and interference. Each CD signal acts as one side of the differential input and CD_COM acts as the other side. CD_COM is used as the common return path for both the left and right channels.

2.3 Rear Channel Outputs

The outputs in Figure 4 drive the rear left and right speakers. These outputs are driven digitally from the CS4201 through a serial output port and converted to analog audio through a high-performance CS4334 24-bit stereo DAC.

2.4 Center and Sub-Woofer Outputs

Figure 5 details the center and sub-woofer outputs. These signals originate from the Line Output pins of the CS4201 (center channel on pin 35 and sub-woofer on pin 36.) These signals are buffered by a Motorola MC34072 dual op-amp. The MC34072 is a high performance low noise op-amp well suited for audio applications. These outputs are designed to drive high impedance loads of 10 K Ω or higher.

2.5 S/PDIF Optical Output

The S/PDIF (IEC-958) digital output shown in Figure 6 is compatible with digital outputs on consumer devices such as Mini Disk recorders and consumer stereo receivers. The S/PDIF output operates at a fixed sampling frequency of 48 KHz. It uses an industry standard TOSLINK digital optical transmitter, the Toshiba TOTX-173.

2.6 CNR Connector and EEPROM

The Communications and Networking Riser interface (CNR) is shown in Figure 7. CNR is a motherboard interface that supports audio, modem, and LAN subsystems. CNR applications are targeted at OEMs, system manufacturers, and system integrators who wish to take advantage of physically separating their audio, modem, or LAN circuitry from the PC motherboard. CNR accomplishes this without the additional cost associated with the interface circuitry required for a PCI bus add-in card.

The CRD4201-1S uses the AC-Link, SMBus and power. The SMBus is used to provide Plug-and-Play functionality for the CNR card. The SMBus signals are connected to a AT24C02 EEPROM. The EEPROM holds the Subsystem Vendor ID and Subsystem ID. It also contains other information for implementing a plug-and-play CNR card. For CNR design specifications, programming utilities, and information on programming the EEPROM see the Intel[®] Communication and Network Riser (CNR) homepage at <http://developer.intel.com/technology/cnr/>.

2.7 Component Selection

Great attention was given to the particular components used on the CRD4201-1S board with cost, performance, and package selection as the most important factors. Listed are some of the guidelines used in the selection of components:

- No components smaller than 0805 SMT package.

- Only single package passive components. No resistor packs. This reduces the risk of crosstalk between analog audio signals.
- All components except connectors and jumpers are in surface mount packages.

2.8 EMI Components

Optional capacitors and inductors are included to help the board meet EMI compliance tests, such as FCC Part 15. Choose these component values according to individual requirements.

3. GROUNDING AND LAYOUT

The component layout and signal routing of the CRD4201-1S provides a good model for laying out your own CNR add-in card.

3.1 Partitioned Voltage and Ground Planes

It is critical for good audio performance to separate digital and analog sections to prevent digital noise from affecting the performance of the analog circuits. The analog section of the CRD4201-1S is completely isolated from the digital section with a 100 mil partition. Partitioning is defined as the absence of copper on all signal layers. The analog and digital sections each have their own separate ground planes. All analog components, power traces, and signal traces are routed over the analog ground plane. Digital components, power traces and signal traces are not allowed to crossover into the analog section.

The CS4201 audio codec is placed at the transition point between the analog and digital ground planes.

The pins are arranged on the CS4201 so that the analog and digital signals are separated from each other. *The analog and digital ground planes must be tied together for the CS4201 to maintain proper voltage references.* For best results, the two ground planes are tied together with a single 50 mil trace under the CS4201 near its digital ground pins.

A separate chassis ground provides a noise-free reference point for all of the EMI suppression components. The chassis ground plane is connected to the analog ground plane at the external jacks.

3.2 CS4201 Layout Notes

Refer to the *CS4201 Data Sheet* for analog and digital partitioning guidelines and bypass capacitor placement. Pay special attention to the bypass capacitors on REFFLT, AFLT1, AFLT2 and the power supply capacitors.

Schematic & Layout Review Service

Confirm Optimum
Schematic & Layout
Before Building Your Board.

For Our Free Review Service
Call Applications Engineering.

C a l l : (5 1 2) 4 4 5 - 7 2 2 2



4. REFERENCES

- 1) Intel[®], Audio Codec '97 Component Specification, Revision 2.1, May 22, 1998.
<http://developer.intel.com/>
- 2) Intel[®], CNR Specification 1.0
<http://developer.intel.com/technology/cnr/index.htm>
- 3) Cirrus Logic, CS4201 Audio Codec '97 Data Sheet
<http://www.cirrus.com/products>
- 4) Steve Harris, Clif Sanchez, Personal Computer Audio Quality Measurements, Ver 1.0
<http://www.cirrus.com/pubs/meas100.pdf>
- 5) Microsoft, PC Design Guidelines,
<http://www.microsoft.com/hwdev/desguid/>
- 6) M. Montrose. Printed Circuit Board Design Techniques for EMC Compliance, IEEE Press, New York: 1996.

4.1 ADDENDUM

- Schematic drawings
- Layout drawings
- Bill of materials

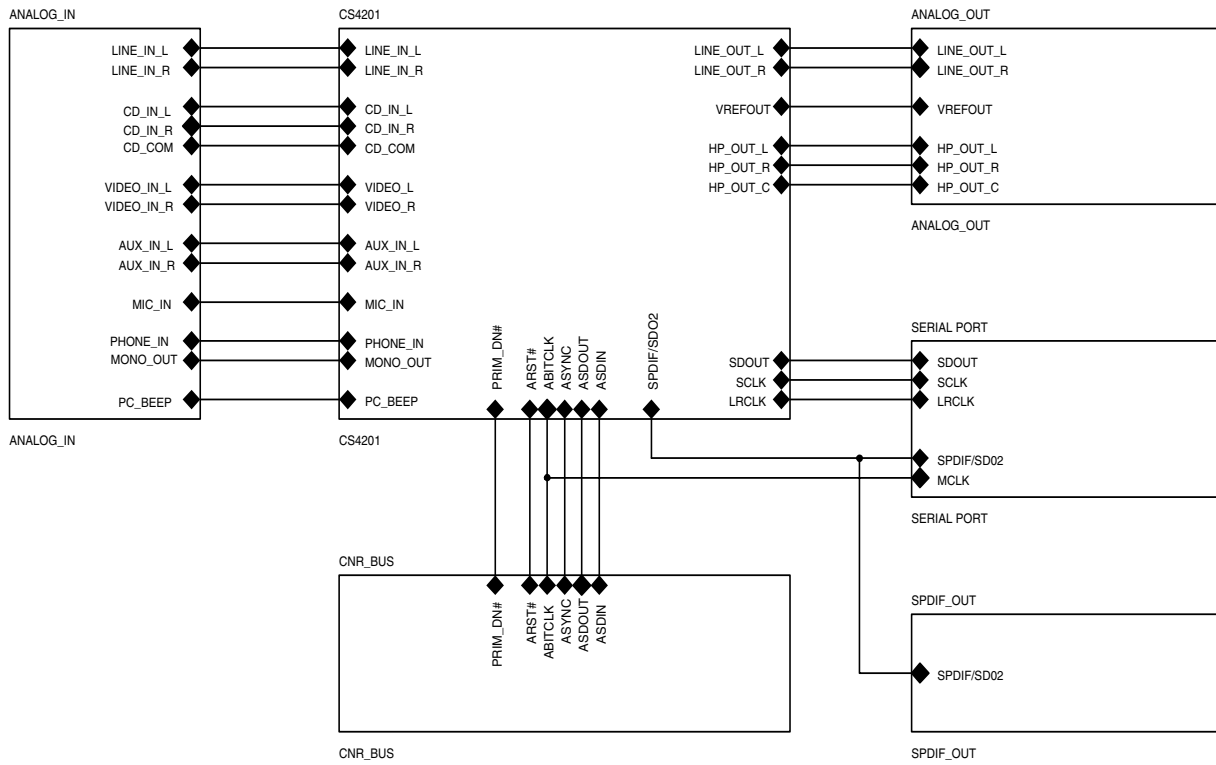

Figure 1. Block Diagram

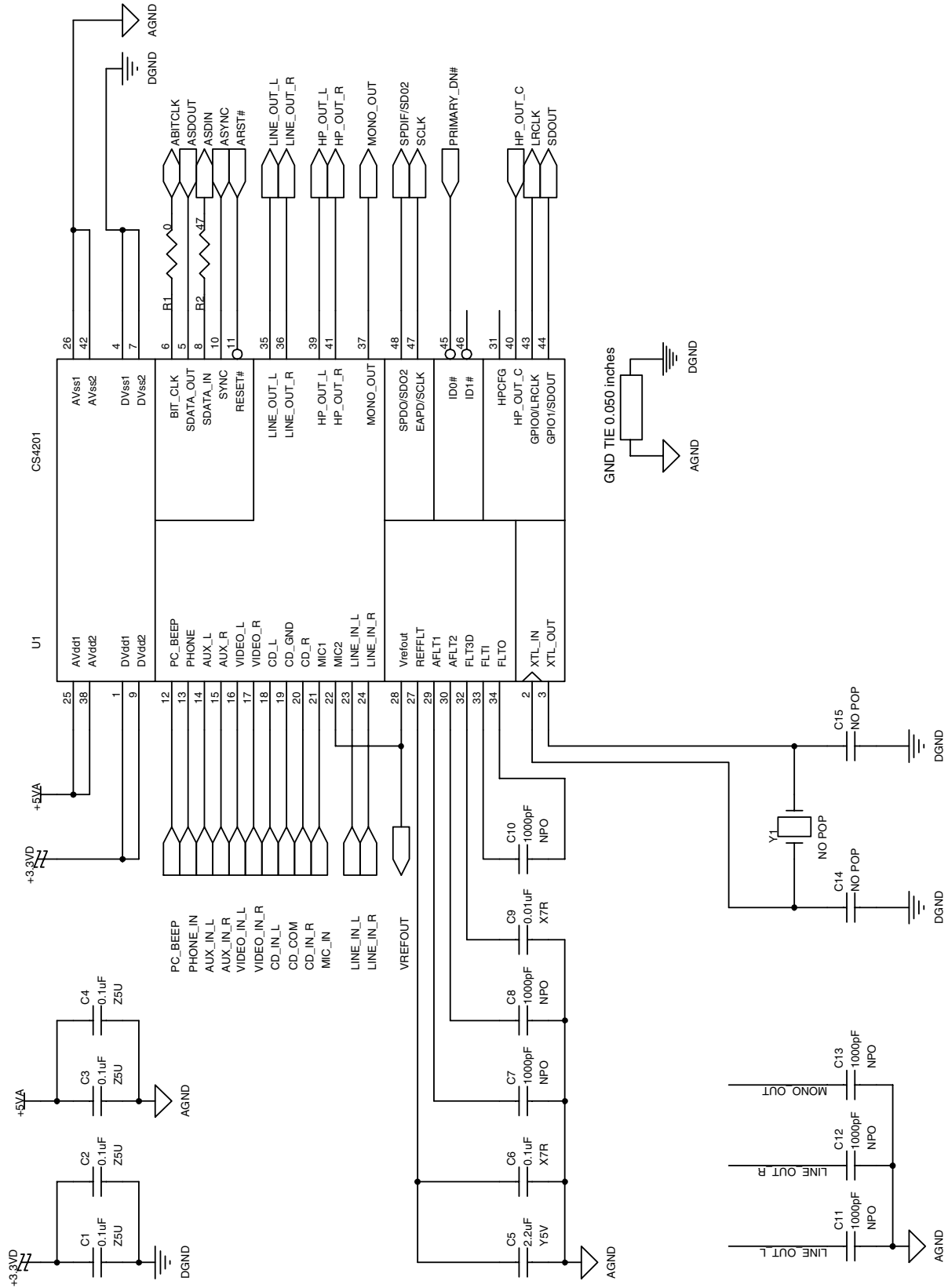

Figure 2. CS4201 Audio Codec

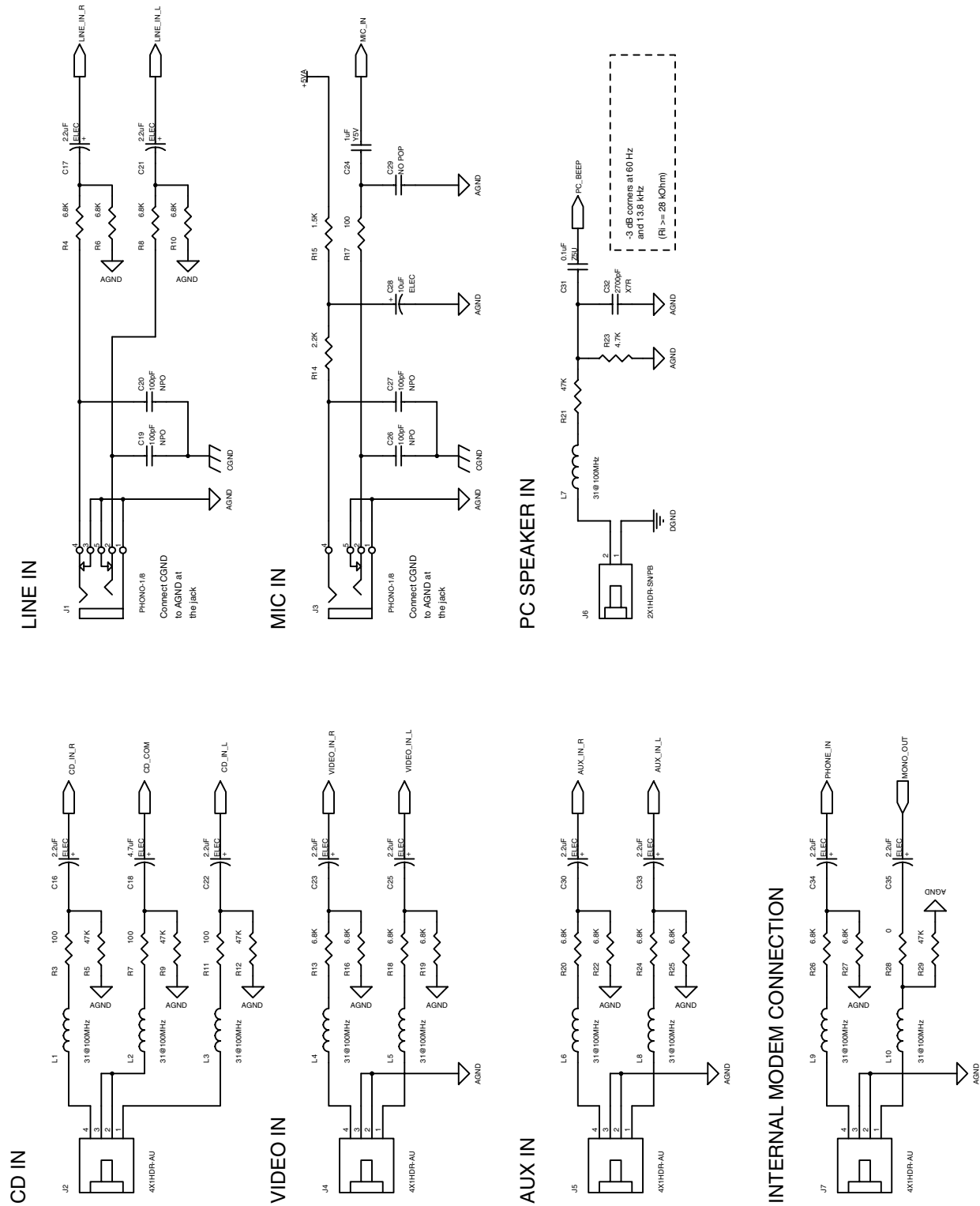

Figure 3. Analog Inputs

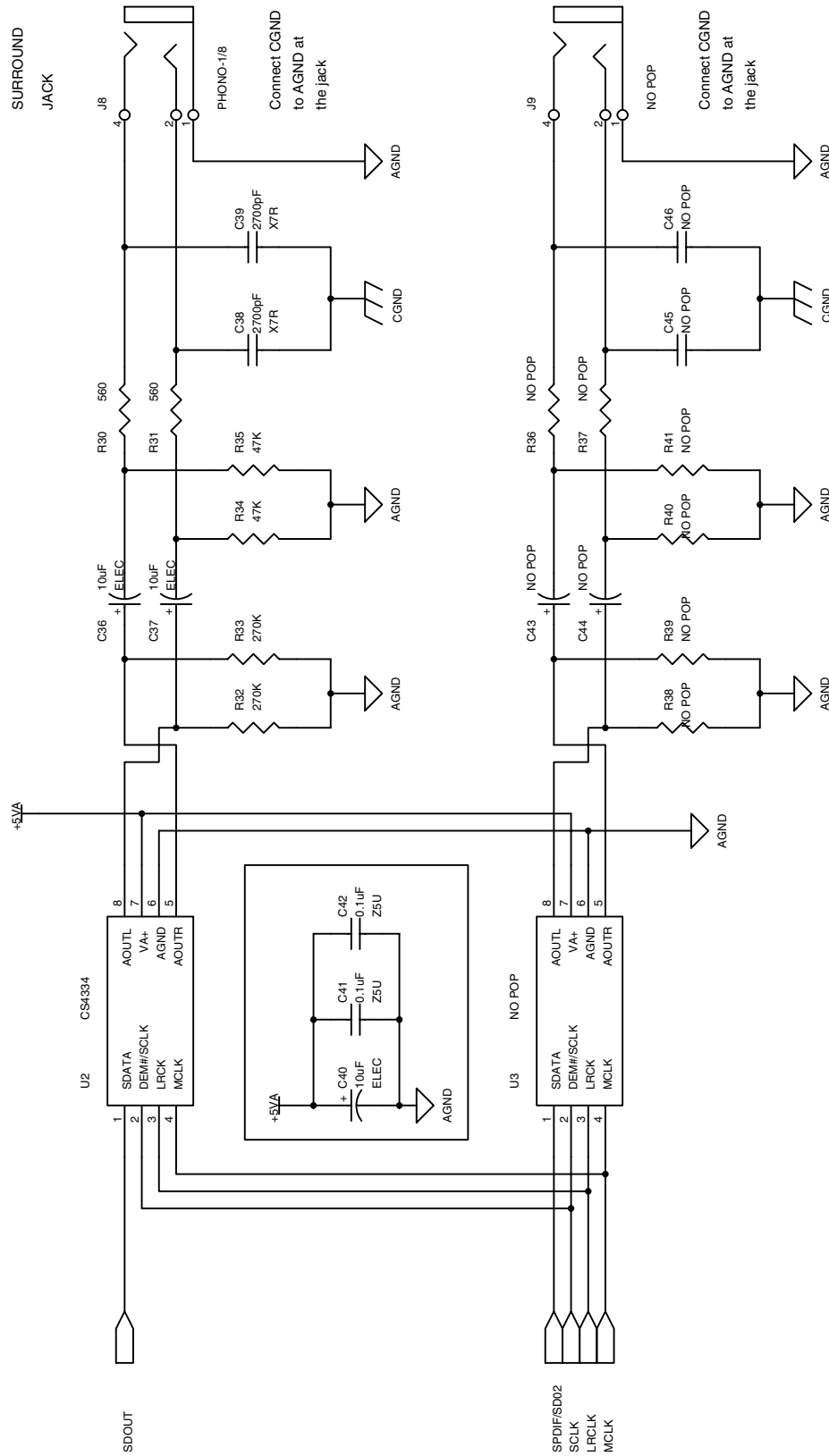

Figure 4. Rear Channel Outputs

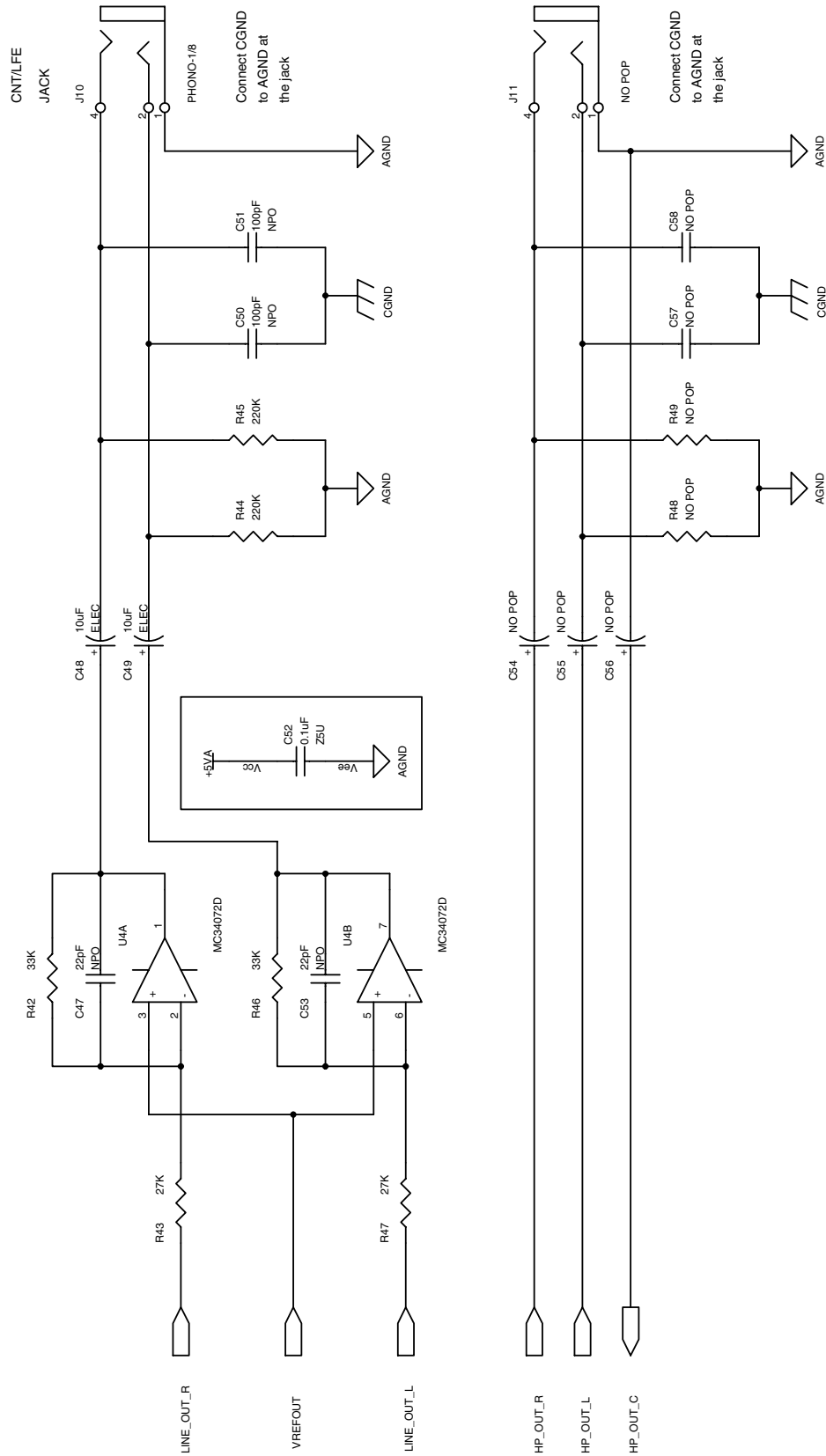

Figure 5. Center Channel and Sub-Woofers Outputs

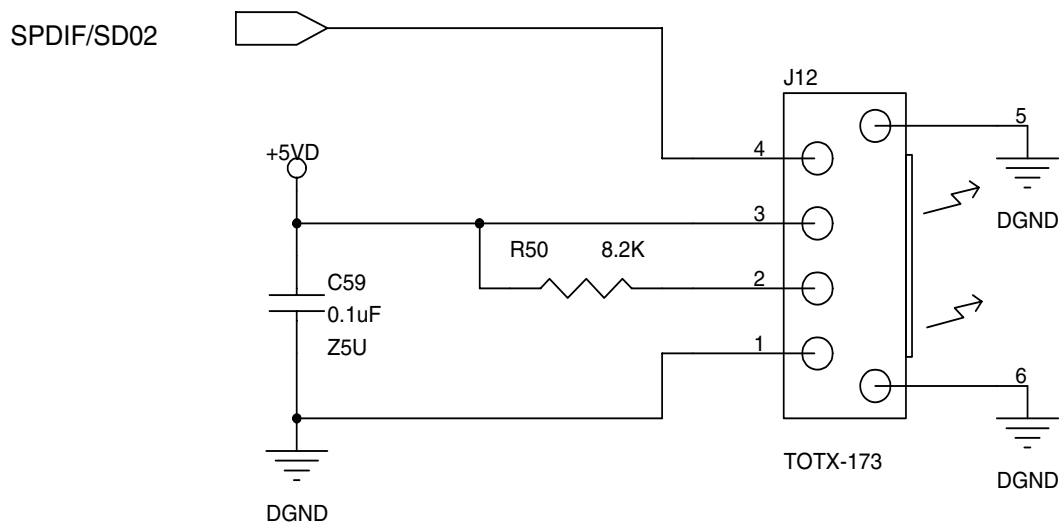

Figure 6. S/PDIF Optical Output

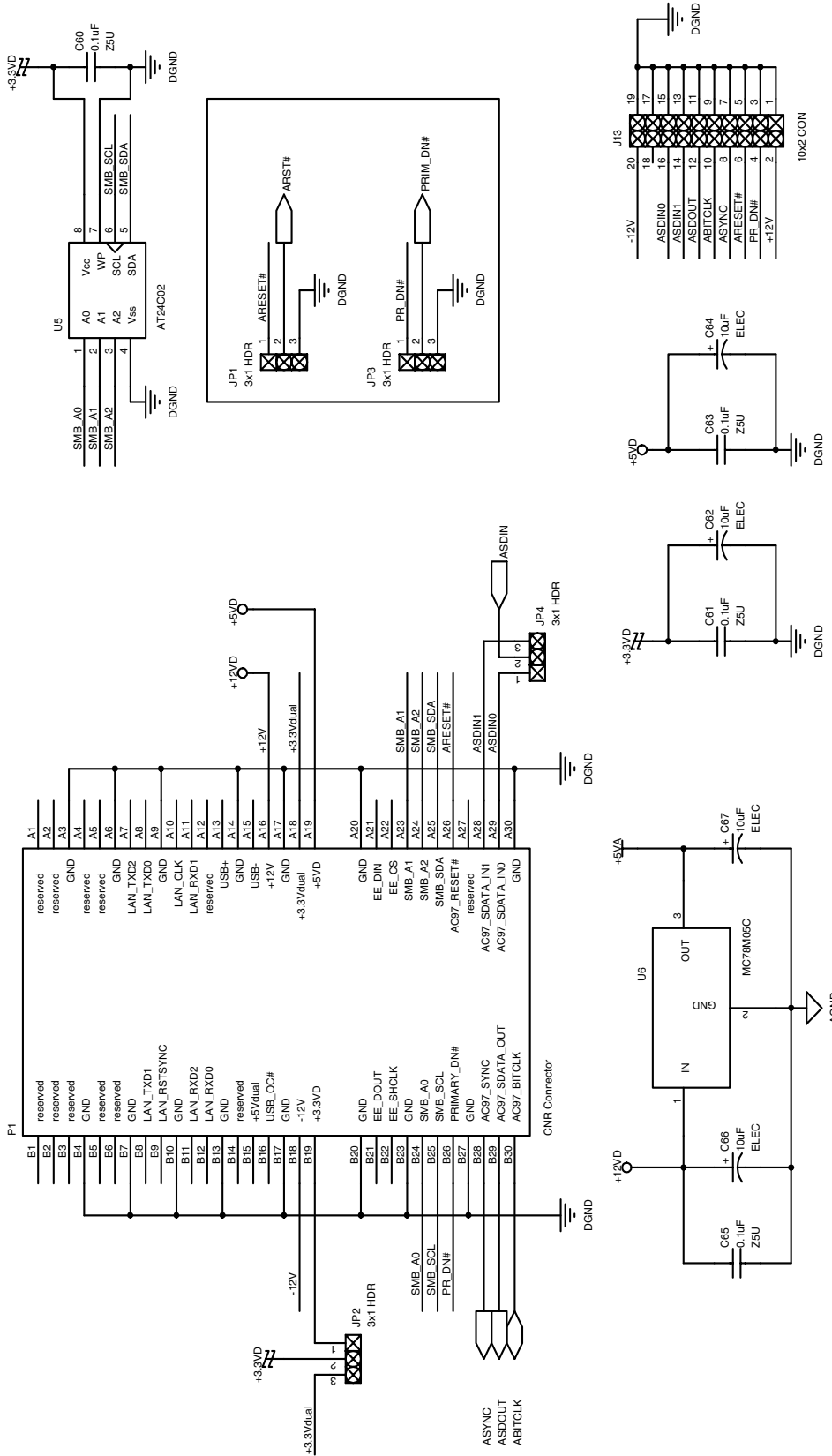

Figure 7. CNR Connector

Secondary card jumper connections:

- JP1 (2&3)
- JP2 (1&2)
- JP3 (2&3)
- JP4 (2&3)

Connect AGND to DGND with a 50 mil trace near the regulator.
 Connect CGND to DGND with a 50 mil trace near the regulator edge of the board.

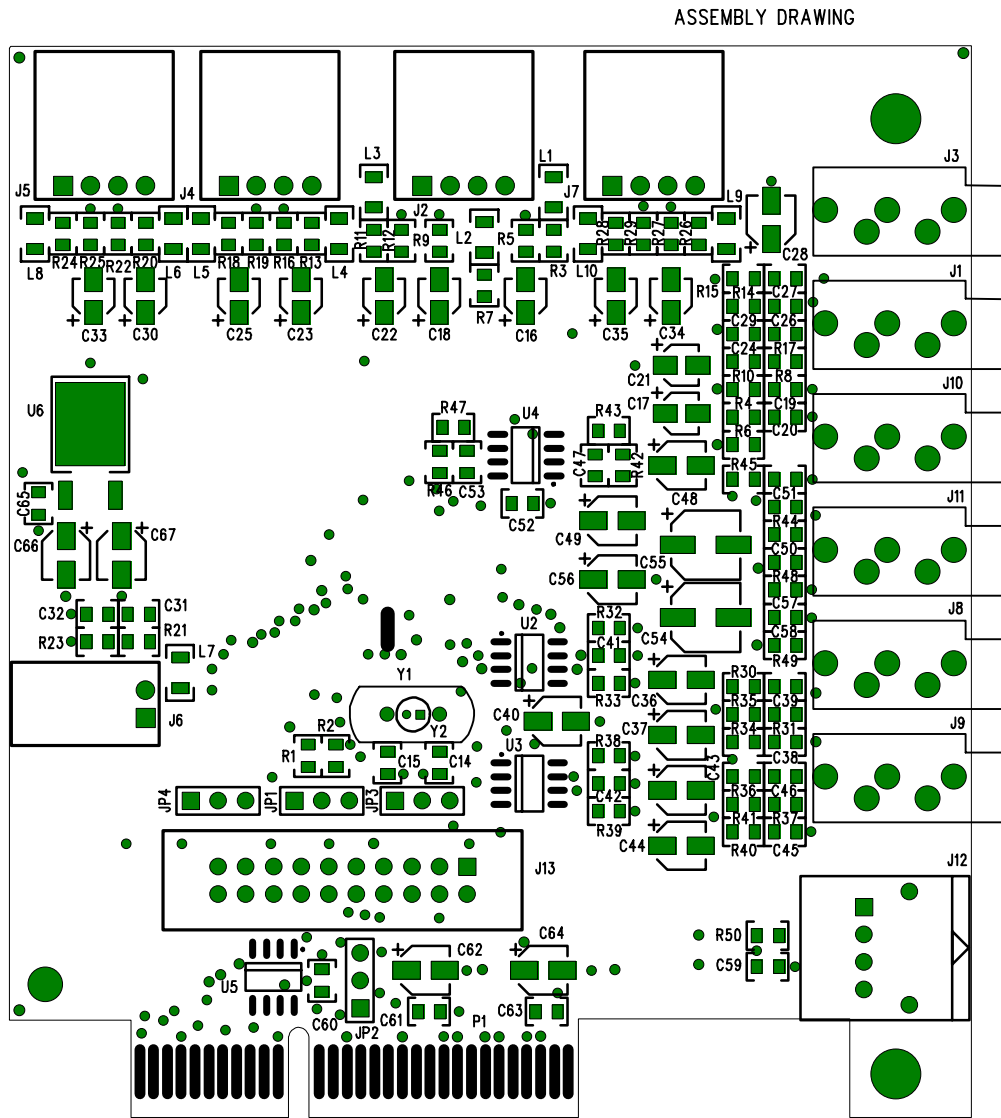

Figure 8. PCB Layout: Top Assembly Drawing

TOP LAYER-1

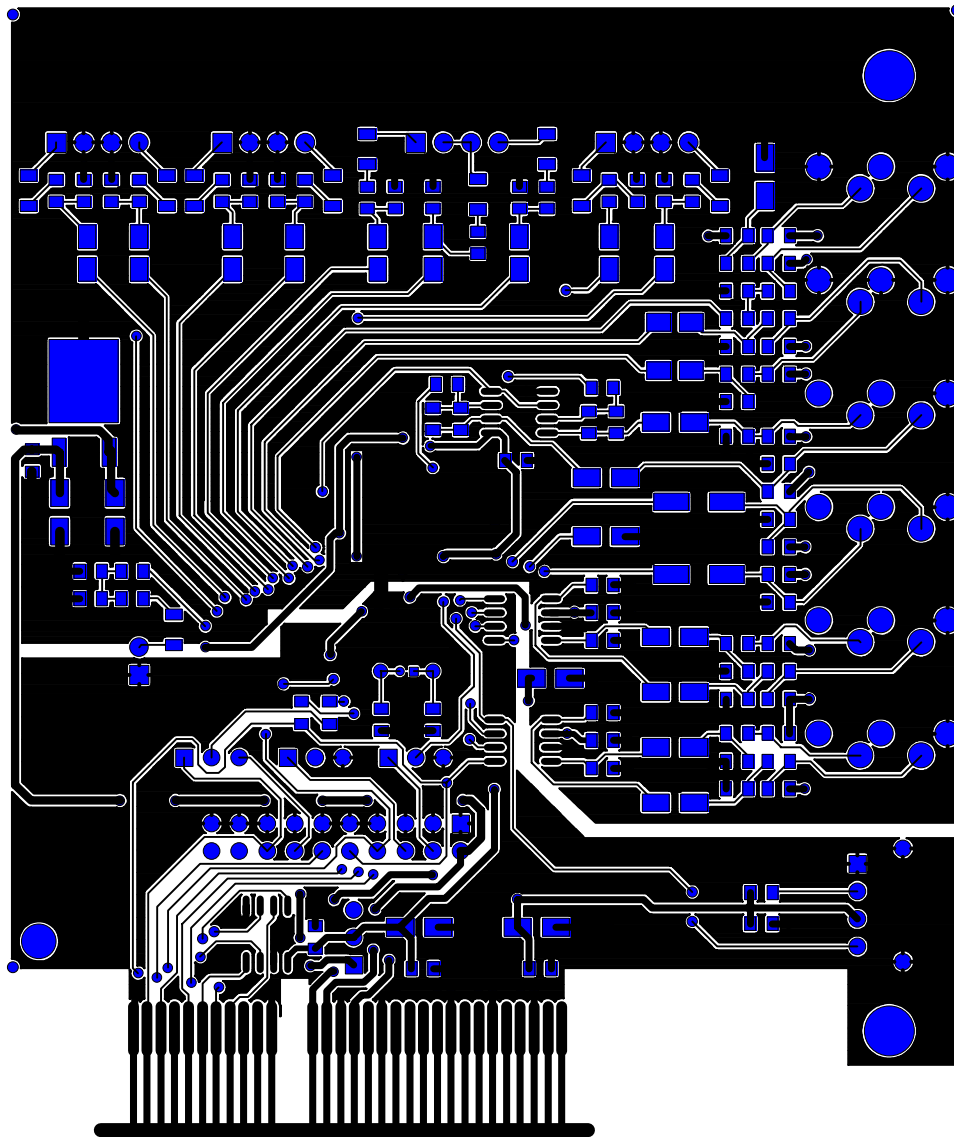

Figure 9. PCB Layout: Top Layer

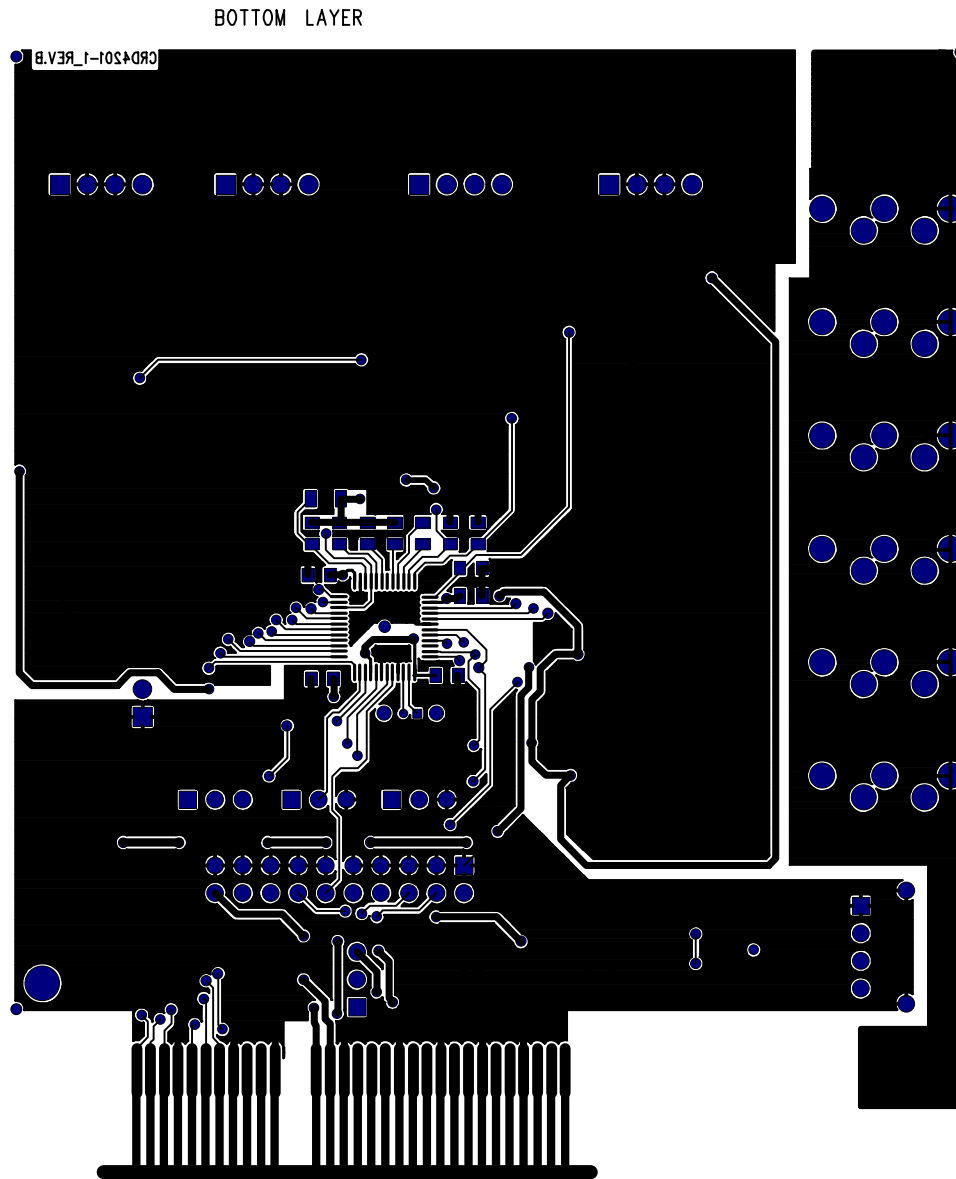

Figure 10. PCB Layout: Bottom Layer

ASSEMBLY DRAWING BOTTOM

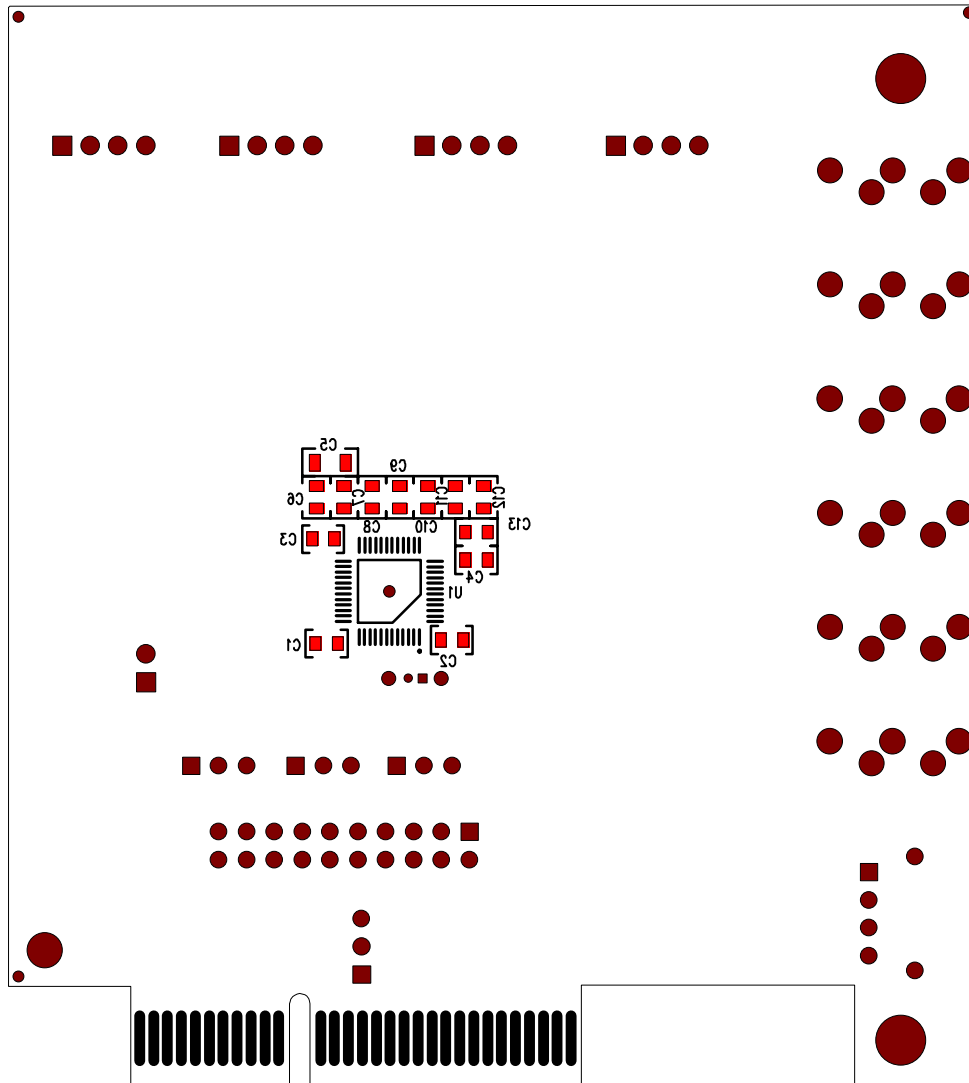

Figure 11. PCB Layout: Bottom Assembly

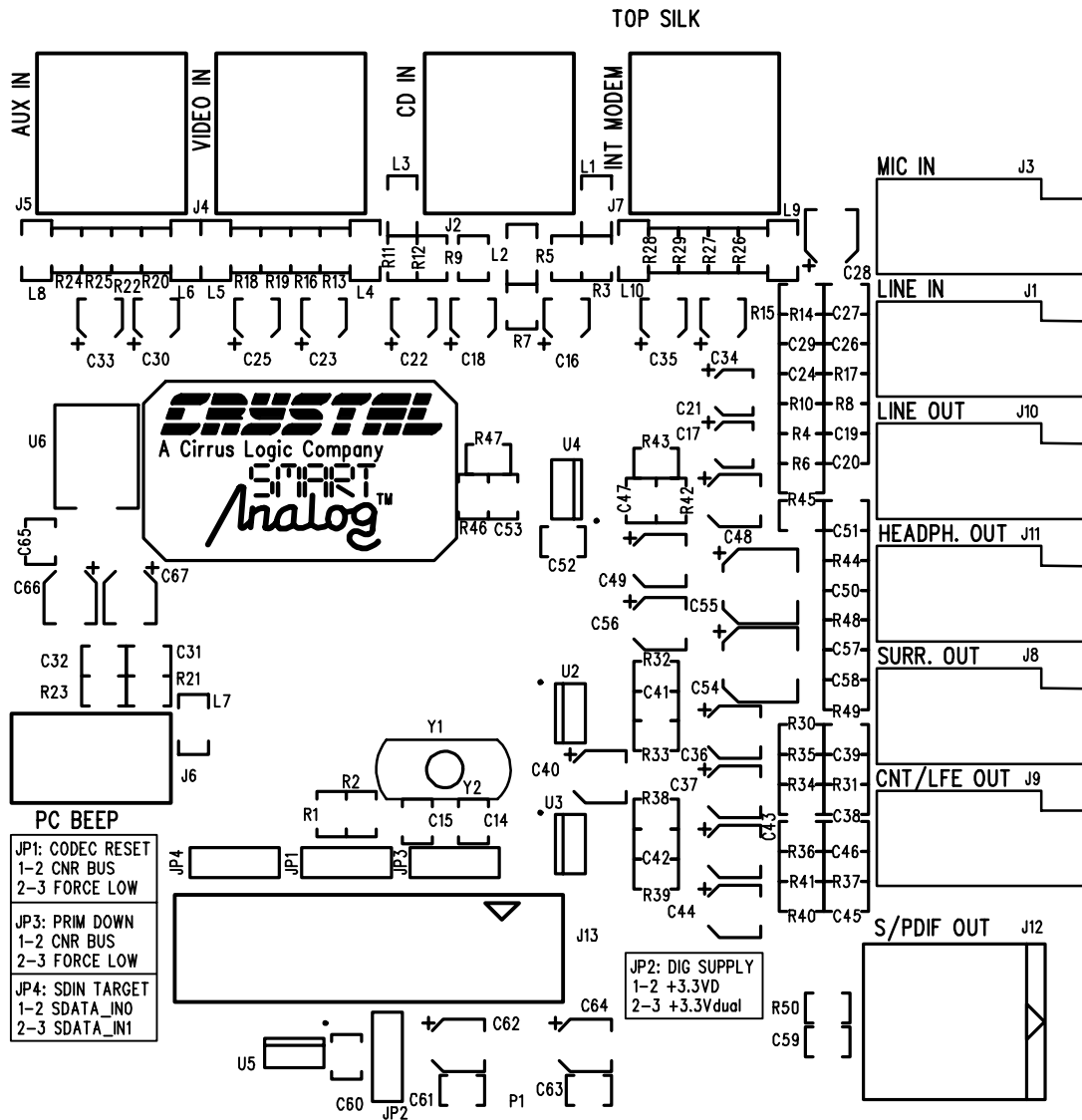

Figure 12. PCB Layout: Top Silkscreen

5. BILL OF MATERIALS

Item	Quantity	Reference	Manufacturer	Part Number	Description
1	13	C1,C2,C3,C4,C31,C41,C42, C52,C59,C60,C61,C63,C65	KEMET	C0805C104M5UAC	CAP, 0805, Z5U, .1uF, 20%, 50V
2	1	C5	KEMET	C1206C225M8VAC	CAP, 1206, Y5V, 2.2uF, 20%, 10V
3	1	C6	KEMET	C0805C104K5RAC	CAP, 0805, X7R, .1uF, 10%, 50V
4	6	C7,C8,C10,C11,C12,C13	KEMET	C0805C102K5GAC	CAP, 0805, C0G, 1000pF, 10%, 50V
5	1	C9	KEMET	C0805C103K5RAC	CAP, 0805, X7R, .01uF, 10%, 50V
6	7	C14,C15,C29,C45,C46,C57 C58	NO POP	NO POP	NO POP
7	10	C16,C17,C21,C22,C23,C25 C30,C33,C34,C35	PANASONIC	ECE-V1VS2R2SR	CAP, SMT A, ELEC, 2.2uF, 20%, 35V
8	1	C18	PANASONIC	ECE-V1ES4R7SR	CAP, SMT A, ELEC, 4.7uF, 20%, 25V
9	4	C19,C20,C26,C27	KEMET	C0805C101J5GAC	CAP, 0805, C0G, 100pF, 5%, 50V
10	1	C24	KEMET	C0805C105M8VAC	CAP, 0805, Y5V, 1uF, 20%, 10V
11	10	C28,C36,C37,C40,C48,C49 C62,C64,C66,C67	PANASONIC	ECE-V1CA100R	CAP, SMT B, ELEC, 10uF, 20%, 16V
12	3	C32,C38,C39	KEMET	C0805C272K5RAC	CAP, 0805, X7R, 2700pF, 10%, 50V
13	3	C43,C44,C56	NO POP	NO POP	NO POP
14	2	C53,C47	KEMET	C0805C220K5GAC	CAP, 0805, C0G, 22pF, 10%, 50V
15	2	C50,C51	KEMET	C0805C101J5GAC	CAP, 0805, C0G, 100pF, 5%, 50V
16	2	C54,C55	NO POP	NO POP	NO POP
17	4	JP1,JP2,JP3,JP4	SAMTEC	TSW-103-07-T-S	HDR, 3x1, 0.025" PIN, 0.1" CTR
18	1	J1	LZR ELECTRONICS	SJ372	CONN, 1/8" DOUBLE SW. STEREO PHONE JACK
19	4	J2,J4,J5,J7	MOLEX	70553-0003	HDR, 4X1, 0.025" PIN, 0.1" CTR, 15u" AU
20	1	J3	LZR ELECTRONICS	SJ374	CONN, 1/8" SINGLE SW. STEREO PHONE JACK

21	1	J6	MOLEX	70553-0036	HDR, 2X1, 0.025" PIN, 0.1" CTR, 150u" SN/PB
22	2	J8,J10	LZR ELECTRONICS	SJ373	CONN, 1/8" NON-SW. STEREO PHONE JACK
23	2	J9,J11	NO POP	NO POP	NO POP
24	1	J12	TOSHIBA	TOTX173	CONN, OPTICAL TOSLINK TRANSMITTER
25	1	J13	AMP	103309-5	CONN, 10x2 RIBBON, MALE, STRAIGHT, SHROUDED
26	10	L1,L2,L3,L4,L5,L6,L7,L8, L9,L10	TDK	HF50ACB321611-T	IND, FBEAD, 1206, 31@100MHz, 25%
27	1	P1	NONE	NONE	CNR BUS CONNECTOR
28	2	R1,R28	PHILIPS	9C08052A0R00J	RES, SO, 0805, 0, 5%, 1/10W, METAL FILM
29	1	R2	PHILIPS	9C08052A47R0J	RES, SO, 0805, 47, 5%, 1/10W, METAL FILM
30	4	R3,R7,R11,R17	PHILIPS	9C08052A1000J	RES, SO, 0805, 100, 5%, 1/10W, METAL FILM
31	14	R4,R6,R8,R10,R13,R16,R18, R19,R20,R22,R24,R25,R26	PHILIPS	9C08052A6801F	RES, SO, 0805, 6.8K, 1%, 1/10W, METAL FILM
32	7	R5,R9,R12,R21,R29,R34, R35	PHILIPS	9C08052A4702J	RES, SO, 0805, 47K, 5%, 1/10W, METAL FILM
33	1	R14	PHILIPS	9C08052A2201J	RES, SO, 0805, 2.2K, 5%, 1/10W, METAL FILM
34	1	R15	PHILIPS	9C08052A1501J	RES, SO, 0805, 1.5K, 5%, 1/10W, METAL FILM
35	1	R23	PHILIPS	9C08052A4701J	RES, SO, 0805, 4.7K, 5%, 1/10W, METAL FILM
36	2	R30,R31	PHILIPS	9C08052A5600J	RES, SO, 0805, 560, 5%, 1/10W, METAL FILM
37	2	R33,R32	PHILIPS	9C08052A2703J	RES, SO, 0805, 270K, 5%, 1/10W, METAL FILM
38	8	R36,R37,R38,R39,R40,R41 R48,R49	NO POP	NO POP	NO POP
39	2	R42,R46	PHILIPS	9C08052A3302F	RES, SO, 0805, 33K, 1%, 1/10W, METAL FILM
40	2	R43,R47	PHILIPS	9C08052A2702F	RES, SO, 0805, 27K, 1%, 1/10W, METAL FILM

41	2	R45,R44	PHILIPS	9C08052A2203J	RES, SO, 0805, 220K, 5%, 1/10W, METAL FILM
42	1	R50	PHILIPS	9C08052A8201J	RES, SO, 0805, 8.2K, 5%, 1/10W, METAL FILM
43	1	U1	CIRRUS LOGIC	CS4201-JQ	IC, TQFP, AC '97 2.1 SERIAL CODEC W/ HP AMP + SRC
44	1	U2	CIRRUS LOGIC	CS4334-KS	IC, SO, SOIC8, ADC, STEREO
45	1	U3	NO POP	NO POP	NO POP
46	1	U4	MOTOROLA	MC34072D	IC, SO, SOIC8, 34072, SINGLE SUPPLY DUAL OP AMP
47	1	U5	ATMEL	AT24C02N-10SC-2.7	IC, SO, SOIC8, SERIAL EEPROM, 256 x 8, 2.7V
48	1	U6	MOTOROLA	MC78M05CDD	IC, SO, +5V REGULATOR, DPAK, 4%, 500mA
49	1	Y1	NO POP	NO POP	NO POP

SMART
Analog™