

CrystalClear™ AC '97 Six Channel CNR Audio Reference Design

Features

- Six Channel Analog Audio Output
- Built-in Headphone Amplifier
- CS4201 audio codec and CS4334 DACs
- 20-bit D to A conversion (DAC)
- 18-bit A to D conversion (ADC)
- S/PDIF (IEC-958) optical digital output
- Complete suite of Analog I/O connections:
 - Line, Mic, CD, Video and Aux Inputs
 - Line Front, and Line Rear Outputs
- Joystick/MIDI Interface
- 2-layer low cost PC board
- Meets Intel® AC '97 version 2.1 specification
- Exceeds Microsoft's® PC 99 audio performance requirements.

Description

The CRD4201-1 CNR reference design features six channel analog audio outputs and a optical S/PDIF digital output. This board uses the CS4201 audio codec which has several advanced features such as a built-in headphone amplifier, up to 30 dB of microphone boost, and serial digital audio outputs.

The CRD4201-1 reference design is available by ordering the *CMK4201-1* manufacturing kit. This kit includes a full set of schematic design files (OrCAD® 7.2 format), PCB job files (PADS® ASCII), PCB artwork files, and bill of materials. This reference design offers significant cost savings over competing solutions and can be easily modified to meet your specific design goals.

ORDERING INFO

CMK4201-1 (Manufacturing Kit)

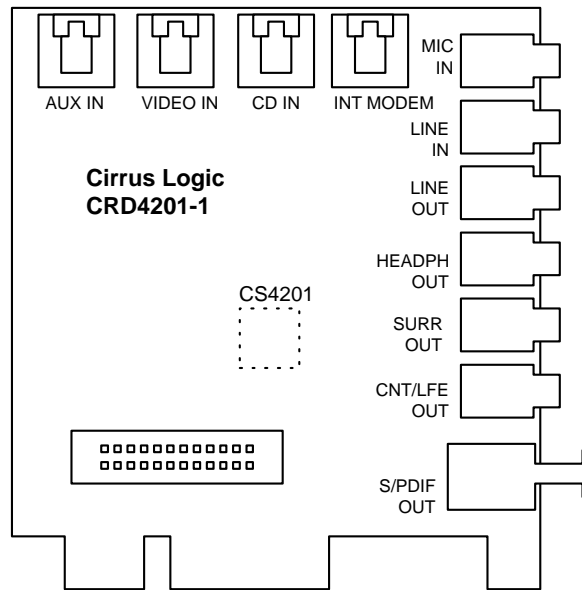

Preliminary Product Information

This document contains information for a new product. Cirrus Logic reserves the right to modify this product without notice.

TABLE OF CONTENTS

1. GENERAL INFORMATION	3
2. SCHEMATIC DESCRIPTION	3
2.1 CS4201 Audio Codec	3
2.2 Analog Inputs	3
2.3 Rear Channel and Surround Outputs	4
2.4 Front Channel and Headphone Outputs	4
2.5 S/PDIF Optical Output	4
2.6 CNR Connector and EEPROM	4
2.7 Component Selection	4
2.8 EMI Components	5
3. GROUNDING AND LAYOUT	5
3.1 Partitioned Voltage and Ground Planes	5
3.2 CS4201 Layout Notes	5
4. REFERENCES	6
4.1 ADDENDUM	6
5. BILL OF MATERIALS	19

LIST OF FIGURES

Figure 1. Block Diagram	7
Figure 2. CS4201 Audio Codec	8
Figure 3. Analog Inputs	9
Figure 4. Rear Channel and Surround Outputs	10
Figure 5. Front Channel and Headphone Outputs	11
Figure 6. S/PDIF Optical Output	12
Figure 7. CNR Connector	13
Figure 8. PCB Layout: Top Assembly Drawing	14
Figure 9. PCB Layout: Top Layer	15
Figure 10. PCB Layout: Bottom Layer	16
Figure 11. PCB Layout: Bottom Assembly	17
Figure 12. PCB Layout: Top Silkscreen	18

Contacting Cirrus Logic Support

For a complete listing of Direct Sales, Distributor, and Sales Representative contacts, visit the Cirrus Logic web site at:

<http://www.cirrus.com/corporate/contacts/>

Microsoft , Windows 95, Windows 98 and Windows Millennium and WHQL is registered trademark of Microsoft.

CrystalClear is a trademark of Cirrus Logic, Inc.

Intel is a registered trademark of Intel Corporation.

OrCAD is a registered trademark of OrCAD, Inc.

PADS is a registered trademark of, PADS Software, Inc.

Preliminary product information describes products which are in production, but for which full characterization data is not yet available. Advance product information describes products which are in development and subject to development changes. Cirrus Logic, Inc. has made best efforts to ensure that the information contained in this document is accurate and reliable. However, the information is subject to change without notice and is provided "AS IS" without warranty of any kind (express or implied). No responsibility is assumed by Cirrus Logic, Inc. for the use of this information, nor for infringements of patents or other rights of third parties. This document is the property of Cirrus Logic, Inc. and implies no license under patents, copyrights, trademarks, or trade secrets. No part of this publication may be copied, reproduced, stored in a retrieval system, or transmitted, in any form or by any means (electronic, mechanical, photographic, or otherwise) without the prior written consent of Cirrus Logic, Inc. Items from any Cirrus Logic website or disk may be printed for use by the user. However, no part of the printout or electronic files may be copied, reproduced, stored in a retrieval system, or transmitted, in any form or by any means (electronic, mechanical, photographic, or otherwise) without the prior written consent of Cirrus Logic, Inc. Furthermore, no part of this publication may be used as a basis for manufacture or sale of any items without the prior written consent of Cirrus Logic, Inc. The names of products of Cirrus Logic, Inc. or other vendors and suppliers appearing in this document may be trademarks or service marks of their respective owners which may be registered in some jurisdictions. A list of Cirrus Logic, Inc. trademarks and service marks can be found at <http://www.cirrus.com>.

1. GENERAL INFORMATION

The CRD4201-1 reference design is a CNR card that features six channel CD quality analog audio outputs. The card includes a CS4201 AC '97 audio codec and two CS4334 24-bit serial stereo DACs. This combination gives the CRD4201-1 a rich feature set and industry leading audio performance.

The CS4201 audio codec has a stereo 20-bit DAC, a stereo 18-bit ADC and a very flexible analog audio mixer. The serial data outputs are paired with two CS4334 DACs to provide four additional channels of analog audio. The CS4201 also features three stereo pairs of line level analog inputs, a microphone input, and a stereo pseudo-differential CD input. The input signals can be routed to the ADC for recording or mixed together for recording and direct playback. The CS4201 has internal registers that are used to control its various features such as volume levels, audio muting, and signal routing. The CS4201 maintains high audio quality and exceeds the Microsoft[®] PC-99 audio performance specification.

The CS4201 audio codec communicates to the audio controller across the CNR interface through the AC-Link. The AC-Link is a 5-wire serial digital interface that transfers digital audio between the two devices and also sends commands from the audio controller to the CS4201's registers. For more information on the AC-Link, see the Intel[®] AC'97 version 2.1 specification.

2. SCHEMATIC DESCRIPTION

The block diagram in Figure 1 illustrates the interconnections between the various schematic pages found at the end of this document. Sections 2.1 through 2.8 describe the circuitry contained in these schematics.

2.1 CS4201 Audio Codec

The CS4201 audio codec is shown in Figure 2. The input signals to the CS4201 originate from the analog inputs in Figure 3, and the analog outputs are

shown in Figure 5. AFLT1 and AFLT2 (pins 29, 30) require 1000 pF NPO/COG capacitors connected to analog ground. These capacitors provide a single pole lowpass filter at the inputs of the ADC. No other input filtering is required.

FLT3D, FLTI, and FLTO (pins 32, 33, 34) form the internal analog 3D enhancement filter. The FLT3D pin requires a 0.01 μ F capacitor to analog ground. The FLT0 and FLT1 pins require a NPO/COG 1000 pF series capacitor.

The AC-Link may require series termination resistors to prevent reflections. These are normally placed as close as possible to the transmitting end of a particular AC-Link signal. Both SDATA_IN (pin 8) and BIT_CLK (pin 6) are outputs of the CS4201 and each have a 47 Ω series termination resistor.

The CS4201 is powered by separate analog and digital power supplies, each with their own respective grounds. The AGND symbols refer to analog ground, and DGND symbols refer to digital ground. Each power pin needs separate decoupling capacitors. The CS4201 audio codec uses a 0.1 μ F ceramic capacitor for each of the 3.3 V digital and 5 V analog supply pins. These decoupling capacitors are placed as close as possible to their respective pins.

2.2 Analog Inputs

The LINE_IN, VIDEO, and AUX_IN stereo input jacks in Figure 3 are connected to a 6 dB voltage divider and AC coupled to the CS4201. The voltage divider allows input signal levels of up to 2 V_{rms}. The 2.2 μ F AC coupling capacitor values are used to minimize low frequency roll-off.

The microphone circuit is AC coupled and also provide bandpass filtering on the incoming microphone signal. This bandpass filter was designed for a 3 dB rolloff at 60 Hz and 15 kHz. The microphone circuit provides low voltage phantom power for electret microphones. Phantom power is de-

rived from the +5 V analog supply and provides a maximum of 4.2 V under no load and a minimum of 2.0 V under a 0.8 mA load. These parameters are required by PC-99.

The CS4201 features a pseudo-differential CD input that minimizes common mode noise and interference. Each CD signals acts as one side of the differential input and CD_COM acts as the other side. CD_COM is used as the common return path for both the left and right channels. For good common mode rejection performance, the voltage divider resistors for CD_COM are half the value of those for CD L and R inputs.

2.3 Rear Channel and Surround Outputs

The outputs in Figure 4 drive the rear speakers (surround), center speaker (CNT), and sub-woofer (LFE) in a six channel audio application. These four outputs are driven digitally from the CS4201 through two serial output ports and converted to analog audio through two high-performance CS4334 24-bit stereo DACs.

2.4 Front Channel and Headphone Outputs

Figure 5 details the Headphone Output and Line Output circuits. The Line Outputs are the main analog outputs in a two channel system or the Front Outputs in a six channel audio system.

The Line Outputs of the CS4201 (pins 35 and 36) are buffered by a Motorola MC34072 dual op-amp. The MC34072 is a high performance low noise op-amp well suited for audio applications. Line Out is designed to drive high impedance loads of 10 K Ω or higher.

The CS4201 has a built in headphone amplifier on pins 39 and 41. These outputs are capable of driving headphones with impedances as low as 32 Ω . The headphone outputs are AC coupled through 220 μ F capacitors. These large capacitor values create excellent low frequency response even under 32 Ω loads.

2.5 S/PDIF Optical Output

The S/PDIF (IEC-958) digital output shown in Figure 6, is compatible with digital outputs on consumer devices such as Mini Disk recorders and consumer stereo receivers. The S/PDIF output operates at a fixed sampling frequency of 48 KHz. It uses an industry standard TOSLINK digital optical transmitter, the Toshiba TOTX-173.

2.6 CNR Connector and EEPROM

The Communications and Network Riser interface (CNR) is shown in Figure 7. CNR is a motherboard interface that supports audio, modem and LAN subsystems. CNR applications are targeted at OEMs, system manufacturers, and system integrators who wish take advantage of physically separating their audio, modem or LAN circuitry from the PC motherboard. CNR accomplishes this with out the additional cost associated with the interface circuitry required for a PCI bus add-in card. Manufacturers of aftermarket add-in cards should still use the PCI bus. For that application, Cirrus Logic offers the CRD4630-10 six channel PCI add-in card reference design (order information: CMK4630-10).

The CRD4201-1 uses the AC-Link, SMBus and power. The SMBus is used to provide Plug-and-Play functionality for the CNR card. The SMBus signals are connected to a AT24C02 EEPROM. The EEPROM holds the Subsystem Vendor ID and Subsystem ID. It also contains other information for implementing a plug-and-play CNR card. For CNR design specifications, programming utilities, and information on programming the EEPROM see the Intel[®] Communication and Network Riser (CNR) homepage at <http://developer.intel.com/technology/cnr/>.

2.7 Component Selection

Great attention was given to the particular components used on the CRD4201-1 board with cost, performance, and package selection as the most

important factors. Listed are some of the guidelines used in the selection of components:

- No components smaller than 0805 SMT package.
- Only single package passive components. No resistor packs. This reduces the risk of crosstalk between analog audio signals.
- All components except connectors, jumpers and the 24.576 MHz crystal are in surface mount packages.
- Dual footprints are used for the 24.576 MHz crystal.

2.8 EMI Components

Optional capacitors and inductors are included to help the board meet EMI compliance tests, such as FCC Part 15. Choose these component values according to individual requirements.

3. GROUNDING AND LAYOUT

The component layout and signal routing of the CRD4201-1 provides a good model for laying out your own CNR add-in card.

3.1 Partitioned Voltage and Ground Planes

It is critical for good audio performance to separate digital and analog sections to prevent digital noise from effecting the performance of the analog circuits. The analog section of the CRD4201-1 is completely isolated from the digital section with a 100 mil partition. Partitioning is defined as the absence of copper on all signal layers. The analog and digital sections each have their own separate ground planes. All analog components, power traces, and signal traces are routed over the analog ground plane. Digital components, power traces and signal traces are not allowed to crossover into the analog section.

The CS4201 audio codec is placed at the transition point between the analog and digital ground planes. The pins are arranged on the CS4201 so that the analog and digital signals are separated from each other. *The analog and digital ground planes must be tied together for the CS4201 to maintain proper voltage references.* For best results, the two ground planes are tied together with a single 50 mil trace under the CS4201 near its digital ground pins.

Data converters are generally susceptible to noise on the crystal pins. In order reduce noise from coupling onto these pins, the area around the 24.576 MHz crystal and its signal traces is filled with copper on the top and bottom of the PCB and attached to digital ground.

A separate chassis ground provides a noise-free reference point for all of the EMI suppression components. The chassis ground plane is connected to the analog ground plane at the external jacks.

3.2 CS4201 Layout Notes

Refer to the *CS4201 Data Sheet* for analog and digital partitioning guidelines and bypass capacitors placement. Pay special attention to the bypass capacitors on REFFLT, AFLT1, AFLT2 and the power supply capacitors.

Schematic & Layout Review Service

Confirm Optimum
Schematic & Layout
Before Building Your Board.

For Our Free Review Service
Call Applications Engineering.



C a l l : (5 1 2) 4 4 5 - 7 2 2 2

4. REFERENCES

- 1) Intel[®], Audio Codec '97 Component Specification, Revision 2.1, May 22, 1998.
<http://developer.intel.com/>
- 2) Intel[®], CNR Specification 1.0
<http://developer.intel.com/technology/cnr/index.htm>
- 3) Cirrus Logic, CS4201 Audio Codec '97 Data Sheet
<http://www.cirrus.com/products>
- 4) Steve Harris, Clif Sanchez, Personal Computer Audio Quality Measurements, Ver 1.0
<http://www.cirrus.com/pubs/meas100.pdf>
- 5) Microsoft, PC Design Guidelines,
<http://www.microsoft.com/hwdev/desguid/>
- 6) M. Montrose. Printed Circuit Board Design Techniques for EMC Compliance, IEEE Press, New York: 1996.

4.1 ADDENDUM

- Schematic drawings
- Layout drawings
- Bill of materials

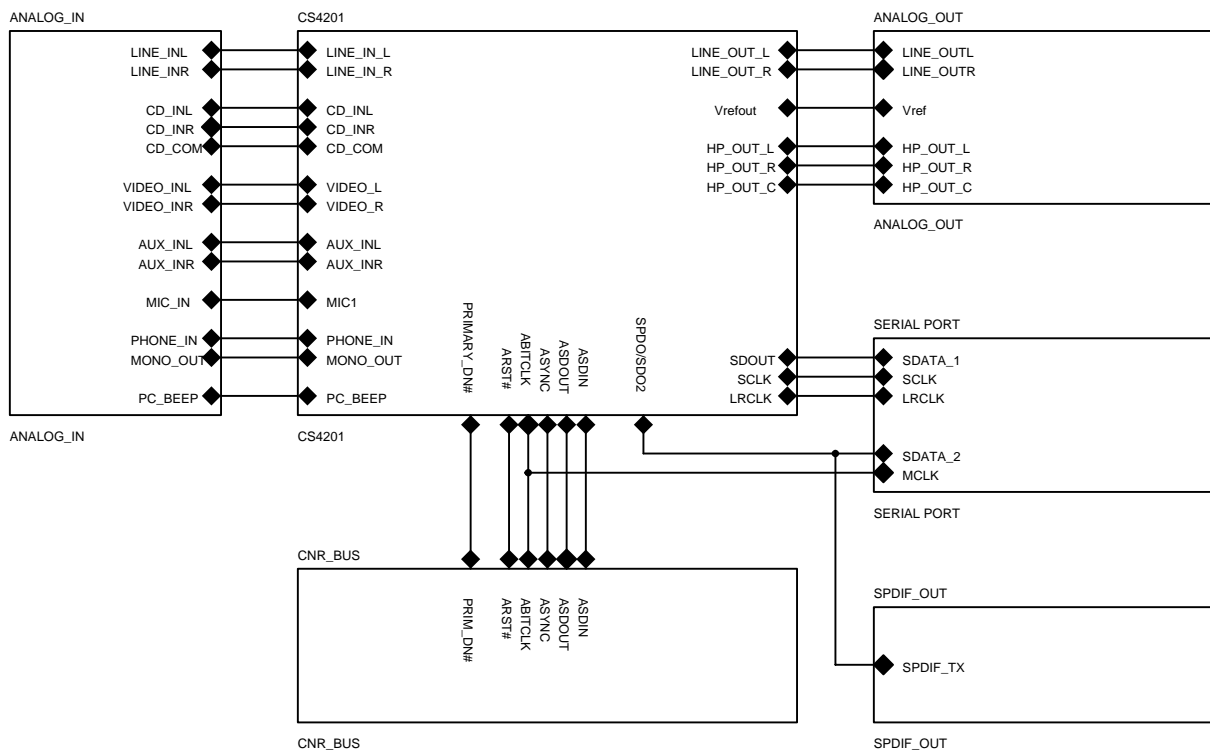

Figure 1. Block Diagram

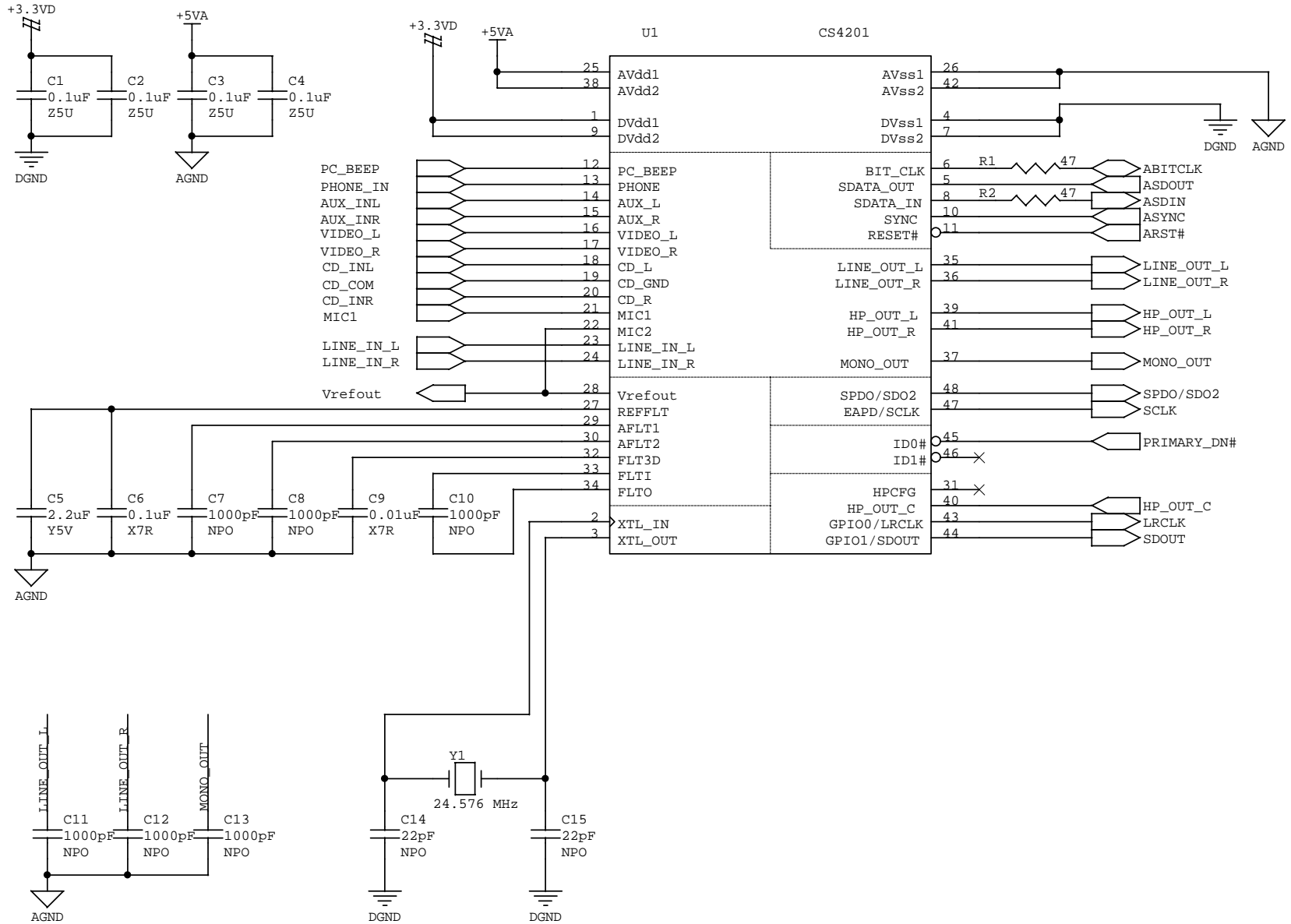
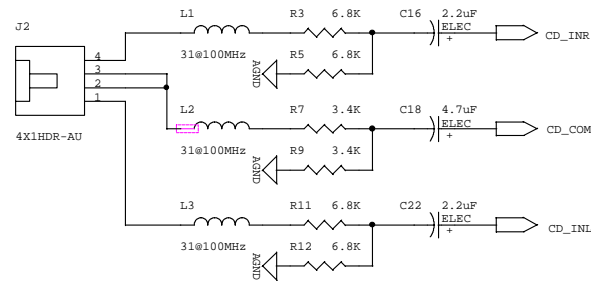

Figure 2. CS4201 Audio Codec



CD IN



VIDEO IN

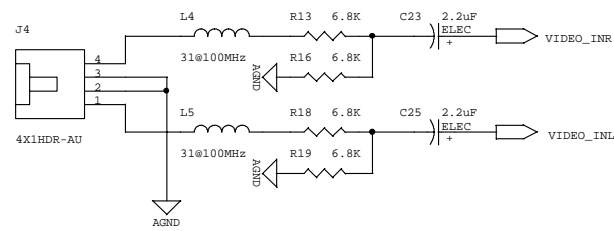

AUX IN

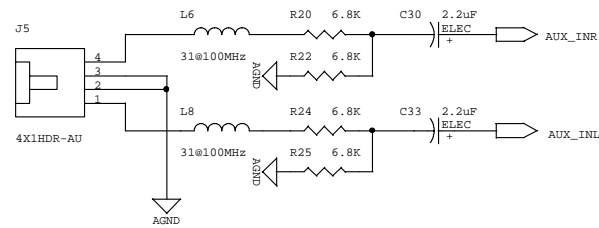

INTERNAL MODEM CONNECTION

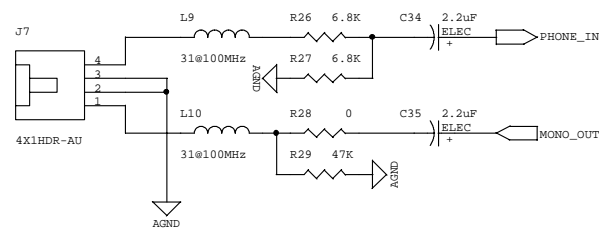

LINE IN

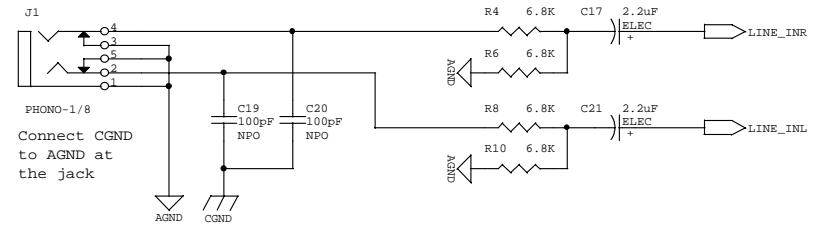

MIC IN

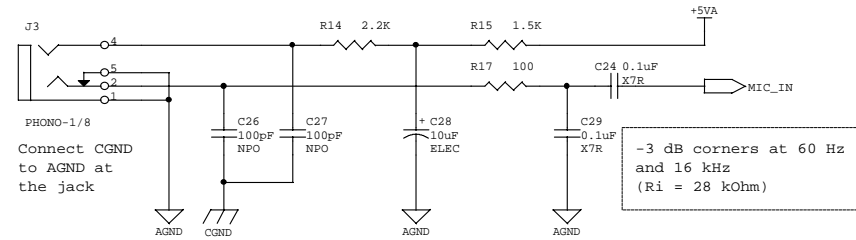

PC SPEAKER IN

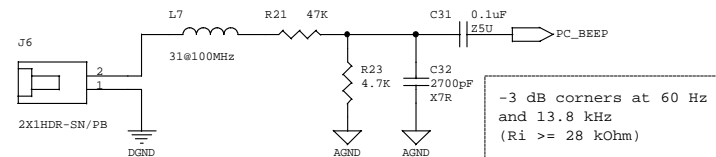

Figure 3. Analog Inputs

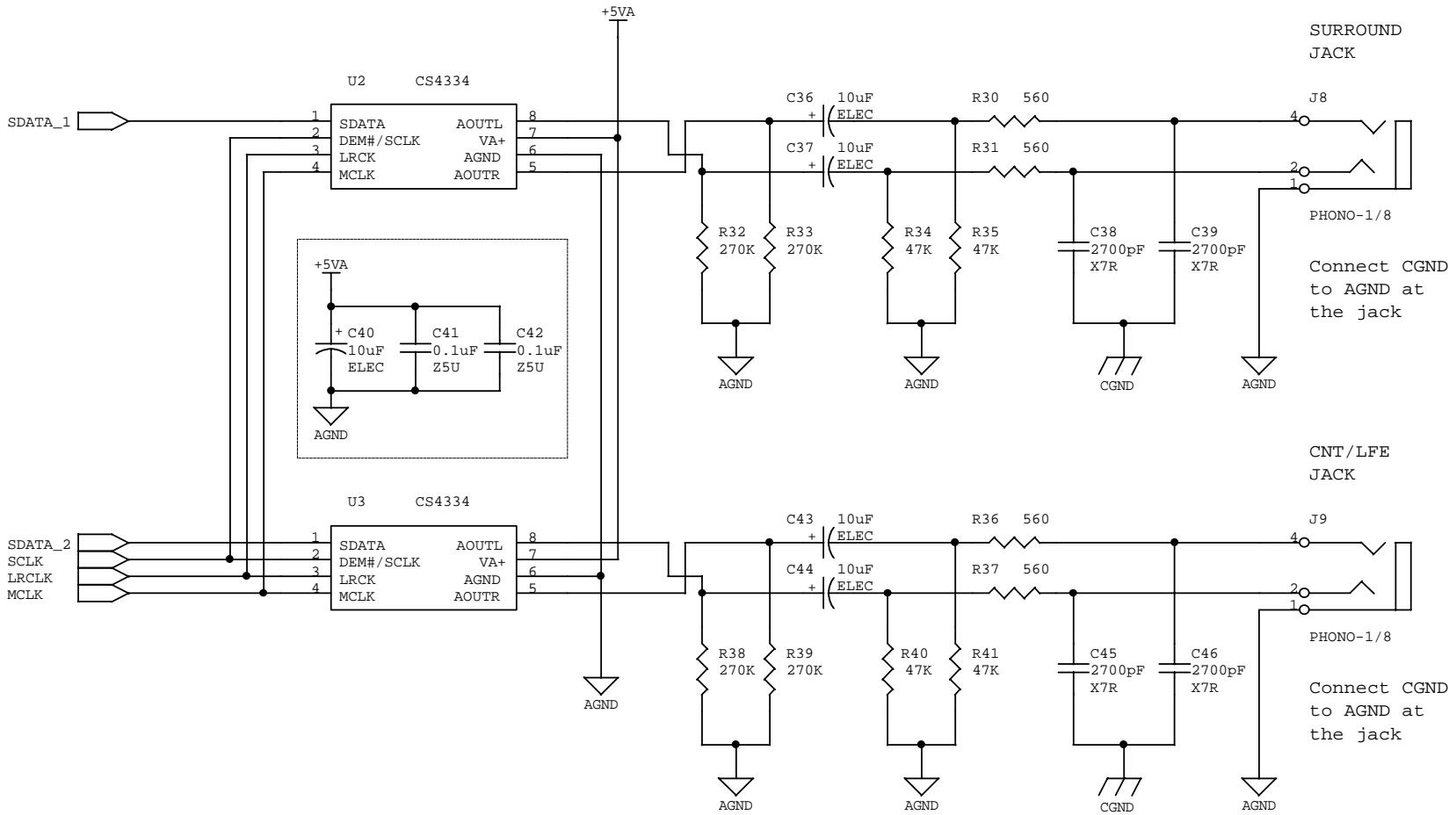

Figure 4. Rear Channel and Surround Outputs



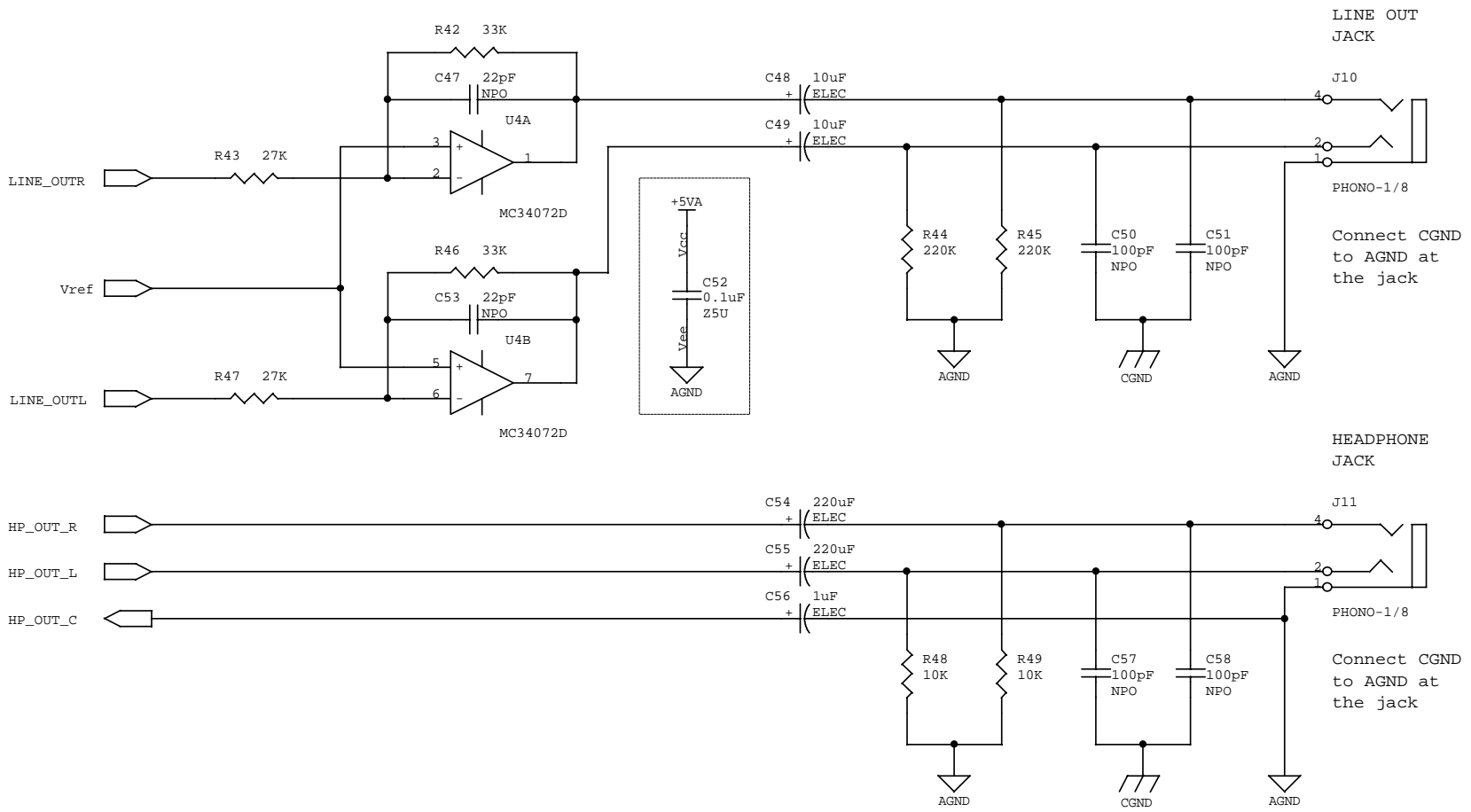

Figure 5. Front Channel and Headphone Outputs

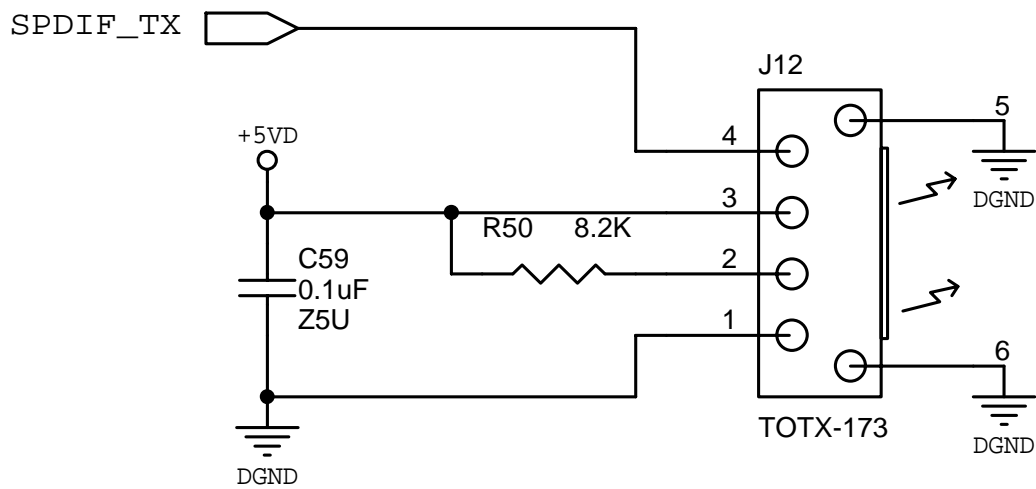
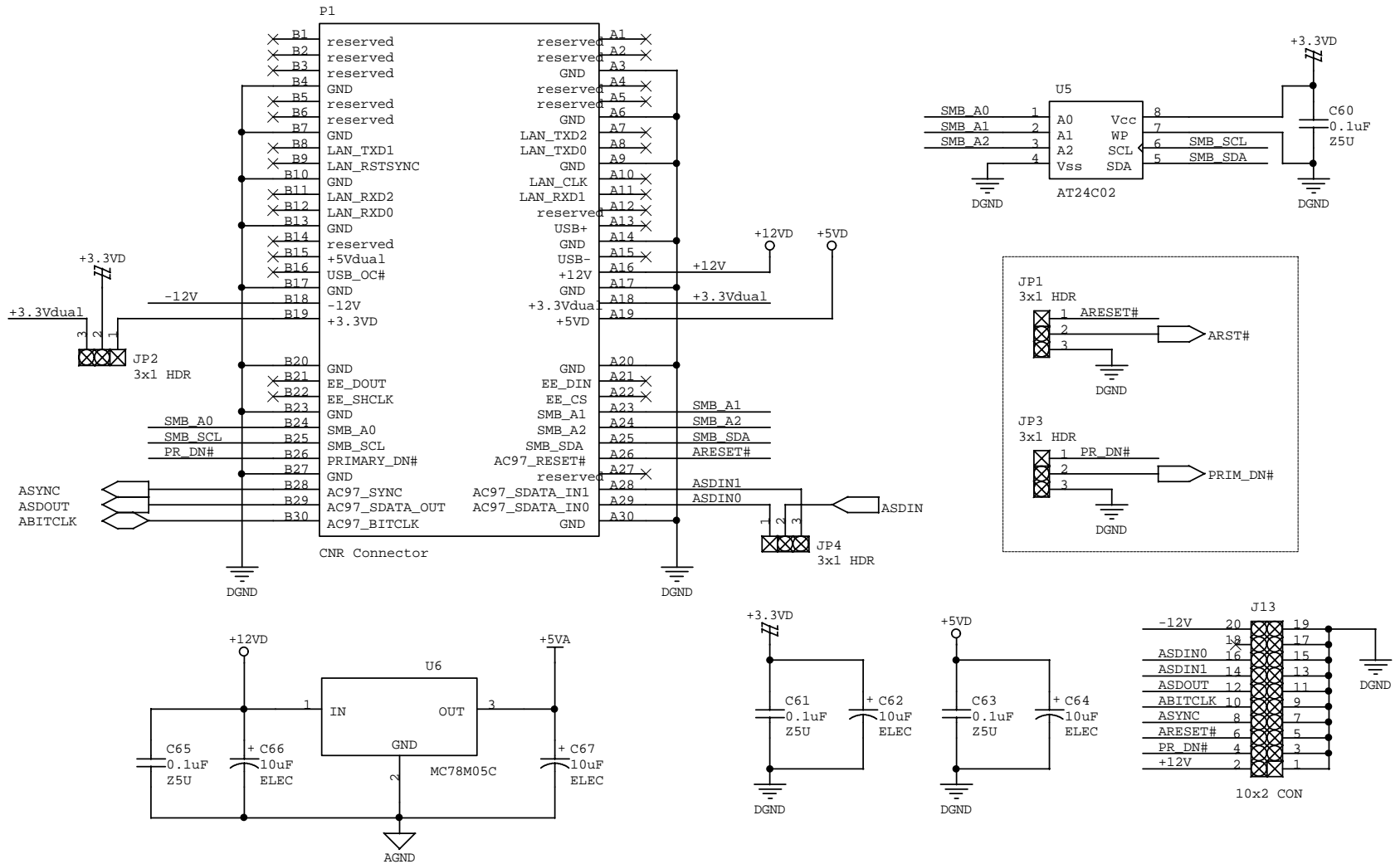

Figure 6. S/PDIF Optical Output



Connect AGND to DGND with a 50 mil trace near the regulator.
 Connect CGND to DGND with a 50 mil trace near the finger edge of the board.

Figure 7. CNR Connector



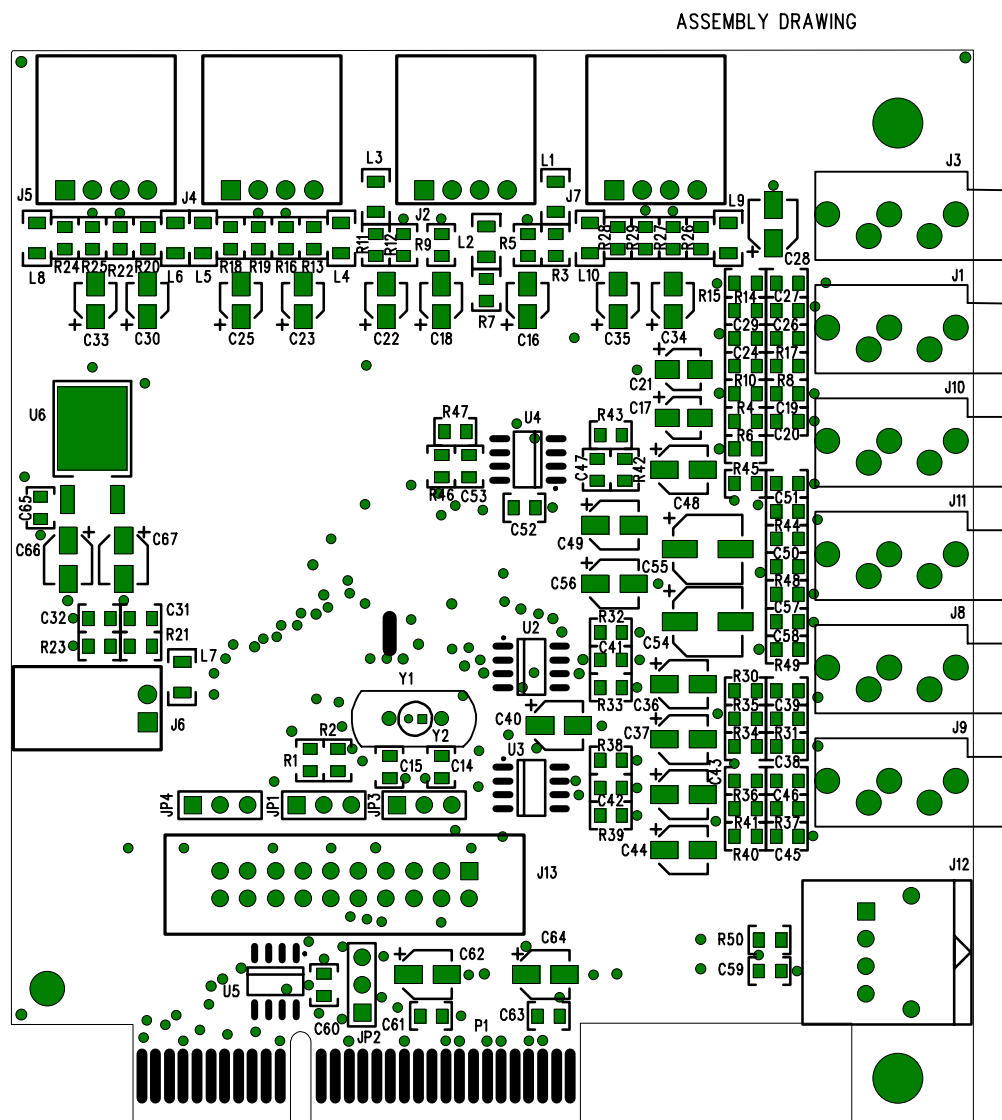

Figure 8. PCB Layout: Top Assembly Drawing

TOP LAYER-1

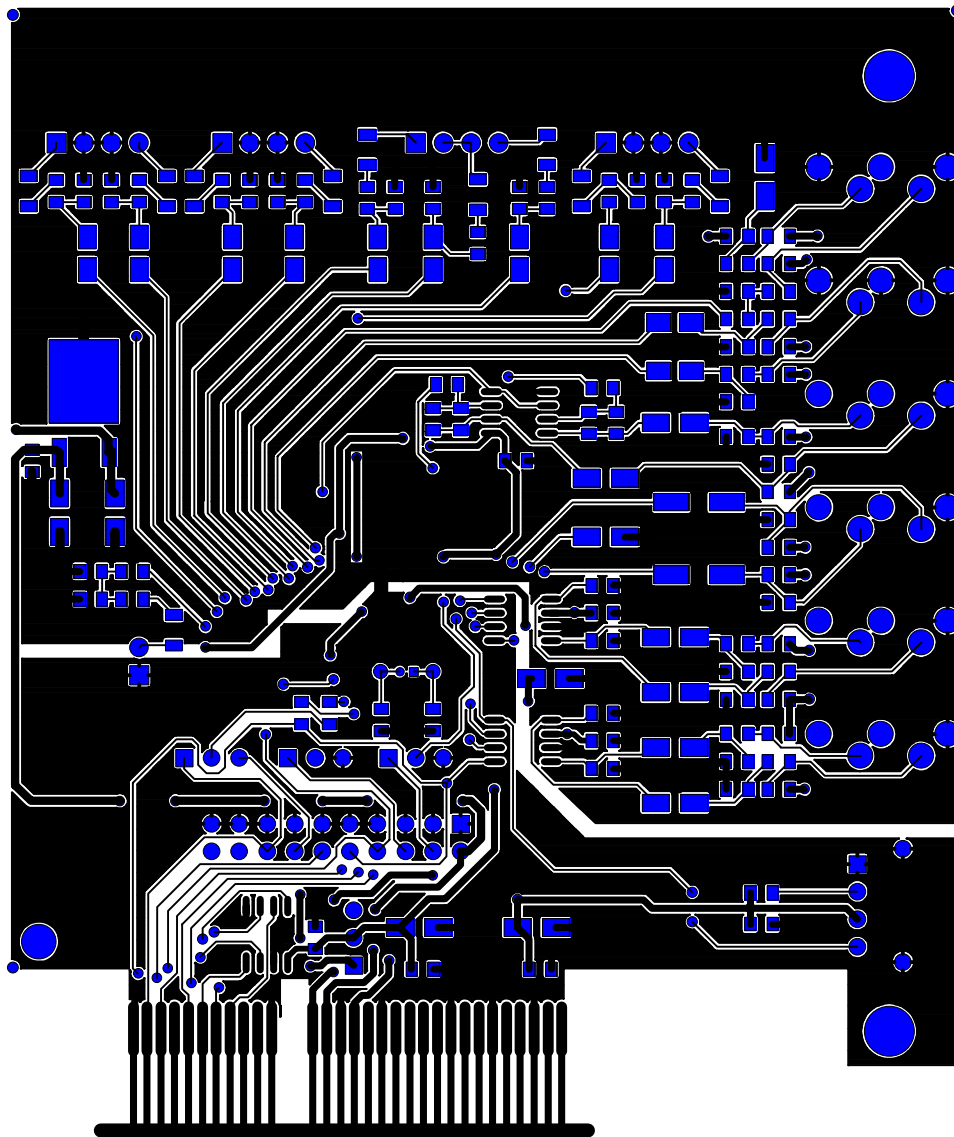

Figure 9. PCB Layout: Top Layer

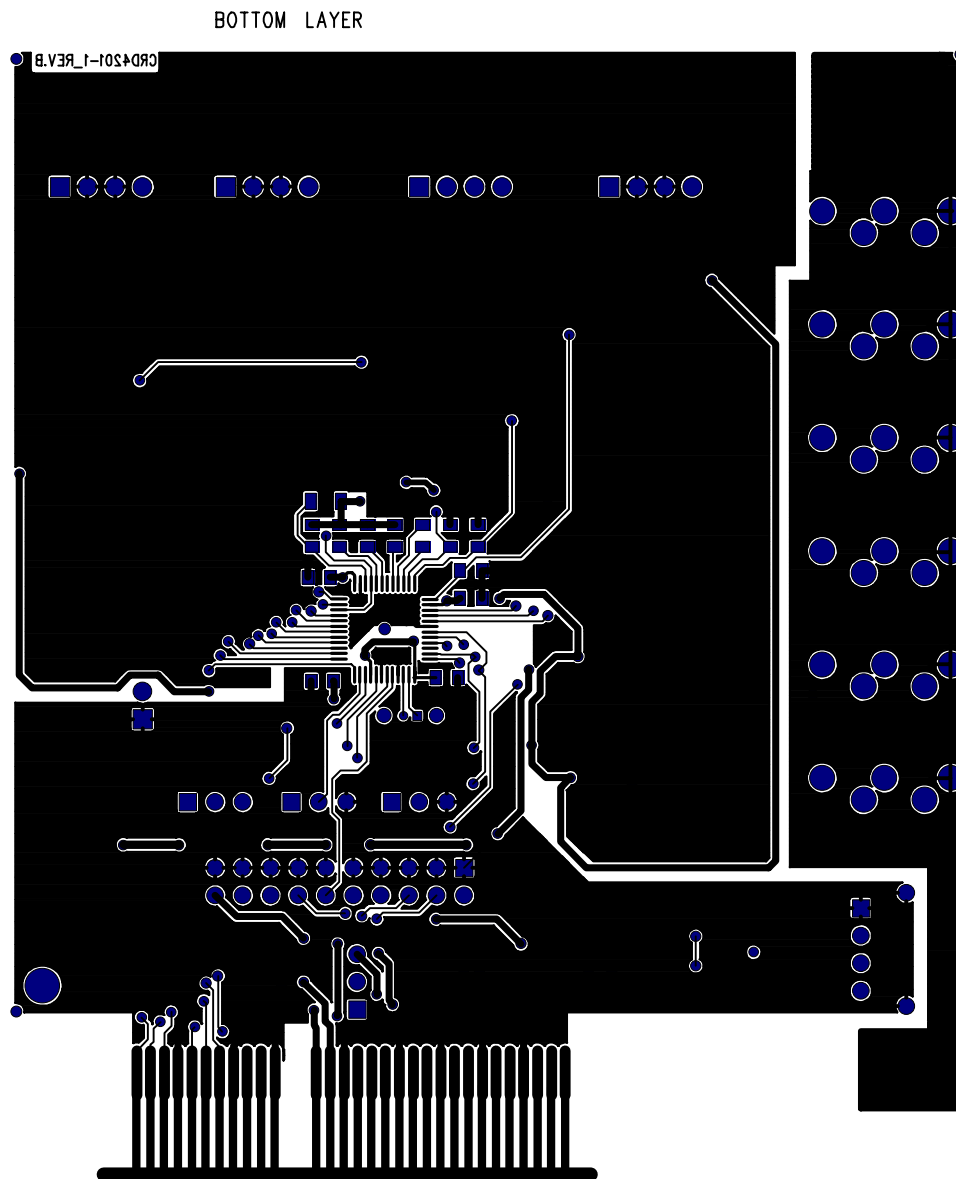

Figure 10. PCB Layout: Bottom Layer

ASSEMBLY DRAWING BOTTOM

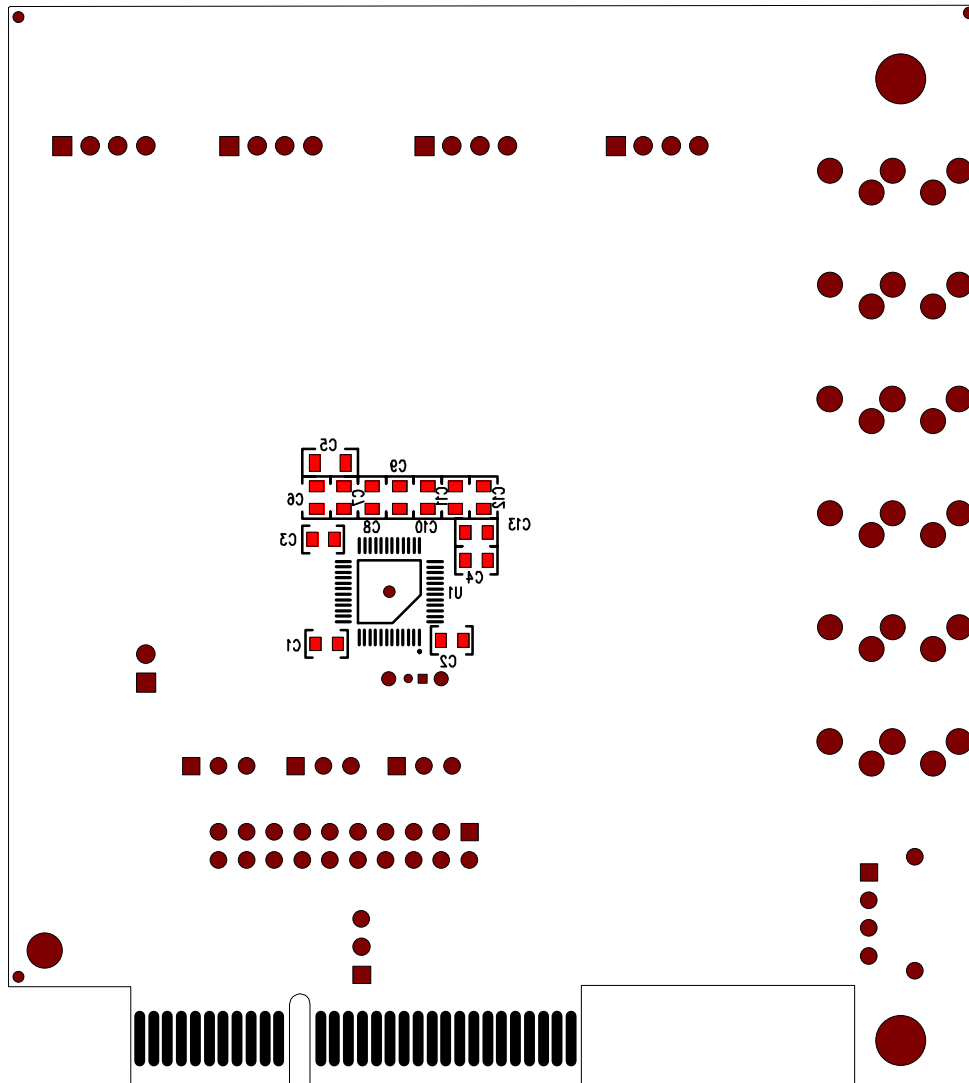

Figure 11. PCB Layout: Bottom Assembly

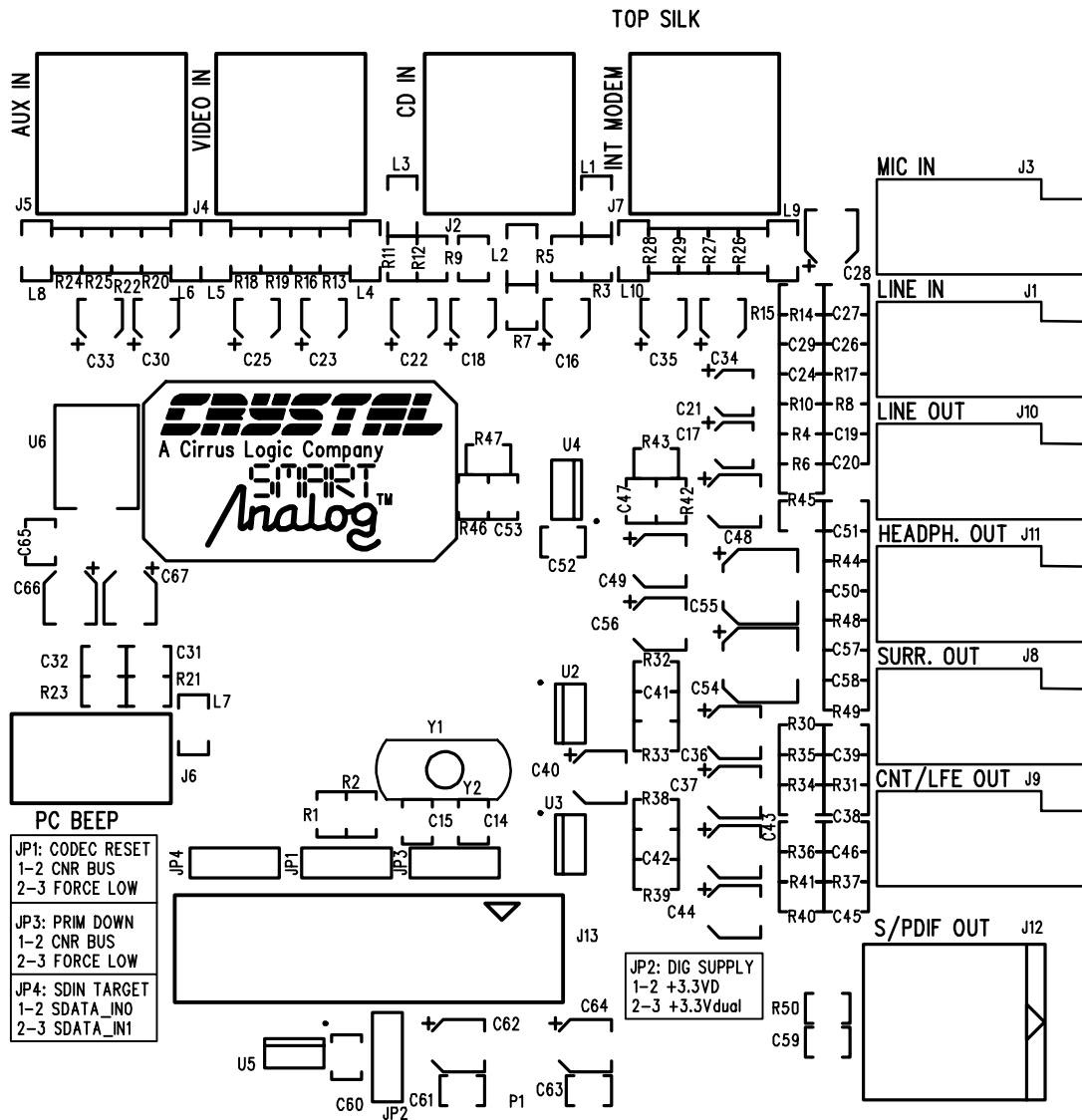

Figure 12. PCB Layout: Top Silkscreen

5. BILL OF MATERIALS

Item	Quantity	Reference	Manufacturer	Part Number	Description
1	13	C1,C2,C3,C4,C31,C41,C42,C52,C59,C60,C61,C63,C65	KEMET	C0805C104M5UAC	CAP, 0805, Z5U, .1uF, 20%, 50V
2	1	C5	KEMET	C1206C225M8VAC	CAP, 1206, Y5V, 2.2uF, 20%, 10V
3	3	C6,C24,C29	KEMET	C0805C104K5RAC	CAP, 0805, X7R, .1uF, 10%, 50V
4	6	C7,C8,C10,C11,C12,C13	KEMET	C0805C102K5GAC	CAP, 0805, C0G, 1000pF, 10%, 50V
5	1	C9	KEMET	C0805C103K5RAC	CAP, 0805, X7R, .01uF, 10%, 50V
6	4	C14,C15,C47,C53	KEMET	C0805C220K5GAC	CAP, 0805, C0G, 22pF, 10%, 50V
7	10	C16,C17,C21,C22,C23,C25,C30,C33,C34,C35	PANASONIC	ECE-V1VS2R2SR	CAP, SMT A, ELEC, 2.2uF, 20%, 35V
8	1	C18	PANASONIC	ECE-V1ES4R7SR	CAP, SMT A, ELEC, 4.7uF, 20%, 25V
9	4	C19,C20,C26,C27	KEMET	C0805C101J5GAC	CAP, 0805, COG, 100pF, 5%, 50V
10	12	C28,C36,C37,C40,C43,C44,C48,C49,C62,C64,C66,C67	PANASONIC	ECE-V1CA100R	CAP, SMT B, ELEC, 10uF, 20%, 16V
11	5	C32,C38,C39,C45,C46	KEMET	C0805C272K5RAC	CAP, 0805, X7R, 2700pF, 10%, 50V
12	4	C50,C51,C57,C58	KEMET	C0805C101J5GAC	CAP, 0805, C0G, 100pF, 5%, 50V
13	2	C54,C55	PANASONIC	ECE-V0GA221P	CAP, SMT D, ELEC, 220uF, 20%, 4V
14	1	C56	PANASONIC	ECE-V1HA010R	CAP, SMT B, ELEC, 1uF, 20%, 50V
15	4	JP1,JP2,JP3,JP4	SAMTEC	TSW-103-07-T-S	HDR, 3x1, 0.025" PIN, 0.1" CTR
16	1	J1	LZR ELECTRONICS	SJ372	CONN, 1/8" DOUBLE SW. STEREO PHONE JACK
17	4	J2,J4,J5,J7	MOLEX	70553-0003	HDR, 4X1, 0.025" PIN, 0.1" CTR, 15u" AU
18	1	J3	LZR ELECTRONICS	SJ374	CONN, 1/8" SINGLE SW. STEREO PHONE JACK
19	1	J6	MOLEX	70553-0036	HDR, 2X1, 0.025" PIN, 0.1" CTR, 150u" SN/PB
20	4	J8,J9,J10,J11	LZR ELECTRONICS	SJ373	CONN, 1/8" NON-SW. STEREO PHONE JACK
21	1	J12	TOSHIBA	TOTX173	CONN, OPTICAL TOSLINK TRANSMITTER
22	1	J13	AMP	103309-5	CONN, 10x2 RIBBON, MALE, STRAIGHT, SHROUDED
23	10	L1,L2,L3,L4,L5,L6,L7,L8,L9,L10	TDK	HF50ACB321611-T	IND, FBEAD, 1206, 31 @100MHz, 25%
24	1	P1	NONE	NONE	CNR BUS CONNECTOR
25	2	R1,R2	PHILIPS	9C08052A47R0J	RES, SO, 0805, 47, 5%, 1/10W, METAL FILM

26	18	R3,R4,R5,R6,R8,R10,R11,R12,R13,R16,R18,R19,R20,R22,R24,R25,R26,R27	PHILIPS	9C08052A6801F	RES, SO, 0805, 6.8K, 1%, 1/10W, METAL FILM
27	2	R9,R7	PHILIPS	9C08052A3401F	RES, SO, 0805, 3.4K, 1%, 1/10W, METAL FILM
28	1	R14	PHILIPS	9C08052A2201J	RES, SO, 0805, 2.2K, 5%, 1/10W, METAL FILM
29	1	R15	PHILIPS	9C08052A1501J	RES, SO, 0805, 1.5K, 5%, 1/10W, METAL FILM
30	1	R17	PHILIPS	9C08052A1000J	RES, SO, 0805, 100, 5%, 1/10W, METAL FILM
31	6	R21,R29,R34,R35,R40,R41	PHILIPS	9C08052A4702J	RES, SO, 0805, 47K, 5%, 1/10W, METAL FILM
32	1	R23	PHILIPS	9C08052A4701J	RES, SO, 0805, 4.7K, 5%, 1/10W, METAL FILM
33	1	R28	PHILIPS	9C08052A0R00J	RES, SO, 0805, 0, 5%, 1/10W, METAL FILM
34	4	R30,R31,R36,R37	PHILIPS	9C08052A5600J	RES, SO, 0805, 560, 5%, 1/10W, METAL FILM
35	4	R32,R33,R38,R39	PHILIPS	9C08052A2703J	RES, SO, 0805, 270K, 5%, 1/10W, METAL FILM
36	2	R42,R46	PHILIPS	9C08052A3302F	RES, SO, 0805, 33K, 1%, 1/10W, METAL FILM
37	2	R43,R47	PHILIPS	9C08052A2702F	RES, SO, 0805, 27K, 1%, 1/10W, METAL FILM
38	2	R44,R45	PHILIPS	9C08052A2203J	RES, SO, 0805, 220K, 5%, 1/10W, METAL FILM
39	2	R48,R49	PHILIPS	9C08052A1002J	RES, SO, 0805, 10K, 5%, 1/10W, METAL FILM
40	1	R50	PHILIPS	9C08052A8201J	RES, SO, 0805, 8.2K, 5%, 1/10W, METAL FILM
41	1	U1	CRYSTAL SEMI-COND.	CS4201-KQ	IC, TQFP, AC '97 2.1 SERIAL CODEC W/ HP AMP + SRC
42	2	U2,U3	CRYSTAL SEMI-COND.	CS4334-KS	IC, SO, SOIC8, ADC, STEREO
43	1	U4	MOTOROLA	MC34072D	IC, SO, SOIC8, 34072, SINGLE SUPPLY DUAL OP AMP
44	1	U5	ATMEL	AT24C02N-10SC-2.7	IC, SO, SOIC8, SERIAL EEPROM, 256 x 8, 2.7V
45	1	U6	MOTOROLA	MC78M05CDT	IC, SO, +5V REGULATOR, DPAK, 4%, 500mA
46	1	Y1	FOX	FS24.576	XTAL, 24.576MHz, HC49S, Fund Mode, Par Res

• **Notes** •

SMART
Analog™