

Low-Power High-Performance $\Delta\Sigma$ Modulators

Features

- Fourth-Order $\Delta\Sigma$ Architecture
- Clock Jitter Tolerant Architecture
- Input Voltage Range $5 V_{p-p}$ ($2.5 V_{diff}$)
- High Dynamic Range (SNR)
 - ♦ 124 dB @ 411 Hz Bandwidth
 - ♦ 121 dB @ 822 Hz Bandwidth
- Low Total Harmonic Distortion (THD)
 - ♦ -118 dB Typical, -112 dB Maximum
- Low Power Consumption
 - ♦ Normal Mode: 25 mW per Channel
 - ♦ Low Power Mode: 15 mW per Channel
- Small Footprint 24 Pin SSOP Package
- Single or Multi-Channel System Support
 - ♦ 1 Channel System; CS5371
 - ♦ 2 Channel System; CS5372
 - ♦ 3 Channel System; CS5371 + CS5372
 - ♦ 4 Channel System; CS5372 + CS5372
- Single or Dual Power Supply Configurations
 - ♦ $VA+ = +5 V$; $VA- = 0 V$; $VD = +3 V$ to $+5 V$
 - ♦ $VA+ = +2.5 V$; $VA- = -2.5 V$; $VD = +3 V$ to $+5 V$
 - ♦ $VA+ = +3 V$; $VA- = -3 V$; $VD = +3 V$

Description

The CS5371 and CS5372 are one and two channel high dynamic range, fourth-order $\Delta-\Sigma$ modulators intended for geophysical and sonar applications. Used in combination with the CS5376 digital filter, a unique high resolution A/D measurement system results.

The CS5371 and CS5372 provide higher dynamic range and lower total harmonic distortion than our industry standard CS5321 modulator, while consuming significantly less power per channel. The modulators generate an oversampled serial bit stream at 512 kbits per second when operated from a clock frequency of 2.048 MHz. The CS5371 and CS5372 are available in a small 24-pin SSOP package, providing exceptional performance in a very small footprint.

In normal mode (LPWR = 0, MCLK = 2.048 MHz), power consumption is 25 mW per channel, and in low power mode (LPWR = 1, MCLK = 1.024MHz), power consumption is 15 mW per channel. Each modulator can be independently powered down to 1 mW per channel, and by halting the input clock the modulators enter a micropower state using only 10 μ W per channel.

ORDERING INFORMATION

CS5371 - BS	-40 °C to +85 °C	24-pin SSOP
CS5372 - BS	-40 °C to +85 °C	24-pin SSOP

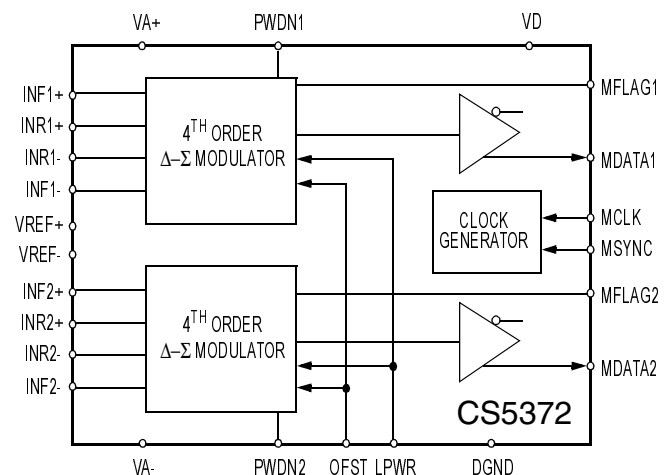
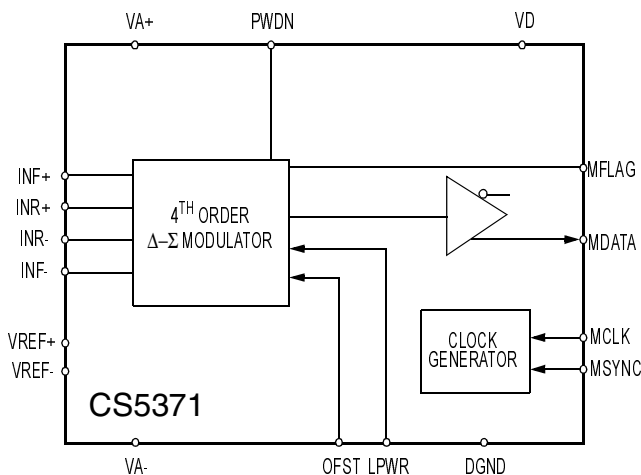

Preliminary Product Information

This document contains information for a new product. Cirrus Logic reserves the right to modify this product without notice.

TABLE OF CONTENTS

1. CHARACTERISTICS/SPECIFICATIONS.....	4
ANALOG CHARACTERISTICS	4
5.0 AND 3.0 V DIGITAL CHARACTERISTICS	6
ABSOLUTE MAXIMUM RATINGS	6
SWITCHING CHARACTERISTICS	7
2. GENERAL DESCRIPTION.	8
3. MODULATOR PERFORMANCE.....	10
3.1. Full Scale Signal Performance	10
3.2. Noise Performance	10
4. SIGNAL INPUTS	10
4.1. Differential Inputs - INR+/-, INF+/-	10
4.2. Anti-Alias Filters	11
4.3. Input Impedance	11
4.4. Maximum Signal Levels	12
5. INPUT OFFSET	12
5.1. Offset Enable - OFST.....	12
5.2. Offset Drift	12
6. VOLTAGE REFERENCE INPUTS	12
6.1. Voltage Reference Configurations	13
6.2. VREF Input Impedance.....	13
6.3. Gain Accuracy.....	14
6.4. Gain Drift.....	14
7. DIGITAL FILTER INTERFACE	14
7.1. Modulator Clock - MCLK.....	14
7.2. Modulator Data - MDATA.....	14
7.3. Modulator Sync - MSYNC	15
7.4. Modulator Flag - MFLAG.....	15
8. POWER MODES	15
8.1. Normal Power Mode	15
8.2. Low Power Mode - LPWR.....	16
8.3. Power Down Mode - PWDN.....	16
8.4. Micro Power Mode	16
9. POWER SUPPLY	16
9.1. Power Supply Configurations.....	16
9.2. Power Supply Bypassing	16
9.3. SCR Latch-up Considerations.....	16
9.4. DC-DC Converter Considerations.....	17
9.5. Power Supply Rejection	17
10. PIN DESCRIPTION - CS5371	18
11. PIN DESCRIPTION - CS5372	20
12. PACKAGE DIMENSIONS	22

Contacting Cirrus Logic Support

For a complete listing of Direct Sales, Distributor, and Sales Representative contacts, visit the Cirrus Logic web site at:
<http://www.cirrus.com/corporate/contacts/>

Preliminary product information describes products which are in production, but for which full characterization data is not yet available. Advance product information describes products which are in development and subject to development changes. Cirrus Logic, Inc. has made best efforts to ensure that the information contained in this document is accurate and reliable. However, the information is subject to change without notice and is provided "AS IS" without warranty of any kind (express or implied). No responsibility is assumed by Cirrus Logic, Inc. for the use of this information, nor for infringements of patents or other rights of third parties. This document is the property of Cirrus Logic, Inc. and implies no license under patents, copyrights, trademarks, or trade secrets. No part of this publication may be copied, reproduced, stored in a retrieval system, or transmitted, in any form or by any means (electronic, mechanical, photographic, or otherwise) without the prior written consent of Cirrus Logic, Inc. Items from any Cirrus Logic website or disk may be printed for use by the user. However, no part of the printout or electronic files may be copied, reproduced, stored in a retrieval system, or transmitted, in any form or by any means (electronic, mechanical, photographic, or otherwise) without the prior written consent of Cirrus Logic, Inc. Furthermore, no part of this publication may be used as a basis for manufacture or sale of any items without the prior written consent of Cirrus Logic, Inc. The names of products of Cirrus Logic, Inc. or other vendors and suppliers appearing in this document may be trademarks or service marks of their respective owners which may be registered in some jurisdictions. A list of Cirrus Logic, Inc. trademarks and service marks can be found at <http://www.cirrus.com>.

1. CHARACTERISTICS/SPECIFICATIONS

ANALOG CHARACTERISTICS Notes: $T_A = -40\text{ }^\circ\text{C}$ to $+85\text{ }^\circ\text{C}$; $V_{A+} = 2.5\text{ V} \pm 5\%$; $V_{A-} = -2.5\text{ V} \pm 5\%$; $V_D = 3\text{ V} \pm 5\%$; $DGND = 0\text{ V}$; $MCLK = 2.048\text{ MHz}$; $LPWR = 0$; $VREF_{+/-} = 2.5\text{ V}$ ($VREF_- = -2.5\text{ V}$; $VREF_+ = 0\text{ V}$); Devices are connected as shown in Figure 3, the System Connection Diagram, unless otherwise specified.

Parameter	Symbol	CS5371-BS / CS5372-BS			Unit
		Min	Typ	Max	
Specified Temperature Range	T_A	-40	-	+85	$^\circ\text{C}$
Dynamic Performance					
Dynamic Range (Note 1)	SNR				
OFST = 1					
0 Hz to 1644 Hz		-	109	-	dB
0 Hz to 822 Hz		-	121	-	dB
0 Hz to 411 Hz		121	124	-	dB
0 Hz to 206 Hz		-	127	-	dB
0 Hz to 103 Hz		-	130	-	dB
0 Hz to 51.5 Hz		-	133	-	dB
0 Hz to 25.75 Hz		-	136	-	dB
Total Harmonic Distortion (Note 2)	THD	-	-118	-112	dB
Intermodulation Distortion (Note 3)	IMD	-	-115	-	dB
DC Accuracy					
Channel to Channel Gain Variation	CGV	-	1	-	%
Full Scale Error (Note 4)	FSE	-	1	-	%
Full Scale Drift (Notes 4 and 5)	TC_{FS}	-	5	-	ppm/ $^\circ\text{C}$
Offset (Notes 4)	V_{ZSE}	-	1	-	mV
Offset after Calibration (Note 6)		-	± 1	-	μV
Offset Calibration Range (Note 7)		-	100	-	%F.S.
Offset Drift (Notes 4 and 5)	TC_{ZSE}	-	1	-	$\mu\text{V}/^\circ\text{C}$

- Notes:
- Dynamic Range defined as $20\log(\text{RMS full scale}) / (\text{RMS idle noise})$
 - Tested with full scale input signal of 31.25 Hz; OWR = 1000 sps; OFST = 0 or OFST = 1.
 - Characterized with input signals of 31.25 Hz and 52.63 Hz, each 6 dB down from full scale, OWR = 1000 sps.
 - Specification is for the parameter over the specified temperature range and is for the CS5371/CS5372 devices only and does not include the effects of external components.
 - Specifications are guaranteed by design and/or characterization.
 - The offset after calibration specification applies to the effective offset voltage for a full scale input to the CS5371/CS5372 modulator, but is measured from the output digital codes from the CS5376.
 - The CS5371/CS5372 offset calibration is performed digitally and includes full scale range. Calibration offsets greater than $\pm 5\%$ of full scale will begin to subtract from the dynamic range.

ANALOG CHARACTERISTICS (Continued)

Parameter	Symbol	Min	Typ	Max	Unit
Specified Temperature Range	T_A	-40	-	+85	°C
Input Characteristics					
Input Signal Frequencies (Note 8)	BW	DC	-	1644	Hz
Input Voltage Range (Note 9)	VIN	-	-	5	V _{p-p}
Input Over-range Voltage Tolerance (Note 9)	I _{OV} R	5	-	-	%F.S.
Input Signal plus Common Mode		VA-	-	VA+	V
Common Mode Rejection Ratio	CMRR	-	90	-	dB
Channel Crosstalk, CS5372 only	CXT	-	-120	-	dB
Voltage Reference Input					
VREF (VREF+) - (VREF-)		-	2.5	-	V
VREF Current		-	-	120	µA
Power Supplies					
DC Power Supply Currents (Note 10 and 11)					
LPWR = 0; MCLK = 2.048 MHz	Analog	VA	-	5.0	7.0 mA
	Digital	VD	-	0.1	0.2 mA
LPWR = 1; MCLK = 1.024 MHz	Analog	VA	-	3.0	4.5 mA
	Digital	VD	-	0.1	0.2 mA
Power Down	P_D				
CS5371	PWDN = 1		-	1	- mW
	PWDN = 1, MCLK = 0		-	10	- µW
CS5372	PWDN1 or PWDN2 = 1		-	25	- mW
	PWDN1 = PWDN2 = 1		-	1	- mW
	PWDN1 = PWDN2 = 1; MCLK = 0		-	10	- µW
Power Supply Rejection DC - 128 kHz (Note 12)	PSRR	-	90	-	dB

- Notes:
8. The upper bandwidth limit is determined by the CS5376 digital filter. A simple single pole anti-alias filter with a -3 dB frequency at (MCLK / 256) should be placed in front of each channel.
 9. The input voltage range is for the configuration depicted in Figure 3, the System Connection Diagram, and applies to signal frequencies from DC to the stop-band frequency selected in the CS5376.
 10. Per channel. All outputs unloaded. All digital inputs forced to VD or GND respectively.
 11. In Low Power Mode LPWR = 1, the Master Clock MCLK is reduced to 1.024 MHz. This reduces the signal bandwidth by a factor of 2.
 12. Tested with a 100 mVp-p sine wave applied separately to each supply.

5.0 AND 3.0 V DIGITAL CHARACTERISTICS Notes: $T_A = 25\text{ }^\circ\text{C}$; $V_{A+}, V_D = 5\text{ V} \pm 5\%$ or $3\text{ V} \pm 5\%$; $AGND, DGND = 0\text{ V}$; All voltages with respect to $DGND$.

Parameter	Symbol	Min	Typ	Max	Unit
High-Level Input Voltage	V_{IH}	$0.6 * V_D$	-	V_D	V
Low-Level Input Voltage	V_{IL}	0.0	-	0.8	V
High-Level Output Voltage	V_{OH}	$(V_D) - 1.0$	-	-	V
Low-Level Output Voltage	V_{OL}	-	-	0.4	V
Input Leakage Current	I_{in}	-	± 1	± 10	μA
3-State Leakage Current	I_{OZ}	-	-	± 10	μA
Digital Output Pin Capacitance	C_{out}	-	9	-	pF

ABSOLUTE MAXIMUM RATINGS Notes: $DGND = 0\text{ V}$

Parameter	Symbol	Min	Typ	Max	Unit	
DC Power Supplies (Note 13 and 14)	Positive Digital Positive Analog Negative Analog	V_D V_{A+} V_{A-}	-0.3 -0.3 +0.3	- - -	+6.0 +6.0 -3.3	V V V
Input Current, Any Pin Except Supplies (Note 15 and 16)	I_{IN}	-	-	± 10	mA	
Input Current, Supplies (Note 16)	I_{IN}	-	-	± 50	mA	
Output Current	I_{OUT}	-	-	± 25	mA	
Power Dissipation (Note 17)	PDN	-	-	500	mW	
Analog Input Voltage	All Analog Pins	V_{INA}	-0.3	-	$(V_{A+}) + 0.3$	V
Digital Input Voltage	All Digital Pins	V_{IND}	-0.3	-	$(V_D) + 0.3$	V
Ambient Operating Temperature	T_A	-40	-	85	$^\circ\text{C}$	
Storage Temperature	T_{stg}	-65	-	150	$^\circ\text{C}$	

- Notes: 13. V_{A+} and V_{A-} must satisfy $\{(V_{A+}) - (V_{A-})\} < +6.6\text{ V}$.
 14. V_D and V_{A-} must satisfy $\{(V_D) - (V_{A-})\} < +7.6\text{ V}$.
 15. Includes continuous over-voltage conditions at the analog input (AIN) pins.
 16. Transient current of up to 100 mA can be safely tolerated without SCR latch-up.
 17. Total power dissipation, including all input and output currents.

SWITCHING CHARACTERISTICS Notes: $T_A = -40\text{ }^\circ\text{C}$ to $+85\text{ }^\circ\text{C}$; $V_{A+} = +2.5\text{ V} \pm 5\%$ $V_{A-} = -2.5\text{ V} \pm 5\%$; $V_D = 3\text{ V} \pm 5\%$; Inputs: Logic 0 = 0 V, Logic 1 = V_D ; $C_L = 50\text{ pF}$

Parameter		Symbol	Min	Typ	Max	Unit
MCLK Frequency	(Note 18)	f_c	0.1	2.048	2.2	MHz
MCLK Duty Cycle			40	-	60	%
MCLK Jitter (In-band, Aliased in-band)			-	-	300	ps
MCLK Jitter (Out-of-band)			-	-	1	ns
Rise Times:	Any Digital Input (Note 19)	t_{risein}	-	-	50	ns
	Any Digital Output	$t_{riseout}$	-	50	100	ns
Fall Times:	Any Digital Input (Note 19)	t_{fallin}	-	-	50	ns
	Any Digital Output	$t_{fallout}$	-	50	100	ns
MSYNC Setup Time to MCLK falling	(Note 20)	t_{mss}	20	-	-	ns
MSYNC Hold Time after MCLK falling		t_{msh}	20	-	-	ns
MCLK rising to Valid MFLAG		t_{mfh}	-	35	65	ns
MCLK rising to Valid MDATA		t_{mdv}	-	60	90	ns

Notes: 18. If MCLK is removed, the CS5372 enters a micro power state.

19. Excludes MCLK input, MCLK should be driven with a signal having rise/fall times of 25 ns or faster.

20. MSYNC latched on MCLK falling edge, data output on next MCLK rising edge.



Figure 1. Rise and Fall Times

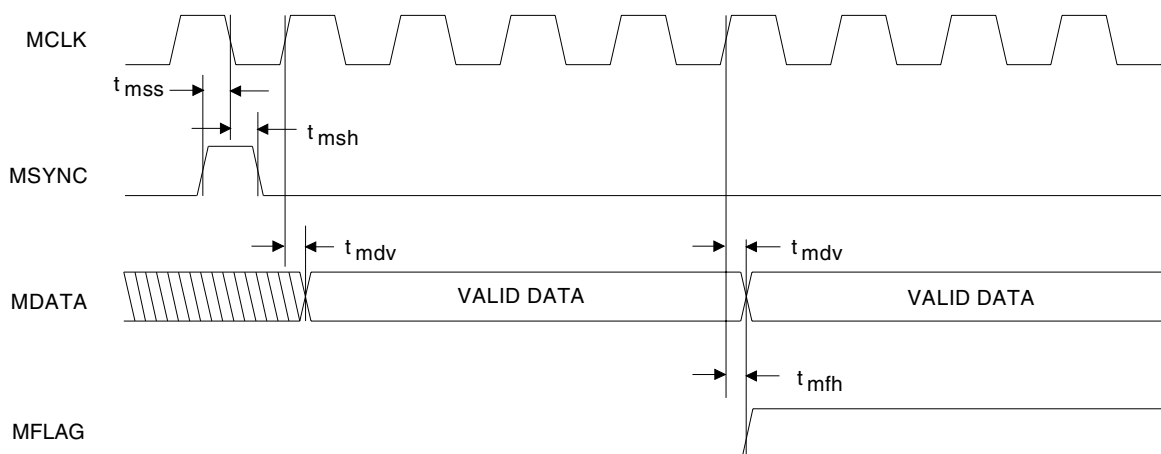

Figure 2. CS5372 Interface Timing

2. GENERAL DESCRIPTION.

The CS5371 and CS5372 are one and two channel fourth-order Δ - Σ modulators, optimized for extremely high resolution measurement of signals between DC and 1644 Hz. They are designed to be used with the CS5376 low power multi-channel decimation filter. Figure 3 on page 8 shows a four-channel system connection diagram for two CS5372 and one CS5376.

High Performance

The CS5371/CS5372 modulators have exceptional performance characteristics. Modulator dynamic range (SNR) is 124 dB over a 411 Hz bandwidth, with total harmonic distortion (THD) of -118 dB.

Low Power Consumption

The CS5371/CS5372 modulators have very low power consumption. Power consumption is only 25 mW per channel in normal mode (LPWR=0, MCLK=2.048 MHz), and 15 mW per channel in low power mode (LPWR=1, MCLK=1.024 MHz).

An independently selectable power-down mode (PWDN=1) can be used to disable a modulator and reduces its power consumption to 1 mW. If MCLK is then halted (MCLK=0), the modulator enters a micropower state using only 10 μ W per channel.

Small Package Size

The CS5371/CS5372 modulators are available in a very small 24-pin SSOP package approximately 8 mm x 8 mm in size. The CS5372 has two modulator channels per package to increase board layout density even further.

Multi-Channel System Support

Combining the CS5371 and CS5372 modulators with the CS5376 digital filter permits multiple channel system configurations to be supported.

- 1 Channel - CS5371, CS5376
- 2 Channel - CS5372, CS5376
- 3 Channel - CS5371, CS5372, CS5376
- 4 Channel - CS5372, CS5372, CS5376

Differential Analog Signal Inputs

The CS5371/CS5372 modulators have differential analog inputs capable of measuring signals up to 5.0 V peak-to-peak (2.5 V fully differential) when using a 2.5 V voltage reference. The inputs will tolerate a 5% over-range voltage and continue operating at full specification.

Digital Filter Interface

The CS5371/CS5372 modulators are designed to operate with the CS5376 digital filter. The CS5376 generates the modulator clock and synchronization signal inputs (MCLK and MSYNC), while receiving the modulator data and over-range flag outputs (MDATA and MFLAG). The modulators produce an oversampled Δ - Σ serial bit stream at 512 kbits per second when operated from a 2.048 MHz modulator clock.

Multiple Power Supply Configurations

The CS5371/CS5372 modulators support multiple power supply configurations. They can run from single or dual supplies in the following configurations:

- ♦ VA+ = +5V; VA- = 0V; VD = +3V to +5V
- ♦ VA+ = +2.5V; VA- = -2.5V; VD = +3V to +5V
- ♦ VA+ = +3V; VA- = -3V; VD = +3V

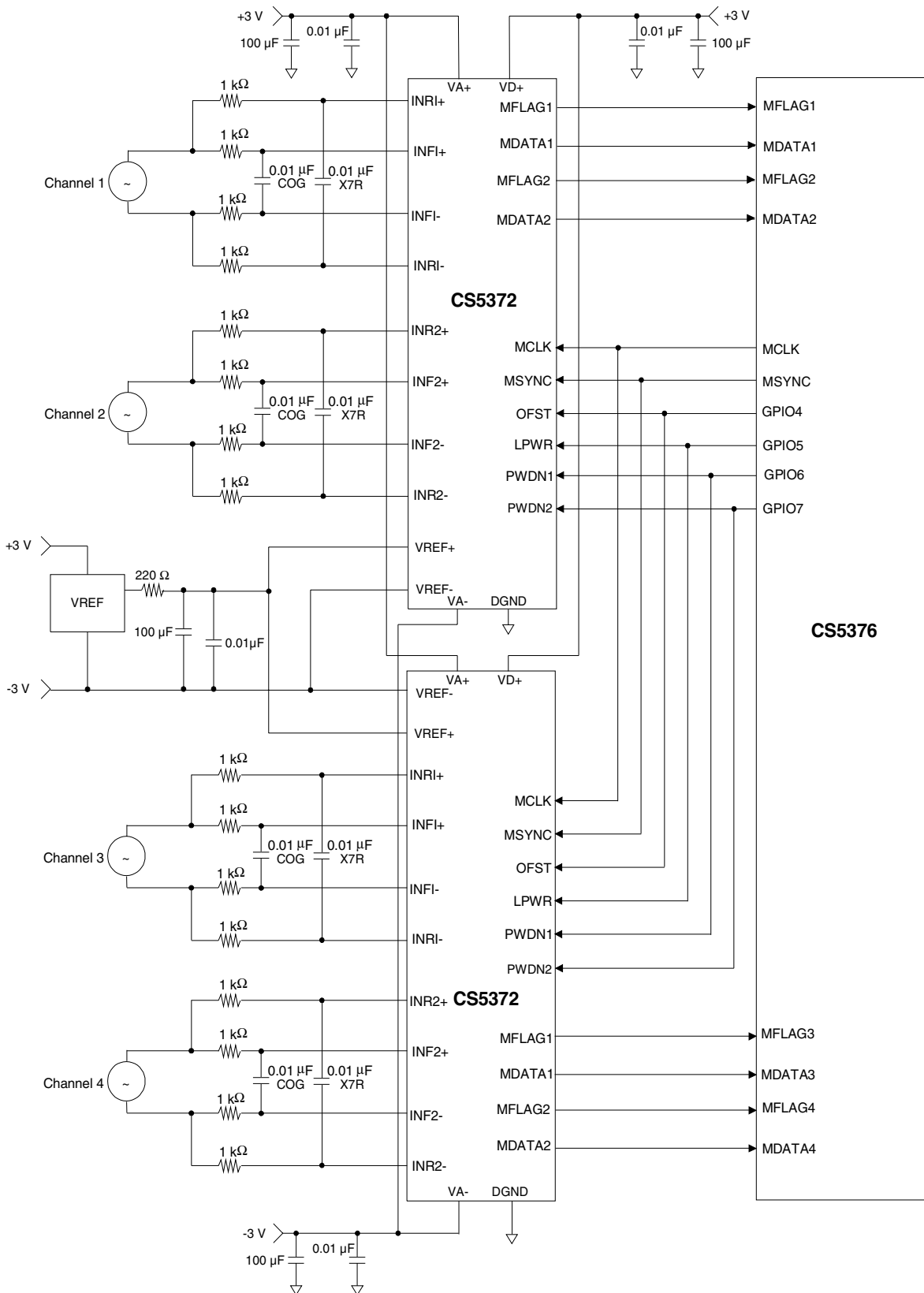

Figure 3. System Connection Diagram

3. MODULATOR PERFORMANCE

Figures 4 and 5 illustrate the spectral performance of the CS5371/CS5372 modulators when combined with the CS5376 digital filter. The plots were created from ten averaged 1024 point FFTs.

3.1. Full Scale Signal Performance

Figure 4 illustrates the full-scale signal performance of the CS5371/CS5372 modulators and CS5376 digital filter using a 31.25 Hz input signal and a 1000 sps output word rate. The outstanding full-scale signal characteristics of the CS5371/CS5372 modulators are shown, with no harmonic components exceeding -120 dB. Analysis of this data set yields a signal-to-noise ratio (SNR) of 124.0 dB and a signal-to-distortion ratio (SDR) of 119.0 dB. Note that the full-scale signal peak in Figure 4 shows a slightly reduced amplitude due to spectral smearing associated with the FFT windowing function, and is a purely digital phenomenon.

3.2. Noise Performance

Figure 5 illustrates the noise performance of the CS5371/CS5372 modulators and CS5376 digital filter using a 31.25 Hz -24 dB input signal and a

1000 sps output word rate. The outstanding noise characteristics of the CS5371/CS5372 modulators are shown, with the averaged noise components consistently below the -150 dB level. Analysis of this data set yields a dynamic range of 124.7 dB. Note that the 0.7 dB variation between the signal-to-noise calculation in Figure 4 and the dynamic range calculation in Figure 5 is not modulator dependent and results from jitter in the test signal generator when producing a full scale output, as evidenced by the skirt surrounding the signal peak below the -140 dB level in Figure 4.

4. SIGNAL INPUTS

The CS5371/CS5372 modulators use a switched capacitor architecture for the analog signal inputs, which has increased jitter tolerance relative to continuous time signal input stages.

4.1. Differential Inputs - INR+/-, INF+/-

The analog signal inputs are differential and use four pins: INR+, INR-, INF+, and INF-. The positive inputs, INR+ and INF+, are connected to the positive half of the differential signal, while the negative inputs, INR- and INF-, are connected to

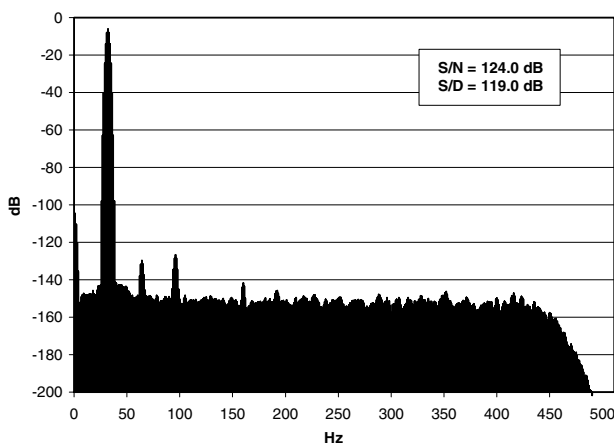

Figure 4. 1024 Point FFT plot with a 31.25 Hz input at Full Scale, ten averages

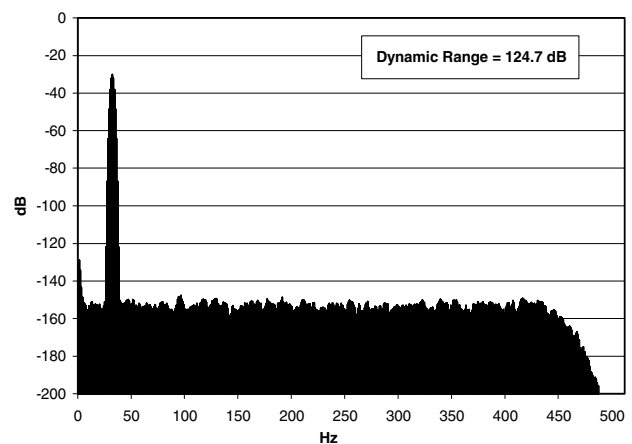

Figure 5. 1024 Point FFT plot with a 31.25 Hz input at -24 dB, ten averages

the negative half. The INR+ and INR- pins are switched capacitor ‘rough charge’ inputs for the INF+ and INF- fine input pins.

The full scale analog signal span is defined by the voltage applied across the VREF+ and VREF- pins. A 2.5 volt reference input sets full scale signals as 5 volts peak-to-peak, or 2.5 volts fully differential. Differential inputs increase the dynamic range of small signals, reducing the gain requirements for input amplifier stages by a factor of two relative to single ended analog inputs.

4.2. Anti-Alias Filters

The CS5371/CS5372 modulator inputs must be bandwidth limited to ensure modulator loop stability and to prevent aliased high-frequency signals. The modulators are 4th order and so are conditionally stable, and can be adversely affected by high amplitude out-of-band signals. Also, aliasing effects degrade modulator performance if the analog inputs are not bandwidth limited since out-of-band signals can appear in the measurement bandwidth. The use of a simple single pole low-pass anti-alias filter on the differential inputs ensures out-of-band signals are eliminated.

Anti-alias filtering may be accomplished actively in an amplifier stage ahead of the CS5371/CS5372 modulator, or passively using an RC filter across the differential rough and fine analog inputs. An RC filter is recommended, even when using an amplifier stage, as it minimizes the ‘charge kick’ that the driving amplifier sees as switched capacitor sampling is performed.

The -3 dB corner of the input anti-alias filter should be set to the internal modulator sampling clock divided by 64. The modulator sampling clock is a division by 4 of the modulator clock, MCLK. With MCLK=2.048 MHz the modulator sampling clock is 512 kHz, requiring an input filter with a -3 dB corner at 8 kHz.

$$\text{MCLK Frequency} = 2.048 \text{ MHz}$$

$$\text{Sampling Frequency} = \text{MCLK} / 4 = 512 \text{ kHz}$$

$$\text{-3 dB Filter Corner} = \text{Sample Freq} / 64 = 8 \text{ kHz}$$

$$\text{RC filter} = 8 \text{ kHz} = 1 / [2\pi * (2 * R_{\text{diff}}) * C_{\text{diff}}]$$

It should be noted that when using low power mode (LPWR=1 and MCLK=1.024 MHz) the modulator sampling clock is 256 kHz, so the -3 dB filter corner should be scaled down to 4 kHz.

$$\text{MCLK Frequency} = 1.024 \text{ MHz}$$

$$\text{Sampling Frequency} = \text{MCLK} / 4 = 256 \text{ kHz}$$

$$\text{-3 dB Filter Corner} = \text{Sample Freq} / 64 = 4 \text{ kHz}$$

$$\text{RC filter} = 4 \text{ kHz} = 1 / [2\pi * (2 * R_{\text{diff}}) * C_{\text{diff}}]$$

Figure 3 illustrates the CS5372/CS5376 system connections with input anti-alias filter components. Filter components on the rough and fine pins should be identical values for optimum performance, with the capacitor values a minimum of 0.01 μF . The rough input can use either X7R or C0G capacitors, while the fine input requires C0G type capacitors for optimal linearity. Using X7R capacitors on the fine inputs will degrade signal to distortion performance up to 8 dB.

4.3. Input Impedance

Due to the dynamic switched-capacitor input architecture the input current required from the analog signal source, and thus the input impedance of the analog input pins, changes any time MCLK is changed. The input impedance of the rough charge inputs, INR+ and INR-, is $[1 / (f * C)]$ where f is the modulator clock frequency, MCLK, and C is the internal sampling capacitor. A 2.048 MHz modulator clock yields a rough input impedance of approximately $[1 / (2.048 \text{ MHz}) * (20 \text{ pF})]$, or about 24 kohms.

Internal to the modulator the rough charge inputs pre-charge the sampling capacitor used by the fine inputs, therefore the effective input impedance of the fine inputs is orders of magnitude above the impedance of the rough inputs.

4.4. Maximum Signal Levels

The CS5371/CS5372 modulators are 4th order and are therefore conditionally stable, and may go into an oscillatory condition if the analog inputs over-range beyond full scale by more than 5%. If an unstable condition is detected, the modulators collapse to a 1st order system until loop stability is achieved. During this time, the MFLAG pin transitions from low to high signaling the CS5376 digital filter to set an error bit in the digital output word. The analog input signal must be reduced to within the full scale range of the converter for at least 32 MCLK cycles for the modulators to recover from an unstable condition.

5. INPUT OFFSET

The CS5371/CS5372 modulators are Δ - Σ type and so can produce 'idle tones' in the passband when the input signal is a steady state DC signal within about ± 50 mV of the common mode input voltage. Idle tones result from patterns in the output bit-stream and appear in the measurement spectrum about -135 dB down from full scale.

Idle tones can be eliminated by adding 100 mV or more of differential DC offset to the modulator inputs. The added offset should be applied differentially to the inputs, common mode offsets do not affect idle tones.

5.1. Offset Enable - OFST

If the analog inputs are within ± 50 mV of the common mode voltage when no signal is present, the OFST pin can be used to eliminate idle tones. When OFST=1, +100 mV of differential offset is added to the modulator analog inputs to push the idle tones out of the measurement bandwidth. Care should be taken that when OFST is active, offset voltages generated by external circuitry do not negate the internally added offset.

5.2. Offset Drift

Offset drift characteristics vary from part to part and with changes in the power supply voltages. If the CS5371/CS5372 is used in precision DC measurement applications where offset drift is to be minimized, the power supplies should be well regulated.

For the lowest offset drift, the CS5371/CS5372 modulators should operate with an MCLK of 2.048 MHz. The offset drift rate is inversely proportional to clock frequency, with slower modulator clock rates exhibiting more offset drift. Operating from an MCLK of 1.024 MHz results in twice the offset drift rate compared to an MCLK of 2.048 MHz.

Because offset drift is not linear with temperature, an exact drift rate per $^{\circ}\text{C}$ cannot be specified. The CS5371/CS5372 modulators will exhibit approximately 5 ppm/ $^{\circ}\text{C}$ of offset drift operating with an MCLK of 2.048 MHz.

6. VOLTAGE REFERENCE INPUTS

The CS5371/CS5372 modulators are designed to operate with a 2.5 V voltage reference applied across the VREF+ and VREF- pins to set the full scale signal range of the analog inputs. A 2.5 V voltage reference results in the highest dynamic range and best signal-to-noise performance, though smaller reference voltages may be used. When the CS5371/CS5372 modulators are operated with a 2.5 V reference, the analog inputs measure full scale signals of 5 volts peak-to-peak, or 2.5 volts differential.

In a single supply power configuration the voltage reference output should be connected to the VREF+ pin with the VREF- pin connected to ground. In a dual supply power configuration the voltage reference should be powered from the VA+ and VA- supplies, with the modulator VREF+ pin connected to the voltage reference output and the

VREF- pin connected to VA-. Because most 2.5 V voltage references require a power supply voltage greater than 3 V to operate, when powering the voltage reference from dual ± 2.5 V or ± 3.0 V supplies the reference voltage into the VREF+ pin is defined relative to the VA- supply.

The selected voltage reference should produce less than 1 μ Vrms of noise in the measurement bandwidth on the VREF+ pin. The CS5376 digital filter output word rate selection determines the bandwidth over which voltage reference noise affects the CS5371/CS5372 modulator dynamic range.

6.1. Voltage Reference Configurations

For a 2.5 V reference, the Linear Technology LT1019-2.5 voltage reference yields low enough noise if the output is filtered with a low pass RC fil-

ter as shown in Figure 6. The filtered version in Figure 6 is acceptable for most spectral measurement applications, but a buffered version with lower source impedance, Figure 7, may be preferred for DC measurement applications. The configuration shown in Figure 7 can use a Linear Technology LT1077 or similar low voltage op-amp to buffer the voltage reference output.

6.2. VREF Input Impedance

Due to the dynamic switched-capacitor input architecture the input current required from the voltage reference, and thus the input impedance of the modulator VREF+ pin, will change any time MCLK is changed. The input impedance of the voltage reference input is calculated similar to the analog signal input impedance as $[1 / (f * C)]$ where f is the modulator clock frequency, MCLK,

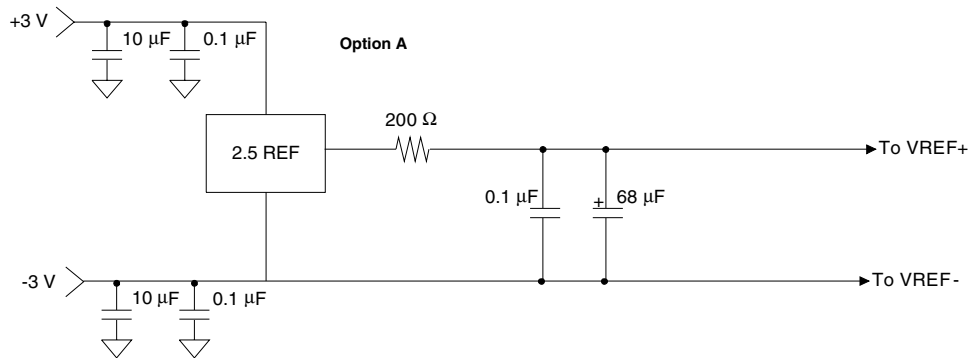

Figure 6. 2.5 Voltage Reference Option A

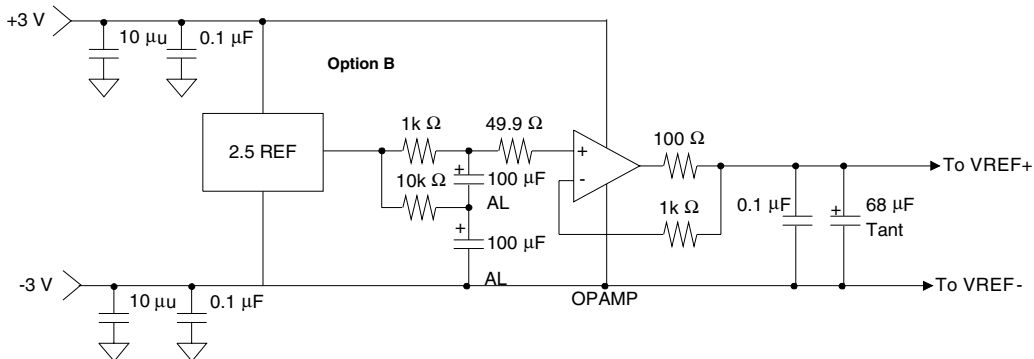

Figure 7. 2.5 Voltage Reference Option B

and C is the internal sampling capacitor. A 2.048 MHz MCLK yields a voltage reference input impedance of approximately $[1 / (2.048 \text{ MHz}) * (20 \text{ pF})]$, or about 24 kohms.

6.3. Gain Accuracy

Gain accuracy of the CS5371/CS5372 modulators is affected by variation of the voltage reference input. A change in the voltage reference input impedance due to a change in MCLK could affect gain accuracy when using the higher source impedance configuration of Figure 6. The VREF+ pin input impedance and the external low-pass filter resistor create a resistive voltage divider for the output reference voltage, reducing the effective voltage reference input. If gain error is to be minimized, especially when MCLK is to be changed, the voltage reference should have a low output impedance to minimize the effect of the resistive voltage divider. The buffered voltage reference configuration of Figure 7 offers lower output impedance and more stable gain characteristics.

6.4. Gain Drift

Gain drift of the CS5371/CS5372 modulators due to temperature is around 5 ppm/°C, and does not include the temperature drift characteristics of the external voltage reference. Gain drift is not affected by the modulator sample rate or by power supply variations.

7. DIGITAL FILTER INTERFACE

The CS5371/CS5372 modulators are designed to operate with the CS5376 digital filter. The CS5376 generates the modulator clock and synchronization signal inputs (MCLK and MSYNC), while receiving the modulator data and over-range flag outputs (MDATA and MFLAG). The modulators produce an oversampled Δ - Σ serial bit stream at 512 kbits per second when operated from a 2.048 MHz modulator clock.

7.1. Modulator Clock - MCLK

For proper operation, the CS5371/CS5372 modulators must be provided with a CMOS compatible clock on the MCLK pin. MCLK is internally divided by four to generate the modulator sampling clock. MCLK must have less than 300 ps of in-band jitter to maintain full performance specifications.

When used with the CS5376 digital filter, MCLK is automatically generated and is typically 2.048 MHz or 1.024 MHz. MCLK can be generated by other means, using a crystal oscillator for example, and can run any rate between 100 kHz and 2.2 MHz. If MCLK is disabled, the modulators are placed into a micro-power state. They are equipped with loss of clock detection circuitry to force power down if MCLK is removed.

The choice of MCLK frequency affects the performance of the CS5371/CS5372 modulators. They exhibit the best dynamic range (SNR) performance with faster MCLK rates because of increased oversampling of the analog input signal. The modulators exhibit the best total harmonic distortion (THD) performance with slower MCLK rates because slower sampling allows more time to settle the analog input signal.

7.2. Modulator Data - MDATA

The CS5371/CS5372 modulators output a Δ - Σ serial bitstream to the MDATA pin, with a one's density proportional to the amplitude of the analog input signal and a bit rate determined by the modulator sampling clock. The modulator sampling clock is a divide by four of MCLK, so for a 2.048 MHz MCLK the modulator sampling clock and MDATA output bit rate will be 512 kHz.

The MDATA output has a one's density defined as nominal 50% for no signal input, 86% for positive full scale, and 14% for negative full scale. It has a maximum positive over-range capability to 93% and a maximum negative over-range capability to

7%. The one's density of the MDATA output is defined as the ratio of '1' bits to total bits in the serial bitstream output, i.e. an 86% one's density has, on average, a '1' value in 86 of every 100 output data bits.

When operated with the CS5376 digital filter, the full scale 24-bit output codes range from 0x5FFFFFF (decimal 6,291,455) to 0xA00001 (decimal -6,291,455).

Modulator Input Signal	CS5376 Filter Output Code	
	HEX	Decimal
> + (VREF + 5%)	Error Flag Possible	
≈ + (VREF + 5%)	64CCCC	+6606028
+VREF	5FFFFFF	+6291455
0V	000000	0
-VREF	A00001	-6291455
≈ - (VREF + 5%)	9B3334	-6606028
> - (VREF + 5%)	Error Flag Possible	

Table 1. Output coding for the CS5371/CS5372 and CS5376 combination

Note that for a full scale input signal, $5 V_{p-p}$ ($2.5 V_{diff}$) with $VREF=2.5 V$, the CS5371/CS5372 and CS5376 chip set does not output a maximum 24-bit 2's complement digital code of 0x7FFFFFF (digital 8,388,607), but instead a lower scaled value to allow over-range capability. The CS5376 converts to full performance specification up to a positive over-range value of 0x64CCCC (decimal 6,606,028) and down to a negative over-range value of 0x9B3334 (decimal -6,606,028).

7.3. Modulator Sync - MSYNC

To synchronize the analog sampling instant and timing of the digital output bitstream, the CS5371/CS5372 modulators use an MSYNC signal. When using the CS5376 digital filter, MSYNC is automatically generated from a SYNC signal input from the external system.

The MSYNC input is rising edge triggered and resets the internal MCLK counter-divider so the analog sampling instant occurs during a consistent MCLK phase. It also sets the MDATA output timing so the bitstream can be properly sampled by the CS5376 digital filter input.

7.4. Modulator Flag - MFLAG

The CS5371/CS5372 modulators are 4th order $\Delta-\Sigma$ and are therefore conditionally stable. The modulators may go into an oscillatory condition if the analog inputs are over-ranged more than 5% past either positive or negative full scale.

If an unstable condition is detected, the modulators collapse to a 1st order system until loop stability is achieved. During this time, the MFLAG pin transitions from low to high to signal an error condition. The analog input signal must be reduced to within the full scale range for at least 32 MCLK cycles for the modulator to recover from an unstable condition.

The MFLAG output connects to a dedicated input on the CS5376 digital filter, causing an error bit to be set in the status portion of the digital output data word when detected.

8. POWER MODES

Four power modes are available when using the CS5371/CS5372 modulators. Normal power and low power modes are operational modes, power down and micro power modes are non-operational standby modes.

8.1. Normal Power Mode

The normal operational mode for the modulators, $LPWR=0$ and $MCLK=2.048 MHz$, provides the best performance with power consumption of 25 mW per channel. This power mode is recommended when maximum conversion accuracy is required.

8.2. Low Power Mode - LPWR

The modulators have a low-power operational mode, LPWR=1 and MCLK=1.024 MHz, that reduces power consumption to 15 mW per channel at the expense of 3 dB of dynamic range. This operational mode is recommended when minimizing power is more important than maximizing dynamic range.

When operated with LPWR=1, the modulator sampling clock (MCLK / 4) must be restricted to rates of 256 kHz or less, which requires MCLK to run at 1.024 MHz or less. Operating in low power mode with modulator sample rates greater than 256 kHz will significantly degrade total harmonic distortion performance.

8.3. Power Down Mode - PWDN

The modulators have a power down mode, PWDN=1 and MCLK=Active, that disables the operation of the selected modulator channel and reduces its power consumption to 1 mW. Each modulator has an independent power down pin, PWDN on the CS5371 and PWDN1, PWDN2 on the CS5372. Note that when the modulators are powered down and MCLK is active, the internal clock generator is still drawing minimal currents.

8.4. Micro Power Mode

Standby power consumption of the modulators can be minimized by placing them into a micro power mode, PWDN=1 and MCLK=0. Micro power mode requires setting the PWDN pin and halting MCLK to remove the clock generator input current. Micro power mode consumes only 10 μ W of power.

9. POWER SUPPLY

The CS5371/CS5372 modulators have one positive analog power supply pin, VA+, one negative analog power supply pin, VA-, one digital power supply pin, VD, and one digital ground pin, DGND.

The analog and digital circuitry is separated internally to enhance performance, therefore power must be supplied to all three supply pins and the digital ground pin must be referenced to system ground.

9.1. Power Supply Configurations

The CS5371/CS5372 analog supplies can be powered by a single +5 V supply and analog ground, or by dual supplies of ± 2.5 V or ± 3.0 V. When using dual supplies, the positive and negative analog power supplies must be equivalent in voltage but opposite in polarity and must satisfy the following conditions:

$$(VA+) - (VA-) < 6.6 \text{ volts}$$

$$(VD) - (VA-) < 7.6 \text{ volts}$$

These conditions permit several power supply configurations.

- VA+ = +5 V; VA- = 0 V; VD+ = +3 V to +5 V
- VA+ = +2.5 V; VA- = -2.5 V; VD+ = +3 V to +5 V
- VA+ = +3 V; VA- = -3 V; VD+ = +3 V

When used with the CS5376 digital filter the maximum voltage differential between the modulator digital supply, VD, and the CS5376 digital supply, VDD2, must be less than 0.3 V.

9.2. Power Supply Bypassing

The analog and digital supply pins, VA+, VA-, and VD, should be decoupled to system ground with 0.01 μ F and 10 μ F capacitors, or with a single 0.1 μ F capacitor. Bypass capacitors can be X7R, tantalum, or any other dielectric types.

9.3. SCR Latch-up Considerations

The VA- pin is tied to the CS5371/CS5372 substrate and should always be connected to the most negative supply voltage to ensure SCR latch-up does not occur. In general, latch-up may occur when any pin voltage is 0.7 V or more below VA-.

When using dual power supplies, it is recommended to connect the VA- analog supply pin to system ground using a reversed biased Schottky diode. This configuration clamps the VA- pin a maximum of 0.3 V above ground to ensure SCR latch-up does not occur during power up. If the VA+ supply ramps before the VA- supply, the VA- pin can be pulled above ground through the CS5371/CS5372. If the VA- supply pin is unintentionally pulled 0.7 V above the DGND pin, SCR latch-up can occur.

9.4. DC-DC Converter Considerations

Many measurement systems are battery powered and utilize DC-DC converters to generate the necessary supply voltages for the system. To minimize the effects of interference, it is desirable to

operate the DC-DC converter at a frequency which is rejected by the digital filter, or else synchronously to the modulator sample clock rate. A synchronous DC-DC converter whose operating frequency is derived from MCLK minimizes the potential for ‘beat frequencies’ appearing in the measurement band.

9.5. Power Supply Rejection

Power supply rejection of the CS5371/CS5372 modulators is frequency dependent. The CS5376 digital filter rejects power supply noise for frequencies above the filter corner frequency. For frequencies between DC and the digital filter corner frequency, power supply rejection is nearly constant at 90 dB.

10. PIN DESCRIPTION - CS5371

Rough Non-Inverting Input	INR+	1 •	24	PWDN	Power-down Enable
Fine Non-Inverting Input	INF+	2	23	LPWR	Low Power Mode Select
Fine Inverting Input	INF-	3	22	MFLAG	Modulator Flag Output
Rough Inverting Input	INR-	4	21	MDATA	Modulator Data Output
Positive Voltage Reference Input	VREF+	5	20	MSYNC	Modulator Sync Input
Negative Voltage Reference Input	VREF-	6	19	MCLK	Modulator Clock Input
Negative Analog Power Supply	VA-	7	18	VD	Positive Digital Power Supply
Positive Analog Power Supply	VA+	8	17	DGND	Digital Ground
No Internal Connection	NC	9	16	NC	No Internal Connection
No Internal Connection	NC	10	15	NC	No Internal Connection
No Internal Connection	NC	11	14	OFST	Offset Mode Select
No Internal Connection	NC	12	13	VD	Positive Digital Power Supply

Power Supplies
VA+ – Positive Analog Power Supply, pin 8

Positive supply voltage.

VA- – Negative Analog Power Supply, pin 7

Negative supply voltage.

VD – Positive Digital Power Supply, pin 13, 18

Positive supply voltage.

DGND – Digital Ground, pin 17
Analog Inputs
INR+ – Rough Non-Inverting Input, pin 1

Rough non-inverting analog input. The rough input settles non-linear currents to improve linearity on the fine input and reduce harmonic distortion.

INR- – Rough Inverting Input, pin 4

Rough inverting analog input. The rough input settles non-linear currents to improve linearity on the fine input and reduce harmonic distortion.

INF+ – Fine Non-Inverting Input, pin 2

Fine non-inverting analog input.

INF- – Fine Inverting Input, pin 3

Fine inverting analog input.

VREF+ – Positive Voltage Reference Input, pin 5

Input for an external +2.5 V voltage reference relative to VREF-.

VREF- – Negative Voltage Reference Input, pin 6

This pin must be tied to VA-.

*Digital Inputs***MCLK – Modulator Clock Input, pin 19**

A CMOS compatible clock input for the modulator internal master clock, nominally 2.048 MHz with an amplitude equal to the VD digital power supply.

MSYNC – Modulator Sync Input, pin 20

A low to high transition resets the internal clock phasing of the modulator. This assures the sampling instant and modulator data output are synchronous to the external system.

OFST – Offset Mode Select, pin 14

When high, adds approximately +100mV of offset to the analog inputs to guarantee any zero input Δ - Σ idle tones are removed. When low, no offset is added.

LPWR – Low Power Mode Select, pin 23

When set high with MCLK operating at 1.024 MHz, modulator power dissipation is reduced to 15 mW per channel.

PWDN – Power-down Mode, pin 24

When high, the modulator is in power down mode and consumes 1mW. Halting MCLK while in power down mode reduces modulator power dissipation to 10 μ W.

*Digital Outputs***MDATA – Modulator Data Output, pin 21**

Modulator data is output as a 1-bit serial data stream at a 512 kHz rate with an MCLK input of 2.048 MHz. Modulator data is output at a 256 kHz rate with an MCLK input of 1.024 MHz.

MFLAG – Modulator Flag Output, pin 22

A high level output indicates the modulator is unstable due to an over-range on the analog inputs.

11. PIN DESCRIPTION - CS5372

Ch. 1 Rough Non-Inverting Input	INR1+	1 •	24	PWDN1	Ch. 1 Power-down Enable
Ch. 1 Fine Non-Inverting Input	INF1+	2	23	LPWR	Low Power Mode Select
Ch. 1 Fine Inverting Input	INF1-	3	22	MFLAG1	Ch. 1 Modulator Flag Output
Ch. 1 Rough Inverting Input	INR1-	4	21	MDATA1	Ch. 1 Modulator Data Output
Positive Voltage Reference Input	VREF+	5	20	MSYNC	Modulator Sync Input
Negative Voltage Reference Input	VREF-	6	19	MCLK	Modulator Clock Input
Negative Analog Power Supply	VA-	7	18	VD	Positive Digital Power Supply
Positive Analog Power Supply	VA+	8	17	DGND	Digital Ground
Ch. 2 Rough Inverting Input	INR2-	9	16	MDATA2	Ch. 2 Modulator Data Output
Ch. 2 Fine Inverting Input	INF2-	10	15	MFLAG2	Ch. 2 Modulator Flag Output
Ch. 2 Fine Non-Inverting Input	INF2+	11	14	OFST	Offset Mode Select
Ch. 2 Rough Non-Inverting Input	INR2+	12	13	PWDN2	Ch. 2 Power-down Enable

Power Supplies
VA+ – Positive Analog Power Supply, pin 8

Positive supply voltage.

VA- – Negative Analog Power Supply, pin 7

Negative supply voltage.

VD – Positive Digital Power Supply, pin 18

Positive supply voltage.

DGND – Digital Ground, pin 17
Analog Inputs
INR1+, INR2+ – Channel 1 & 2 Rough Non-Inverting Inputs, pin 1, 12

Rough non-inverting analog inputs. The rough inputs settle non-linear currents to improve linearity on the fine inputs and reduce harmonic distortion.

INR1-, INR2- – Channel 1 & 2 Rough Inverting Inputs, pin 4, 9

Rough inverting analog inputs. The rough inputs settle non-linear currents to improve linearity on the fine inputs and reduce harmonic distortion.

INF1+, INF2+ – Channel 1 & 2 Fine Non-Inverting Input, pin 2, 11

Fine non-inverting analog inputs.

INF1-, INF2- – Channel 1 & 2 Fine Inverting Input, pin 3, 10

Fine inverting analog inputs.

VREF+ – Positive Voltage Reference Input, pin 5

Input for an external +2.5V voltage reference relative to VREF-.

VREF- – Negative Voltage Reference Input, pin 6

This pin must be tied to VA-.

*Digital Inputs***MCLK – Modulator Clock Input, pin 19**

A CMOS compatible clock input for the modulator internal master clock, nominally 2.048 MHz with an amplitude equal to the VD digital power supply.

MSYNC – Modulator Sync Input, pin 20

A low to high transition resets the internal clock phasing of the modulator. This assures the sampling instant and modulator data output are synchronous to the external system.

OFST – Offset Mode Select, pin 14

When high, adds approximately +100mV of offset to the analog inputs to guarantee any zero input Δ - Σ idle tones are removed. When low, no offset is added.

LPWR – Low Power Mode Select, pin 23

When set high with MCLK operating at 1.024 MHz, modulator power dissipation is reduced to 15 mW per channel.

PWDN1, PWDN2 – Channel 1 & 2 Power-down Mode, pin 24, 13

When high, the modulator is in power down mode and consumes 1mW. Halting MCLK while in power down mode reduces modulator power dissipation to 10 μ W.

*Digital Outputs***MDATA1, MDATA2 – Modulator Data Output, pin 21, 16**

Modulator data is output as a 1-bit serial data stream at a 512 kHz rate with an MCLK input of 2.048 MHz. Modulator data is output at a 256 kHz rate with an MCLK input of 1.024 MHz.

MFLAG1, MFLAG2 – Modulator Flag, pin 22, 15

A high level output indicates the modulator is unstable due to an over-range on the analog inputs.

12. PACKAGE DIMENSIONS

24 PIN SSOP PACKAGE DRAWING

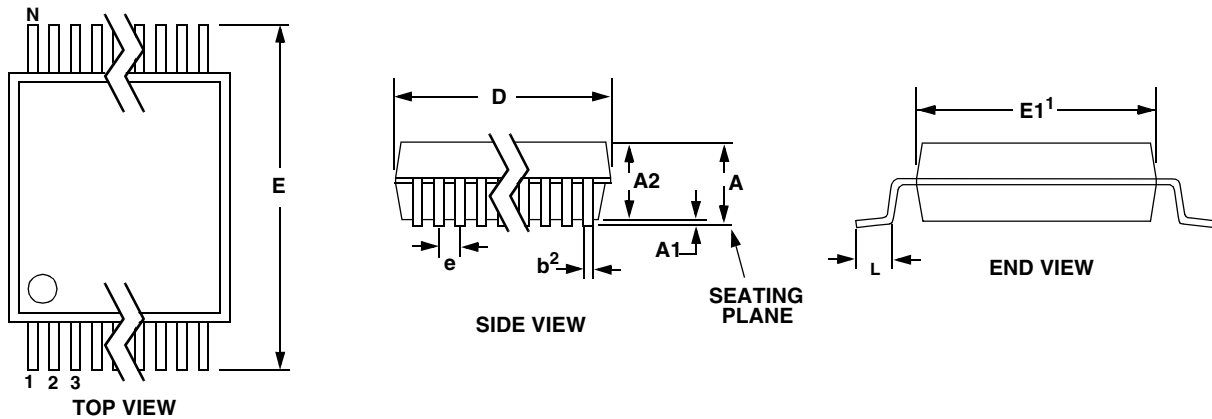

DIM	INCHES		MILLIMETERS		NOTE
	MIN	MAX	MIN	MAX	
A	--	0.084	--	2.13	
A1	0.002	0.010	0.05	0.25	
A2	0.064	0.074	1.62	1.88	
b	0.009	0.015	0.22	0.38	2,3
D	0.311	0.335	7.90	8.50	1
E	0.291	0.323	7.40	8.20	
E1	0.197	0.220	5.00	5.60	1
e	0.024	0.027	0.61	0.69	
L	0.025	0.040	0.63	1.03	
∞	0°	8°	0°	8°	

- Notes:
1. "D" and "E1" are reference datums and do not include mold flash or protrusions, but do include mold mismatch and are measured at the parting line, mold flash or protrusions shall not exceed 0.20 mm per side.
 2. Dimension "b" does not include dambar protrusion/intrusion. Allowable dambar protrusion shall be 0.13 mm total in excess of "b" dimension at maximum material condition. Dambar intrusion shall not reduce dimension "b" by more than 0.07 mm at least material condition.
 3. These dimensions apply to the flat section of the lead between 0.10 and 0.25 mm from lead tips.

SMART
Analog™