

Introducing Maverick EP9312

Jeff Klaas - Director of Engineering



Digital Audio Jukebox



Optional



Create a cost-effective solution for a digital audio jukebox meeting the following goals:

- Quick time-to-market
- 10x Real-time MP3 encoding
- Hardware based content security
- High-quality audio
- Home network enabled
- Robust I/O for OEM flexibility
- Low cost storage options
- Flexible user interface

Create a cost-effective solution for a digital audio jukebox meeting the following goals:

- ➔ Quick time-to-market
- ➔ 10x Real-time MP3 encoding
- ➔ Hardware based content security
- ➔ Low cost storage options
- ➔ Home network enabled
- ➔ High-quality audio
- ➔ Robust I/O for OEM flexibility
- ➔ Flexible user interface
- ✓ ARM 920T Core
- ✓ MaverickCrunch™ Engine
- ✓ MaverickLock™ Security
- ✓ EIDE Controller
- ✓ Ethernet MAC
- ✓ I²S 24-bit audio Interface
- ✓ USB, UARTs, IrDA
- ✓ LCD Controller
- ✓ Touchscreen Controller
- ✓ Keypad Interface

The right feature set and performance level at the right price-point!

ARM920T Processor

- ✓ 200 MHz Processor Clock
- ✓ 16KB instruction & data caches
- ✓ 64 entry instruction & data TLB
- ✓ Independent lockable pages
- ✓ Windows CE compatible MMU

Flexible interrupts & GPIO

- ✓ Up to 64 interrupts
- ✓ 32 priority levels
- ✓ 16 expanded GPIO signals

Clocks & Timers

- ✓ Dual PLL produces all clocks
- ✓ 6 timers & clocks + RTC

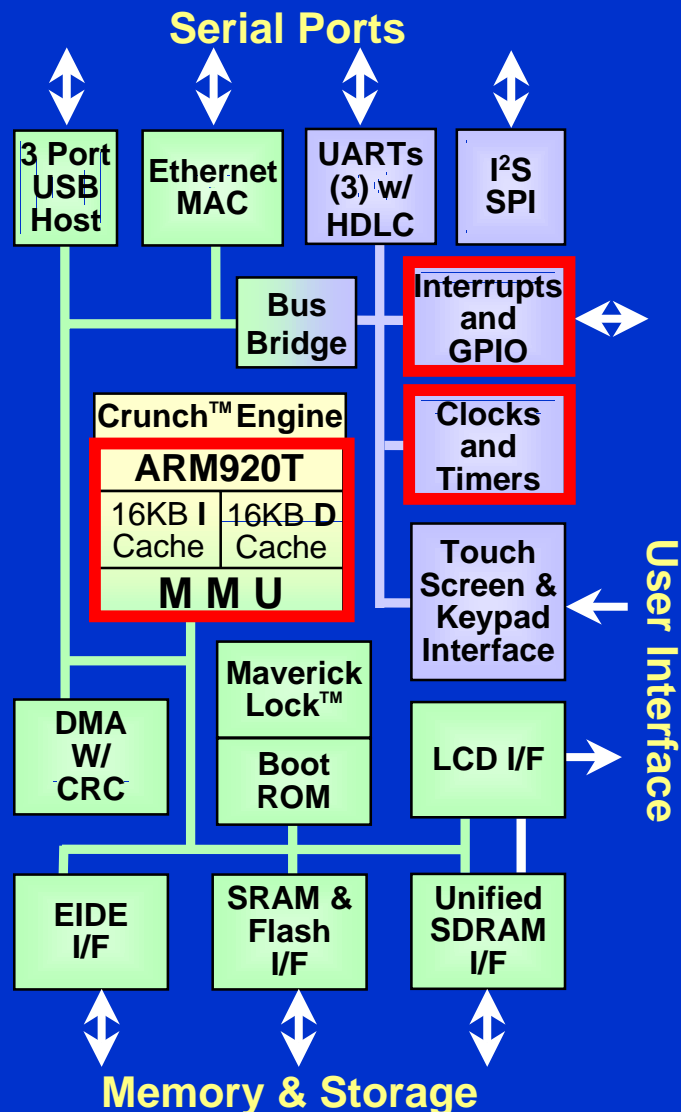

General Architecture for Market Specific Extensions

- ✓ Balanced approach to algorithm efficiency
- ✓ Floating point, integer and signal processing instruction set
- ✓ Hardware Interlocks to remove implementation details
- ✓ Full tools support from Cygnus

It ain't PICCOLO!

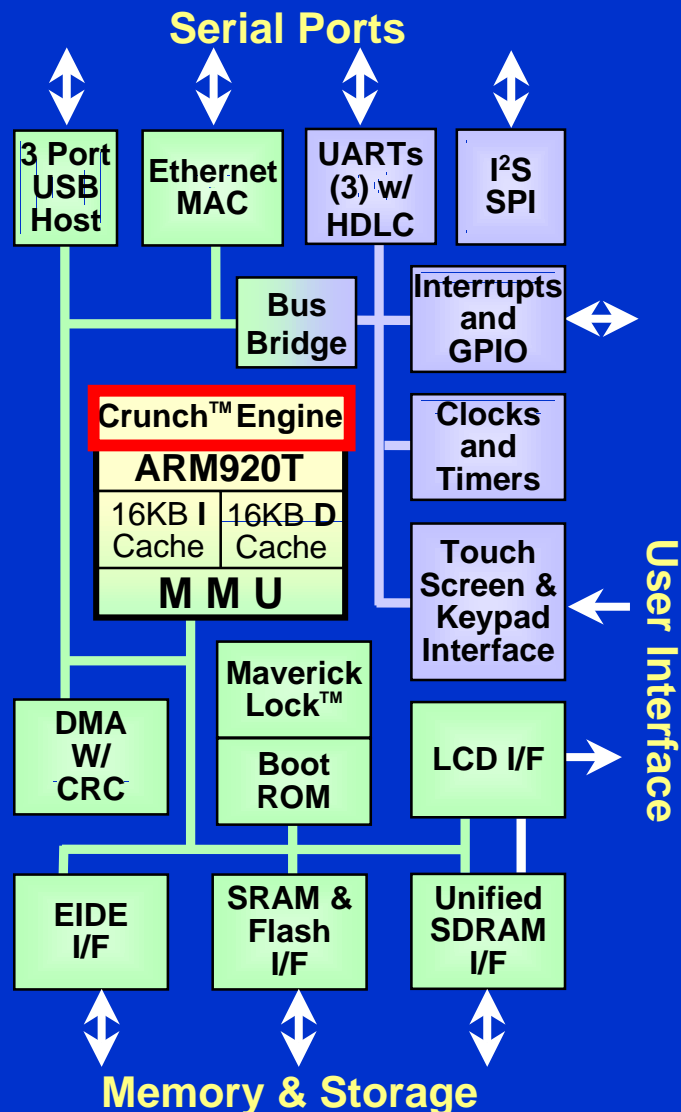

Hardware Support

- ✓ IEEE Single/Double Floating Point
- ✓ 32/64 Bit Integer
- ✓ Add/Multiply/Compare
- ✓ Integer MAC 32-bit input with 72 bit accumulate
- ✓ Integer Shifts
- ✓ Float ↔ Integer Conversion

Implementation

- ✓ Register file is 0 stall at CPU speed
- ✓ < 2mm² in 0.25u
- ✓ Hardware forwarding and interlock

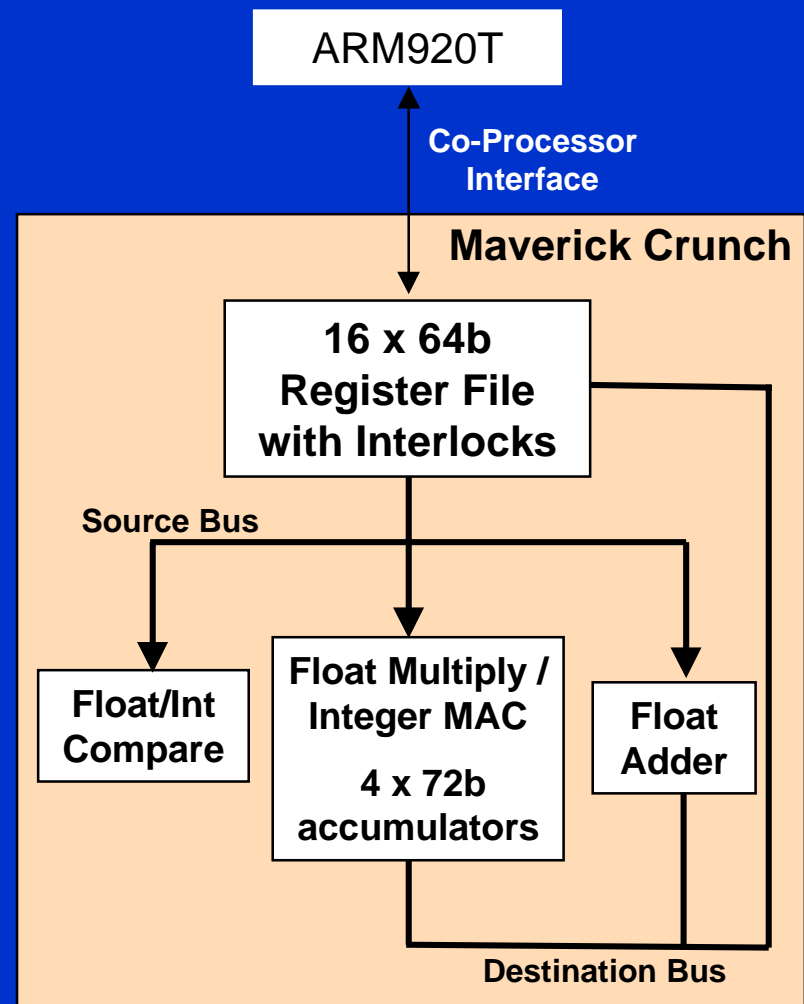

Single Code Stack for Control and Computation

- ✓ ARM handles loop and addressing
- ✓ Maverick Crunch handles compute
- ✓ Integer MAC (32bit X 32bit + 72bit --> 72bit) for high MIP filters
- ✓ IEEE-754 floating point provides dynamic range
- ✓ 16x64b register file plus 4x72b accumulators

High Precision FIR Followed by Scale

- ✓ $17 * (N/4) + 26$ with Maverick Crunch
- ✓ >6X improvement over ARM9 CPU

```

;Floating point example
;R2 points to start of filter data block
;R3 points to start of filter coefficient block
;R4 points to scale factors
;R5 points to stored value

;Loop setup
;N/4 Loop Software unrolled for minimum stalls
loop:
SUBS    R0, R0, #1                ;decrement loop count
CMP     R0, #0                    ;Test loop counter
CFLDR32 MVFX0, [R2], #4           ;Load Coprocessor regs w/data
CFLDR32 MVFX1, [R3], #4           ;Load Coprocessor regs w/data
CFLDR32 MVFX2, [R2], #4           ;Load Coprocessor regs w/data
CFLDR32 MVFX3, [R3], #4           ;Load Coprocessor regs w/data
CFLDR32 MVFX4, [R2], #4           ;Load Coprocessor regs w/data
CFMADDA32 MVAX0, MVAX0, MVFX0, MVFX1 ;FX0*FX1+AX0->AX0
CFLDR32 MVFX0, [R3], #4           ;Load Coprocessor regs w/data
CFMADDA32 MVAX0, MVAX0, MVFX2, MVFX3 ;FX2*FX3+AX0->AX0
CFLDR32 MVFX1, [R2], #4           ;Load Coprocessor regs w/data
CFLDR32 MVFX2, [R3], #4           ;Load Coprocessor regs w/data
CFMADDA32 MVAX0, MVAX0, MVFX4, MVFX0 ;FX4*FX0+AX0->AX0
CFMADDA32 MVAX0, MVAX0, MVFX1, MVFX2 ;FX1*FX2+AX0->AX0
BNE     loop                       ;Exit if equal

;Finish calculations
NOP                                           ;Any Non-coprocessor Inst
NOP                                           ;Any Non-coprocessor Inst
CFMV64A  MVDX10, MVAX0                 ;Convert i72A->i64, sat & rnd
CFLDRS  MVF13, [R4]                     ;Load coprocessor scale factor
CFCVT64S MVF11, MVDX10                  ;Convert i64->f32
CFMULS  MVF14, MVF11, MVF13            ;Multiply two f32's
CFSTRS  MVF14, [R5]                     ;final result stored to mem
    
```

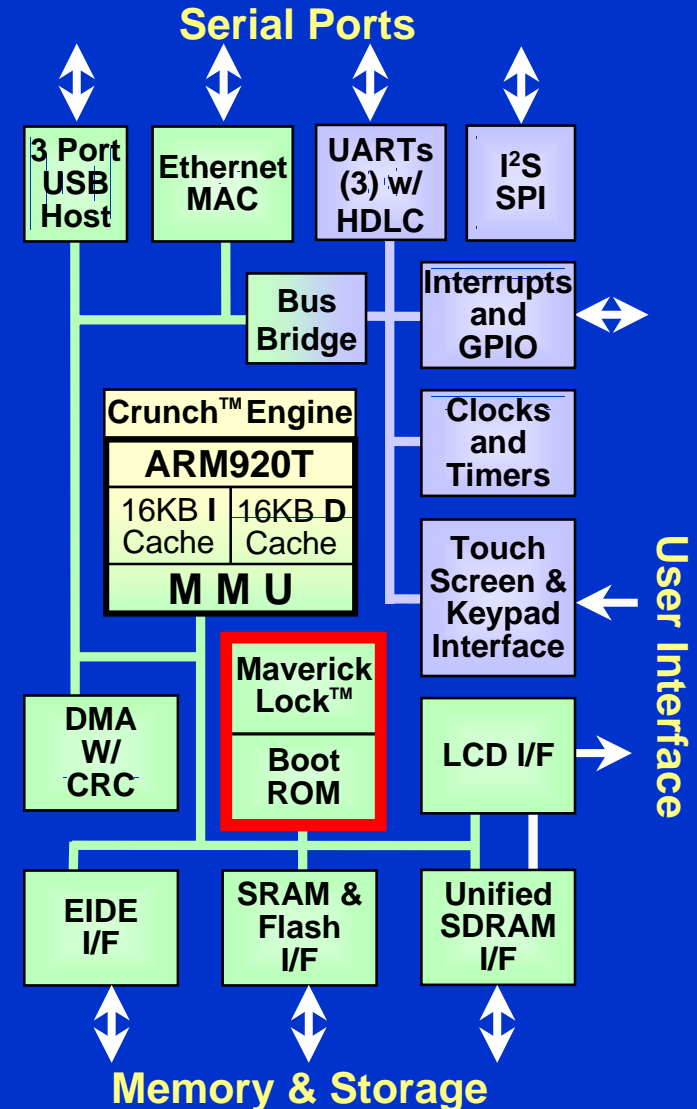

Secrets stay Secret

- ✓ Unique emulation technology allows CPU to create locked Cache/MMU entries without internal or external memory
- ✓ 256 bits of laser fuses provide on chip permanent IDs and passwords
- ✓ Security boot firmware and private passwords are “invisible” except when IC is “Locked”
- ✓ Debug and manufacturing test modes disabled when IC is “Locked”
- ✓ Encrypted Firmware

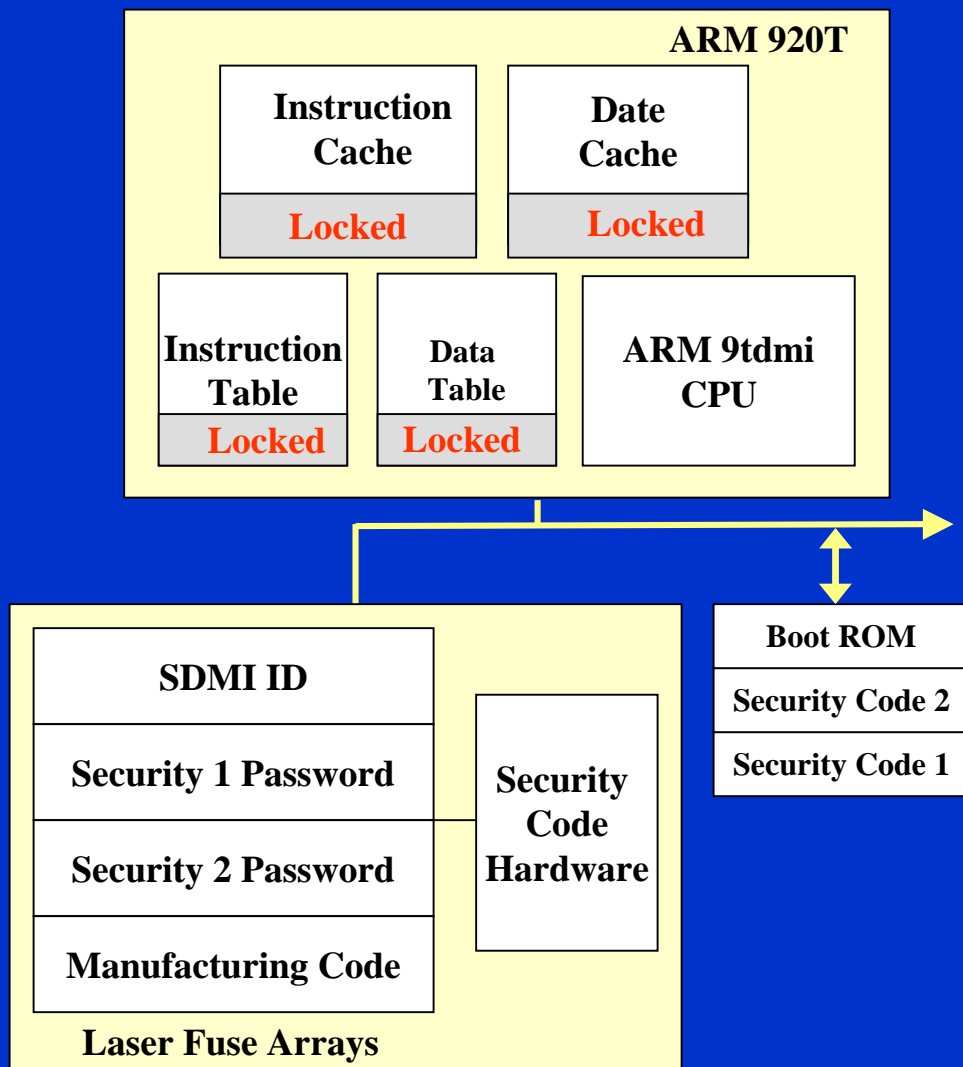

Single IC provides secure hardware environment

- ✓ General architecture that can be used by partner security vendors
- ✓ Combination of boot ROM, laser fuses and gate level IP
- ✓ Multiple security vendors can co-exist in same system



Wide choice of input sources

- ✓ 3.6864 MHz
- ✓ 4.0 MHz
- ✓ 12.288 MHz
- ✓ Many other viable options

Multiple clock requirements

- ✓ Independent processor & video clocks
- ✓ 48 MHz - USB and IrDA
- ✓ 18.432 MHz - IrDA
- ✓ 25 MHz - Ethernet
- ✓ 3.6864 MHz- UARTs
- ✓ 48 KHz Audio (3.072 MHz * 2, 3, or 4)

Implementation

- ✓ Dual cascadable PLLs
- ✓ Glitch-free enable/disable
- ✓ Programmable frequency control
- ✓ Programmable phase control

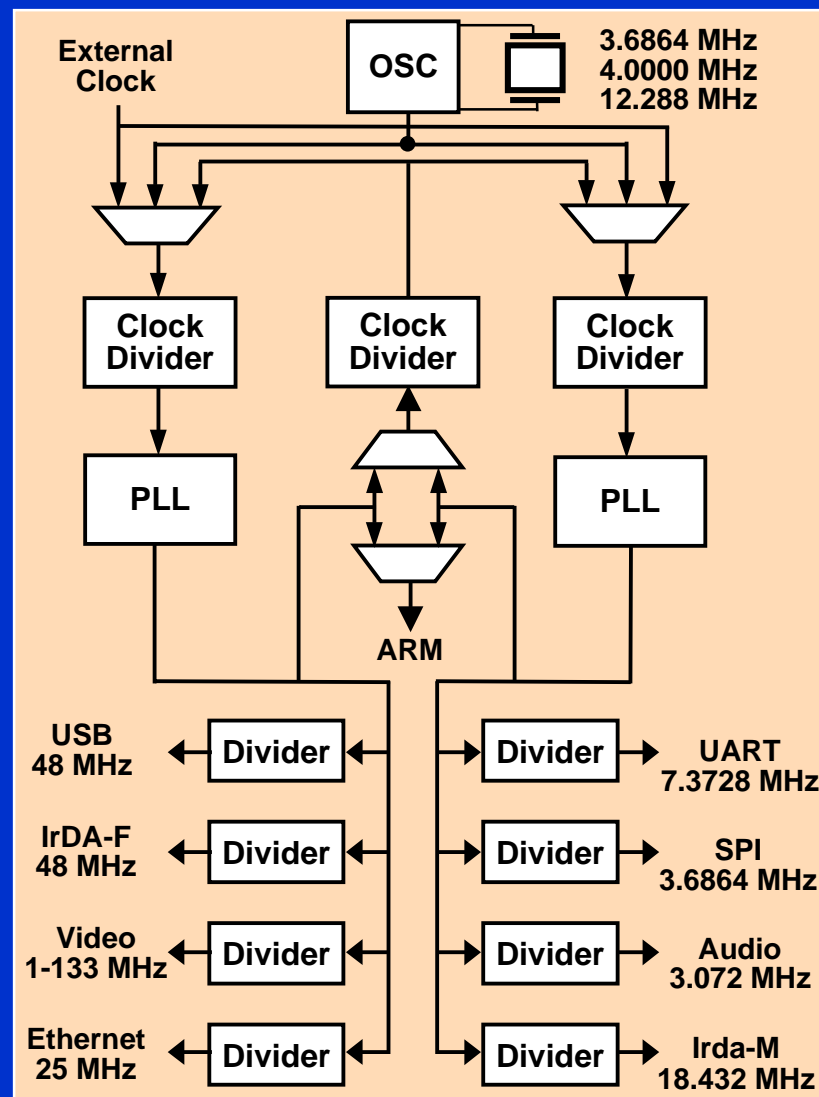

SDRAM interface (unified memory)

- ✓ 1-4 banks of 66 or 100 MHz SDRAM
- ✓ 16 or 32-bit data path
- ✓ Separate display refresh port

EIDE interface

- ✓ Up to UDMA-33 performance
- ✓ Supports two devices (CD & hard drive)

General purpose memory interface

- ✓ ROM
- ✓ SRAM
- ✓ Flash Memory
- ✓ 8 chip selects

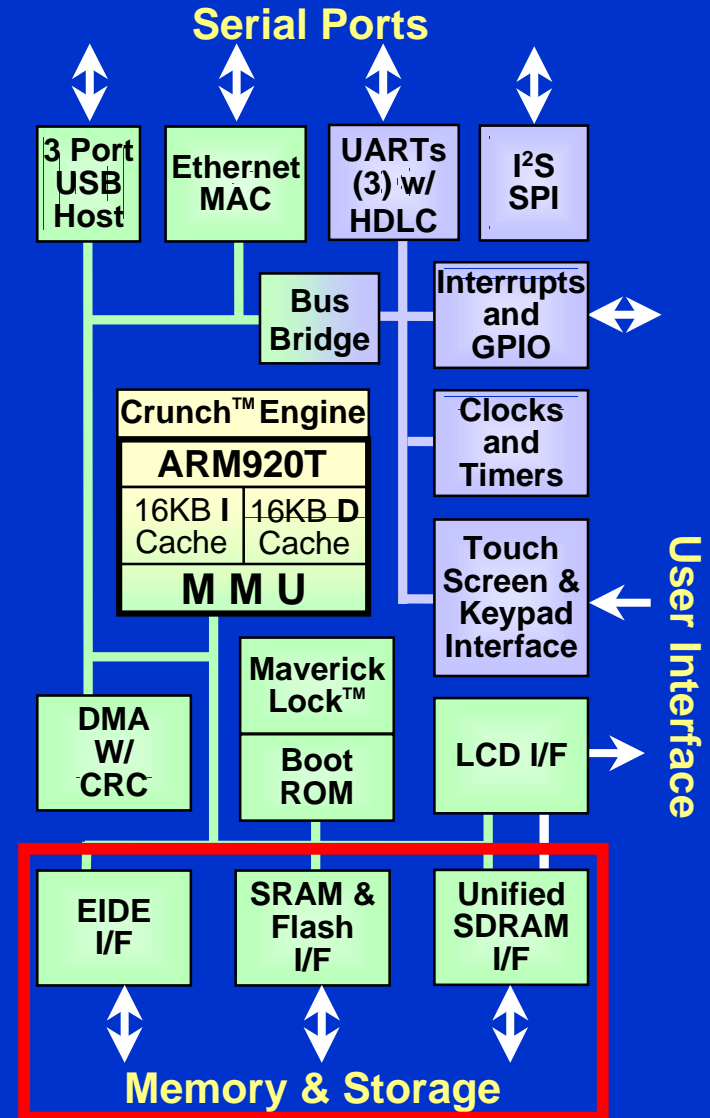

Ethernet Media Access Controller

- ✓ Media independent interface to external PHY
- ✓ 1, 10, 100 Mbps operation
- ✓ HPNA 1.0 compatible

3 port USB host

- ✓ Integrated USB PHYs
- ✓ USB 1.0 protocol

Audio & telephony

- ✓ Interfaces directly to I²S codec
- ✓ Interfaces directly to serial soft modem
- ✓ Alternate configuration as SPI

Three 16550 compatible UARTs

- ✓ UART with HDLC
- ✓ UART with modem & HDLC
- ✓ UART with slow, medium, and fast IrDA

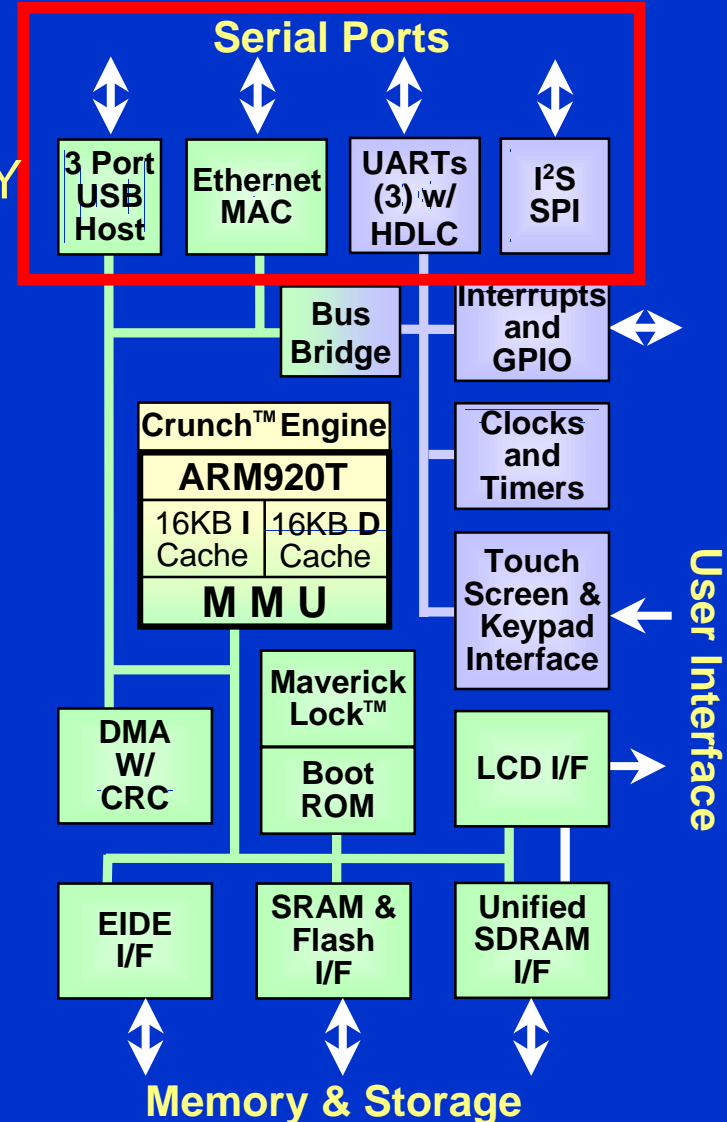

LCD interface

- ✓ 4, 8, 16, 18 bits per pixel
- ✓ Dedicated SDRAM memory port
- ✓ Pulse width modulated brightness control
- ✓ 6-bit DAC for LCD contrast control

Touchscreen interface

- ✓ 4, 5, or 8-wire resistive screen
- ✓ Touchscreen interrupt provided
- ✓ Onboard ADC input

8 x 8 keyboard scan

- ✓ Interrupt generated on each new key stroke
- ✓ Keyscan register cleared each time it is read
- ✓ Hardware debouncing

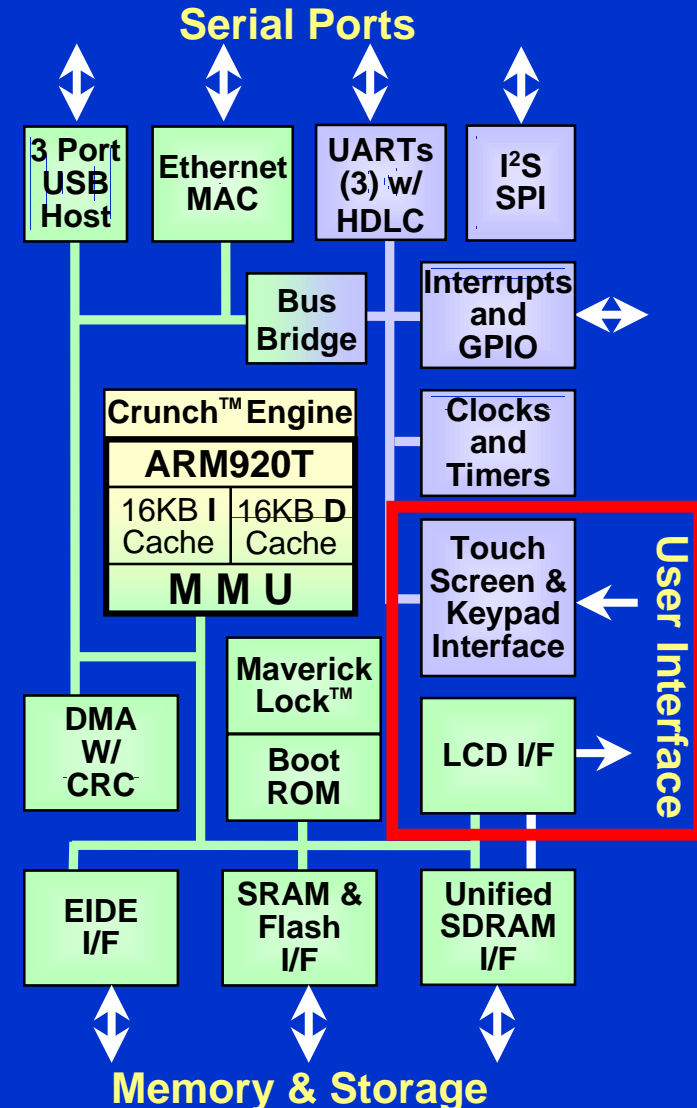

- **Transistor count ~ 5.7 million**
- **Process - 0.25u, single poly, 4 metal (6SF)**
- **Supply voltages - 2.5V core, 3.3V pads**
- **Processor speed - 200 MHz**
- **Bus speed - 100 MHz**
- **Package - 20x20 PBGA, 352 pin**
- **Pads - 332 on 65u pitch**
- **Power dissipation - <1.5W**

