



OpenSPARC™ T2 Processor Design and Verification User's Guide

Sun Microsystems, Inc.
www.sun.com

Part No. 820-2729-10
May 2008, Revision B

Submit comments about this document at: <http://www.sun.com/hwdocs/feedback>

Copyright 2007 Sun Microsystems, Inc., 4150 Network Circle, Santa Clara, California 95054, U.S.A. All rights reserved.

Sun Microsystems, Inc. has intellectual property rights relating to technology that is described in this document. In particular, and without limitation, these intellectual property rights may include one or more of the U.S. patents listed at <http://www.sun.com/patents> and one or more additional patents or pending patent applications in the U.S. and in other countries.

This document and the product to which it pertains are distributed under licenses restricting their use, copying, distribution, and decompilation. No part of the product or of this document may be reproduced in any form by any means without prior written authorization of Sun and its licensors, if any.

Third-party software, including font technology, is copyrighted and licensed from Sun suppliers.

Parts of the product may be derived from Berkeley BSD systems, licensed from the University of California. UNIX is a registered trademark in the U.S. and in other countries, exclusively licensed through X/Open Company, Ltd.

Sun, Sun Microsystems, the Sun logo, Java, AnswerBook2, docs.sun.com, and Solaris are trademarks or registered trademarks of Sun Microsystems, Inc. in the U.S. and in other countries.

All SPARC trademarks are used under license and are trademarks or registered trademarks of SPARC International, Inc. in the U.S. and in other countries. Products bearing SPARC trademarks are based upon an architecture developed by Sun Microsystems, Inc.

The OPEN LOOK and Sun™ Graphical User Interface was developed by Sun Microsystems, Inc. for its users and licensees. Sun acknowledges the pioneering efforts of Xerox in researching and developing the concept of visual or graphical user interfaces for the computer industry. Sun holds a non-exclusive license from Xerox to the Xerox Graphical User Interface, which license also covers Sun's licensees who implement OPEN LOOK GUIs and otherwise comply with Sun's written license agreements.

U.S. Government Rights—Commercial use. Government users are subject to the Sun Microsystems, Inc. standard license agreement and applicable provisions of the FAR and its supplements.

DOCUMENTATION AND REGISTER TRANSFER LEVEL (RTL) ARE PROVIDED "AS IS" AND ALL EXPRESS OR IMPLIED CONDITIONS, REPRESENTATIONS AND WARRANTIES, INCLUDING ANY IMPLIED WARRANTY OF MERCHANTABILITY, FITNESS FOR A PARTICULAR PURPOSE OR NON-INFRINGEMENT, ARE DISCLAIMED, EXCEPT TO THE EXTENT THAT SUCH DISCLAIMERS ARE HELD TO BE LEGALLY INVALID.

Copyright 2007 Sun Microsystems, Inc., 4150 Network Circle, Santa Clara, Californie 95054, États-Unis. Tous droits réservés.

Sun Microsystems, Inc. possède les droits de propriété intellectuelle relatifs à la technologie décrite dans ce document. En particulier, et sans limitation, ces droits de propriété intellectuelle peuvent inclure un ou plusieurs brevets américains listés sur le site <http://www.sun.com/patents>, un ou les plusieurs brevets supplémentaires ainsi que les demandes de brevet en attente aux les États-Unis et dans d'autres pays.

Ce document et le produit auquel il se rapporte sont protégés par un copyright et distribués sous licences, celles-ci en restreignent l'utilisation, la copie, la distribution, et la décompilation. Aucune partie de ce produit ou document ne peut être reproduite sous aucune forme, par quelque moyen que ce soit, sans l'autorisation préalable et écrite de Sun et de ses bailleurs de licence, s'il y en a.

Tout logiciel tiers, sa technologie relative aux polices de caractères, comprise, est protégé par un copyright et licencié par des fournisseurs de Sun.

Des parties de ce produit peuvent dériver des systèmes Berkeley BSD licenciés par l'Université de Californie. UNIX est une marque déposée aux États-Unis et dans d'autres pays, licenciée exclusivement par X/Open Company, Ltd.

Sun, Sun Microsystems, le logo Sun, Java, AnswerBook2, docs.sun.com, et Solaris sont des marques de fabrique ou des marques déposées de Sun Microsystems, Inc. aux États-Unis et dans d'autres pays.

Toutes les marques SPARC sont utilisées sous licence et sont des marques de fabrique ou des marques déposées de SPARC International, Inc. aux États-Unis et dans d'autres pays. Les produits portant les marques SPARC sont basés sur une architecture développée par Sun Microsystems, Inc.

L'interface utilisateur graphique OPEN LOOK et Sun™ a été développée par Sun Microsystems, Inc. pour ses utilisateurs et licenciés. Sun reconnaît les efforts de pionniers de Xerox dans la recherche et le développement du concept des interfaces utilisateur visuelles ou graphiques pour l'industrie informatique. Sun détient une licence non exclusive de Xerox sur l'interface utilisateur graphique Xerox, cette licence couvrant également les licenciés de Sun implémentant les interfaces utilisateur graphiques OPEN LOOK et se conforment en outre aux licences écrites de Sun.

LA DOCUMENTATION EST FOURNIE "EN L'ÉTAT" ET TOUTES AUTRES CONDITIONS, DÉCLARATIONS ET GARANTIES EXPRESSES OU TACITES SONT FORMELLEMENT EXCLUES DANS LA LIMITE DE LA LOI APPLICABLE, Y COMPRIS NOTAMMENT TOUTE GARANTIE IMPLICITE RELATIVE À LA QUALITÉ MARCHANDE, À L'APTITUDE À UNE UTILISATION PARTICULIÈRE OU À L'ABSENCE DE CONTREFAÇON.



Contents

Preface ix

1. Quick Start 1-1

- 1.1 System Requirements 1-1
- 1.2 Running Simulations and Synthesis 1-3

2. OpenSPARC T2 Design Implementation 2-1

- 2.1 OpenSPARC T2 Design 2-1
- 2.2 OpenSPARC T2 Components 2-3
 - 2.2.1 SPARC Physical Core 2-4
 - 2.2.2 SPARC System-On Chip (SoC) 2-4
- 2.3 Module Directory Structure 2-5
- 2.4 Megacells 2-6

3. OpenSPARC T2 Verification Environment 3-1

- 3.1 OpenSPARC T2 Verification Environment 3-1
- 3.2 Running a Regression 3-3
 - 3.2.1 What the `sims` Command Does 3-4
- 3.3 PLI Code Used For the Test Bench 3-5
- 3.4 Verification Test File Locations 3-5

4. OpenSPARC T2 Synthesis 4-1

4.1 Synthesis Flow for the OpenSPARC T2 Processor 4-1

4.2 Synthesis Output 4-3

A. Design and Verification Manual Pages A-1

A.1 sims A-1

A.2 midas help A-22

A.3 regreport A-31

Figures

FIGURE 2-1 OpenSPARC T2 Chip Block Diagram 2–3

Tables

TABLE 1-1	Disk Space Requirements	1-1
TABLE 1-2	Contents of the OpenSPARCT2 Directory	1-3
TABLE 1-3	Environment Variables in <code>.cshrc</code> File	1-4
TABLE 2-1	OpenSPARC T2 Top-Level Clusters	2-5
TABLE 3-1	Source Code Types in the Verification Environment	3-2
TABLE 3-2	Details of Regression Groups	3-3
TABLE 3-3	PLI Source Code and Object Libraries	3-5
TABLE 3-4	Verification Test File Directories	3-6
TABLE 4-1	Synthesis Script Details	4-2
TABLE 4-2	Synthesis Output	4-3
TABLE A-1	Environment Variables	A-19

Preface

The *OpenSPARC™ T2 Processor Design and Verification User's Guide* gives an overview of the design hierarchy on the OpenSPARC T2 processor. It also describes the files, procedures, and tools needed for running simulations and synthesis on the OpenSPARC T2 processor.

This book covers the following topics:

- Design and Verification implementation overview
- Design and Verification directory and files structure
- System and Electronic Design Automation (EDA) tools required to run simulations and synthesis
- Tools and scripts required to run simulation or complete regressions, including simulation flow
- Synthesis flow and scripts

How This Document Is Organized

[Chapter 1](#) describes quick steps to run simulations after you download the design and verification files from the web site. It also includes system requirements and EDA tools requirements to run simulations and synthesis.

[Chapter 2](#) gives an overview of the OpenSPARC T2 design hierarchy and directory structure.

[Chapter 3](#) gives an overview of the OpenSPARC T2 verification environment implementation and directory structure. The verification environment includes test benches, tests, scripts, and Verilog Programming Language Interface (PLI).

[Chapter 4](#) describes the synthesis flow and synthesis scripts.

Appendix A has manual pages for regression commands.

Using UNIX Commands

This document might not contain information about basic UNIX® commands and procedures such as shutting down the system, booting the system, and configuring devices. Refer to the following for this information:

- Software documentation that you received with your system
- Solaris™ Operating System documentation, which is at:

<http://docs.sun.com>

Shell Prompts

Shell	Prompt
C shell	<i>machine-name%</i>
C shell superuser	<i>machine-name#</i>
Bourne shell and Korn shell	\$
Bourne shell and Korn shell superuser	#

Typographic Conventions

Typeface*	Meaning	Examples
AaBbCc123	The names of commands, files, and directories; on-screen computer output	Edit your <code>.login</code> file. Use <code>ls -a</code> to list all files. % You have mail.
AaBbCc123	What you type, when contrasted with on-screen computer output	% su password:
<i>AaBbCc123</i>	Book titles, new words or terms, words to be emphasized. Replace command-line variables with real names or values.	Read Chapter 6 in the <i>User's Guide</i> . These are called <i>class</i> options. You <i>must</i> be superuser to do this. To delete a file, type <code>rm filename</code> .

* The settings on your browser might differ from these settings.

Related Documentation

The documents listed as online or download are available at:

<http://www.opensparc.net/>

Application	Title	Part Number	Format	Location
Documentation	<i>OpenSPARC T2 Core Microarchitecture Specification</i>	820-2545	PDF	Online
Documentation	<i>OpenSPARC T2 System-On-Chip (SoC) Microarchitecture Specification</i>	820-2620	PDF	Online
Documentation	<i>OpenSPARC T2 Processor Megacell Specification</i>	820-2728	PDF	Online
Documentation	<i>OpenSPARC T2 Processor Design and Verification User's Guide</i>	820-2729	PDF	Online

Documentation, Support, and Training

Sun Function	URL
Documentation	http://www.sun.com/documentation/
Support	http://www.sun.com/support/
Training	http://www.sun.com/training/

Third-Party Web Sites

Sun is not responsible for the availability of third-party web sites mentioned in this document. Sun does not endorse and is not responsible or liable for any content, advertising, products, or other materials that are available on or through such sites or resources. Sun will not be responsible or liable for any actual or alleged damage or loss caused by or in connection with the use of or reliance on any such content, goods, or services that are available on or through such sites or resources.

Sun Welcomes Your Comments

Sun is interested in improving its documentation and welcomes your comments and suggestions. You can submit your comments by going to:

<http://www.sun.com/hwdocs/feedback>

Please include the title and part number of your document with your feedback:

OpenSPARC T2 Processor Design and Verification User's Guide,
part number 820-2729-10

Quick Start

This chapter covers the following topics:

- [System Requirements](#)
- [EDA Tool Requirements](#)
- [Running Simulations and Synthesis](#)

Before you start running simulations or synthesis, make sure you meet system requirements and that you have the required Electronic Design Automation (EDA) tools. Once you download the OpenSPARC T2 tar file from the <http://www.opensparc.net> web site, follow the steps in this chapter to get started and run your first regression on the OpenSPARC T2 design.

1.1 System Requirements

OpenSPARC T2 regressions are currently supported to run on SPARC systems running the Solaris 9 or Solaris 10 Operating System and x86_64 systems running Linux operating system.

Disk space requirements are listed in [TABLE 1-1](#).

TABLE 1-1 Disk Space Requirements

Disk Space required	Required for:
3.1 Gbyte	Download, unzip or uncompress, and extract from the tar file
0.3 Gbyte	Run a mini-regression

TABLE 1-1 Disk Space Requirements

Disk Space required	Required for:
11.5 Gbyte	Run a full regression
1.1 Gbyte	Run synthesis
17 Gbyte	Total

EDA Tool Requirements

This section describes the commercial EDA tools required for running simulations for the OpenSPARC T2 processor and synthesizing OpenSPARC T2 Verilog Register Transfer Level (RTL) code.

EDA Simulation Tools

The following EDA tools are required to run Verilog simulations: Verilog Simulator, either VCS or NCVerilog.

- VCS from Synopsys, version vcsY-2006.06-7 or later OR
- NCVerilog from Cadence, version ncoverilog,v6.11 or later
- Vera from Synopsys, version vera,vX-2005.12-1 or later

The following EDA tools are optional for running Verilog simulations:

- Debussy from Novas, version 5.3v19 or later

EDA Synthesis Tools

The following EDA tool is required to perform Verilog RTL synthesis:

- Design Compiler from Synopsys, version X-2005.09 or later

1.2 Running Simulations and Synthesis

This section outlines the steps needed to obtain the simulation tools, set up the simulation environment, run the simulation, and read its log file.

▼ Get the Simulation Files

1. Download the file.

Download the `OpenSPARCT2.tar.bz2` file from the <http://www.opensparc.net> web site. For this procedure's examples, the destination directory is:

```
/home/johndoe/OpenSPARCT2
```

2. Change directories to the directory where you downloaded the file. For example:

```
% cd /home/johndoe/OpenSPARCT2
```

3. Use the `bunzip2` command to unzip the file.

```
% bunzip2 OpenSPARCT2.tar.bz2
```

4. Extract the tar file using the `tar` command.

```
% tar -xvf OpenSPARCT2.tar
```

This step creates the files and subdirectories listed in [TABLE 1-2](#) in your current directory.

TABLE 1-2 Contents of the OpenSPARCT2 Directory

Name	Type	Description
<code>OpenSPARCT2.cshrc</code>	File	File to set up environment variables and paths for the SPARC/Solaris platform
<code>OpenSPARCT2.cshrc.linux</code>	File	File to set up environment variables and paths for the x64/Linux platform
<code>README</code>	File	Instructions to set up and run simulations
<code>lib</code>	Directory	Verilog libraries
<code>verif</code>	Directory	Verification directories and files

TABLE 1-2 Contents of the OpenSPARCT2 Directory (*Continued*)

Name	Type	Description
design	Directory	Verilog RTL for OpenSPARC T2 design
tools	Directory	Tools and scripts needed to run simulations and synthesis
doc	Directory	Documentation in PDF form for the OpenSPARC T2 processor

▼ Set Up Environment Variables

Edit the `OpenSPARCT2.cshrc` file to set the required environment variables as shown in [TABLE 1-3](#):

TABLE 1-3 Environment Variables in `.cshrc` File

Environment Variable	Usage	Example value
DV_ROOT	Running simulations and synthesis	<code>/home/johndoe/OpenSPARCT2</code> (Directory where you ran the <code>tar</code> command above)
MODEL_DIR	Running simulations	<code>/home/johndoe/OpenSPARCT2_model</code> (Directory where you want to run your simulations)
VERA_HOME	Running simulations	<code>/import/EDAtools/vera/vera,v6.2.10/5.x</code> (Directory where Vera is installed)
NOVAS_HOME	Running simulations	<code>/import/EDAtools/debussy/debussy,v5.3v19/5.x</code> (Directory where Debussy is installed)
VCS_HOME	Running VCS simulations	<code>/import/EDAtools/vcs7.1.1R21</code> (Directory where VCS is installed)
NCV_HOME	Running NCV simulation	<code>/import/EDAtools/ncverilog/ncverilog,v6.11.s3/5.x</code> (Directory where NCV is installed)
SYN_HOME	Running synthesis	<code>/import/EDAtools/synopsys/synopsys.vX-2005.09</code> (Directory where Synopsys is installed)
CC_BIN	Compiling PLI code	<code>/import/freetools/local/gcc/3.3.2/bin</code> (Directory where C++ Compiler binaries are installed)
LM_LICENSE_FILE	Running simulations and synthesis	<code>/import/EDAtools/licenses/synopsys_key:/import/EDAtools/licenses/ncverilog_key</code> (EDA tool license files)

Note – For x64/Linux platform, edit `OpenSPARCT2.cshrc.linux` file to set required environment variables

Once you set the environment variables from [TABLE 1-3](#), the `OpenSPARCT2.cshrc` file sets the following environment variables:

- `TRE_ENTRY`
- `TRE_SEARCH`
- `PERL_MODULE_BASE`
- `PERL_PATH`

The `OpenSPARCT2.cshrc` script also adds the following directories to your `PATH` and `path` variables:

- `$DV_ROOT/tools/bin`
- `$VCS_HOME/bin`
- `$VERA_HOME/bin`
- `$SYN_HOME/sparcOS5/syn/bin`
- `$CC_BIN`

After completing your `OpenSPARCT2.cshrc` file edits, source it by using the `source` command:

```
% source /home/johndoe/OpenSPARCT2/OpenSPARCT2.cshrc
```

You might want to include the above command in your `~/ .cshrc` file so that the above environment variables are set every time you log in.

▼ Run Your First Regression

The OpenSPARC T2 Design/Verification package comes with four test bench environments: `cmp1`, `cmp8`, `fc1`, and `fc8`.

The `cmp1` environment consists of:

- One SPARC CPU core
- Cache
- Memory
- Crossbar

The `cmp1` environment does not have an I/O subsystem.

The `cmp8` environment consists of:

- Eight SPARC CPU cores
- Cache
- Memory

- Crossbar

The `cmp8` environment does not have an I/O subsystem.

The `fc1` environment consists of:

- A full OpenSPARC T2 chip with one SPARC Core
- Cache
- Memory
- Crossbar
- I/O subsystem

The `fc8` environment consists of:

- A full OpenSPARC T2 chip, including all eight cores
- Cache
- Memory
- Crossbar
- I/O subsystem

Each environment can perform either a mini-regression or a full regression.

To run a regression, use the `sims` command as described in [To Run a Regression](#).

The important parameters for the `sims` command are:

- `-sys`: system type

Set this to `cmp1` or `cmp8` or `fc1` or `fc8`. For example: **`-sys=cmp1`**

- `-group`: Regression group name

The choices for `-group` are: `cmp1_mini_T2`, `cmp1_all_T2`, `cmp8_mini_T2`, `cmp8_all_T2`, `fc1_mini_T2`, and `fc1_all_T2`, `fc8_mini_T2`, and `fc8_all_T2`. For example: `-group=cmp1_mini_T2`

- For help, type “`sims -h`”

▼ To Run a Regression

1. Create the `$MODEL_DIR` directory.

```
% mkdir $MODEL_DIR
```

2. Change directory to \$MODEL_DIR.

```
% cd $MODEL_DIR
```

This is where the simulations are run.

3. Run a mini-regression for the cmp1 environment using the VCS simulator.

```
% sims -sys=cmp1 -group=cmp1_mini_T2
```

This command creates two directories:

- A directory called `cmp1` under `$MODEL_DIR`. The regression compiles Vera and Verilog code under the `cmp1` directory. This is the Vera and Verilog “build” directory.
- A directory named with today’s date and a serial number, such as `2007_01_07_0` (the format is `YYYY_MM_DD_ID`) under the current directory where simulations will run. This is the Verilog simulation’s “run” directory. There is one subdirectory under this directory for each diagnostics test.

By default, the simulations are run with Vera.

4. Once simulations are completed, run the `regreport` command to generate a regression report.

```
% cd run-directory
% regreport $PWD > report.log
```

Where `run-directory` is the “run” directory created in the above step, such as `2007_08_07_0`.

The `cmp1_mini_T2` regression has 51 tests. An example of its `report.log` output is shown below:

Group	Total	PASS	FAIL	Cycles	Time	C/S
cmp1_st:	2	2	0	127399.00	2405.28	52.97
cmp1_nospec:	5	5	0	349747.50	8391.28	41.68
cmp1_mt:	15	15	0	684702.50	20884.47	32.79
cmp1_mmu:	9	9	0	245845.50	7335.27	33.52
cmp1_lsu:	5	5	0	190447.50	5876.04	32.41
cmp1_fast_idtl b:	4	4	0	102978.00	2579.26	39.93
cmp1_fast_fg_u:	5	5	0	109217.50	2205.12	49.53
cmp1_fast_ex_u:	6	6	0	140307.00	3639.62	38.55
ALL:	51	51	0	1950644.50	53316.34	36.59

If your `report.log` file displays a similar status, you have successfully completed running a mini-regression for the OpenSPARC T2 processor.

▼ Run Your First Synthesis

The command to run a synthesis is `rsyn`. For example, to run a synthesis for one of the modules called `efu`, type:

```
% rsyn efu
```

This command runs a synthesis for the `efc` block and creates gate level netlists under the `$DV_ROOT/design/sys/iop/efu/synopsys/gate` directory.

The synthesis flow and scripts are described in more detail in [Chapter 4](#).

OpenSPARC T2 Design Implementation

This chapter gives details on the following topics:

- [OpenSPARC T2 Design](#)
- [OpenSPARC T2 Components](#)
- [Module Directory Structure](#)
- [Megacells](#)

2.1 OpenSPARC T2 Design

OpenSPARC T2 is a single chip multi-threaded (CMT) processor. OpenSPARC T2 contains eight SPARC physical processor cores. Each SPARC physical processor core has full hardware support for eight strands, two integer execution pipelines, one floating-point execution pipeline, and one memory pipeline. The floating-point and memory pipelines are shared by all eight strands. The eight strands are hard-partitioned into two groups of four, and the four strands within a group share a single integer pipeline. While all eight strands run simultaneously, at any given time at most two strands will be active in the physical core, and those two strands will be issuing either a pair of integer pipeline operations, an integer operation and a floating-point operation, an integer operation and a memory operation, or a floating-point operation and a memory operation. Strands are switched on a cycle-by-cycle basis between the available strands within the hard-partitioned group of four using a least recently issued priority scheme. When a strand encounters a long-latency event, such as a cache miss, it is marked unavailable and instructions will not be issued from that strand until the long-latency event is resolved. Execution of the remaining available strands will continue while the long-latency event of the first strand is resolved.

Each SPARC physical core has a 16 KB, 8-way associative instruction cache (32-byte lines), 8 Kbytes, 4-way associative data cache (16-byte lines), 64-entry fully-associative instruction TLB, and 128-entry fully associative data TLB that are shared by the eight strands. The eight SPARC physical cores are connected through a crossbar to an on-chip unified 4 Mbyte, 16-way associative L2 cache (64-byte lines). The L2 cache is banked eight ways to provide sufficient bandwidth for the eight SPARC physical cores. The L2 cache connects to four on-chip DRAM controllers, which directly interface to a pair of fully buffered DIMM (FBD) channels. In addition, an on-chip PCI-EX controller, two 1-Gbit/10-Gbit Ethernet MACs, and several on-chip I/O-mapped control registers are accessible to the SPARC physical cores. Traffic from the PCI-EX port coherently interacts with the L2 cache.

Note – OpenSPARC T2 currently does not include PCI-Express design implementation due to current legal restrictions. Equivalent model may be available in the subsequent releases of OpenSPARC T2.

A block diagram of the OpenSPARC T2 chip is shown in [FIGURE 2-1](#)

FIGURE 2-1 OpenSPARC T2 Chip Block Diagram

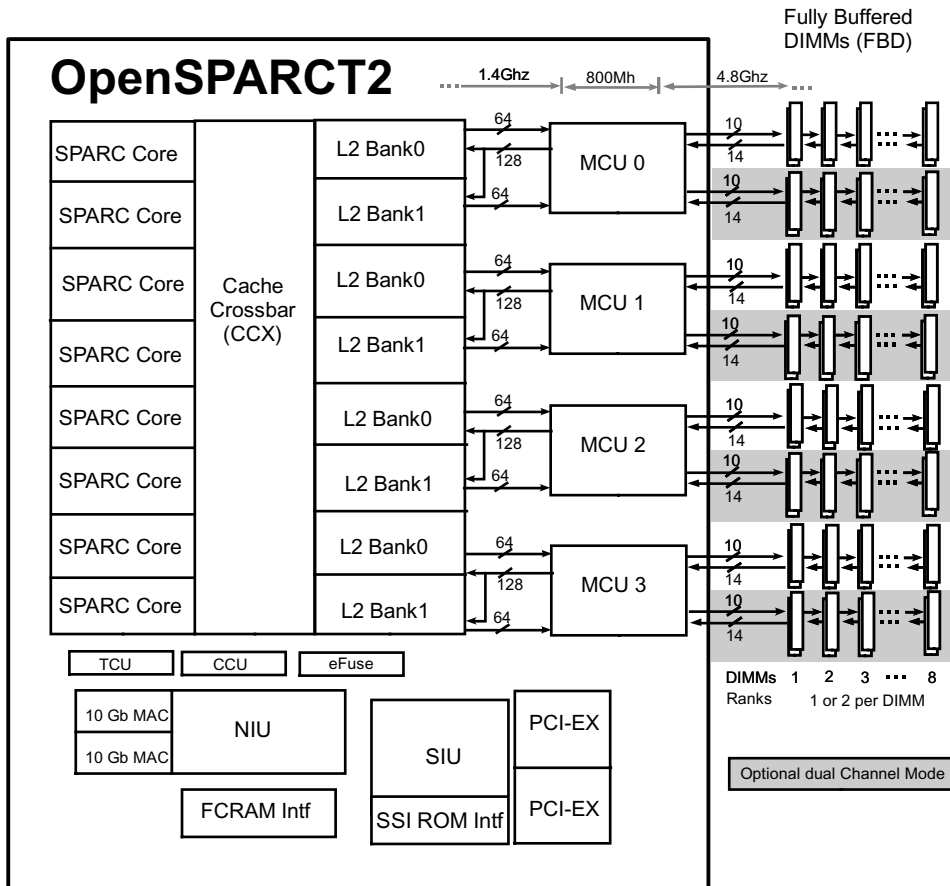

2.2 OpenSPARC T2 Components

This section describes each component in OpenSPARC T2.

2.2.1 SPARC Physical Core

Each SPARC physical core has hardware support for eight strands. This support consists of a full register file (with eight register windows) per strand, with most of the ASI, ASR, and privileged registers replicated per strand. The eight strands share the instruction and data caches and TLBs. An auto-demap feature is included with the TLBs to allow the multiple strands to update the TLB without locking.

There is a single floating-point unit within each SPARC physical core for a total of 8 on a T2 chip. Each floating-point unit is shared by all eight strands and fully pipelined. The theoretical floating-point bandwidth is 11 Giga Floating Point Ops (GFlops) per second making the T2 an excellent floating-point processor.

Detailed information on the core processor is provided in *OpenSPARC T2 Core Microarchitecture Specification*.

2.2.2 SPARC System-On Chip (SoC)

Each SPARC physical core is supported by system on chip hardware components.

Information on each of the functioning units of the system on chip of OpenSPARC T2 are provided in the following chapters of *OpenSPARC T2 System-On Chip (SoC) Microarchitecture Specification*.

2.3 Module Directory Structure

The Verilog RTL for the OpenSPARC T2 processor is in the `$(DV_ROOT)/design/sys/iop/cpu` directory. The top level verilog module for the OpenSPARC T2 processor is called “cpu”. All the top-level modules that make up that RTL, and their locations, are listed in [TABLE 2-1](#).

TABLE 2-1 OpenSPARC T2 Top-Level Clusters

Module Name	Type	Number of Instances	Instance Names	Directory Location under <code>\$(DV_ROOT)/design/sys/iop</code>	Description
ccu	cluster	1	ccu	ccu	Clock Control Unit
ccx	Cluster	1	ccx	ccx	CPU-Cache Cross bar
db0	Cluster	1	db0	db0	Debug Unit
db1	Cluster	1	db1	db1	Debug Unit
dmu	cluster	1	dmu	dmu	Data Management Unit
efu	Cluster	1	efu	efu	e-Fuse Cluster
fsr	cluster	1	fsr	fsr	FBDIMM Serdes macro
fsr_bottom	cluster	1	fsr_bottom	fsr_bottom	FBDIMM Serdes Macro
fsr_left	cluster	1	fsr_left	fsr_left	FBDIMM Serdes Macro
fsr_right	cluster	1	fsr_right	fsr_right	FBDIMM Serdes Macro
l2b	Cluster	8	l2b[0-7]	l2b	L2\$ bank
l2t	Cluster	8	l2t[0-7]	l2t	L2 \$ tag
l2d	Cluster	8	l2d[0-7]	l2d	L2 \$ data
mcu	cluster	4	mcu[0-3]	mcu	Memory Controller
mio	cluster	1	mio	mio	Miscellaneous I/O
ncu	cluster	1	ncu	ncu	Non-cacheable Unit

TABLE 2-1 OpenSPARC T2 Top-Level Clusters (*Continued*)

Module Name	Type	Number of Instances	Instance Names	Directory Location under \$DV_ROOT/design/sys/iop	Description
rst	cluster	1	rst	rst	Reset Unit
sii	cluster	1	sii	sii	System Interface Unit - Inbound
sio	cluster	1	sio	sio	System Interface Unit - Outbound
spc	Cluster	8	spc[0-7]	spc	SPARC CPU core
tcu	cluster	1	tcu	tcu	Trap Control Unit
esr	cluster	1	esr	esr	Ethernet SerDes model
mac	cluster	1	mac	mac	Ethernet MAC
tds	cluster	1	tds	tds	Ethernet Transmit Data Path
rdp	cluster	1	rdp	rdp	Ethernet Receive Data Path
rtx	cluster	1	rtx	rtx	Ethernet Receive and Transmit

2.4 Megacells

The OpenSPARC T2 design contains many megacells, which are custom blocks for static random access memory (SRAMs), translation lookaside buffer (TLB), TAGs, Level 2 Cache, and so on. These megacells are instantiated in the top-level clusters. The detailed descriptions of all megacells, including their function descriptions, I/O lists, block diagrams, and timing diagrams, are in the *OpenSPARC T2 Megacell Specification*.

OpenSPARC T2 Verification Environment

This chapter describes the following topics:

- [OpenSPARC T2 Verification Environment](#)
- [Running a Regression](#)
- [PLI Code Used For the Test Bench](#)
- [Verification Test File Locations](#)

3.1 OpenSPARC T2 Verification Environment

The OpenSPARC T2 verification environment is a highly automated environment. With a simple command, you can run the entire regression suite for the OpenSPARC T2 processor, containing hundreds of tests. With a second command, you can check the results of the regression.

The OpenSPARC T2 Design and Verification package comes with four test bench environments: `cmp1`, `cmp8`, `fc1` and `fc8`.

The `cmp1` environment consists of:

- One SPARC CPU core
- Cache
- Memory
- Crossbar

The `cmp1` environment does not have an I/O subsystem.

The `cmp8` environment consists of:

- Eight SPARC CPU cores
- Cache
- Memory
- Crossbar

The `cmp8` environment does not have an I/O subsystem.

The `fc1` environment consists of:

- A full OpenSPARC T2 chip, with one SPARC Core
- Cache
- Memory
- Crossbar
- I/O subsystem

The `fc8` environment consists of:

- A full OpenSPARC T2 chip, including all eight cores
- Cache
- Memory
- Crossbar
- I/O subsystem

The verification environment uses source code in various languages. [TABLE 3-1](#) shows a summary of the types of source code and their uses.

TABLE 3-1 Source Code Types in the Verification Environment

Source Code Language	Used for:
Verilog	Chip design, test bench drivers, and monitors.
Vera	Test bench drivers, monitors, and coverage objects. Use of Vera is optional.
PERL	Scripts for running simulations and regressions.
C and C++	PLI (Programming Language Interface) for Verilog.
SPARC Assembly	Verification tests.

3.2 Running a Regression

For each environment, there is a mini-regression and a full regression. [TABLE 3-2](#) describes the regression groups.

TABLE 3-2 Details of Regression Groups

Regression Group name	Environment	No. of Tests
cmp1_mini_T2	cmp1	6
cmp1_all_T2	cmp1	768
cmp8_mini_T2	cmp8	7
cmp8_all_T2	cmp8	648
fc1_mini_T2	fc1	6
fc1_full_T2	fc1	353
fc8_mini_T2	fc8	17
fc8_full_T2	fc8	535

▼ To Run a Regression

1. Run the `sims` command with your chosen parameters.

For instance, to run a mini-regression for the `cmp1` environment using the VCS simulator, set up the `sims` command as follows:

```
% sims -sys=cmp1 -group=cmp1_mini_T2
```

To run regressions on multiple groups at the same time, specify multiple `-group=` parameters at the same time. For a complete list of command-line options for the `sims` command, see [Appendix A](#).

2. Run the `regreport` command to get a summary of the regression.

```
% regreport $PWD/2007_08_07_0 > report.log
```

3.2.1 What the `sims` Command Does

When running a simulation, the `sims` command performs the following steps:

1. Compiles the design into the `$MODEL_DIR/cmp1` or `$MODEL_DIR/fc8` directory, depending on which environment is being used.
2. Creates a directory for regression called `$PWD/DATE_ID`, where `$PWD` is your current directory, `DATE` is in `YYYY_MM_DD` format, and `ID` is a serial number starting with 0. For example, for the first regression on August07, 2007, a directory called `$PWD/2007_08_07_0` is created. For the second regression run on the same day, the last ID is incremented to become `$PWD/2007_08_07_1`.
3. Creates a `master_diaglist.regression_group` file under the above directory. such as `master_diaglist.cmp1_mini_T2` for the `cmp1_mini_T2` regression group. This file is created based on `diaglists` under the `$DV_ROOT/verif/diag` directory.
4. Creates a subdirectory with the test name under the regression directory created in step 2 above.
5. Creates a `sim_command` file for the test based on the parameters in the `diaglist` file for the group.
6. Executes `sim_command` to run a Verilog simulation for the test. If the `-sas` option is specified for the test, it also runs the SPARC Architecture Simulator (SAS) in parallel with the Verilog simulator. The results of the Verilog simulation are compared with the SAS results after each instruction.

The `sim_command` command creates many files in the test directory. Following are the sample files in the test directory:

<code>diag.ev</code>	<code>diag.s</code>	<code>raw_coverage</code>	<code>seeds.log</code>
<code>status.log</code>	<code>vcs.log.gz</code>	<code>diag.exe.gz</code>	<code>midas.log</code>
<code>sas.log.gz</code>	<code>sims.log</code>	<code>symbol.tbl</code>	<code>vcs.perf.log</code>

The `status.log` file has a summary of the status, where the first line contains the name of the test and its status (PASS/FAIL).

<code>Rundir: tlu_rand05_ind_03:cmp1_st:cmp1_mini_T2:0</code>	<code>PASS</code>
---	-------------------

7. Repeats steps 4 to 6 for each test in the regression group.

3.3 PLI Code Used For the Test Bench

Verilog's PLI (Programming Language Interface) is used to drive and monitor the simulations of the OpenSPARC T2 design. There are eight different directories for PLI source code. Some PLI code is in C language, and some is in C++ language. [TABLE 3-3](#) gives the details of PLI code directories and VCS libraries.

TABLE 3-3 PLI Source Code and Object Libraries

PLI name	Source code location under \$DV_ROOT	VCS object library name	Description
iob	verif/env/common/pli/cache	libiob.a	Cache warming routines
mem	model/infineon	libbwmem_pli.a	Memory read/write
socket	verif/env/common/pli/socket	libsocket_pli.a	Sockets to SAS
utility	verif/env/common/pli/utility	libbwutility_pli.a	Utility functions
monitor	verif/env/common/pli/monitor/c	libmonitor_pli.a	Various
global_checker	verif/env/common/pli/global_checker/	libglobal_chkr.a	Various checkers

VCS object libraries are statically linked libraries (.a files) which are linked when VCS compiles the Verilog code to generate a simv executable.

Makefile is provided to compile PLI code. There is a makefile file under \$DV_ROOT/tools/pli directory which will compile static executable (.a file) of the PLI code.

3.4 Verification Test File Locations

The verification or diagnostics tests (diags) for the OpenSPARC T2 processor are written in SPARC assembly language (the file names have a .s extension). Some diagnostics test cases in SPARC assembly are automatically generated by Perl scripts.

The main diaglist for `cmp1` is `cmp1.diaglist`. The main diaglist for `fc8` is `fc8.diaglist`. These main diaglists for each environment also include many other diaglists. The locations of various verification test files are listed in [TABLE 3-4](#).

TABLE 3-4 Verification Test File Directories

Directory	Contents
<code>\$DV_ROOT/verif/diag</code>	All diagnostics, various diagnostic list files with the extension <code>.diaglist</code> .
<code>\$DV_ROOT/verif/diag/assembly</code>	Source code for SPARC assembly diagnostics. More than 1400 assembly test files.
<code>\$DV_ROOT/verif/diag/efuse</code>	EFuse cluster default memory load files.

OpenSPARC T2 Synthesis

This chapter describes the following topics:

- [Synthesis Flow for the OpenSPARC T2 Processor](#)
- [Synthesis Output](#)

The scripts provided in the source code are for the Synopsys Design Compiler.

4.1 Synthesis Flow for the OpenSPARC T2 Processor

There are two types of synthesis scripts:

- One set to run the Synopsys Design Compiler (`rsyn` and `syn_command`)
- One set used as input for the Design Compiler

The main script used to run Synopsys Design Compiler is called `rsyn`. This is a PERL script that calls a second script, `syn_command`, once for each module you are synthesizing. The command-line options for the `rsyn` script are described in [CODE EXAMPLE 4-1](#).

CODE EXAMPLE 4-1 Command-Line Options for rsyn Script

```
rsyn : Run Synthesis for OpenSPARC T2

    -all
        to run synthesis for all blocks
    -h / -help
        to print help
    -syn_q_command='Your job Queue command'
        to specify Job queue command. e.g. specify submit command
        for LSF or GRID
    block_list :
        specify list of blocks to synthesize

Examples:

rsyn -all
rsyn efu
```

Synthesis scripts for most of the modules are provided in the `$DV_ROOT/design` sub-directories. There are no synthesis scripts for the following types of modules:

- Megacell modules (SRAMS, TLB, TAG, Cache, etc.)
- Top-level hierarchical modules

Synopsys scripts, their locations, and their descriptions are listed in [TABLE 4-1](#).

TABLE 4-1 Synthesis Script Details

Script name	Location	Description
<code>run.scr</code>	<code>\$DV_ROOT/design/sys/synopsys/script</code>	Main synthesis script that calls <code>user_cfg.scr</code>
<code>project_sparc_cfg.scr</code>	<code>\$DV_ROOT/design/sys/synopsys/script</code>	SPARC module-specific synthesis script
<code>project_io_cfg.scr</code>	<code>\$DV_ROOT/design/sys/synopsys/script</code>	I/O module-specific synthesis script
<code>target_lib.scr</code>	<code>\$DV_ROOT/design/sys/synopsys/script</code>	Target library-specific script
<code>user_cfg.scr</code>	<i>Module directory</i> / <code>synopsys/script</code>	Module-specific synthesis script

The top-level Synopsys script, `run.scr`, calls the module-specific script named `user_cfg.scr`. The `user_cfg.scr` script calls the `project_sparc_cfg.scr` script or the `project_io_cfg.scr` script, depending on whether the module belongs to `sparc` or `io`.

The list of all modules with synthesis scripts is in the `$DV_ROOT/design/sys/synopsys/block.list` file. Each module has:

- A `synopsys` directory under the module directory
- A `script` directory under each `synopsys` directory
- The `user_cfg.scr` file under the `script` directory

For example, the `efc` module-specific synthesis script has the following directory path:

```
$DV_ROOT/design/sys/iop/efu/synopsys/script/user_cfg.scr
```

The target library is set to a generic library called `lsi_10k.db` in the `target_lib.scr` script. Modify this file to set your own target library and its required variables.

4.2 Synthesis Output

Running synthesis for a module creates files and directories under the `Module name/synopsys` directory, described in [TABLE 4-2](#).

TABLE 4-2 Synthesis Output

Name	Type	Description
<code>dc_shell.log</code>	File	Log file from running Design Compiler
<code>command.log</code>	File	Command log from running Design Compiler
<code>log</code>	Directory	Area report files from Design Compiler
<code>gate</code>	Directory	Gate netlist generated by Design Compiler
<code>.template</code>	Directory	Template directory used by Design Compiler

Design and Verification Manual Pages

This appendix provides the manual pages for commands used for OpenSPARC T2 design and verification.

A.1 `sims`

NAME

`sims` - Verilog rtl simulation environment and regression script

SYNOPSIS

`sims [args ...]`

Note – Use "=" instead of "space" to separate args and their options.

where args are:

SIMULATION ENV

`-sys=NAME`

`sys` is a pointer to a specific testbench configuration to be built and run. a config file is used to associate the `sys` with a set of default options to build the testbench and run diagnostics on it. the arguments in the config file are the same as the arguments passed on the command line.

`-group=NAME`

group name identifies a set of diags to run in a regression. The presence of this argument indicates that this is a regression run. the group must be found in the diaglist. multiple groups may be specified to be run within the same regression.

Note – If `-sys=NAME` option is specified then `NAME.diaglist` is used as root diaglist instead of the master diaglist.

`-group=NAME -alias=ALIAS`

this combination of options gets the diag run time options from the diaglist based on the given group and alias. the group must be found in the diaglist. the alias is made up of `diag_alias:name_tag`. only one group should be specified when using this command format.

VERILOG COMPILATION RELATED

`-sim_q_command="command"`

defines which job queue manager command to use to launch jobs. Defaults to `/bin/sh` and runs simulation jobs on the local machine.

`-vcs_build/-novcs_build`

builds a vcs model and the vera testbench. defaults to off.

`-vcs_build_args=OPTION`

vcs compile options. multiple options can be specified using multiple such arguments.

`-vcs_clean/-novcs_clean`

wipes out the model directory and rebuilds it from scratch. defaults to off.

`-vcs_full64`

sets the vcs `-full64` compile flag so that the compiler is a 64 bit executable, and produces a 64 bit executable simv. will use the 64 bit version of vera, and link in the 64 bit versions of `0in`, `debussy`, and `denali` tools.

`-vcs_use_2state/-novcs_use_2state`

builds a 2state model instead of the default 4state model. this defaults to off.

`-vcs_use_initreg/-novcs_use_initreg`

initialize all registers to a valid state (1/0).

this feature works with `-tg_seed` to set the seed of the random initialization. this defaults to off.

`-vcs_use_fsdb/-novcs_use_fsdb`

use the debussy fsdb pli and include the dump calls in the testbench. this defaults to on.

`-vcs_use_vcsd/-novcs_use_vcsd`

use the vcs direct kernel interface to dump out debussy files. this defaults to on.

`-vcs_use_vera/-novcs_use_vera`

compile in the vera libraries. if `-vcs_use_ntb` and `-vcs_use_vera` are used, `-vcs_use_ntb` wins. this defaults to off.

`-vcs_use_ntb/-novcs_use_ntb`

enable the use of NTB when building model (simv) and running simv. if `-vcs_use_ntb` and `-vcs_use_vera` are used, `-vcs_use_ntb` wins. this defaults to off.

`-vcs_use_rad/-novcs_use_rad`

use the `+rad` option when building a vcs model (simv). defaults to off.

`-vcs_use_sdf/-novcs_use_sdf`

build vcs model (simv) with an sdf file. defaults to off.

`-vcs_use_radincr/-novcs_use_radincr`

use incremental `+rad` when building a vcs model (simv). defaults to off. this is now permanently disabled as synopsys advises against using it.

`-vcs_use_cli/-novcs_use_cli`

use the `+cli -line` options when building a vcs model (simv). defaults to off.

use this switch, in conjunction with `-nosimslog` during runtime if you need to pass `ctrl-c` to the vcs/axis model and continue with CLI activity.

Use this with VCS versions before 2006.

`-vcs_use_ucli/-novcs_use_ucli` (Unified cli)

use the `-debug_all` option when building a vcs model (simv). defaults to off.

use this switch, in conjunction with `-nosimslog` during runtime if you need to pass `ctrl-c` to the `vcs/axis` model and continue with UCLI activity.

At runtime, use `-vcs_run_arg=-ucli` to get the UCLI at time zero, or use `-vcs_run_arg=-gui` to get the UCLI GUI at time zero. At runtime, use `-vcs_run_arg=-tbug` to get NTB debug in the GUI.

Use this with VCS versions 2006 and up.

`-flist=FLIST`

full path to flist to be appended together to generate the final verilog flist. multiple such arguments may be used and each flist will be concatenated into the final verilog flist used to build the model.

`-graft_flist=GRAFTFILE`

GRAFTFILE is the full path to a file that lists each verilog file that will be grafted into the design. the full path to the verilog files must also be given in the GRAFTFILE.

`-vfile=FILE`

verilog file to be included into the flist

`-config_rtl=DEFINE`

each such parameter is place as a ``define` in `config.v` to configure the model being built properly. this allows each testbench to select only the rtl code that it needs from the top level rtl file (`ciop.v` in `blackwidow`).

`-model=NAME`

the name of a model to be built. the full path to a model is `MODEL_DIR/model/vcs_rel_name`.

`-vcs_rel_name=NAME`

specify the release of the model to be built. the full path to a model is `MODEL_DIR/model/vcs_rel_name`.

VERA/NTB COMPILATION RELATED

VERA and NTB share all of the vera options except a few. See NTB RELATED.

`-vera_build/-novera_build`

builds the vera/ntb testbench. default on.

`-vera_clean/-novera_clean`

performs a `gmake clean` on the vera/ntb testbench before building the model. defaults to off.

`-vera_build_args=OPTION`

vera/NTB testbench compile time options.

Multiple options can be specified using multiple such options. these are passed as arguments to the gmake call when building the vera/NTB testbench.

(Eg: `-vera_build_args=VERA_SYS_DEFS="-DSPC_BENCH -DGATESIM"`)

For NTB, `-vera_build_args=NTB_BUILD_ARGS="+error+10 -ntb_define ABCD"` can be used to add something directly to the `"vcs -ntb_cmp"` command. For the `-ntb_lib` option, `NTB_BUILD_ARGS` will affect both the `vshell` and `bench+diag` builds. See `-vera_diag_args` to not affect the `vshell` build.

`-vera_diag_args=OPTION`

vera/ntb diag compile time options.

Multiple options can be specified using multiple such options. For Vera, these args are appended to the `"vera -cmp ..."` command for the diag only.

(Eg: `-vera_diag_args="-max_error 10"` or
`-vera_diag_args=-DNCU_ACK_DLY1=100`)

For NTB, these args are passed as arguments to the gmake call as `NTB_DIAG_ARGS=" ..."` to be part of the NTB `bench+diag` compile. These `NTB_DIAG_ARGS` are appended to the `"vcs -ntb_cmp"` command when making the `libtb.so` so they better be legal in that context. For NTB, these args really affect the entire `bench` build, not just the `diag`, BUT they they do not affect the `vshell` build.

(Eg. `-vera_diag_args+=error+10` or
`-vera_diag_args="-ntb_define NCU_ACK_DLY1=100"`)

`-vera_dummy_diag=PATH`

This option is used to give vera/NTB a path to a default `diag` or `diag class` (or a default program top if using RVM) that can be used for building purposes before an actual `diag` is chosen (NTB build of `vshell` file before regression for example).

Also, some benches may run both `asm` and vera diags but the vera diags are only run sometimes. In this case, you need a dummy vera testcase class/program top to fill in when an actual vera `diag` is not being used for that run (aka the sometimes `diag` problem). If your openVera code refers to a testcase class, you better have one even if it does nothing else you will not be able to build. The dummy lets you build. If your `diag` is implemented as the program top (RVM) then the dummy must have `#includes` for ALL of your vera interfaces or your `vshell` will be broken.

Whenever the actual vera/NTB diag is specified, the dummy is automatically **not** used (at regression time for example). The vera_dummy_diag should be specified in the bench config file. This option applies to Vera and NTB (but NTB only when using the -ntb_lib option).

- vera_pal_diag_args=OPTION
vera/ntb pal diag expansion options
(i.e. "pal OPTIONS -o diag.vr diag.vrpal")
multiple options can be specified using multiple such arguments.
- vera_proj_args=OPTION
vera proj file generation options. multiple options can be specified using multiple such arguments.
- vera_vcon_file=ARG
name of the vera vcon file that is used when running the simulation.
- vera_cov_obj=OBJ
this argument is passed to the vera Makefile as a OBJ=1 and to vera as -DOBJ to enable a given vera coverage object. multiple such arguments can be specified for multiple coverage objects.
- vera_gmake/-novera_gmake
this argument optionally lets the flow skip running gmake for the vera/NTB build, while maintaining other operations within the -vera_build flow. default ON (execute gmake)

NTB RELATED

NTB and VERA share all of the vera options except these:

- vcs_use_ntb/-novcs_use_ntb
enable the use of NTB (compiled vera) rather than the conventional Vera. if -vcs_use_ntb and -vcs_use_vera are used at once, then -vcs_use_ntb wins. defaults to off.
- ntb_lib/-nontb_lib
enables the NTB 2 part compile where the openVera files get compiled separately into a libtb.so file which is dynamically loaded by vcs at runtime. The libtb.so file is built by the Vera/NTB Makefile, not sims. Use the Makefile to affect the build. If not using -ntb_lib, sims will build VCS and the openVera files together in one pass (uses Makefile to affect that build as well). default is off.

The ntb_lib method is know as the NTB LIB method. When not

using this ntb_lib method, the ALL IN ONE method is used.

The NTB LIB method allows the bench to run unique openVera diags that are separate from the bench (via a diaglist if desired).

The NTB ALL IN ONE method does not allow the bench to run unique openVera diags that are separate from the bench. Use this for benches that do not run openVera diags (perhaps the bench only runs asm diags)

VERILOG RUNTIME RELATED

-vera_run/-novera_run

runs the vcs simulation and loads in the vera proj file or the ntb libtb.so file. defaults to on.

-vcd/-novcd

signals the bench to dump in VCD format

-vcdfile=filename

the name of the vcd dump file. if the file name starts with a "/", that is the file dumped to, otherwise, the actual file is created under tmp_dir/vcdfile and copied back to the current directory when the simulation ends. use "-vcdfile=`pwd`/filename" to force the file to be written in the current directory directly (not efficient since dumping is done over network instead of to a local disk).

-vcs_run/-novcs_run

runs the vcs simulation (simv). defaults to off.

-vcs_run_args=OPTION

vcs (simv) runtime options. multiple options can be specified using multiple such arguments.

The order of vcs_run_args (plusargs) given to simv is:

- args embedded in diag (using !SIMS+ARGS: ..), if any
- args given in the command line, if any
- args from diaglist : alias definition, if any
- args from diaglist : <runargs>..</runargs>, if any
- args from the config file, if any

-vcs_finish=TIMESTAMP

forces vcs to finish and exit at the specified timestamp.

-fast_boot/-nofast_boot

speeds up booting when using the ciop model. this passes the +fast_boot switch to the simv run and the -sas_run_args=-DFAST_BOOT and -midas_args=-DFAST_BOOT to sas and midas. Also sends

-DFAST_BOOT to the diaglist and config file preprocessors.

-debussy/-nodebussy
enable debussy dump. this must be implemented in the testbench to work properly. defaults to off.

-start_dump=START
start dumping out a waveform after START number of units

-stop_dump=STOP
stop dumping out a waveform after STOP number of units

-fsdb2vcd
runs fsdb2vcd after the simulation has completed to generate a vcd file.

-fsdbfile=filename
the name of the debussy dump file.
If the file name starts with a "/", that is the file dumped to, otherwise, the actual file is created under tmp_dir/fsdbfile and copied back to the current directory when the simulation ends. Use "-fsdbfile='pwd'/filename" to force the file to be written in the current directory directly (not efficient since dumping is done over network instead of to a local disk).

-fsdbDumplimit=SIZE_IN_MB
max size of Debussy dump file. minimum value is 32MB.
Latest values of signal values making up that size is saved.

-fsdb_glitch
turn on glitch and sequence dumping in fsdb file. this will collect glitches and sequence of events within time in the fsdb waveform. beware that this will cause the fsdb file size to grow significantly. this is turned off by default. this option effectively does this:
setenv FSDB_ENV_DUMP_SEQ_NUM 1
setenv FSDB_ENV_MAX_GLITCH_NUM 0

-rerun
rerun the simulation from an existing regression run directory.

-overwrite
overwrite current run dir when doing a -rerun. default is to create a rerun_<n> subdir for reruns.

-post_process_cmd=COMMAND
post processing command to be run after vcs (simv) run completes

-pre_process_cmd=COMMAND
pre processing command to be run before vcs (simv) run starts

`-use_denalirc=FILE`
use FILE as the .denalirc in the run area. Default copies
env_base/.denalirc

SUNV OPTIONS

`-sunv_run/-nosunv_run`
runs the sunv program to convert structural files,
e.g. <file>.sv to verilog. defaults to off.

`-sunv_args=ARGS`
sunv options. Multiple options can be specified using
multiple such arguments. In addition, a portion of
these arguments can be provided in a file using the
sunv option `-optfile=<file>`.

`-sunv_use_nonprim/-nosunv_use_nonprim`
use a list to hold primitives that we want to remove from the
default primitive.list. defaults to off.

`-sunv_nonprim_list=FILE`
name of file holding the list of primitives that we want to remove.
this is only used if `-sunv_use_nonprim` is specified.

VLINT OPTIONS

`-vlint_run/-novlint_run`
runs the vlint program. defaults to off.

`-vlint_args`
vlint options. The <sysName>.config file can contain
the desired vlint arguments, or they can also be given on
the command line. Typically the `-vlint_compile` is given
on the command line.

vlint also requires identification of a rules deck.

`-illust_run`
run illust after x2e

`-illust_args`
illust options

`-vlint_top`
top level module on which to run vlint

VERIX OPTIONS

`-verix_run/-noverix_run`

runs the verix program. defaults to off.

-verix_libs
specify the library files to add to the vlist

-verix_args
verix template options. The <sysName>.config file can contain these desired verix arguments

verix also requires <top>.verix.tmplt in the config dir.

-verix_top
top level module on which to run verix

THARAS HAMMER RELATED

-hcs_build
build a model to be run on the Hammer Hardware Accelerator.

-hcs_build_args
build arguments for Hammer Hardware Accelerator

-hcs_run
run a model on the Hammer Hardware Accelerator.

-hcs_run_args
run arguments for the Hammer Hardware Accelerator.

-hcs_drm_tokens
tokens for drmsubmit licenses

AXIS RELATED

-axis_build
build a model to be run on the Axis Hardware Accelerator.

-axis_build_args
build arguments for Axis Hardware Accelerator

-axis_run
run a model on the Axis Hardware Accelerator.

-axis_run_args
run arguments for the Axis Hardware Accelerator.

PALLADIUM RELATED

-palladium_build

build a model to be run on the palladium Hardware Accelerator.

- palladium_build_args
build arguments for palladium Hardware Accelerator
- palladium_run
run a model on the palladium Hardware Accelerator.
- palladium_run_args
run arguments for the palladium Hardware Accelerator.

ZEROIN RELATED

- zeroIn_checklist
run 0in checklist
- zeroIn_build
build 0In pli for simulation into vcs model
- zeroInSearch_build
build 0in search pli for simulation into vcs model
- zeroIn_build_args
additional arguments to be passed to the 0in command
- zeroIn_dbg_args
additional debug arguments to be passed to the 0in shell

SAS/SIMICS RELATED

- sas/-nosas
run architecture-simulator. If vcs_run option is OFF, simulation is sas-only. If vcs_run option is ON, sas runs in lock-step with rtl. default to off.
- sas_run_args=DARGS
Define arguments for sas.

TCL/TAP RELATED

- tcl_tap/-notcl_tap
run tcl/expect TAP program. If vcs_run option is OFF, simulation is tcl-only. If vcs_run option is ON, tcl runs in lock-step with rtl. default to off.

Note – You must compile with `-tcl_tap` as well, to enable to enable functions that are needed for running with `tcl`

`-tcl_tap_diag=diagname`
Define top level `tcl/expect` diag name.

MIDAS RELATED

`midas` is the diag assembler

`-midas_args=DARGS`
arguments for `midas`. `midas` creates memory image and user-event files from the assembly diag.

`-midas_only`
Compile the diag using `midas` and exit without running it.

`-midas_use_tgseed`
Add `-DTG_SEED=tg_seed` to `midas` command line. Use `-tg_seed` to set the value passed to `midas` or use a random value from `/dev/random`.

PCI

`pci` is the tomatillo pci bus functional model

`-pci_args`
arguments to be passed in to `pci_cmdgen.pl` for generation of a pci random diagnostic.

`-pci/-nopci`
generates a random pci diagnostic using the `-tg_seed` if provided. default is off.

`-tomatillo`
generates a random tomatillo diagnostic using the `-tg_seed` if provided

`-tg_seed`
random generator seed for `pci/tomatillo` random test generators also the value passed to `+initreg+` to randomly initialize registers when `-vcs_use_initreg` is used.

SJM RELATED

`sjm` is the jalapeno jbus bus functional model

`-sjm_args`
arguments to be passed in to `sjm_tstgen.pl` for generation of an `sjm`

random diagnostic.

`-sjm/-nosjm`

generates a random sjm diagnostic using the `-tg_seed` if provided.
default is off.

`-tomatillo`

generates a random tomatillo diagnostic using the `-tg_seed` if provided

`-tg_seed`

random generator seed for sjm/tomatillo random test generators
also the value passed to `+initreg+` to randomly initialize registers
when `-vcs_use_initreg` is used.

EFCGEN

`efcgen.pl` is a script to generate `efuse.img` files (default random),
which is used by the efuse controller after reset.
It is invoked by `-efc`.

`-efc/-noefc`

generates an efuse image file using the `-tg_seed` if provided.
default is off. Random if no `-efc_args` specified.

`-efc_args`

arguments to be passed in to `efcgen.pl` for generation of
an efuse image file.
Default is random efuse replacement for each block.

`-tg_seed`

random generator seed for `efcgen.pl` script
also the value passed to `+initreg+` to randomly initialize
registers when `-vcs_use_initreg` is used.

VCS COVERMETER

`-vcs_use_cm/-novcs_use_cmd`

passes in the `-cm` switch to `vcs` at build time and `simv` at runtime
default to off.

`-vcs_cm_args=ARGS`

argument to be given to the `-cm` switch

`-vcs_cm_cond=ARGS`

argument to be given to the `-cm_cond` switch.

`-vcs_cm_config=ARGS`

argument to be given to the `-cm_hier` switch

`-vcs_cm_fsmcfg=ARGS`
argument to be given to the `-cm_fsmcfg` switch
specifies an FSM coverage configuration file

`-vcs_cm_name=ARGS`
argument to be given to the `-cm_name` switch. defaults to `cm_data`.

DFT

`-dftvert`
modifies the sims flow to accomodate dftvert. this skips compiling
the vera testbench and modifies the simv command line at runtime.

CDMS

`-cdms_rel_name=CDMSREL`
specify the cdms++ release that must be collected for this
model.

`-diff_cdms_rel`
performs a diff_release of CDMSREL from `-cdms_rel_name` and
records it in a file called `diff_rel.log` lcoated in the model
area. This file is copied into each run directory from the
model area at runtime.

`-diff_cdms_curr`
uses the current (in localdir) release of CDMSREL for the
`diff_release` command. Ignored if `-cdms_rel_name` and `-diff_cdms_rel`
are not specified.

MISC

`-regress`
pretend this is a regression and run the job in `DRMJOBSCRATCHSPACE`
instead of the launch directory. useful with `-indrm` and
`-interactive` options and single jobs. automatically added for
regressions.

`-nobuild`
this is a master switch to disable all building options.
there is no such thing as `-build` to enable all build options.

`-copyall/-nocopyall`
copy back all files to launch directory after passing regression run.
Normally, only failing runs cause a copy back of files.
Default is off.

`-copyall/-nocopyall`
copy back all files to launch directory after passing regression run. Normally, only failing runs cause a copy back of files.
Default is off.

`-copydump/-nocopydump`
copy back dump file to launch directory after passing regression run. Normally, only failing runs cause a copy back of non-log files. The file copied back is `vcs.fsdb`, or `vcs.vcd` if `-fsdb2vcd` option is set.
Default is off.

`-tarcopy/-notarcopy`
copy back files using 'tar'. This only works in `copyall` or in the case the simulations 'fails' (per sims' determination).
Default is to use 'cp'.

`-diag_pl_args=ARGS`
If the assembly diag has a Perl portion at the end, it is put into `diag.pl` and is run as a Perl script. This allows you to give arguments to that Perl script. The arguments accumulate, if the option is used multiple times.

`-pal_use_tgseed`
Send `'-seed=<tg_seed_value>` to pal diags. Adds `-pal_diag_args=-seed=``tg_seed` to midas command line, and `-seed=``tg_seed` to pal options (vrpal diags). Use `-tg_seed` to set the value passed to midas or use a random value from `/dev/random`.

`-parallel`
when specifying multiple groups for regressions this switch will submit each group to DReAM to be executed as a separate regression. this has the effect of speeding up regression submissions.
NOTE: This switch must not be used with `-indrm`

`-reg_count=COUNT`
runs the specified group multiple times in regression mode. this is useful when we want to run the same diag multiple times using a different random generator seed each time or some such.

`-regress_id=ID`
specify the name of the regression

`-report`
This flag is used to produce a report of a an old or running regression. With `-group` options, `sims` produces the report after the regression run. Report for the previous

regression run can be produced using `-regress_id=ID` option along with this option,

`-finish_mask=MASK`

masks for vcs simulation termination. Simulation terminates when it hits 'good_trap' or 'bad_trap'. For multithread simulation, simulation terminates when any of the thread hits bad_trap, or all the threads specified by the finish_mask hits the good_trap.

example: `-finish_mask=0xe`

Simulation will be terminated by good_trap, if thread 1, 2 and 3 hits the good_trap.

`-stub_mask=MASK`

mask for vcs simulation termination. Simulation ends when the stub driving the relevant bit in the mask is asserted. This is a hexadecimal value similar to `-finish_mask`

`-wait_cycle_to_kill=VAL`

passes a `+wait_cycle_to_kill` to the simv run. a testbench may chose to implement this plusarg to delay killing a simulation by a number of clock cycles to allow collection of some more data before exiting (e.g. waveform).

`-rtl_timeout`

passes a `+TIMEOUT` to the simv run.
sets the number of clock cycles after all threads have become inactive for the diag to exit with an error. if all threads hit good trap on their own the diag exits right away. if any of the threads is inactive without hitting good trap/bad trap the `rtl_timeout` will be reached and the diag fails. default is 1000. this is only implemented in the cmp based testbenches.

`-max_cycle`

passes a `+max_cycle` to the simv run.
sets the maximum number of clock cycle that the diag will take to complete. the default is 30000. if `max_cycle` is hit the diag exits with a failure. not all testbenches implement this feature.

`-norun_diag_pl`

Does not run `diag.pl` (if it exists) after simv (vcs) run. Use this option if, for some reason, you want to run anexisting assembly diag without the Perl part that is in the original diag.

`-nosaslog`

turns off redirection of sas stdout to the `sas.log` file.
use this option when doing interactive runs with sas.

`-nosimslog`
turns off redirection of stdout and stderr to the `sims.log` file. use this option in conjunction with `-vcs_use_cli` or `-vcs_use_ucli` to get to the cli prompt when using vcs or to see a truncated `vcs.log` file that exited with an error. this must be used if you want control-c to work while vcs is running.

`-nogzip`
turns off compression of log files before they are copied over during regressions.

`-version`
print version number.

`-help`
prints this

IT SYSTEM RELATED

`-use_iver=FILE`
full path to iver file for frozen tools

`-use_sims_iver/-nouse_sims_iver`
For reruns of regression tests only, use `sims.iver` to choose TRE tool versions saved during original regression run. Defaults to true.

`-use_cdms_iver/-nouse_cdms_iver`
Uses the frozen iver file located under `DV_ROOT` if present. This defaults to true. This has no effect if an iver file is not found under the `cdms` tree.

`-dv_root=PATH`
absolute path to design root directory. this overrides `DV_ROOT`.

`-model_dir=PATH`
absolute path to model root directory. this overrides `MODEL_DIR`.

`-tmp_dir=PATH`
path where temporary files such as debussy dumps will be created

`-sims_config=FILE`
full path to sims config file

`-sims_env=ENVAR=value`
force sims to set `ENVAR` variable to specified value.

`-env_base=PATH`

this specifies the root directory for the bench environment. it is typically defined in the bench config file. It has no default.

`-config_cpp_args=OPTION`

this allows the user to provide CPP arguments (defines/undefines) that will be used when the testbench configuration file is processed through cpp. Multiple options are concatenated together.

`-result_dir=PATH`

this allows the regression run to be launched from a different directory than the one sims was launched from. defaults to PWD.

`-diaglist=FILE`

full path to diaglist file

`-diaglist_cpp_args=OPTION`

this allows the user to provide CPP arguments (defines/undefines) that will be used when the diaglist file is processed through cpp. Multiple options are concatenated together.

`-asm_diag_name=NAME`

`-tpt_diag_name=NAME`

`-tap_diag_name=NAME`

`-vera_diag_name=NAME`

`-vera_config_name=NAME`

`-efuse_image_name=NAME`

`-image_diag_name=NAME`

`-sjm_diag_name=NAME`

`-pci_diag_name=NAME`

name of the diagnostic to be run.

`-asm_diag_root=PATH`

`-tpt_diag_root=PATH`

`-tap_diag_root=PATH`

`-vera_diag_root=PATH`

`-vera_config_root=PATH`

`-efuse_image_root=PATH`

`-image_diag_root=PATH`

`-sjm_diag_root=PATH`

`-pci_diag_root=PATH`

absolute path to diag root directory. sims will perform a find from here to find the specified type of diag. if more than one instance of the diag name is found under root sims exits with an error. this option can be specified multiple times to allow multiple roots to be searched for the diag.

```

-asm_diag_path=PATH
-tpt_diag_path=PATH
-tap_diag_path=PATH
-vera_diag_path=PATH
-vera_config_path=PATH
-efuse_image_path=PATH
-image_diag_path=PATH
-sjm_diag_path=PATH
-pci_diag_path=PATH
    absolute path to diag directory. sims expects the specified
    diag to be in this directory. the last value of this option
    is the one used as the path.

```

ClearCase

```

-clearcase
assume we are in ClearCase environment for setting DV_ROOT and
launching DREAM commands. default is off (CDMS++ version control)

-noclearcase
force clearcase option off

-cc_dv_root=PATH
    ClearCase path to design root directory. this overrides CC_DV_ROOT.

```

ENV VARIABLES

sims sets the following ENV variables that may be used with pre/post processing scripts, and other internal tools:

TABLE A-1 Environment Variables

Environment Variable	Description
ASM_DIAG_NAME	Contains the assembly diag name.
SIMS_LAUNCH_DIR	Path to launch directory where sims is running the job. Useful when job is run in dream scratch space.
VERA_LIBDIR	Dir where Vera/NTB files are compiled or results are stored.
DV_ROOT	-dv_root if specified
MODEL_DIR	-model_dir if specified
TRE_SEARCH	Based on -use_iver, -use_cdms_iver -use_sims_iver

TABLE A-1 Environment Variables

Environment Variable	Description
DENALI	Based on configsrch
VCS_HOME	Based on configsrch
VERA_HOME	Based on configsrch

PLUSARGS

+args are not implemented in sims. they are passed directly to vcs at compile time and simv at runtime. the plusargs listed here are for reference purposes only.

- +STACK_DIMM 32 bits physical address space - default is 31 bits
- +STACK_DIMM +RANK_DIMM 33 bits physical address space - default is 31 bits
- +max_cycle see -max_cycle
- +TIMEOUT see -rtl_timeout
- +vcs+finish see -vcs_finish
- +wait_cycle_to_kill see -wait_cycle_to_kill

DESCRIPTION

sims is the frontend for vcs to run single simulations and regressions

How To Build models

Build a model using DV_ROOT as design root

```
sims -sys=cmp -vcs_build
```

Build the vera testbench only using DV_ROOT as design root

```
sims -sys=cmp -vera_build
```

Build a model from any design root

```
sims -sys=cmp -vcs_build -dv_root=/home/regress/2002_06_03
```

Build a graft model from any design root

```
sims -sys=cmp -vcs_build -dv_root=/model/2002_06_03  
-graft_flist=/regress/graftfile
```

Build a model and re-build the vera

```
sims -sys=cmp -vcs_build -vera_clean
```

Build a model and turn off incremental compile

```
sims -sys=cmp -vcs_build -vcs_clean
```

Build a model with a given name

```
sims -sys=cmp -vcs_build -vcs_rel_name=mymodel
```

How To Run Models

Run a diag with default model

```
sims -sys=cmp -vcs_run diag.s
```

Run a diag with a specified model

```
sims -sys=cmp -vcs_rel_name=mymodel -vcs_run diag.s
```

Run a diag with debussy dump with default model

```
sims -sys=cmp -debussy -vcs_run diag.s <dump scope args>
```

Run a diag using arguments form specified alias in a diaglist

```
sims -vcs_run -sys=spc2 -group isa_mt -alias=isa_mmu_21:isa_mt isa_mmu_21.s
```

Run regressions

Run a regression using DV_ROOT as design root

```
sims -group=mini
```

Run a regression using DV_ROOT as design root and specify the diaglist

```
sims -group=mini -diaglist=/home/user/my_dialist
```

Run a regression using any design root

```
sims -group=mini -dv_root=/afara/design/regress/model/2002_06_03
```

Run a regression using any design root and a graft model

```
sims -group=mini -dv_root=/regress/model/2002_06_03  
-graft_flist=/home/regress/graftfile
```

Rerun a diag in a regression (in new rerun_x subdir)

```
sims -rerun
```

Rerun a diag, overwriting same directory

```
sims -rerun -overwrite
```

A.2 midas help

NAME

midas - assembles diags (Midas Is a Diag ASsembler)

SYNOPSIS

```
midas [options] <diag_name>
```

DESCRIPTION

This program builds assembly diags. It is substantially more involved than simply assembling the diag because it also has to link the diag, program the MMU, and generate several output files.

The diag specified on the command line will be built.

Pretty much everything else is configurable.

Options

The following are the options you need to get started:

-h Display man page.

-verbose [level] / -noverbose (abbreviated -v / -nov)
Sets verbosity level (default=2). -noverbose (or -nov) is a synonym for -verbose 0, which means to generate no output in the absence of errors. The highest level of verbosity currently defined is 3.

-version
Return version information and exit.

-format
Display help on the diag format and exit.

- config <file>
Use this file as the config file instead of the one that is distributed with Midas.
- project <project>
Use this project for project-specific configuration. Default is the environment variable \$PROJECT. Legal values are BW and N2.

Common Options

The following are the commonly-used options:

- diag_root <path>
Use the specified path as a base for finding standard include files. Default is \$DV_ROOT.
- build_dir <path>
Path (absolute or relative to where command is invoked) to directory where temporary files are generated and the build is done. Default is './build'.
- dest_dir <path>
Path (absolute or relative to where command is invoked) of where to store output files. Default is './'.
- find_root <dir>
Interpret the diag on the command-line as the name of a diag to search for. It does a breadth-first search under the specified directory. The default behavior is not to do any search, but to assume that the specified diag is a full or relative path to the file.
- find
This is a shortcut for "-find_root <diag_root>/verif/diag".
- mmu <mmu_type>
Generate programming for the specified MMU. Recognized options are "ultra2", "niagara", and "niagara2". Default is project-specific: "niagara" for Niagara-1 and "niagara2" for Niagara-2.
- tdefmt <tte_format>
Specifies TTE format for those MMUs that require it. May be "sun4u" or "sun4v". Default is project-specific: "sun4v" for Niagara-1 and Niagara-2.

- `-tsbtagfmt <tsbtagfmt>`
Specifies the format of the TSB tag. Legal values are 'tagaccess' and 'tagtarget'. Default is project-specific: 'tagaccess' for Niagara-1 and 'tagtarget' for Niagara-2.
- `-force_build` or `-f`
Build the diag, even if it looks like we have the same input as before and the same args as before.
- `-copy_products` / `-nocopy_products`
By default, the product files generated in the build directory are hard-linked to the destination directory. The reason they are hard-linked and not copied is for speed. If the hard link fails, it will fall back to a copy in case the directories are on different physical disks. If `-copy_products` is given, however, it will always do a copy, not a hard link. Default is project-specific: `-nocopy_products` for Niagara-1.
- `-E` Stop after the preprocessing stage.
- `-addphdr` / `-noaddphdr`
If `-addphdr` is enabled and the project env variable is N2, Midas will add PHDR commands into the `diag.ld_scr` (linker script file). This option is currently by default disabled. N2 needs this option to optimize the size of the `diag.exe` file.
- `-cleanup` / `-nocleanup`
If `-cleanup` is enabled, then after a successful build, the build directory is erased if and only if the build directory was created by this invocation of midas. Default is project-specific: `-cleanup` for Niagara-1.
- `-force_cleanup` / `-noforce_cleanup`
If `-cleanup` is enabled, but this invocation of midas did not create the build directory, `-force_cleanup` will remove the build directory anyway. Default is project-specific: `-noforce_cleanup` for Niagara-1.
- `-D<symbol>` or `-D<symbol>=<value>`
Add a define to the preprocessing line. Option may be repeated.
- `-stddef` / `-nostddef`
Include standard preprocessor definitions on command-line. `-nostddef` disables these. Default is `-stddef`, but no standard symbols are currently defined.

`-I<dir>`
 Add a directory to the include path used by `cpp` and `m4`. Path should be absolute or relative to the directory where `midas` was invoked. Option may be repeated.

`-stdinc / -nostdinc`
 With `-stdinc`, the standard include paths are used during preprocessing (both `cpp` and `m4`). `-nostdinc` disables these. Default is `-stdinc`. The standard include directories are the directory where `midas` was invoked, the build directory and `<diag_root>/verif/diag/assembly/include` (keep in mind that `<diag_root>` defaults to `$DV_ROOT`).

`-include_build / -noinclude_build`
 This option is only meaningful with `-nostdinc`. If standard includes are switched off, `-include_build` will add the build directory back to the include path. Default is `-noinclude_build`.

`-include_start / -noinclude_start`
 This option is only meaningful with `-nostdinc`. If standard includes are switched off, `-include_start` will add the start directory (the directory where `midas` was invoked) back to the include path. Default is `-noinclude_start`.

`-L<dir>`
 Add a directory to the search path when looking for object files in a `MIDAS_OBJ` directive. Option may be repeated.

`-C<dir>`
 Add a directory to the search path when looking for C source files in a `MIDAS_CC` directive. Option may be repeated.

`-pal_diag_args <args>`
 If the `diag` is run through `pal`, give these arguments to the `pal diag`. Option may be repeated. Note that these arguments are given to the `diag`, not `pal` itself. For instance, `"midas -pal_args -abc mydiag.pal -pal_diag_args def -pal_diag_args ghi"` will run the `pal` command-line `"pal -abc mydiag.pal def ghi"`.

`-build_threads <num_threads>`
 When doing work that can be done in parallel (such as assembling a bunch of files), use `<num_threads>` to do

it. Default is project-specific: 3 for Niagara-1.

`-print_errors / -noprnt_errors`
 If `-noprnt_errors` is defined, then generation of error messages is turned off. When used with `-verbose 0`, midas is completely silent. This is probalby only useful for the test harness (which is why the switch is there).

`-copy_products / -nocopy_products`
 If this is set, then copy files from the build directory to the starting directory. With `-nocopy_products`, the files are hard linked instead. If it tries to create a hard link and fails, it will fall back to a copy. Default is `-nocopy_products`.

`-compress_image / -nocompress_image`
 If `-compress_image` is enabled (as it is by default), then allow compressed mem.images to be generated. By default, all MMU-generated blocks are compressed when written to mem.image, meaning that instead of initializing unused sections to zero, they are simply uninitialized. The `-nocompress_image` is equivalent to explicitly putting a `'compressimage=0'` in all `attr_text/attr_data` blocks.

`-env_zero / -noenv_zero`
 When compressing blocks, if `-env_zero` is enabled the blocks will contain `'// zero_image'` directives to the environment. These directives are supported only by Niagara, and they are used to backdoor initialize large tracts of memory to zero. If `-noenv_zero` is used, then compression will simply leave the data uninitialized.

`-default_radix <decimal|hex>`
 Radix to assume for all parameters that do not explicitly start with `'0x'`. Default is `'decimal'`.

`-gen_all_tsbs / -nogen_all_tsbs`
 If `-gen_all_tsbs` is given, then all TSBs that are defined are written to the memory image. If `-nogen_all_tsbs`, then generate only the TSBs that are used. Default is project-specific: `-nogen_all_tsbs` for Niagara-1.

`-allow_tsb_conflicts / -noallow_tsb_conflicts`
 If `-allow_tsb_conflicts` is enabled, then it is legal to have mutiple virtual address map to the same entry in a TSB. A linked-list will be created to hold all entries. With `-noallow_tsb_conflicts` (which is the default for

N1), collisions in the TSB can only happen with the save VA but different contexts. Default is project-specific.

- `-allow_empty_sections / -noallow_empty_sections`
If `TEXT_VA` is specified, then at least one `attr_text` block for the section has to be specified, and the same is true for `DATA_VA` and `attr_data` blocks. If `-allow_empty_sections` is specified, then midas will allow you to specify a `TEXT_VA(DATA_VA)` for the section, even if the section has no `attr_text(attr_data)` blocks. Of course, any text(data) in such a section will be ignored. Default is project-specific:
`-noallow_empty_sections` for Niagara-1.
- `-allow_duplicate_tags / -noallow_duplicate_tags`
When adding to a TSB link list, it is an error to add the same tag twice. `-allow_duplicate_tags` suspends the error check. Default is project-specific:
`-noallow_duplicate_tags` for Niagara-1.
- `-allow_illegal_page_sizes / -noallow_illegal_page_sizes`
If `-allow_illegal_page_sizes`, then `tte_size` attributes are not checked for valid values, though they are still checked against the width of the field. For instance, in the Niagara MMU, there are 3 page bits, so values can be specified 0-7. However, the only legal values for Niagara are 0, 1, 3, and 5, and unless `-allow_illegal_page_sizes` is in effect, setting page bits of 2, 4, 6, or 7 will cause an error. The default is project-specific: `-noallow_illegal_page_sizes` for Niagara-1.
- `-allow_misaligned_tsb_base / -noallow_misaligned_tsb_base`
If `-allow_misaligned_tsb_base` is set, then a TSB base address need not be aligned with the TSB size. Real software will never do this, but I want it to be possible in diags. If an unaligned address is specified as the base and `-allow_misaligned_tsb_base` is specified, then midas will forcibly align the address. Default should be `-noallow_misaligned_tsb_base` for all projects.
- `-errcode <error_code>`
Prints a one-line description for the midas error code. Then exits with status 0.

Configuring Commands

midas runs several commands in the course of its operation.

Several of these can be configured. The configurable commands are: `pal`, `cpp`, `m4`, `gcc`, `as`, and `ld`. Each configurable command has 3 associated options:

`-std_<command>_args / -nostd_<command>_args`
When `-std_<command>_args` is enabled, the standard set of arguments for `<command>` are used. Default is `-std_<command>_args`

`-<command>_args <args>`
Add `<args>` to the argument list for the specified `<command>`.

`-<command>_cmd <custom_command>`
Use `<custom_command>` to run the specified `<command>` instead of the standard version.

Example

For instance, to add `-foo` to the link line, use `my_cpp` to preprocess, and not use any standard assembler options, use:

```
midas -ld_args -foo -cpp_cmd my_cpp -nostd_as_args mydiag.s
```

Configuring Filenames

There are several generated files, and they all have default names. You can configure the names of many of the files with the following option.

`-file <tag>=<name>`
Cause midas to name the file whose tag is `<tag>` to be named `<name>` instead of the default. `<name>` is treated as the name of a file in the build directory.

The list of valid tags for the `-file` option are:

`src` Local version of the original source code for the diag.
Default is `'diag.src'`.

`s` Assembly portion of diag before any preprocessing.
Default is `'diag.s'`.

`pl` Perl portion of the diag. Default is `'diag.pl'`.

`cpp` Output of the C preprocessor. Default is `'diag.cpp'`.

`m4` Output of the m4 preprocessor. Default is `'diag.m4'`.

ldscr
Linker script. Default is 'diag.ls_scr'.

exe Linked executable. Default is 'diag*.exe' where * is application name.

image
Verilog memory image. Default is 'mem.image'.

events
Events file. Default is 'diag.ev'.

syntab
Symbol table. Default is 'symbol.tbl'.

goldfinger
Specification to goldfinger on how to create memory image. Default is 'diag.goldfinger'.

directives
File to contain midas directives after section splitting. Default is 'diag.midas'.

cmdfile
File to stash the midas command-line. Default is '.midas_args'.

oldcmdfile
File to move old command-line options. Default is '.midas_args.old'.

oldm4
File to stash m4 output of previous run. Default is '.midas.diag.m4.old'.

Running Specific Phases

The build process is broken into phases: setup, preprocess, sectioning, assemble, link, postprocess, copydest, cleanup. The default behavior is to run all phases. You can, however, restrict operation to a selected set of phases.

-start_phase <phase_name>
Start with the named phase and run all subsequent phase.

-phase <phase_name>
Run the specified phase. If any -phase or -start_phase option exists, then by default all phases are off

(except for the ones that `-phase` and `-start_phase` switch on). You can have multiple `-phase` options.

`-E` This option (mentioned above, which runs the preprocessor only) is just a shortcut for `"-phase setup -phase preprocess"`.

Keep in mind that running selected phases is caveat emptor. There are cases where phases expect data or files from previous phases. You may get lucky, but don't blame me if it doesn't work.

Errors

When midas is unable to run correctly it will exit with one of the following error codes.

`M_NOERROR` (#0): No error.
`M_MISC` (#1): Miscellaneous error
`M_CODE` (#2): Error in midas code.
`M_DIR` (#3): Directory error.
`M_FILE` (#4): File error.
`M_CMDFAIL` (#5): Command failed.
`M_SECSYNTAX` (#6): Error in section syntax.
`M_ATTRSYNTAX` (#7): Error in attr syntax.
`M_MISSINGPARAM` (#8): Missing parameter.
`M_ILLEGALPARAM` (#9): Illegal parameter.
`M_OUTOFRANGE` (#10): Out of range.
`M_NOTNUM` (#11): Not a number.
`M_VACOLLIDE` (#12): VA collision.
`M_PACOLLIDE` (#13): PA collision.
`M_DIRECTIVESYNTAX` (#14): Directive syntax error.
`M_GENFAIL` (#15): File generation failed.
`M_ASMFAIL` (#16): Assembler failed.
`M_CCFAIL` (#17): C compiler failed.
`M_LINKFAIL` (#18): Linker failed.
`M_CPPFAIL` (#19): CPP failed.
`M_M4FAIL` (#20): M4 preprocessor failed.
`M_BADCONFIG` (#21): Bad configuration.
`M_EVENTERR` (#22): Event parsing error.
`M_ARGERR` (#23): Argument error.
`M_NOSEC` (#24): Undefined section.
`M_BADTSB` (#25): Bad TSB.
`M_BADALIGN` (#26): Bad Alignment.
`M_EMPTYSECTION` (#27): Empty section.
`M_TSBSYNTAX` (#28): Error in tsb syntax.
`M_APPSNTAX` (#29): Error in app syntax.'
`M_MEMORY` (#30): Memory error.
`M_GOLDFINGERPARSE` (#31): Goldfinger parse error.

M_GOLDFINGERARG (#32): Goldfinger arg error.
M_ELF (#33): ELF error.
M_BADLABEL (#34): Bad label.
M_GOLDFINGERMISC (#35): Uncategorized goldfinger error.
M_GOLDFINGERVERSION (#36): Bad version of goldfinger
M_DUPLICATETAG (#37): Duplicate tags in TSB
M_BLOCKSyntax (#38): Error defining goldfinger BLOCK

A.3 regreport

DESCRIPTION

regreport examines all regression *.log files for diags under regression directory and prints report. It is called by sims for each diag. User typically calls regreport to generate summary of regression.

Usage: regreport <options> [<directory> [<list>]]

OPTIONS

- l [<regress_dir>]:
print report for the specified or current-directory diag; [regress dir].
- regress <output_file> <directory>:
in regression mode, regreport writes summary status for finished diags to a file until all diags are finished. NOTE: if some diag does not produce status, regreport,1.64.2 will wait forever.
- ver
print version number and exit.
- sas_only
vcs.log will not be scanned, sas.log only.
- [no]cut_name
cuts the name from a sss:sss:sss:ddd formatted name. Default is to cut.
- regenerate
will regenerate the status.log files in the diag directories.
- clean_pass
will clean up passing directories.
- fails_only
will show details for fails only

<directory> [<list>]
print report for all diags under <directory>. <list> is
0 or more of simulation 'system' names, such as
'spc2', 'cmp', 'cml', 'cmp8', etc. When nothing
specified, all systems are included.

ENVIRONMENT VARIABLES:

CLEAN_PASS : Clean passing dirs
REGRESS_MAIL : Set to comma seperated list. Default is to send user
email when run in regress mode. When set to "no"
sends no email at all.
REGREPORT_FAILS_ONLY : Show details for fails only.