



6-A OUTPUT ACTIVE BUS TERMINATION SYNCHRONOUS PWM SWITCHER WITH INTEGRATED FETs (SWIFT™)

FEATURES

- Tracks Externally Applied Reference Voltage
- 30-mΩ, 12-A Peak MOSFET Switches for High Efficiency at 6-A Continuous Output Source or Sink Current
- 6% to 90% VIN Output Tracking Range
- PWM Frequency Range:
Fixed 350 kHz or Adjustable 280 to 700 kHz
- Load Protected by Peak Current Limit and Thermal Shutdown
- Integrated Solution Reduces Board Area and Component Count

APPLICATIONS

- DDR Memory Termination Voltage
- Active Termination of GTL and STL High-Speed Logic Families
- DAC Controlled High Current Output Stage
- Precision Point of Load Power Supply

DESCRIPTION

As a member of the SWIFT™ family of dc/dc regulators, the TPS54672 active bus termination synchronous PWM converter integrates all required active components. Included on the substrate with the listed features are a true, high performance, voltage error amplifier that enables maximum performance and flexibility in choosing the output filter L and C components; an under-voltage-lockout circuit to prevent start-up until the input voltage reaches 3 V; a slow-start control to limit in-rush currents; and a status output to indicate valid operating conditions.

The TPS54672 is available in a thermally enhanced 28-pin TSSOP (PWP) PowerPAD™ package, which eliminates bulky heatsinks. TI provides evaluation modules and the SWIFT™ designer software tool to aid in quickly achieving high-performance power supply designs to meet aggressive equipment development cycles.

SIMPLIFIED SCHEMATIC

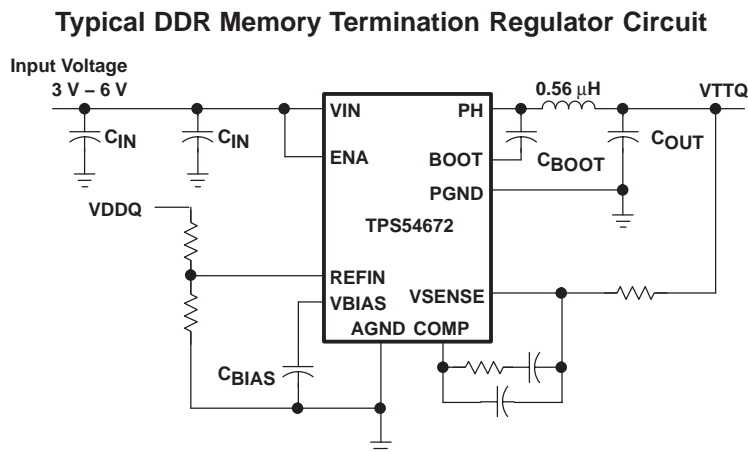

LOAD TRANSIENT RESPONSE

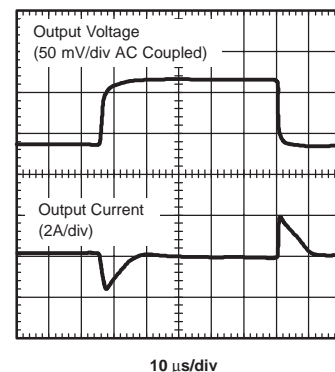

Please be aware that an important notice concerning availability, standard warranty, and use in critical applications of Texas Instruments semiconductor products and disclaimers thereto appears at the end of this data sheet.

PowerPAD and SWIFT are trademarks of Texas Instruments.

TPS54672

SLVS397C – JULY 2001 – REVISED FEBRUARY 2005



These devices have limited built-in ESD protection. The leads should be shorted together or the device placed in conductive foam during storage or handling to prevent electrostatic damage to the MOS gates.

ORDERING INFORMATION

T _A	REFIN VOLTAGE	PACKAGE	PART NUMBER
–40°C to 85°C	0.2 V to 1.75 V	Plastic HTSSOP (PWP) ⁽¹⁾	TPS54672PWP

(1) The PWP package is also available taped and reeled. Add an R suffix to the device type (i.e., TPS54672PWPR). See the application section of the data sheet for PowerPAD™ drawing and layout information.

(2) For the most current package and ordering information, see the Package Option Addendum at the end of this document, or see the TI website at www.ti.com.

ABSOLUTE MAXIMUM RATINGS

over operating free-air temperature range unless otherwise noted⁽¹⁾

		TPS54672
Input voltage range, V _I	VIN, ENA	–0.3 V to 7 V
	RT	–0.3 V to 6 V
	VSENSE, REFIN	–0.3 V to 4 V
	BOOT	–0.3 V to 17 V
Output voltage range, V _O	VBIAS, COMP, STATUS	–0.3 V to 7 V
	PH	–0.3 V to 10 V
Source current, I _O	PH	Internally Limited
	COMP, VBIAS	6 mA
Sink current, I _S	PH	12 A
	COMP	6 mA
	STATUS	10 mA
Voltage differential, AGND to PGND		±0.6 V
Operating virtual junction temperature range, T _J		–40°C to 125°C
Storage temperature, T _{stg}		–65°C to 150°C
Lead temperature 1,6 mm (1/16 inch) from case for 10 seconds		300°C

(1) Stresses beyond those listed under “absolute maximum ratings” may cause permanent damage to the device. These are stress ratings only, and functional operation of the device at these or any other conditions beyond those indicated under “recommended operating conditions” is not implied. Exposure to absolute-maximum-rated conditions for extended periods may affect device reliability.

DISSIPATION RATINGS⁽¹⁾⁽²⁾

PACKAGE	THERMAL IMPEDANCE JUNCTION-TO-AMBIENT	T _A = 25°C POWER RATING	T _A = 70°C POWER RATING	T _A = 85°C POWER RATING
28 Pin PWP with solder	18.2 °C/W	5.49 W ⁽³⁾	3.02 W	2.20 W
28 Pin PWP without solder	40.5 °C/W	2.48 W	1.36 W	0.99 W

(1) For more information on the PWP package, refer to TI technical brief, literature number SLMA002.

(2) Test board conditions:

- 3" x 3", 4 layers, thickness: 0.062"
- 1.5 oz. copper traces located on the top of the PCB
- 1.5 oz. copper ground plane on the bottom of the PCB
- 0.5 oz. copper ground planes on the 2 internal layers
- 12 thermal vias (see “Recommended Land Pattern” in applications section of this data sheet)

(3) Maximum power dissipation may be limited by over current protection.

ADDITIONAL 6A SWIFT™ DEVICES, (REFER TO SLVS398 AND SLVS400)

DEVICE	OUTPUT VOLTAGE	DEVICE	OUTPUT VOLTAGE	DEVICE	OUTPUT VOLTAGE
TPS54611	0.9 V	TPS54614	1.8 V	TPS54610	Adjustable
TPS54612	1.2 V	TPS54615	2.5 V	TPS54673	Disabled sink during startup
TPS54613	1.5 V	TPS54616	3.3 V	TPS54680	Sequencing

ELECTRICAL CHARACTERISTICS
 $T_J = -40^{\circ}\text{C}$ to $+125^{\circ}\text{C}$, $V_I = 3\text{ V}$ to 6 V over operating free-air temperature range (unless otherwise noted)

PARAMETER		TEST CONDITIONS	MIN	TYP	MAX	UNIT
SUPPLY VOLTAGE, VIN						
	Input voltage range, VIN		3.0		6.0	V
V _{ID}	Differential voltage, AGND to PGND		-0.30		0.30	V
I _(Q)	Quiescent current	Switching freq. = 350 kHz, RT open		10	16	mA
		Switching freq. = 500 kHz, RT = 100 k Ω		16	24	
		Shutdown, SS/ENA = 0 V		1	1.4	
UNDERVOLTAGE LOCKOUT						
	Start threshold voltage, UVLO			2.95	3.00	V
	Stop threshold voltage, UVLO		2.70	2.80		V
	Hysteresis voltage, UVLO		0.14	0.16		V
	Rising and falling edge deglitch, UVLO ⁽¹⁾			2.5		μs
BIAS VOLTAGE						
	Output voltage, VBIAS	I _(VBIAS) = 0	2.70	2.80	2.90	V
	Output current, VBIAS ⁽²⁾				100	μA
CUMULATIVE REFERENCE						
	Cumulative regulation accuracy (relative to REFIN)	I _O = -6A to 6A, Switching frequency = 350 kHz, REFIN = 1.25 V ⁽¹⁾	-1.5%		1.5%	
OSCILLATOR						
	Internally set—free running frequency	RT open	280	350	420	kHz
	Externally set—free running frequency range	RT = 68 k Ω to 180 k Ω	280		700	kHz
	Externally set—free running frequency accuracy	RT = 100 k Ω (1% resistor to AGND)	460	500	540	kHz
	Ramp valley			0.75		V
	Ramp amplitude (peak-to-peak)			1		V
	Minimum controllable on time ⁽¹⁾				200	ns
	Maximum duty cycle ⁽¹⁾		90%			
	Error amplifier open loop voltage gain	1 k Ω COMP to AGND ⁽¹⁾	90	110		dB
	Error amplifier unity gain bandwidth	Parallel 10 k Ω , 160 pF COMP to AGND ⁽¹⁾	3	5		MHz
	Error amplifier common mode input voltage range ⁽¹⁾		0		2.85	V
	Error amplifier common mode rejection ratio ⁽¹⁾			65		dB
	Input bias current, VSENSE	VSENSE = REFIN = 1 V		60	250	nA
	Input bias current, REFIN	VSENSE = REFIN = 1.25 V		60	250	nA
	Input offset voltage, REFIN	VSENSE = REFIN = 1.25 V	-1.5		1.5	mV
	Input voltage range, REFIN ⁽¹⁾		0		1.8	V
	Output voltage slew rate (symmetric), COMP		1	1.4		V/ μs
	Common mode output voltage range, COMP	I _O = 3 mA			2.65	V
		I _O = -3 mA	0.2			
	PWM comparator propagation delay time, PWM comparator input to PH pin (excluding deadtime)	10-mV overdrive ⁽¹⁾		70	85	ns
	Enable threshold voltage, ENA		0.82	1.20	1.40	V
	Enable hysteresis voltage, ENA ⁽¹⁾			0.03		V
	Falling edge deglitch, ENA ⁽¹⁾			2.5		μs
	Leakage current, ENA	V _I = 5.5 V			1	μA

⁽¹⁾ Ensured by design

⁽²⁾ Static resistive loads only

TPS54672

SLVS397C – JULY 2001 – REVISED FEBRUARY 2005

ELECTRICAL CHARACTERISTICS Continued

 $T_J = -40^{\circ}\text{C}$ to $+125^{\circ}\text{C}$, $V_I = 3\text{ V}$ to 6 V over operating free-air temperature range (unless otherwise noted)

PARAMETER	TEST CONDITIONS	MIN	TYP	MAX	UNIT
OSCILLATOR (CONTINUED)					
Output saturation voltage, STATUS	$I_{(\text{sink})} = 2.5\text{ mA}$		0.18	0.3	V
Leakage current, STATUS	$V_I = 5.5\text{ V}$			1	μA
Current limit trip point	$V_{IN} = 3\text{ V}$ (1)	7	10		A
	$V_{IN} = 6\text{ V}$ (1)	10	12		
Current limit leading edge blanking time			100		ns
Current limit total response time			200		ns
Thermal shutdown trip point (1)		135	150	165	$^{\circ}\text{C}$
Thermal shutdown hysteresis (1)			10		$^{\circ}\text{C}$
$r_{DS(\text{on})}$ Low/high-side N-MOSFET	$I_O = 6\text{ A}$, $V_I = 3\text{ V}$ (3)		36	65	$\text{m}\Omega$
	$I_O = 6\text{ A}$, $V_I = 6\text{ V}$ (3)		26	47	

(1) Ensured by design

(2) Static resistive loads only

 (3) Matched MOSFETs, low side $r_{DS(\text{on})}$ production tested, high side $r_{DS(\text{on})}$ ensured by design

PIN ASSIGNMENTS

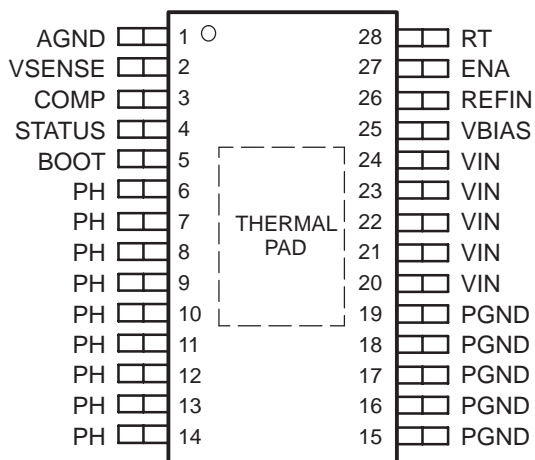
**PWP PACKAGE
(TOP VIEW)**

TERMINAL FUNCTIONS

TERMINAL NAME NO.		DESCRIPTION
AGND	1	Analog ground. Return for compensation network/output divider, VBIAS capacitor, and RT resistor. Connect PowerPAD to AGND.
BOOT	5	Bootstrap output. 0.022 μ F to 0.1 μ F low-ESR capacitor connected from BOOT to PH generates floating drive for the high-side FET driver.
COMP	3	Error amplifier output. Connect frequency compensation network from COMP to VSENSE
ENA	27	Enable input. Logic high enables oscillator, PWM control and MOSFET driver circuits. Logic low disables operation and places device in low quiescent current state.
PGND	15–19	Power ground. High current return for the low-side driver and power MOSFET. Connect PGND with large copper areas to the input and output supply returns, and negative terminals of the input and output capacitors. A single point connection to AGND is recommended.
PH	6–14	Phase output. Junction of the internal high-side and low-side power MOSFETs, and output inductor.
REFIN	26	External reference input. High impedance input to slow-start and error amplifier circuits.
RT	28	Frequency setting resistor input. Connect a resistor from RT to AGND to set the switching frequency.
STATUS	4	Open drain output. Asserted low when $V_{IN} < UVLO$ threshold, VBIAS and internal reference are not settled or thermal shutdown active. Otherwise STATUS is high.
VBIAS	25	Internal bias regulator output. Supplies regulated voltage to internal circuitry. Bypass VBIAS pin to AGND pin with a high-quality, low-ESR 0.1- μ F to 1.0- μ F ceramic capacitor.
VIN	20–24	Input supply for the power MOSFET switches and internal bias regulator. Bypass VIN pins to PGND pins close to device package with a high-quality, low-ESR 10- μ F ceramic capacitor.
VSENSE	2	Error amplifier inverting input. Connect to output voltage through compensation network/output divider.

TPS54672

SLVS397C – JULY 2001 – REVISED FEBRUARY 2005

INTERNAL BLOCK DIAGRAM

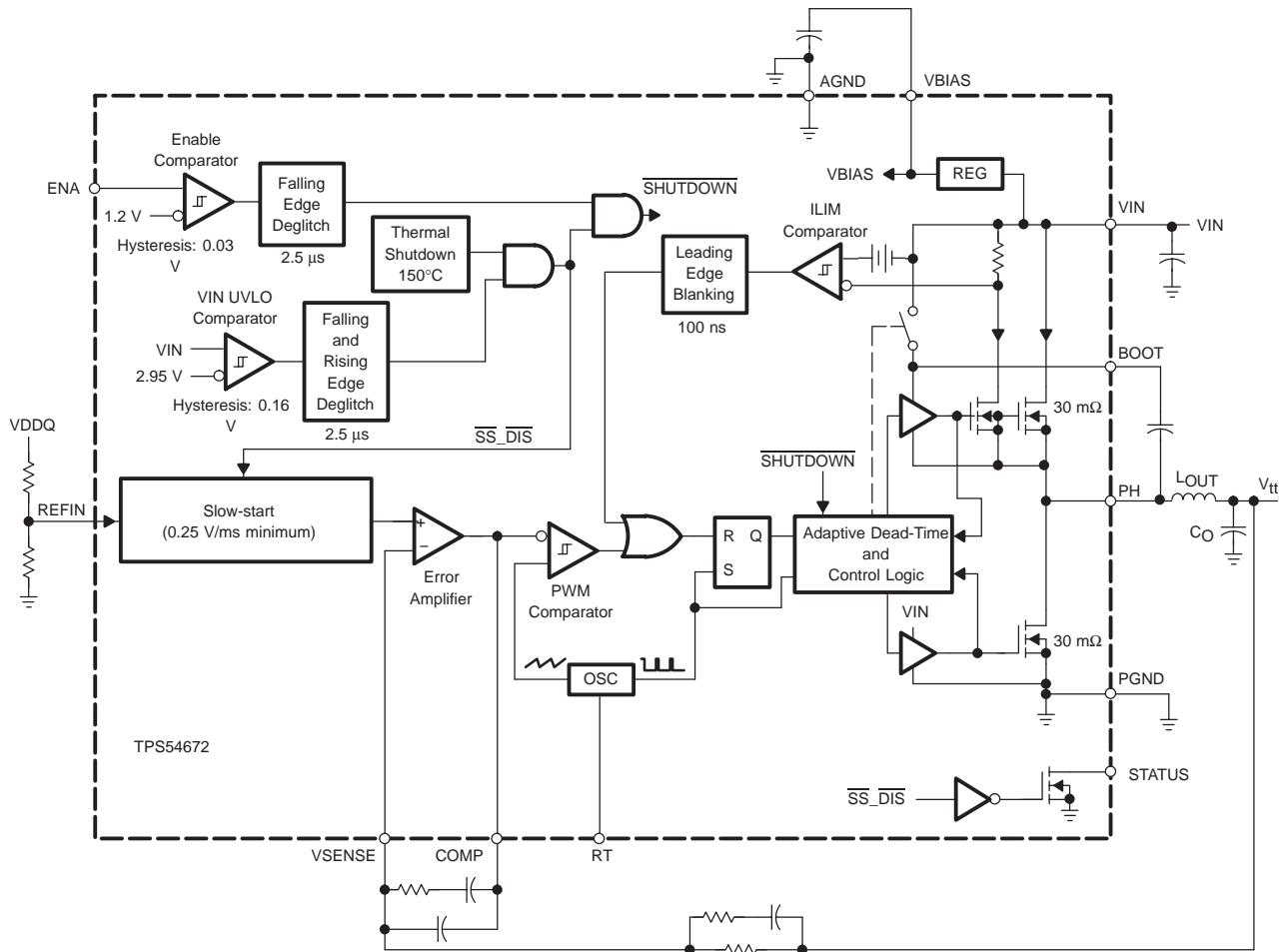

RELATED DC/DC PRODUCTS

- TPS54372
- TPS54972
- TPS54872

TYPICAL CHARACTERISTICS

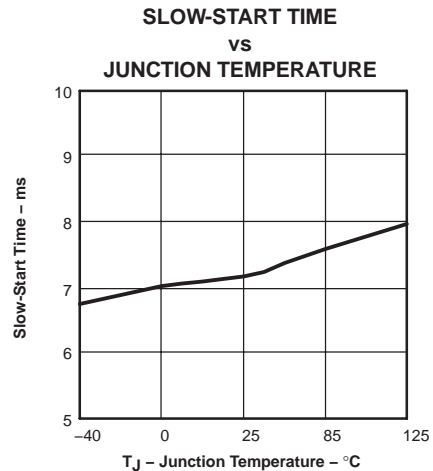
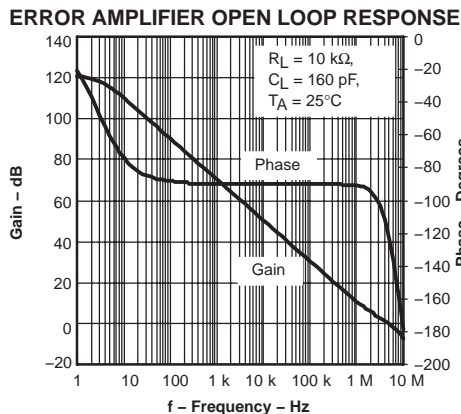
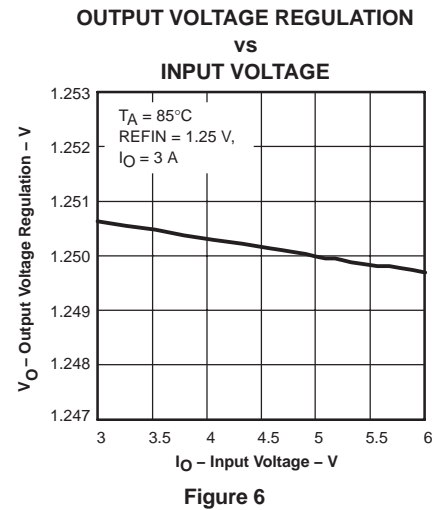
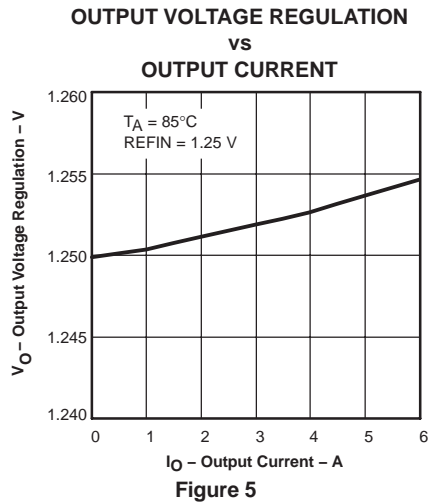
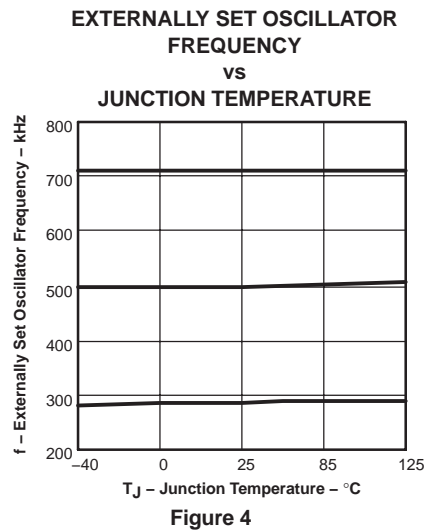
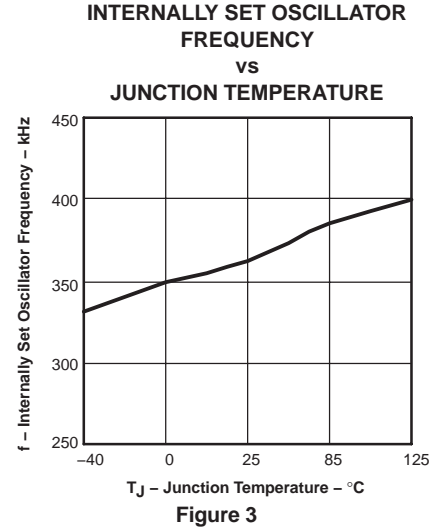
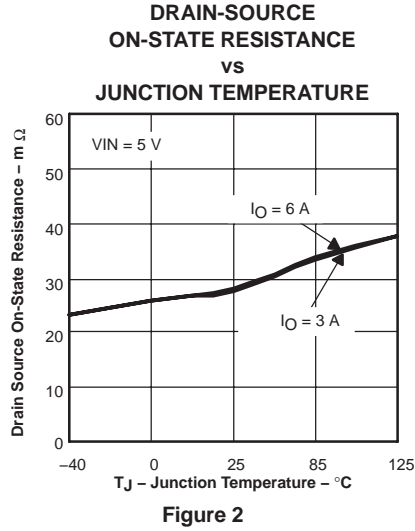
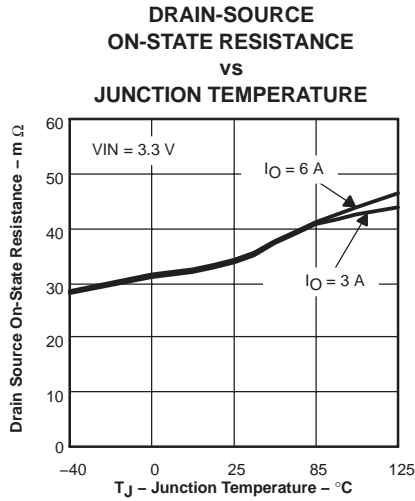

APPLICATION INFORMATION

Figure 9 shows the schematic diagram for a typical DDR memory or GTL bus termination application using the TPS54672. The TPS54672 (U1) can provide greater than 6 A of output current. For proper operation, the exposed thermal PowerPAD underneath the integrated circuit package needs to be soldered to the printed-circuit board.

COMPONENT SELECTION

The values for the components used in this design example were selected for best load transient and tracking response. Additional design information is available at www.ti.com.

INPUT VOLTAGE

The input voltage range is 3 to 5.5 VDC. The input filter (C4) is a 10- μ F ceramic capacitor (Taiyo Yuden). C8, also a 10- μ F ceramic capacitor (Taiyo Yuden) that provides high frequency decoupling of the TPS54672 from the input supply, must be located as close as possible to the device. Ripple current is carried in both C8 and C4, and the return path to PGND should avoid the current circulating in the output capacitors C7 and C10.

FEEDBACK CIRCUIT

R1, R2, R3, C1, C2 and C3 form the loop compensation network for the circuit. For this design, a Type 3 topology is used. The compensation network, along with the output filter inductor and capacitor delivers a crossover frequency of 135 kHz with 50° of phase margin.

OPERATING FREQUENCY

In the application circuit, RT is grounded through a 71.5-k Ω resistor to select the maximum frequency of 700 kHz. To set a different frequency, place a 68-k Ω to 180-k Ω resistor between RT (pin 28) and analog ground or leave RT floating to select the default 350 kHz. The resistance can be calculated using the following equation:

$$R = \frac{500 \text{ kHz}}{\text{SwitchingFrequency}} \times 100 \text{ [k}\Omega\text{]} \quad (1)$$

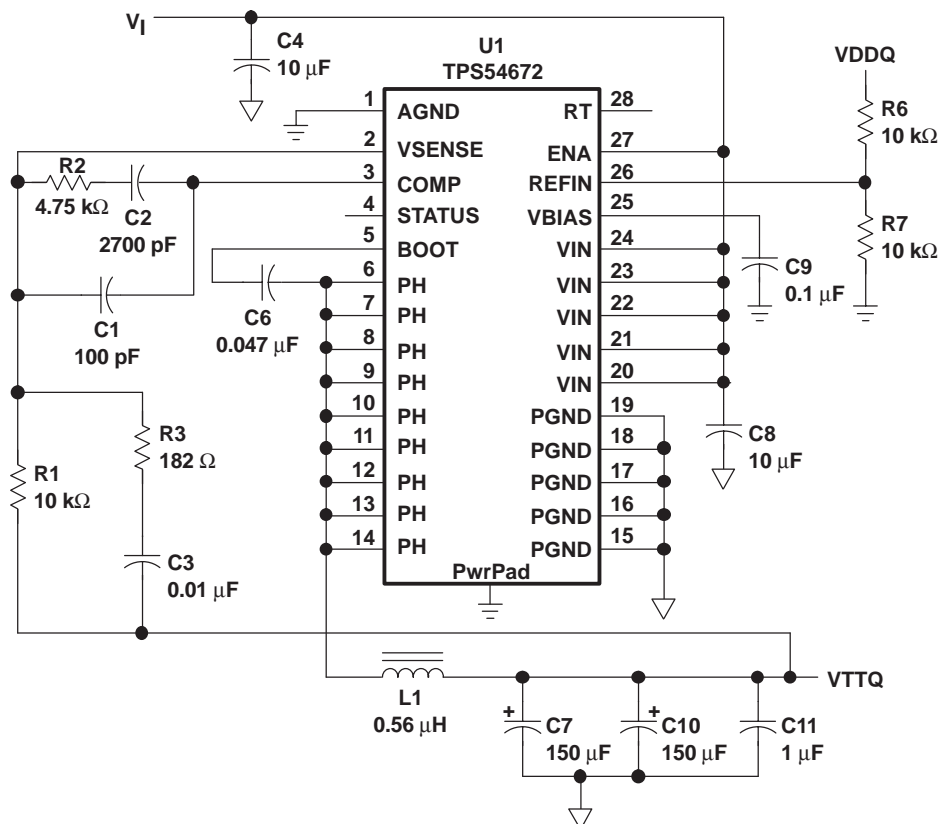

Figure 9. Application Circuit Optimized For Size And Performance

OUTPUT FILTER

The output filter is composed of a 0.56- μ H Coilcraft inductor (D01813P-561HC) and two 150- μ F Cornell Dublier capacitors (ESRD151M06R). The inductor is a low dc resistance type. The capacitors used are 4 V POSCAP types with a maximum ESR of 0.040 Ω .

PCB LAYOUT

Figure 10 shows a generalized PCB layout guide for the TPS54672. The VIN pins should be connected together on the printed circuit board (PCB) and bypassed with a low ESR ceramic bypass capacitor. Minimize the loop area formed by the bypass capacitor connections, the VIN pins, and the TPS54672 ground pins. The minimum recommended bypass capacitance is 10 μ F ceramic with a X5R or X7R dielectric and the optimum placement is closest to the VIN pins and the PGND pins.

The TPS54672 has two internal grounds (analog and power). Inside the TPS54672 the analog ground ties to all of the noise sensitive signals, while the power ground ties to the noisier power signals. Noise injected between the two grounds can degrade the performance of the TPS54672, particularly at higher output currents. Ground noise on an analog ground plane can also cause problems with some of the control and bias signals. For these reasons, separate analog and power ground traces are recommended. There should be an area of ground on the top layer under the IC, with an exposed area for connection to the PowerPAD. Use vias to connect this ground area to any internal ground planes. Use additional vias at the ground side of the input and output filter capacitors as well.

The AGND and PGND pins should be tied to the PCB ground by connecting them to the ground area under the device as shown. The only components that should tie directly to the power ground plane are the input capacitors, the output capacitors, the input voltage decoupling capacitor, and the PGND pins of the TPS54672. Use a separate wide trace for the analog ground signal path. This analog ground should be used for the voltage set point divider, timing resistor RT, and bias capacitor grounds. Connect this trace directly to AGND (pin 1).

The PH pins should be tied together and routed to the output inductor. Since the PH connection is the switching node, the inductor should be located very close to the PH pins and the area of the PCB conductor minimized to prevent excessive capacitive coupling.

Connect the boot capacitor between the phase node and the BOOT pin as shown. Keep the boot capacitor close to the IC and minimize the conductor trace lengths.

Connect the output filter capacitor(s) as shown between the VOUT trace and PGND. It is important to keep the loop formed by the PH pins, Lout, Cout, and PGND as small as practical.

Place the compensation components from the VOUT trace to the VSENSE, and COMP pins. Do not place these components too close to the PH trace. Due to the size of the IC package and the device pin out, the components must be routed somewhat close, however maintaining as much separation as possible while still keeping the layout compact.

Connect the bias capacitor from the VBIAS pin to analog ground using the isolated analog ground trace. If an RT resistor is used, connect it to this trace as well.

TPS54672

SLVS397C – JULY 2001 – REVISED FEBRUARY 2005

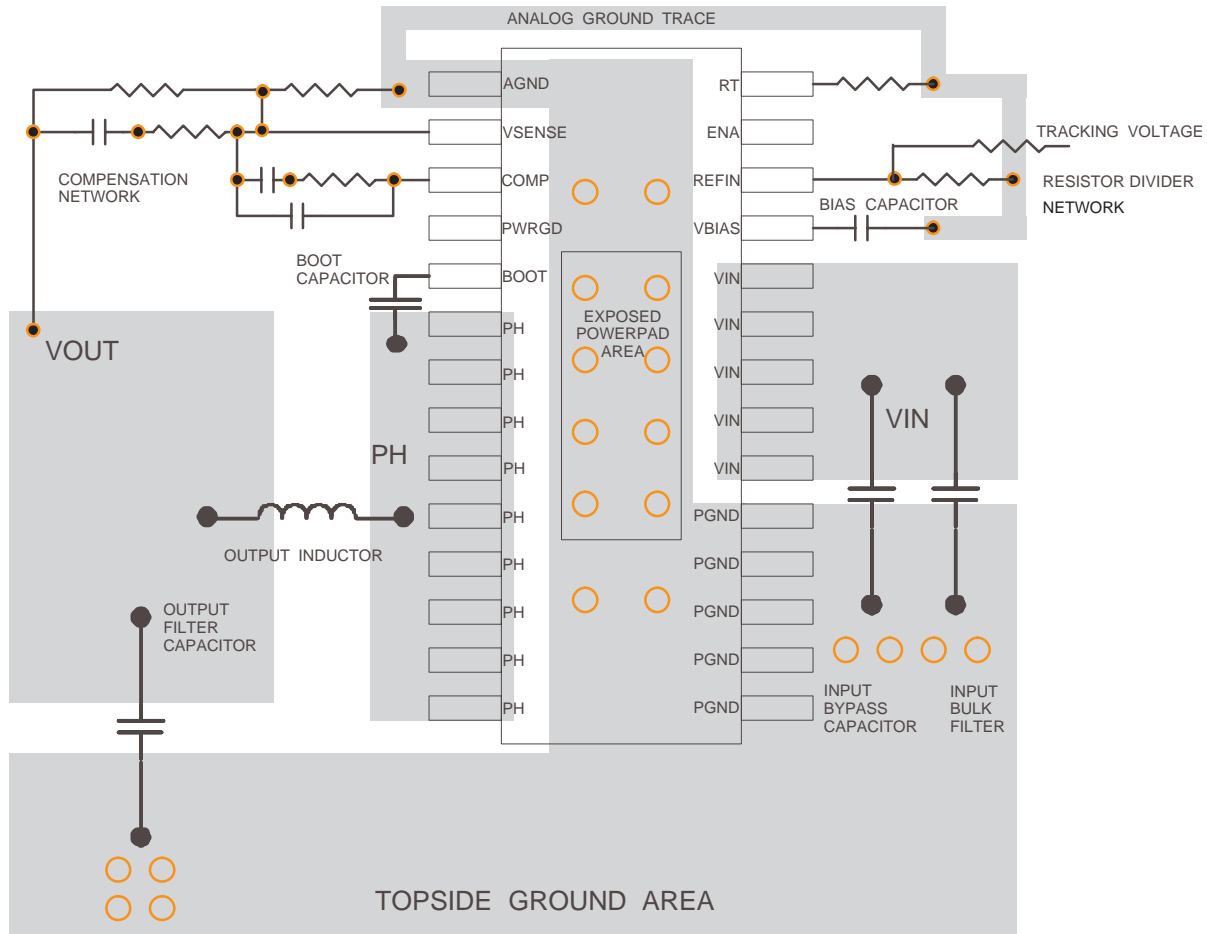

○ VIA to Ground Plane

Figure 10. TPS54672 PCB Layout

LAYOUT CONSIDERATIONS FOR THERMAL PERFORMANCE

For operation at full rated load current, the analog ground plane must provide adequate heat dissipating area. A 3 inch by 3 inch plane of 1 ounce copper is recommended, though not mandatory, depending on ambient temperature and airflow. Most applications have larger areas of internal ground plane available, and the PowerPAD should be connected to the largest area available. Additional areas on the top or bottom layers also help dissipate heat, and

any area available should be used when 6 A or greater operation is desired. Connection from the exposed area of the PowerPAD to the analog ground plane layer should be made using 0.013 inch diameter vias to avoid solder wicking through the vias. Eight vias should be in the PowerPAD area with four additional vias located under the device package. The size of the vias under the package, but not in the exposed thermal pad area, can be increased to 0.018. Additional vias beyond the twelve recommended that enhance thermal performance should be included in areas not under the device package.

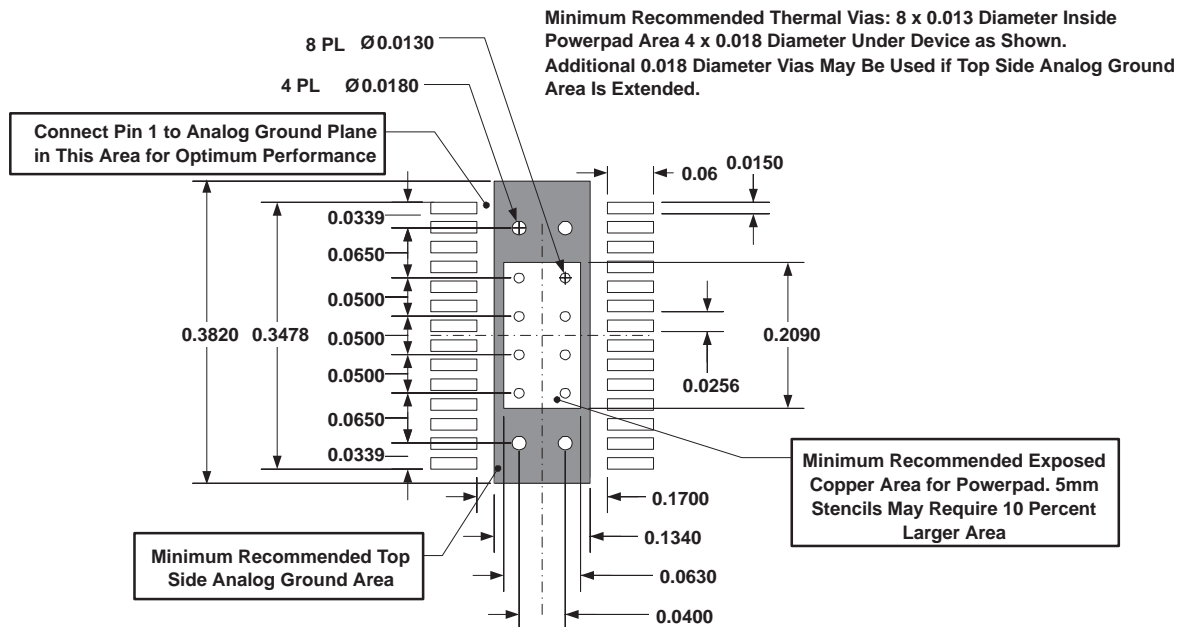

Figure 11. Recommended Land Pattern for 28-Pin PWP PowerPAD

LOAD TRANSIENT RESPONSE

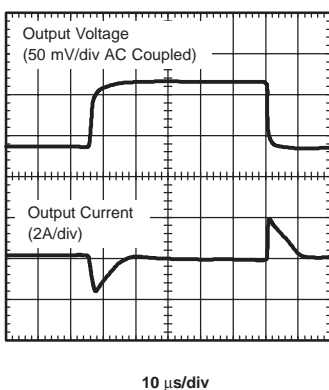

Figure 12

EFFICIENCY vs OUTPUT CURRENT

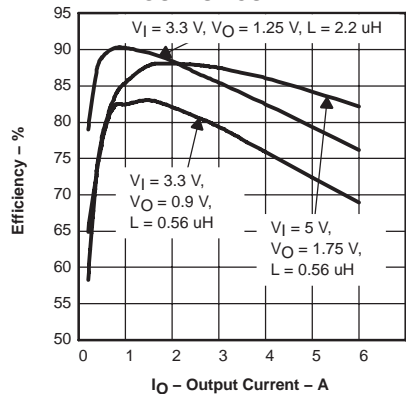

Figure 13

DETAILED DESCRIPTION

Under Voltage Lock Out (UVLO)

The TPS54672 incorporates an under voltage lockout circuit to keep the device disabled when the input voltage (V_{IN}) is insufficient. During power up, internal circuits are

held inactive until V_{IN} exceeds the nominal UVLO threshold voltage of 2.95 V. Once the UVLO start threshold is reached, device start-up begins. The device operates until V_{IN} falls below the nominal UVLO stop threshold of

TPS54672

SLVS397C – JULY 2001 – REVISED FEBRUARY 2005

2.8 V. Note that hysteresis in the UVLO comparator and a 2.5- μ s rising and falling edge deglitch circuit reduce the likelihood of shutting the device down due to noise on VIN.

Enable (ENA)

The enable pin, ENA, provides a digital control to enable or disable (shutdown) the TPS54672. An input voltage of 1.4 V or greater ensures that the TPS54672 is enabled. An input of 0.82 V or less ensures that device operation is disabled. These are not standard logic thresholds, even though they are compatible with TTL outputs.

When ENA is low, the oscillator, slow-start, PWM control and MOSFET drivers are disabled and held in an initial state ready for device start-up. On an ENA transition from low to high, device start-up begins with the output starting from 0 V.

Slow-Start

The slow-start circuit provides start-up slope control of the output voltage to limit in-rush currents. The nominal internal slow-start rate is 0.25 V/ms with the maximum rate being 0.35 V/ms. When the voltage on REFIN rises faster than the internal slope or is present when device operation is enabled, the output rises at the internal rate. If the reference voltage on REFIN rises more slowly, then the output rises at about the same rate as REFIN.

VBIAS Regulator (VBIAS)

The VBIAS regulator provides internal analog and digital blocks with a stable supply voltage over variations in junction temperature and input voltage. A high quality, low-ESR, ceramic bypass capacitor is required on the VBIAS pin. X7R or X5R grade dielectrics are recommended because their values are more stable over temperature. The bypass capacitor should be placed close to the VBIAS pin and returned to AGND.

External loading on VBIAS is allowed, with the caution that internal circuits require a minimum VBIAS of 2.7 V, and that loads with ac or digital switching noise may degrade performance. The VBIAS pin may be useful as a reference voltage for external circuits.

Oscillator Frequency (RT)

The oscillator frequency can be set to an internally fixed value of 350 kHz by leaving the RT pin unconnected (floating). If a different frequency of operation is required for the application, the oscillator frequency can be externally adjusted from 280 kHz to 700 kHz by connecting a resistor to the RT pin to ground. The operating frequency is approximated by the following equation, where R is the resistance from RT to AGND:

$$\text{Switching Frequency} = \frac{100 \text{ k}\Omega}{R} \times 500 \text{ [kHz]} \quad (2)$$

The following table summarizes the frequency selection configurations:

FREE RUNNING FREQUENCY	RT PIN
350 kHz, internally set	Float
Externally set 280 kHz to 700 kHz	R = 68 k to 180 k

Error Amplifier (REFIN, VSENSE, COMP)

The high performance voltage error amplifier, with wide 5MHz bandwidth, low 1.5 mV-max offset, 1.4 V/ μ s slew rate, and ground rail input range differentiates the TPS54672 from most dc/dc converters. The user is given the flexibility to use a wide range of output L and C filter components to suit the particular application needs. Type 2 or type 3 compensation can be employed using external compensation components.

The REFIN input range includes ground which allows 0% duty cycle during transient conditions. The user should note that steady state regulation accuracy of voltages less than 0.84 V is limited by the minimum controllable ON time.

PWM Control

Signals from the error amplifier output, oscillator and current limit circuit are processed by the PWM control logic. Referring to the internal block diagram, the control logic includes the PWM comparator, OR gate, PWM latch and portions of the adaptive dead time and control logic block. During steady state operation below the current limit threshold, the PWM comparator output and oscillator pulse train alternately reset and set the PWM latch. Once the PWM latch is set, the low-side FET remains on for a minimum duration set by the oscillator pulse width. During this period, the PWM ramp discharges rapidly to its valley voltage. When the ramp begins to charge back up, the low-side FET turns off and high-side FET turns on. As the PWM ramp voltage exceeds the error amplifier output voltage, the PWM comparator resets the latch, thus turning off the high-side FET and turning on the low-side FET. The low-side FET remains on until the next oscillator pulse discharges the PWM ramp.

During transient conditions, the error amplifier output could be below the PWM ramp valley voltage or above the PWM peak voltage. If the error amplifier is high, the PWM latch is never reset and the high-side FET remains on until the oscillator pulse signals the control logic to turn the high-side FET off and the low-side FET on. The device operates at its maximum duty cycle until the output voltage rises to the regulation set-point, setting VSENSE to approximately the same voltage as REFIN. If the error amplifier output is low, the PWM latch is continually reset and the high-side FET does not turn on. The low-side FET remains on until the VSENSE voltage decreases to a range that allows the PWM comparator to change states. The TPS54672 is capable of sinking current continuously until the output reaches the regulation set-point.

If the current limit comparator trips for longer than 100 ns, the PWM latch resets before the PWM ramp exceeds the error amplifier output. The high-side FET turns off and low-side FET on to decrease the output current. This process is repeated each cycle in which the current limit comparator is tripped.

Dead-Time Control and MOSFET Drivers

Adaptive dead-time control prevents shoot-through current from flowing in both N-channel power MOSFETs during the switching transitions by actively controlling the turnon times of the MOSFET drivers. The high-side driver does not turn on until the gate drive voltage to the low-side FET is below 2 V, while the low-side driver does not turn on until the voltage at the junction of the power MOSFETs (PH pin) is below 2 V.

The high-side and low-side drivers are designed with 300-mA source and sink capability to quickly drive the power MOSFETs gates. The low-side driver is supplied from VIN, while the high-side drive is supplied from the BOOT pin. A bootstrap circuit uses an external BOOT capacitor and internal 2.5- Ω bootstrap switch connected between the VIN and BOOT pins. The bootstrap switch is turned on when the low-side FET is on to charge the BOOT capacitor. The low resistance of the bootstrap switch improves drive efficiency and reduces external component count.

Overcurrent Protection

The cycle by cycle current limiting is achieved using a

sense-FET on the high-side MOSFET and differential amplifier with preset overcurrent threshold. The high-side MOSFET is turned off within 200 ns of the voltage on the sense-FET exceeding the current limit threshold. A 100-ns leading edge blanking circuit prevents false tripping of the current limit when the high-side switch is turning on. Current limit detection occurs only when current flows from VIN to PH when current is being sourced to the output filter. Load protection during current sink operation is provided by thermal shutdown.

Thermal Shutdown

Thermal shutdown turns off the power MOSFETs and disables the control circuits if the junction temperature exceeds the 150°C. The device is released from shutdown automatically when the junction temperature decreases to 10°C, and starts up under control of the slow-start circuit.

Status (STATUS)

The status pin is an open drain output that indicates when internal conditions are sufficient for proper operation. STATUS can be coupled back to a system controller or monitor circuit to indicate that the termination or tracking regulator is ready for start up. STATUS is high impedance when the TPS54672 is operating or ready to be enabled.

STATUS is active low if any of the following occur:

- VIN < UVLO threshold
- VBIAS or internal reference have not settled.
- Thermal shutdown is active.

PACKAGING INFORMATION

Orderable Device	Status ⁽¹⁾	Package Type	Package Drawing	Pins	Package Qty	Eco Plan ⁽²⁾	Lead/Ball Finish	MSL Peak Temp ⁽³⁾
TPS54672PWP	ACTIVE	HTSSOP	PWP	28	50	Green (RoHS & no Sb/Br)	CU NIPDAU	Level-2-260C-1 YEAR
TPS54672PWPG4	ACTIVE	HTSSOP	PWP	28	50	Green (RoHS & no Sb/Br)	CU NIPDAU	Level-2-260C-1 YEAR
TPS54672PWPR	ACTIVE	HTSSOP	PWP	28	2000	Green (RoHS & no Sb/Br)	CU NIPDAU	Level-2-260C-1 YEAR
TPS54672PWPRG4	ACTIVE	HTSSOP	PWP	28	2000	Green (RoHS & no Sb/Br)	CU NIPDAU	Level-2-260C-1 YEAR

⁽¹⁾ The marketing status values are defined as follows:

ACTIVE: Product device recommended for new designs.

LIFEBUY: TI has announced that the device will be discontinued, and a lifetime-buy period is in effect.

NRND: Not recommended for new designs. Device is in production to support existing customers, but TI does not recommend using this part in a new design.

PREVIEW: Device has been announced but is not in production. Samples may or may not be available.

OBSOLETE: TI has discontinued the production of the device.

⁽²⁾ Eco Plan - The planned eco-friendly classification: Pb-Free (RoHS) or Green (RoHS & no Sb/Br) - please check <http://www.ti.com/productcontent> for the latest availability information and additional product content details.

TBD: The Pb-Free/Green conversion plan has not been defined.

Pb-Free (RoHS): TI's terms "Lead-Free" or "Pb-Free" mean semiconductor products that are compatible with the current RoHS requirements for all 6 substances, including the requirement that lead not exceed 0.1% by weight in homogeneous materials. Where designed to be soldered at high temperatures, TI Pb-Free products are suitable for use in specified lead-free processes.

Green (RoHS & no Sb/Br): TI defines "Green" to mean Pb-Free (RoHS compatible), and free of Bromine (Br) and Antimony (Sb) based flame retardants (Br or Sb do not exceed 0.1% by weight in homogeneous material)

⁽³⁾ MSL, Peak Temp. -- The Moisture Sensitivity Level rating according to the JEDEC industry standard classifications, and peak solder temperature.

Important Information and Disclaimer:The information provided on this page represents TI's knowledge and belief as of the date that it is provided. TI bases its knowledge and belief on information provided by third parties, and makes no representation or warranty as to the accuracy of such information. Efforts are underway to better integrate information from third parties. TI has taken and continues to take reasonable steps to provide representative and accurate information but may not have conducted destructive testing or chemical analysis on incoming materials and chemicals. TI and TI suppliers consider certain information to be proprietary, and thus CAS numbers and other limited information may not be available for release.

In no event shall TI's liability arising out of such information exceed the total purchase price of the TI part(s) at issue in this document sold by TI to Customer on an annual basis.

PWP (R-PDSO-G**) 20 PIN SHOWN

PowerPAD™ PLASTIC SMALL-OUTLINE PACKAGE

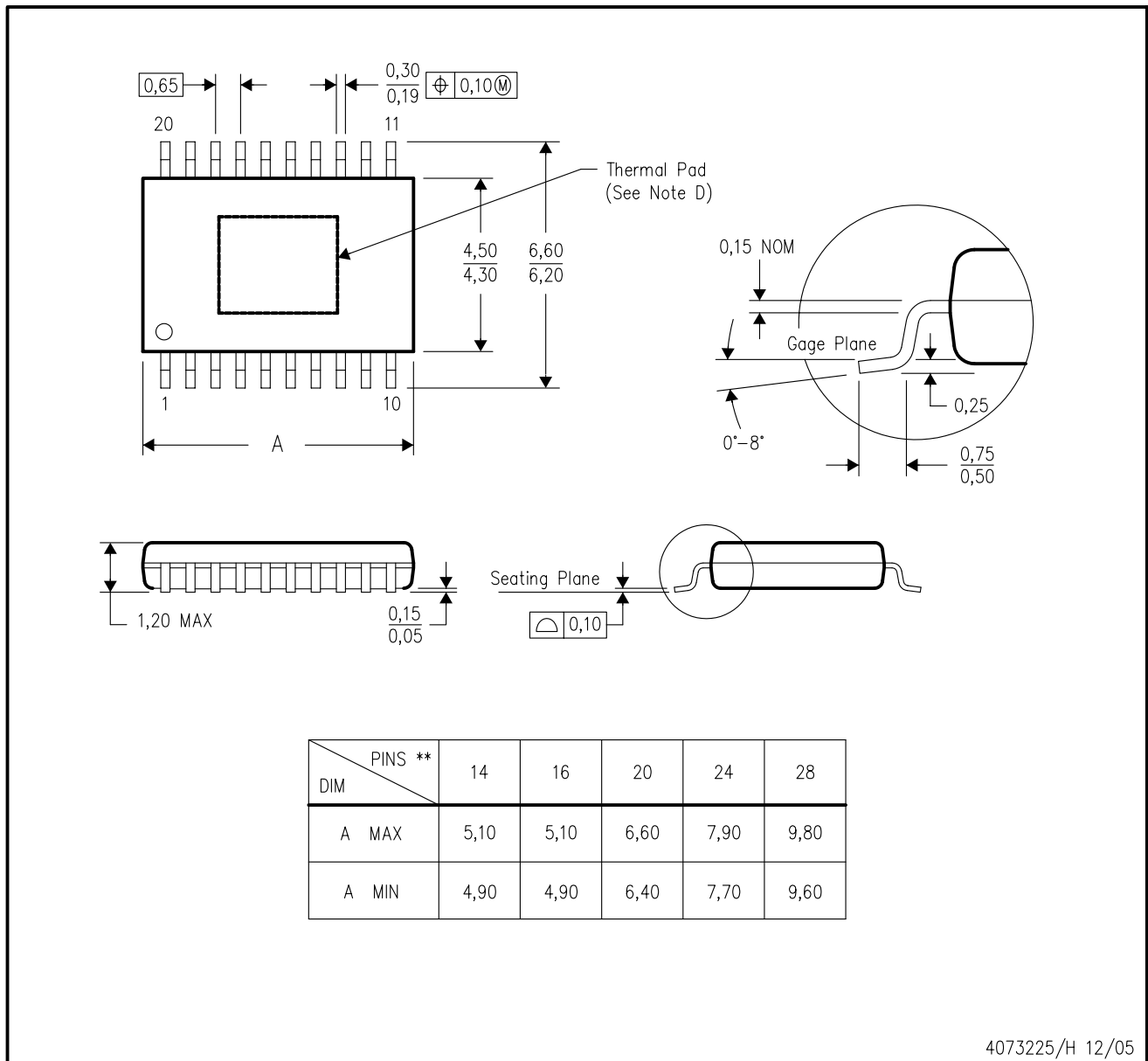

4073225/H 12/05

- NOTES:
- A. All linear dimensions are in millimeters.
 - B. This drawing is subject to change without notice.
 - C. Body dimensions do not include mold flash or protrusions. Mold flash and protrusion shall not exceed 0.15 per side.
 - D. This package is designed to be soldered to a thermal pad on the board. Refer to Technical Brief, PowerPad Thermally Enhanced Package, Texas Instruments Literature No. SLMA002 for information regarding recommended board layout. This document is available at www.ti.com <<http://www.ti.com>>.
 - E. Falls within JEDEC MO-153

PowerPAD is a trademark of Texas Instruments.

IMPORTANT NOTICE

Texas Instruments Incorporated and its subsidiaries (TI) reserve the right to make corrections, modifications, enhancements, improvements, and other changes to its products and services at any time and to discontinue any product or service without notice. Customers should obtain the latest relevant information before placing orders and should verify that such information is current and complete. All products are sold subject to TI's terms and conditions of sale supplied at the time of order acknowledgment.

TI warrants performance of its hardware products to the specifications applicable at the time of sale in accordance with TI's standard warranty. Testing and other quality control techniques are used to the extent TI deems necessary to support this warranty. Except where mandated by government requirements, testing of all parameters of each product is not necessarily performed.

TI assumes no liability for applications assistance or customer product design. Customers are responsible for their products and applications using TI components. To minimize the risks associated with customer products and applications, customers should provide adequate design and operating safeguards.

TI does not warrant or represent that any license, either express or implied, is granted under any TI patent right, copyright, mask work right, or other TI intellectual property right relating to any combination, machine, or process in which TI products or services are used. Information published by TI regarding third-party products or services does not constitute a license from TI to use such products or services or a warranty or endorsement thereof. Use of such information may require a license from a third party under the patents or other intellectual property of the third party, or a license from TI under the patents or other intellectual property of TI.

Reproduction of information in TI data books or data sheets is permissible only if reproduction is without alteration and is accompanied by all associated warranties, conditions, limitations, and notices. Reproduction of this information with alteration is an unfair and deceptive business practice. TI is not responsible or liable for such altered documentation.

Resale of TI products or services with statements different from or beyond the parameters stated by TI for that product or service voids all express and any implied warranties for the associated TI product or service and is an unfair and deceptive business practice. TI is not responsible or liable for any such statements.

Following are URLs where you can obtain information on other Texas Instruments products and application solutions:

Products		Applications	
Amplifiers	amplifier.ti.com	Audio	www.ti.com/audio
Data Converters	dataconverter.ti.com	Automotive	www.ti.com/automotive
DSP	dsp.ti.com	Broadband	www.ti.com/broadband
Interface	interface.ti.com	Digital Control	www.ti.com/digitalcontrol
Logic	logic.ti.com	Military	www.ti.com/military
Power Mgmt	power.ti.com	Optical Networking	www.ti.com/opticalnetwork
Microcontrollers	microcontroller.ti.com	Security	www.ti.com/security
		Telephony	www.ti.com/telephony
		Video & Imaging	www.ti.com/video
		Wireless	www.ti.com/wireless

Mailing Address: Texas Instruments
Post Office Box 655303 Dallas, Texas 75265