

Recommended schedule

Day 1

Topics: *RLC circuits*

Questions: *1 through 15*

Lab Exercise: *Passive RC filter circuit design (question 61)*

Day 2

Topics: *RLC circuits and AC bridge circuits*

Questions: *16 through 30*

Lab Exercise: *Passive RC filter circuit design (question 61, continued)*

Day 3

Topics: *Series and parallel resonance*

Questions: *31 through 45*

Lab Exercise: *Measuring inductance by series resonance (question 62)*

Day 4

Topics: *Resonant filter circuits, bandwidth, and Q*

Questions: *46 through 60*

Lab Exercise: *Passive resonant filter circuit (question 63)*

Day 5

Exam 3: *includes Passive RC filter circuit design performance assessment*

Troubleshooting Assessment due: *Variable phase shift bridge circuit (question 64)*

Question 65: *Troubleshooting log*

Question 66: *Sample troubleshooting assessment grading criteria*

Practice and challenge problems

Questions: *67 through the end of the worksheet*

Skill standards addressed by this course section

EIA Raising the Standard: Electronics Technician Skills for Today and Tomorrow, June 1994

C Technical Skills – AC circuits

- C.02 Demonstrate an understanding of the properties of an AC signal.
- C.21 Understand principles and operations of AC series and parallel resonant circuits.
- C.22 Fabricate and demonstrate AC series and parallel resonant circuits.
- C.23 Troubleshoot and repair AC series and parallel resonant circuits.
- C.24 Understand principles and operations of AC RC, RL, and RLC circuits.
- C.25 Fabricate and demonstrate AC RC, RL, and RLC circuits.
- C.26 Troubleshoot and repair AC RC, RL, and RLC circuits.
- C.27 Understand principles and operations of AC frequency selective filter circuits.
- C.28 Fabricate and demonstrate AC frequency selective filter circuits.
- C.29 Troubleshoot and repair AC frequency selective filter circuits.

B Basic and Practical Skills – Communicating on the Job

- B.01 Use effective written and other communication skills. *Met by group discussion and completion of labwork.*
- B.03 Employ appropriate skills for gathering and retaining information. *Met by research and preparation prior to group discussion.*
- B.04 Interpret written, graphic, and oral instructions. *Met by completion of labwork.*
- B.06 Use language appropriate to the situation. *Met by group discussion and in explaining completed labwork.*
- B.07 Participate in meetings in a positive and constructive manner. *Met by group discussion.*
- B.08 Use job-related terminology. *Met by group discussion and in explaining completed labwork.*
- B.10 Document work projects, procedures, tests, and equipment failures. *Met by project construction and/or troubleshooting assessments.*

C Basic and Practical Skills – Solving Problems and Critical Thinking

- C.01 Identify the problem. *Met by research and preparation prior to group discussion.*
- C.03 Identify available solutions and their impact including evaluating credibility of information, and locating information. *Met by research and preparation prior to group discussion.*
- C.07 Organize personal workloads. *Met by daily labwork, preparatory research, and project management.*
- C.08 Participate in brainstorming sessions to generate new ideas and solve problems. *Met by group discussion.*

D Basic and Practical Skills – Reading

- D.01 Read and apply various sources of technical information (e.g. manufacturer literature, codes, and regulations). *Met by research and preparation prior to group discussion.*

E Basic and Practical Skills – Proficiency in Mathematics

- E.01 Determine if a solution is reasonable.
- E.02 Demonstrate ability to use a simple electronic calculator.
- E.05 Solve problems and [sic] make applications involving integers, fractions, decimals, percentages, and ratios using order of operations.
- E.06 Translate written and/or verbal statements into mathematical expressions.
- E.09 Read scale on measurement device(s) and make interpolations where appropriate. *Met by oscilloscope usage.*
- E.12 Interpret and use tables, charts, maps, and/or graphs.
- E.13 Identify patterns, note trends, and/or draw conclusions from tables, charts, maps, and/or graphs.
- E.15 Simplify and solve algebraic expressions and formulas.
- E.16 Select and use formulas appropriately.
- E.17 Understand and use scientific notation.
- E.20 Graph functions.
- E.26 Apply Pythagorean theorem.

E.27 Identify basic functions of sine, cosine, and tangent.

E.28 Compute and solve problems using basic trigonometric functions.

Common areas of confusion for students

Difficult concept: *Conductance, susceptance, and admittance.*

Conductance, symbolized by the letter G , is the mathematical reciprocal of resistance ($\frac{1}{R}$). Students typically encounter this quantity in their DC studies and quickly ignore it. In AC calculations, however, conductance and its AC counterparts (*susceptance*, the reciprocal of reactance $B = \frac{1}{X}$ and *admittance*, the reciprocal of impedance $Y = \frac{1}{Z}$) are very necessary in order to draw phasor diagrams for parallel networks.

Difficult concept: *Capacitance adding in parallel; capacitive reactance and impedance adding in series.*

When students first encounter capacitance, they are struck by how this quantity adds when capacitors are connected in *parallel*, not in series as it is for resistors and inductors. They are surprised again, though, when they discover that the opposition to current offered by capacitors (either as scalar reactance or phasor impedance) adds in series just as resistance adds in series and inductive reactance/impedance adds in series. Remember: *ohms* always add in series, no matter what their source(s); only *farads* add in parallel (omitting *siemens* or *mhos*, the units for conductance and admittance and susceptance, which of course also add in parallel).

Difficult concept: *Identifying filter circuit types.*

Many students have a predisposition to memorization (as opposed to comprehension of concepts), and so when approaching filter circuits they try to identify the various types by memorizing the positions of reactive components. As I like to tell my students, *memory will fail you*, and so a better approach is to develop analytical techniques by which you may determine circuit function based on "first principles" of circuits. The approach I recommend begins by identifying component impedance (open or short) for very low and very high frequencies, respectively, then qualitatively analyzing voltage drops under those extreme conditions. If a filter circuit outputs a strong voltage at low frequencies and a weak voltage at high frequencies then it must be a low-pass filter. If it outputs a weak voltage at both low and high frequencies then it must be a band-pass filter, etc.

Difficult concept: *The practical purpose(s) for filter circuits.*

Bode plots show how filter circuits respond to inputs of changing frequency, but this is not how filters are typically used in real applications. Rarely does one find a filter circuit subjected to one particular frequency at a time – usually a simultaneous mix of frequencies are seen at the input, and it is the filter's job to select a particular range of frequencies to pass through from that simultaneous mix. Understanding the superposition theorem precedes an understanding of how filter circuits are practically used.

Questions

Question 1

Capacitors and inductors are complementary components – both conceptually and mathematically, they seem to be almost exact opposites of each other. Calculate the total impedance of this series-connected inductor and capacitor network:

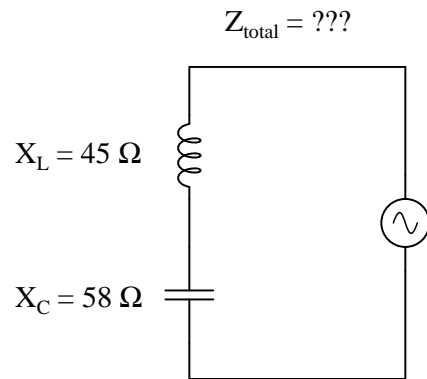

[file 00851](#)

Question 2

Write an equation that solves for the impedance of this series circuit. The equation need not solve for the phase angle between voltage and current, but merely provide a scalar figure for impedance (in ohms):

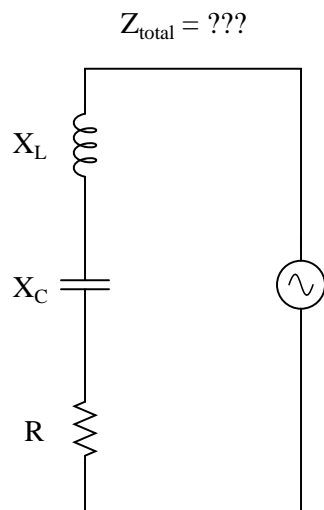

[file 00852](#)

Question 3

Write an equation that solves for the admittance of this parallel circuit. The equation need not solve for the phase angle between voltage and current, but merely provide a scalar figure for admittance (in siemens):

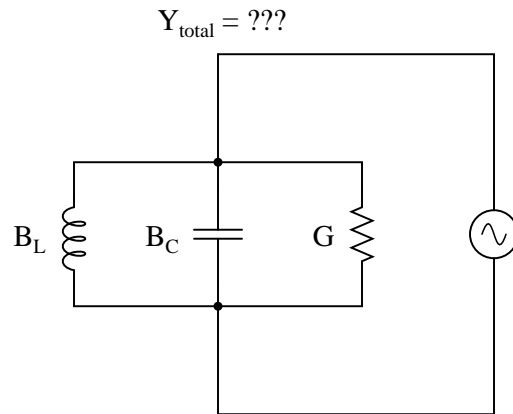

[file 00854](#)

Question 4

Calculate the total impedance of this parallel network, given a signal frequency of 12 kHz:

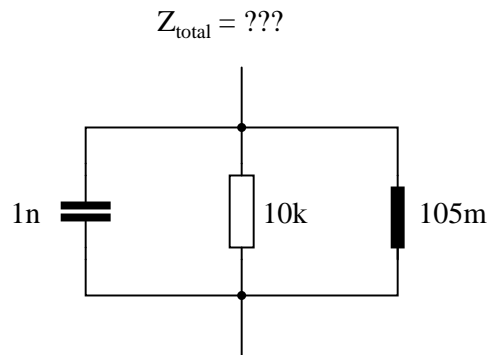

[file 01541](#)

Question 5

Is this circuit's overall behavior capacitive or inductive? In other words, from the perspective of the AC voltage source, does it "appear" as though a capacitor is being powered, or an inductor?

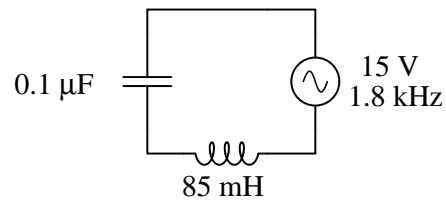

Now, suppose we take these same components and re-connect them in parallel rather than series. Does this change the circuit's overall "appearance" to the source? Does the source now "see" an equivalent capacitor or an equivalent inductor? Explain your answer.

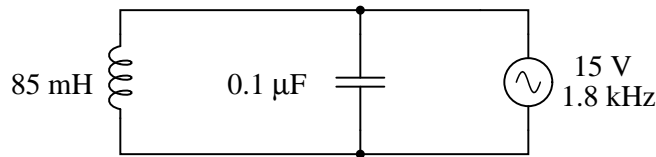

[file 01554](#)

Question 6

An AC electric motor operating under loaded conditions draws a current of 11 amps (RMS) from the 120 volt (RMS) 60 Hz power lines. The measured phase shift between voltage and current for this motor is 34° , with voltage leading current.

Determine the equivalent parallel combination of resistance (R) and inductance (L) that is electrically equivalent to this operating motor.

[file 01542](#)

Question 7

Suppose you are building a circuit and you need an impedance of $1500 \Omega \angle -41^\circ$ at a frequency of 600 Hz. What combination of components could you connect together in series to achieve this precise impedance?

[file 00644](#)

Question 8

It is often useful in AC circuit analysis to be able to convert a series combination of resistance and reactance into an equivalent parallel combination of conductance and susceptance, or visa-versa:

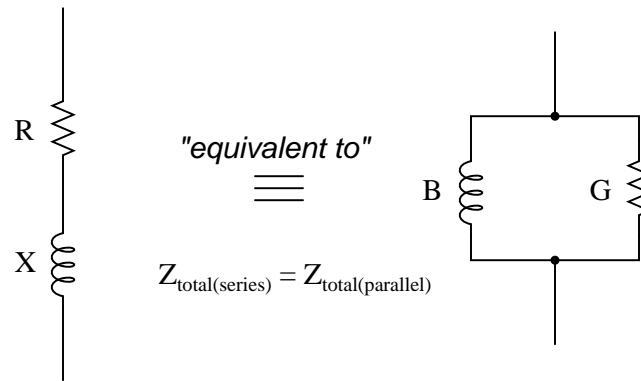

We know that resistance (R), reactance (X), and impedance (Z), as scalar quantities, relate to one another trigonometrically in a series circuit. We also know that conductance (G), susceptance (B), and admittance (Y), as scalar quantities, relate to one another trigonometrically in a parallel circuit:

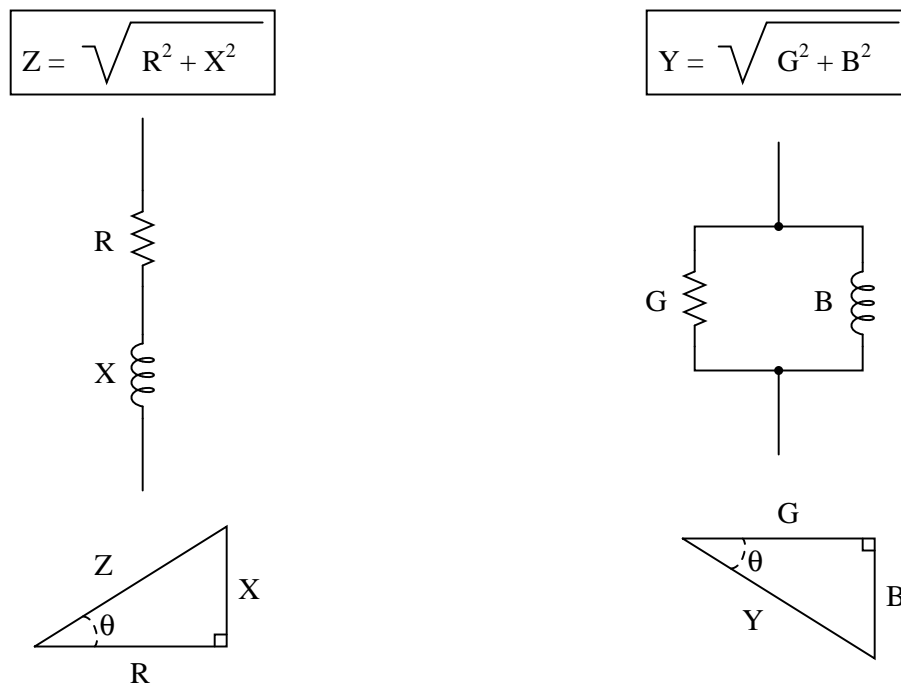

If these two circuits are truly equivalent to one another, having the same total impedance, then their representative triangles should be geometrically similar (identical angles, same proportions of side lengths). With equal proportions, $\frac{R}{Z}$ in the series circuit triangle should be the same ratio as $\frac{G}{Y}$ in the parallel circuit triangle, that is $\frac{R}{Z} = \frac{G}{Y}$.

Building on this proportionality, prove the following equation to be true:

$$R_{\text{series}}R_{\text{parallel}} = Z_{\text{total}}^2$$

After this, derive a similar equation relating the series and parallel reactances (X_{series} and X_{parallel}) with total impedance (Z_{total}).

Question 9

Determine an equivalent *parallel* RC network for the series RC network shown on the left:

Equivalent RC networks

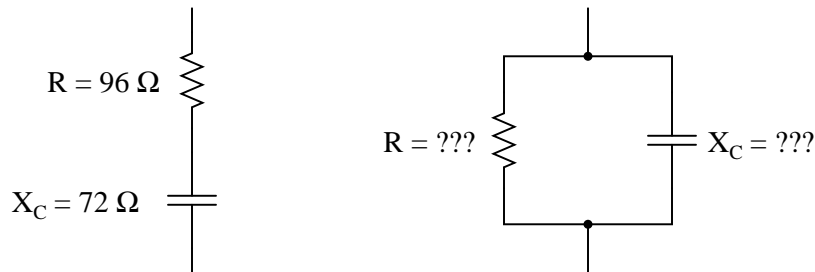

Note that I have already provided a value for the capacitor's reactance (X_C), which of course will be valid only for a particular frequency. Determine what values of resistance (R) and reactance (X_C) in the parallel network will yield the exact same total impedance (Z_T) at the same signal frequency.

[file 01540](#)

Question 10

Determine the equivalent parallel-connected resistor and inductor values for this series circuit:

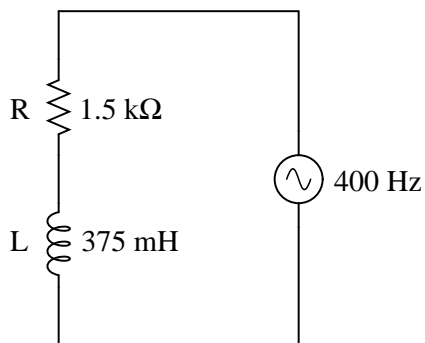

Also, express the total impedance of either circuit (since they are electrically equivalent to one another, they should have the same total impedance) in *complex form*. That is, express \mathbf{Z} as a quantity with both a magnitude and an angle.

[file 00855](#)

Question 11

Determine the equivalent series-connected resistor and capacitor values for this parallel circuit:

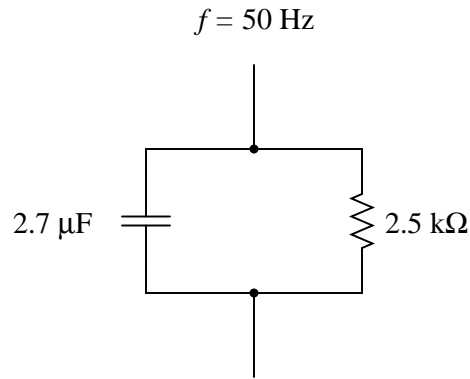

Also, express the total impedance of either circuit (since they are electrically equivalent to one another, they should have the same total impedance) in *complex form*. That is, express \mathbf{Z} as a quantity with both a magnitude and an angle.

[file 00858](#)

Question 12

Calculate the impedance of a 145 mH inductor connected in series with 750 Ω resistor at a frequency of 1 kHz, then determine the necessary resistor and inductor values to create the exact same total impedance in a *parallel* configuration.

[file 00645](#)

Question 13

It is not uncommon to see impedances represented in AC circuits as boxes, rather than as combinations of R, L, and/or C. This is simply a convenient way to represent what may be complex sub-networks of components in a larger AC circuit:

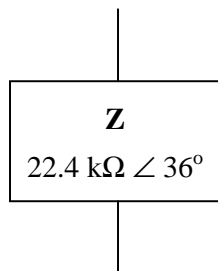

We know that any given impedance may be represented by a simple, two-component circuit: either a resistor and a reactive component connected in series, or a resistor and a reactive component connected in parallel. Assuming a circuit frequency of 250 Hz, determine what combination of series-connected components will be equivalent to this "box" impedance, and also what combination of parallel-connected components will be equivalent to this "box" impedance.

[file 00859](#)

Question 14

It is not uncommon to see impedances represented in AC circuits as boxes, rather than as combinations of R, L, and/or C. This is simply a convenient way to represent what may be complex sub-networks of components in a larger AC circuit:

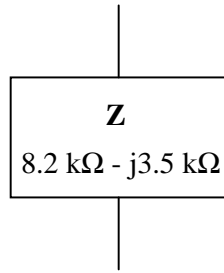

We know that any given impedance may be represented by a simple, two-component circuit: either a resistor and a reactive component connected in series, or a resistor and a reactive component connected in parallel. Assuming a circuit frequency of 700 Hz, determine what combination of series-connected components will be equivalent to this "box" impedance, and also what combination of parallel-connected components will be equivalent to this "box" impedance.

[file 02118](#)

Question 15

Complex quantities may be expressed in either *rectangular* or *polar* form. Mathematically, it does not matter which form of expression you use in your calculations.

However, one of these forms relates better to real-world measurements than the other. Which of these mathematical forms (rectangular or polar) relates more naturally to measurements of voltage or current, taken with meters or other electrical instruments? For instance, which form of AC voltage expression, polar or rectangular, best correlates to the total voltage measurement in the following circuit?

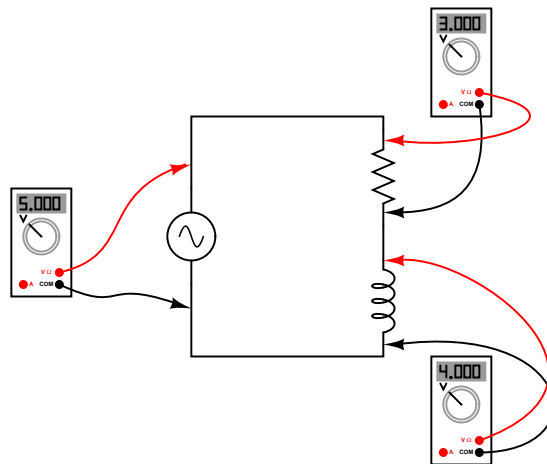

[file 01072](#)

Question 16

Calculate the amount of current through this impedance, and express your answer in both polar and rectangular forms:

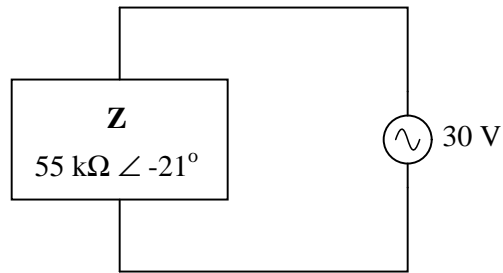

[file 02119](#)

Question 17

Determine the total impedance of this series-parallel network by first converting it into an equivalent network that is either all-series or all-parallel:

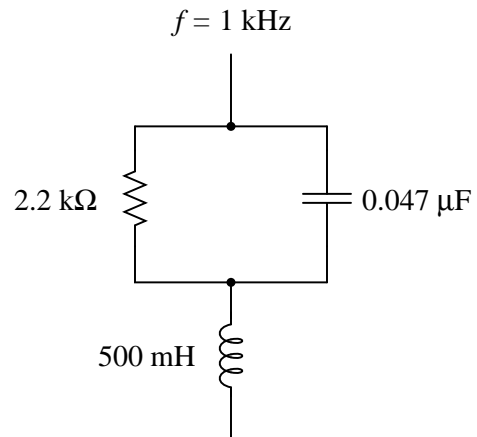

[file 01864](#)

Question 18

Determine the total impedance of this series-parallel network by first converting it into an equivalent network that is either all-series or all-parallel:

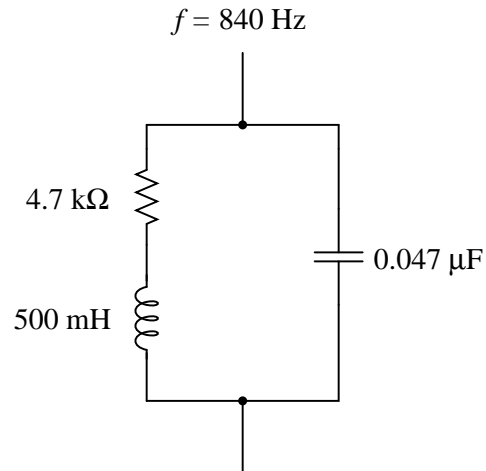

[file 01865](#)

Question 19

Determine the voltage dropped between points **A** and **B** in this circuit:

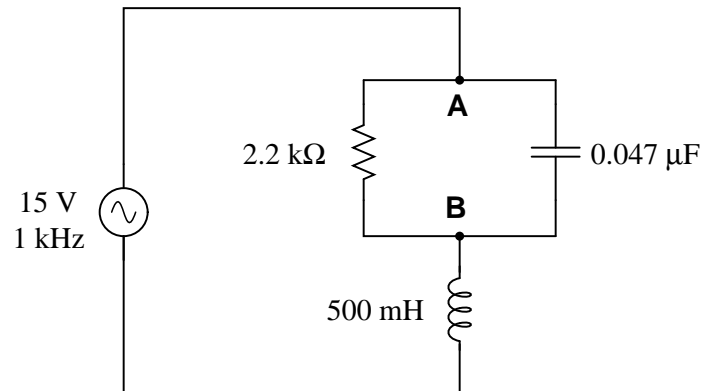

Hint: convert the parallel RC sub-network into a series equivalent first.

[file 02115](#)

Question 20

Determine the current through the series LR branch in this series-parallel circuit:

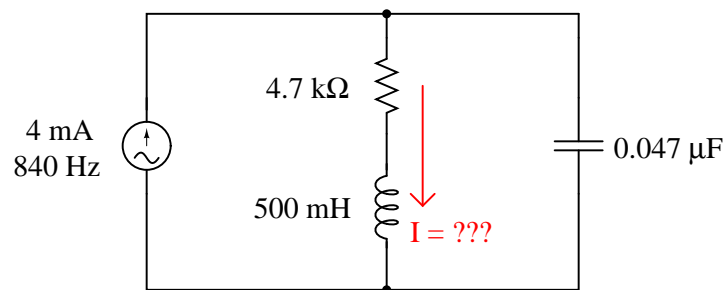

Hint: convert the series LR sub-network into a parallel equivalent first.
[file 02116](#)

Test leads for DC voltmeters are usually just two individual lengths of wire connecting the meter to a pair of probes. For highly sensitive instruments, a special type of two-conductor cable called *coaxial cable* is generally used instead of two individual wires. Coaxial cable – where a center conductor is "shielded" by an outer braid or foil that serves as the other conductor – has excellent immunity to induced "noise" from electric and magnetic fields:

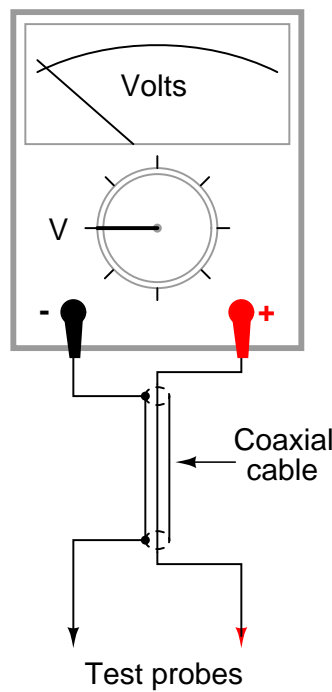

When measuring high-frequency AC voltages, however, the parasitic capacitance and inductance of the coaxial cable may present problems. We may represent these distributed characteristics of the cable as "lumped" parameters: a single capacitor and a single inductor modeling the cable's behavior:

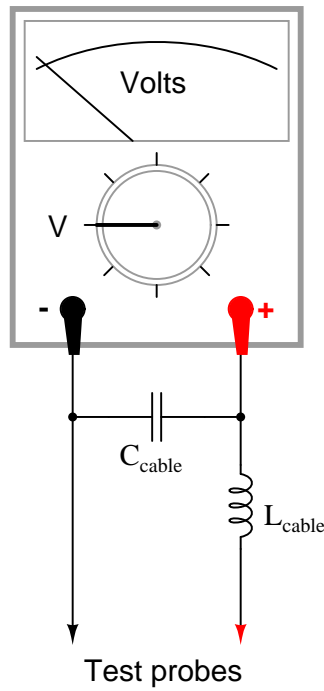

Typical parasitic values for a 10-foot cable would be 260 pF of capacitance and 650 μ H of inductance. The voltmeter itself, of course, is not without its own inherent impedances, either. For the sake of this example, let's consider the meter's "input impedance" to be a simple resistance of 1 M Ω .

Calculate what voltage the meter would register when measuring the output of a 20 volt AC source, at these frequencies:

- $f = 1 \text{ Hz}$; $V_{meter} =$
- $f = 1 \text{ kHz}$; $V_{meter} =$
- $f = 10 \text{ kHz}$; $V_{meter} =$
- $f = 100 \text{ kHz}$; $V_{meter} =$
- $f = 1 \text{ MHz}$; $V_{meter} =$

file 00641

Question 22

The voltage measurement range of a DC instrument may easily be "extended" by connecting an appropriately sized resistor in series with one of its test leads:

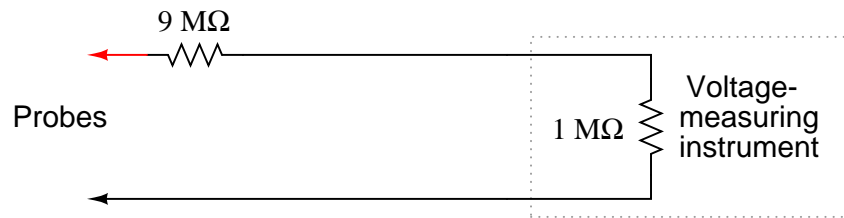

In the example shown here, the multiplication ratio with the 9 MΩ resistor in place is 10:1, meaning that an indication of 3.5 volts at the instrument corresponds to an actual measured voltage of 35 volts between the probes.

While this technique works very well when measuring DC voltage, it does not do so well when measuring AC voltage, due to the parasitic capacitance of the cable connecting the test probes to the instrument (parasitic cable *inductance* has been omitted from this diagram for simplicity):

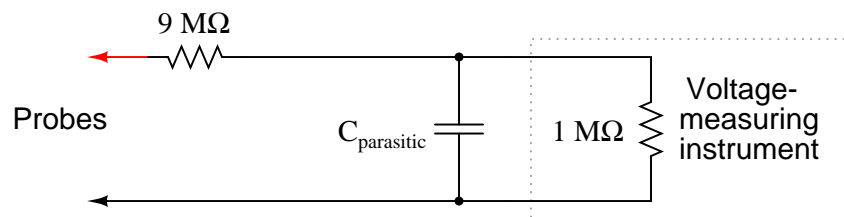

To see the effects of this capacitance for yourself, calculate the voltage at the instrument input terminals assuming a parasitic capacitance of 180 pF and an AC voltage source of 10 volts, for the following frequencies:

- $f = 10 \text{ Hz}$; $V_{\text{instrument}} =$
- $f = 1 \text{ kHz}$; $V_{\text{instrument}} =$
- $f = 10 \text{ kHz}$; $V_{\text{instrument}} =$
- $f = 100 \text{ kHz}$; $V_{\text{instrument}} =$
- $f = 1 \text{ MHz}$; $V_{\text{instrument}} =$

The debilitating effect of cable capacitance may be compensated for with the addition of another capacitor, connected in parallel with the 9 MΩ range resistor. If we are trying to maintain a voltage division ratio of 10:1, this "compensating" capacitor must be $\frac{1}{9}$ the value of the capacitance parallel to the instrument input:

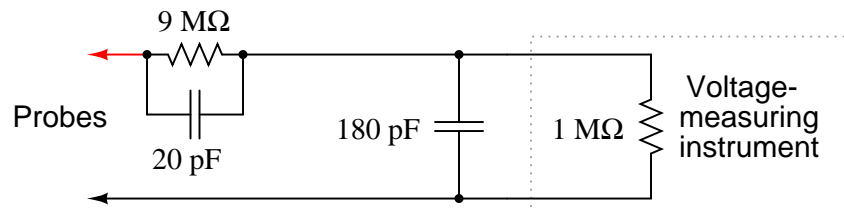

Re-calculate the voltage at the instrument input terminals with this compensating capacitor in place. You should notice quite a difference in instrument voltages across this frequency range!

- $f = 10 \text{ Hz}$; $V_{\text{instrument}} =$
- $f = 1 \text{ kHz}$; $V_{\text{instrument}} =$
- $f = 10 \text{ kHz}$; $V_{\text{instrument}} =$

- $f = 100 \text{ kHz}$; $V_{instrument} =$
- $f = 1 \text{ MHz}$; $V_{instrument} =$

Complete your answer by explaining why the compensation capacitor is able to "flatten" the response of the instrument over a wide frequency range.

[file 00642](#)

Question 23

In general terms, describe what must be done to *balance* this bridge circuit. What, exactly, does the term "balance" mean in this context?

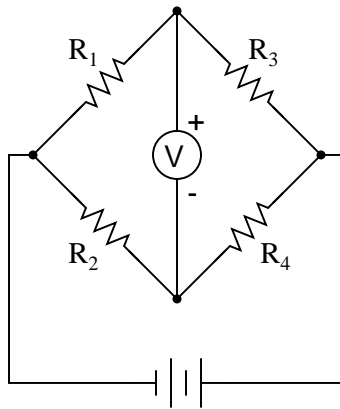

Also, write an equation containing only the four resistor values (R_1 , R_2 , R_3 , and R_4) showing their relationship to one another in a balanced condition.

[file 00544](#)

Question 24

Explain why this bridge circuit can *never* achieve balance:

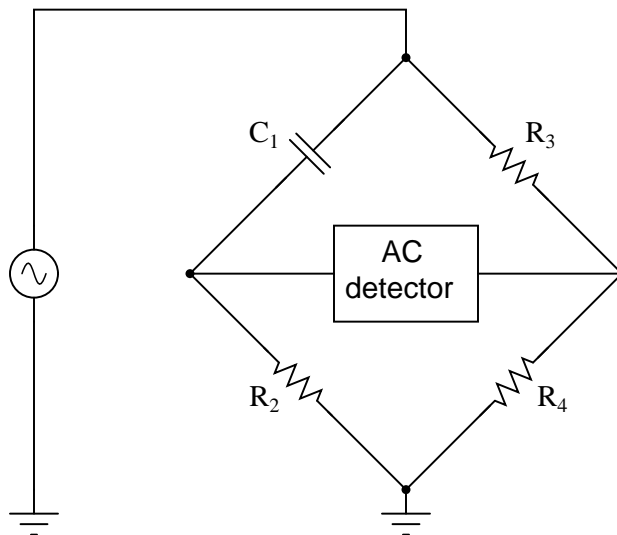

[file 01862](#)

Question 25

Calculate the impedance value necessary to balance this AC bridge, expressing your answer in both polar and rectangular forms:

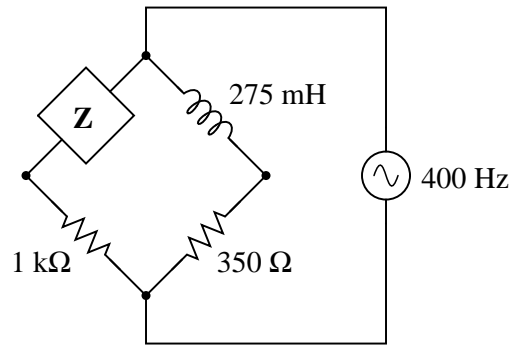

[file 01863](#)

Question 26

Calculate the impedance value necessary to balance this AC bridge, expressing your answer in both polar and rectangular forms:

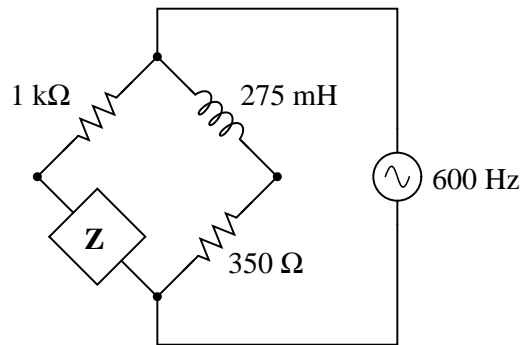

Also, describe what sort of device might be appropriate to serve as a "null detector" to indicate when bridge balance has been achieved, and where this device would be connected to in the bridge circuit.

[file 00861](#)

Question 27

Determine the phase shift of the output voltage (V_{out}) with reference to the source voltage (0°) for each of the two switch positions, assuming the source frequency is such that $X_C = R$:

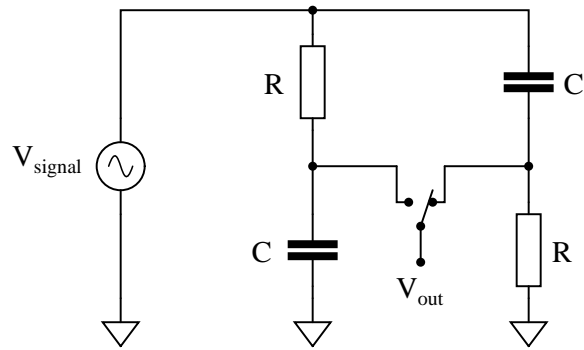

Note: you should be able to do all the necessary math mentally, without the aid of a calculating device!
[file 03662](#)

Question 28

This interesting bridge circuit is a variable phase-shifter. It works best when the excitation frequency is such that $X_C = R$ in each arm of the bridge:

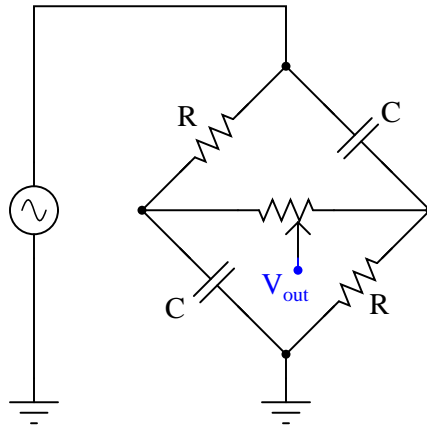

Supposing that X_C does equal R in each arm of the bridge, and that the potentiometer resistance is sufficiently high to limit current through it to a negligible level (in other words, $R_{\text{pot}} \gg R$). Calculate the phase shift of V_{out} with respect to the excitation source voltage when:

- The potentiometer wiper is fully left:
- The potentiometer wiper is fully right:
- The potentiometer wiper is perfectly centered:

[file 01599](#)

Question 29

This phase-shifting bridge circuit is supposed to provide an output voltage with a variable phase shift from -45° (lagging) to $+45^\circ$ (leading), depending on the position of the potentiometer wiper:

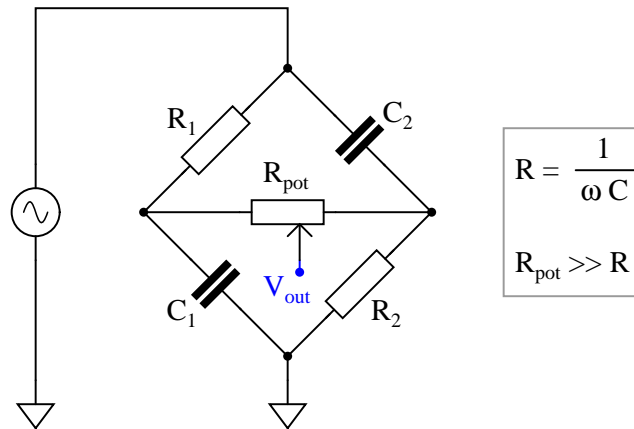

Suppose, though, that there is a solder "bridge" between the terminals of resistor R_1 on the circuit board. What effect will this fault have on the output of the circuit? Be as complete as you can in your answer.

[file 03670](#)

Question 30

This phase-shifting bridge circuit is supposed to provide an output voltage with a variable phase shift from -45° (lagging) to $+45^\circ$ (leading), depending on the position of the potentiometer wiper:

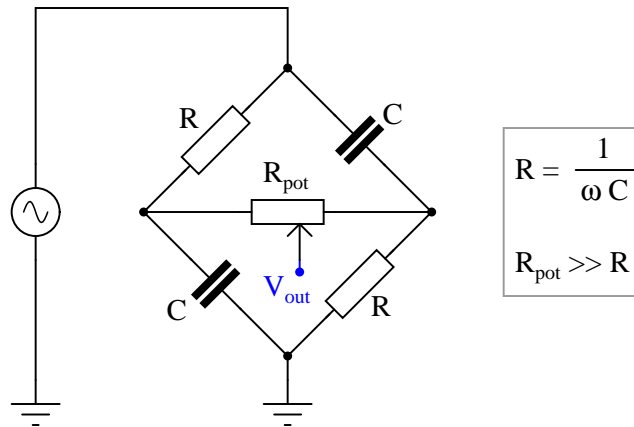

Suppose, though, that the output signal registers as it should with the potentiometer wiper fully to the right, but diminishes greatly in amplitude as the wiper is moved to the left, until there is practically zero output voltage at the full-left position. Identify a likely failure that could cause this to happen, and explain why this failure could account for the circuit's strange behavior.

[file 03466](#)

Question 31

If a metal bar is struck against a hard surface, the bar will "ring" with a characteristic frequency. This is the fundamental principle upon which *tuning forks* work:

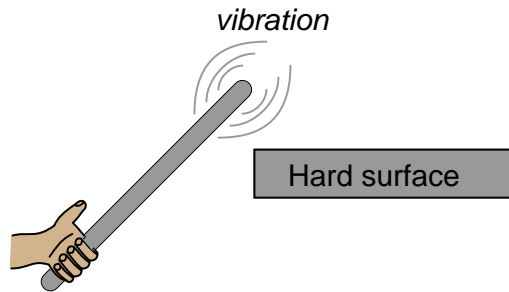

The ability of any physical object to "ring" like this after being struck is dependent upon two complementary properties: *mass* and *elasticity*. An object must possess both mass and a certain amount of "springiness" in order to physically resonate.

Describe what would happen to the resonant frequency of a metal bar if it were made of a more elastic (less "stiff") metal? What would happen to the resonant frequency if an extra amount of mass were added to the end being struck?

file 00600

Question 32

This simple electric circuit is capable of *resonance*, whereby voltage and current oscillate at a frequency characteristic to the circuit:

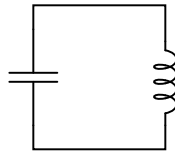

In a mechanical resonant system – such as a tuning fork, a bell, or a guitar string – resonance occurs because the complementary properties of *mass* and *elasticity* exchange energy back and forth between each other in *kinetic* and *potential* forms, respectively. Explain how energy is stored and transferred back and forth between the capacitor and inductor in the resonant circuit shown in the illustration, and identify which of these components stores energy in kinetic form, and which stores energy in potential form.

file 00601

Question 33

If an oscilloscope is set up for "single-sweep" triggering and connected to a DC-excited resonant circuit such as the one shown in the following schematic, the resulting oscillation will last just a short time (after momentarily pressing and releasing the pushbutton switch):

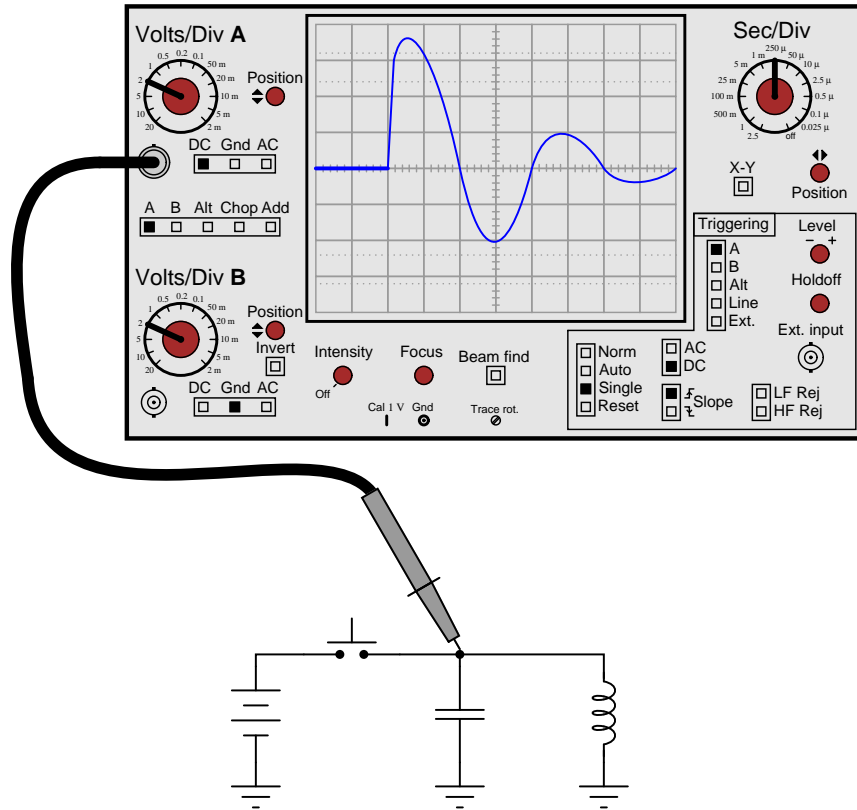

Explain why the oscillations die out, rather than go on forever. Hint: the answer is fundamentally the same as why a swinging pendulum eventually comes to a stop.

[file 03290](#)

Question 34

How may the resonant frequency of this *tank circuit* be increased?

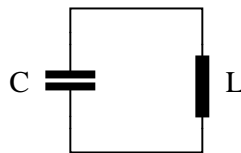

[file 00602](#)

Question 35

Very interesting things happen to resonant systems when they are "excited" by external sources of oscillation. For example, a *pendulum* is a simple example of a mechanically resonant system, and we all know from experience with swings in elementary school that we can make a pendulum achieve very high amplitudes of oscillation if we "oscillate" our legs at just the right times to match the swing's natural (resonant) frequency.

Identify an example of a mechanically resonant system that is "excited" by an external source of oscillations near its resonant frequency. Hint: research the word "resonance" in engineering textbooks, and you are sure to read about some dramatic examples of resonance in action.

[file 00603](#)

Question 36

If a capacitor and an inductor are connected in series, and energized by an AC voltage source with such a frequency that the reactances of each component are $125\ \Omega$ and $170\ \Omega$, respectively, what is the total impedance of the series combination?

[file 00606](#)

Question 37

Suppose we were to build a series "LC" circuit and connect it to a function generator, where we could vary the frequency of the AC voltage powering it:

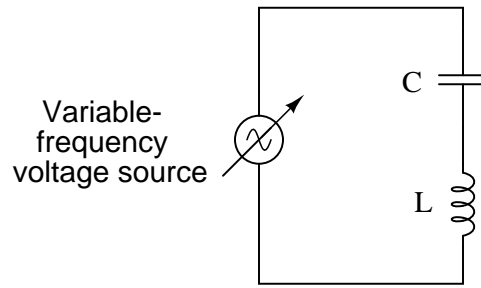

Calculate the amount of current in the circuit, given the following figures:

- Power supply voltage = 3 volts RMS
- Power supply frequency = 100 Hz
- Capacitor = $4.7\ \mu\text{F}$
- Inductor = 100 mH

Then, describe what happens to the circuit current as the frequency is gradually increased.

[file 00604](#)

Question 38

Calculate the power supply frequency at which the reactances of a $33\ \mu\text{F}$ and a 75 mH inductor are exactly equal to each other. Derive a mathematical equation from the individual reactance equations ($X_L = 2\pi fL$ and $X_C = \frac{1}{2\pi fC}$), solving for frequency (f) in terms of L and C in this condition.

Calculate the total impedance of these two components, if they were connected in series, at that frequency.

[file 00607](#)

Question 39

Calculate all voltages and currents in this circuit, at a power supply frequency near resonance:

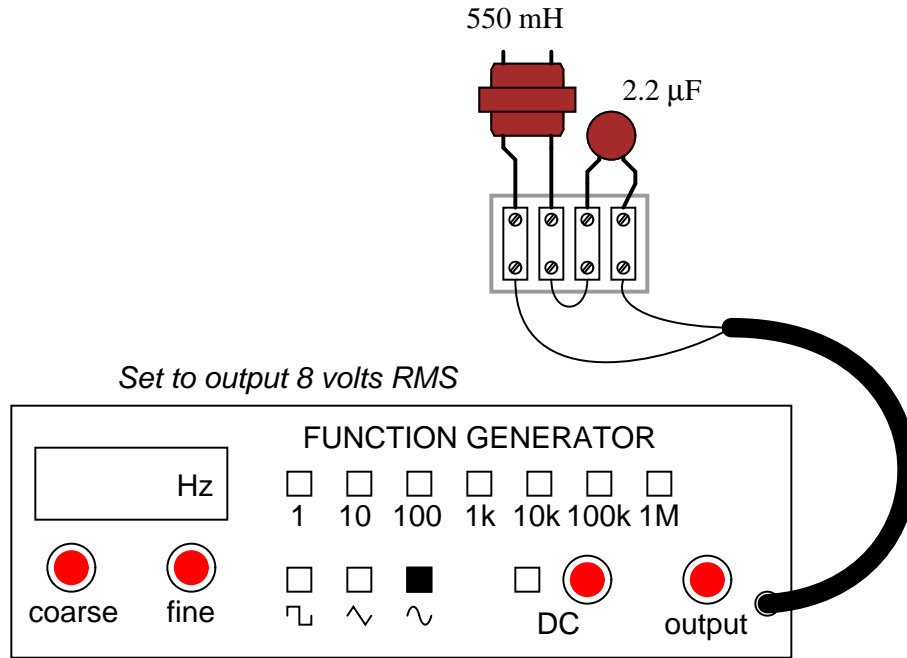

Based on your calculations, what general predictions can you make about series-resonant circuits, in terms of their total impedance, their total current, and their individual component voltage drops?
[file 00608](#)

Question 40

Calculate all voltages and currents in this circuit, at a power supply frequency near resonance:

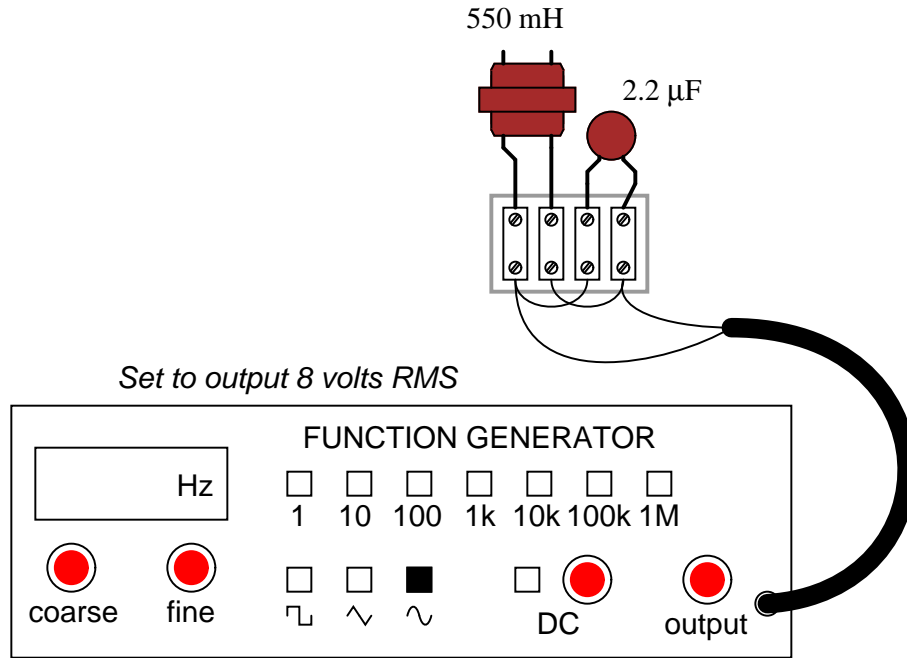

Based on your calculations, what general predictions can you make about parallel-resonant circuits, in terms of their total impedance, their total current, and their individual component currents?

[file 00609](#)

Question 41

Does a series LC circuit "appear" capacitive or inductive (from the perspective of the AC source powering it) when the source frequency is greater than the circuit's resonant frequency? What about a parallel resonant circuit? In each case, explain why.

[file 01563](#)

Question 42

Not only do reactive components unavoidably possess some parasitic ("stray") resistance, but they also exhibit parasitic reactance of the *opposite* kind. For instance, inductors are bound to have a small amount of capacitance built-in, and capacitors are bound to have a small amount of inductance built-in. These effects are not intentional, but they exist anyway.

Describe how a small amount of capacitance comes to exist within an inductor, and how a small amount of inductance comes to exist within a capacitor. Explain what it is about the construction of these two reactive components that allows the existence of "opposite" characteristics.

[file 00593](#)

Question 43

Given the unavoidable presence of parasitic inductance and/or capacitance in any electronic component, what does this mean in terms of *resonance* for single components in AC circuits?

[file 00594](#)

Question 44

A capacitor has been connected in parallel with the solenoid coil to minimize arcing of the switch contacts when opened:

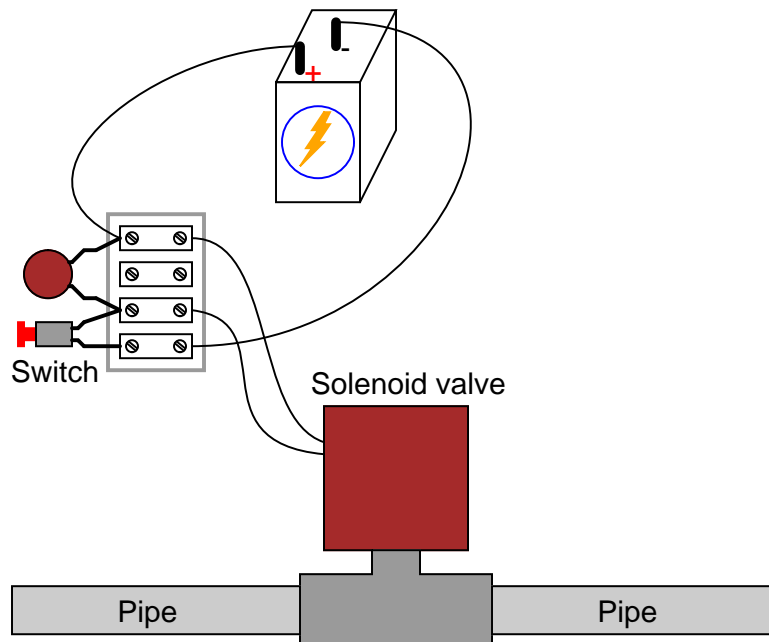

The only problem with this solution is, resonance between the capacitor and the solenoid coil's inductance is causing an oscillating voltage (commonly known as *ringing*) to appear across the terminals of each. This high-frequency "ringing" is generating bursts of radio interference whenever the switch contacts open. Radio interference is not good.

You know that the underlying cause of this "ringing" is resonance, yet you cannot simply remove the capacitor from the circuit because you know that will result in decreased operating life for the switch contacts, as the solenoid's inductive "kickback" will cause excessive arcing. How do you overcome this problem without creating another problem?

[file 00610](#)

Question 45

An alternative to "tank circuit" combinations of L and C in many electronic circuits is a small device known as a *crystal*. Explain how a "crystal" may take the place of a tank circuit, and how it functions.

[file 01869](#)

Question 46

Calculate all voltage drops and current in this LC circuit at each of the given frequencies:

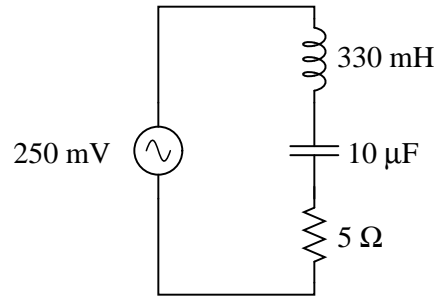

Frequency	V_L	V_C	I_{total}
50 Hz			
60 Hz			
70 Hz			
80 Hz			
90 Hz			
100 Hz			

Also, calculate the resonant frequency of this circuit.

[file 01873](#)

Question 47

The following schematic shows the workings of a simple AM radio receiver, with transistor amplifier:

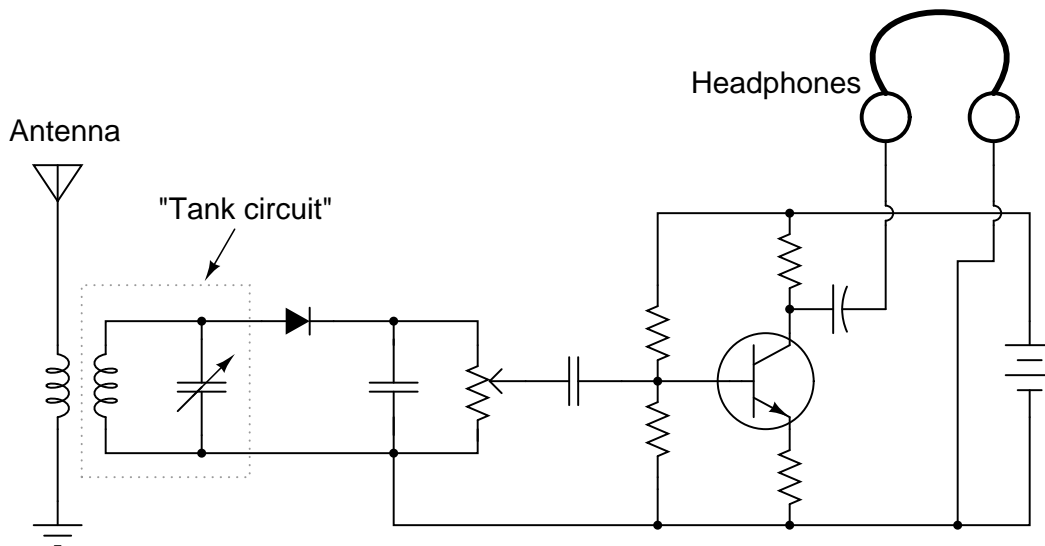

The "tank circuit" formed of a parallel-connected inductor and capacitor network performs a very important filtering function in this circuit. Describe what this filtering function is.

[file 00611](#)

Question 48

Plot the typical frequency responses of four different filter circuits, showing signal output (amplitude) on the vertical axis and frequency on the horizontal axis:

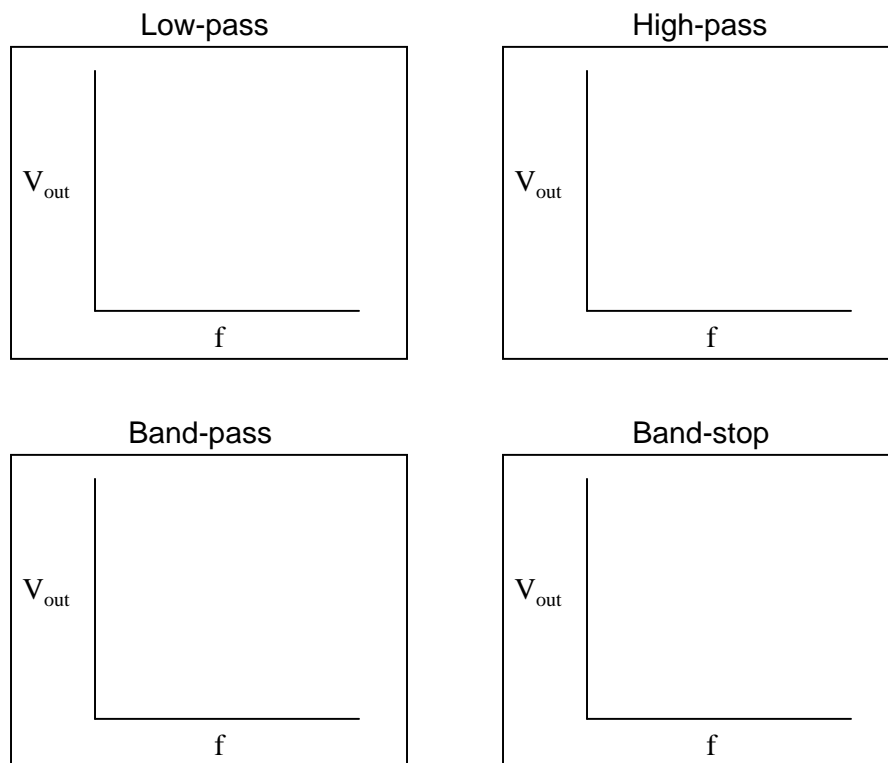

Also, identify and label the *bandwidth* of the filter circuit on each plot.
[file 02571](#)

Question 49

Identify each of these filter types, and explain *how* you were able to positively identify their behaviors:

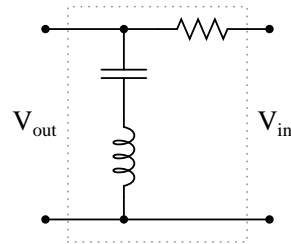
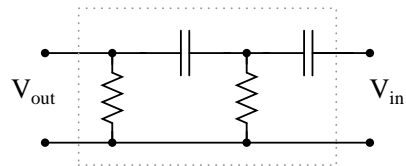
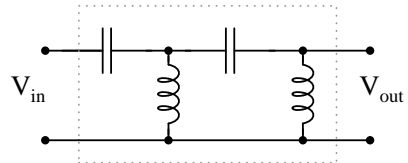
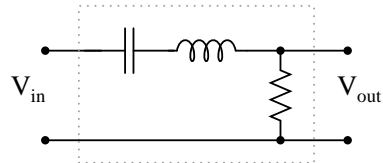
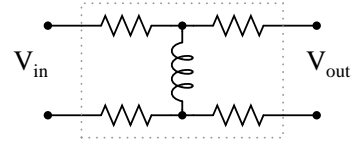
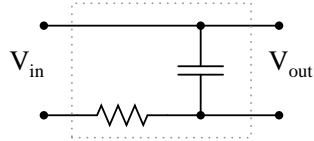

file 02098

Question 50

Identify the following filter types, and be prepared to explain your answers:

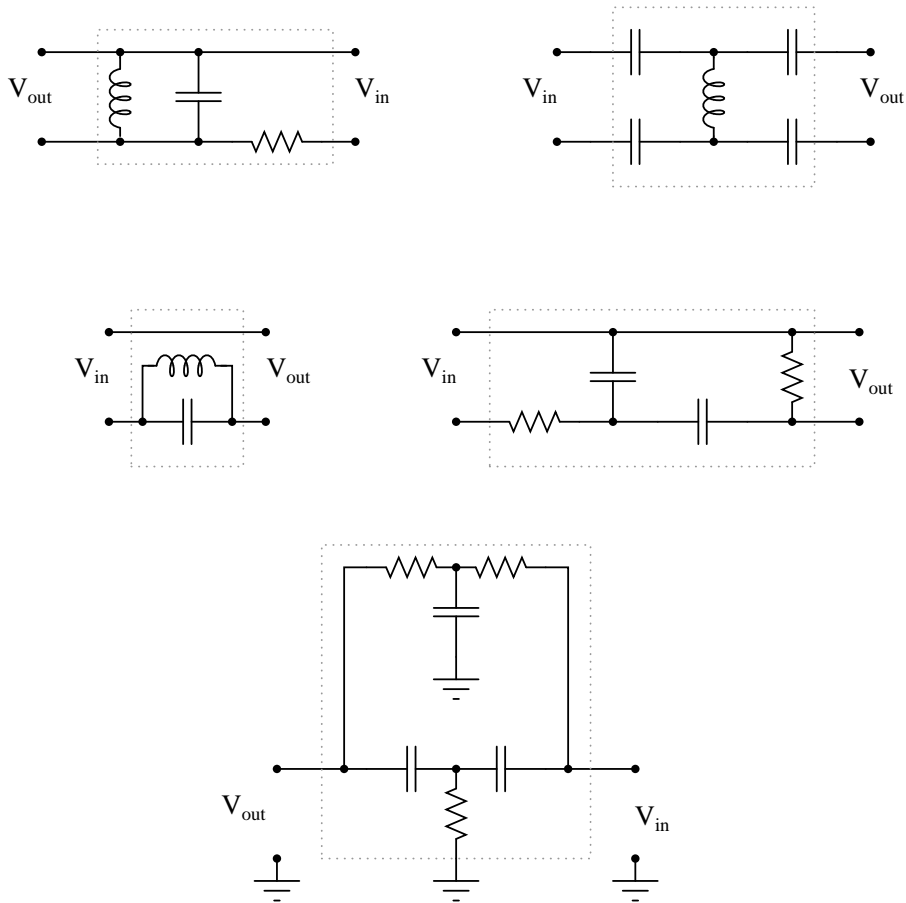

[file 00620](#)

Question 51

The *cutoff frequency*, also known as *half-power point* or *-3dB point*, of either a low-pass or a high-pass filter is fairly easy to define. But what about band-pass and band-stop filter circuits? Does the concept of a "cutoff frequency" apply to these filter types? Explain your answer.

[file 01871](#)

Question 52

A paradoxical property of resonant circuits is that they have the ability to produce quantities of voltage or current (in series and parallel circuits, respectively) exceeding that output by the power source itself. This is due to the cancellation of inductive and capacitive reactances at resonance.

Not all resonant circuits are equally effective in this regard. One way to quantify the performance of resonant circuits is to assign them a *quality factor*, or *Q* rating. This rating is very similar to the one given inductors as a measure of their reactive "purity."

Suppose we have a resonant circuit operating at its resonant frequency. How may we calculate the *Q* of this operating circuit, based on empirical measurements of voltage or current? There are *two* answers to this question: one for series circuits and one for parallel circuits.

[file 01390](#)

Question 53

The Q factor of a series inductive circuit is given by the following equation:

$$Q = \frac{X_L}{R_{series}}$$

Likewise, we know that inductive reactance may be found by the following equation:

$$X_L = 2\pi fL$$

We also know that the resonant frequency of a series LC circuit is given by this equation:

$$f_r = \frac{1}{2\pi\sqrt{LC}}$$

Through algebraic substitution, write an equation that gives the Q factor of a series resonant LC circuit exclusively in terms of L , C , and R , without reference to reactance (X) or frequency (f).

[file 01683](#)

Question 54

Calculate the resonant frequency, bandwidth, and half-power points of the following filter circuit:

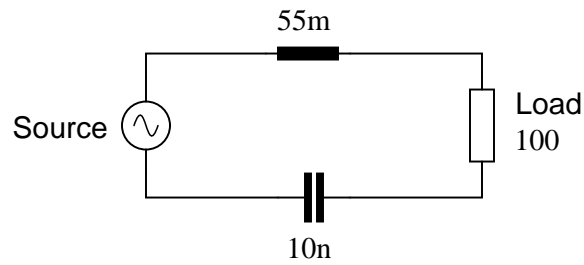

[file 01565](#)

Question 55

An interesting technology dating back at least as far as the 1940's, but which is still of interest today is *power line carrier*: the ability to communicate information as well as electrical power over power line conductors. Hard-wired electronic data communication consists of high-frequency, low voltage AC signals, while electrical power is low-frequency, high-voltage AC. For rather obvious reasons, it is important to be able to separate these two types of AC voltage quantities from entering the wrong equipment (especially the high-voltage AC power from reaching sensitive electronic communications circuitry).

Here is a simplified diagram of a power-line carrier system:

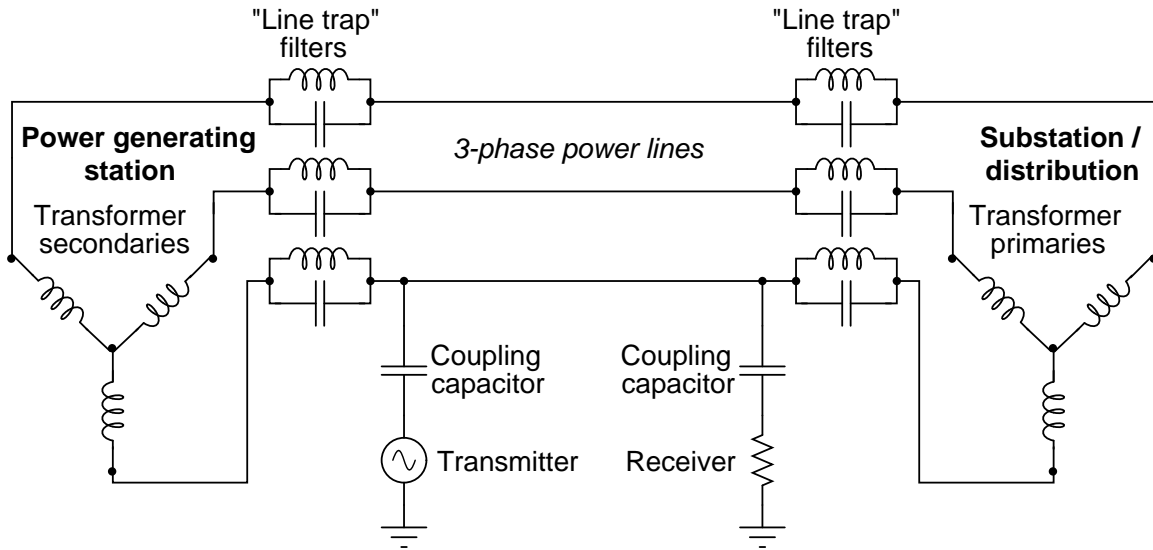

The communications transmitter is shown in simplified form as an AC voltage source, while the receiver is shown as a resistor. Though each of these components is much more complex than what is suggested by these symbols, the purpose here is to show the transmitter as a *source* of high-frequency AC, and the receiver as a *load* of high-frequency AC.

Trace the complete circuit for the high-frequency AC signal generated by the "Transmitter" in the diagram. How many power line conductors are being used in this communications circuit? Explain how the combination of "line trap" LC networks and "coupling" capacitors ensure the communications equipment never becomes exposed to high-voltage electrical power carried by the power lines, and visa-versa.

[file 01393](#)

Question 56

In this power-line carrier system, a pair of coupling capacitors connects a high-frequency "Transmitter" unit to two power line conductors, and a similar pair of coupling capacitors connects a "Receiver" unit to the same two conductors:

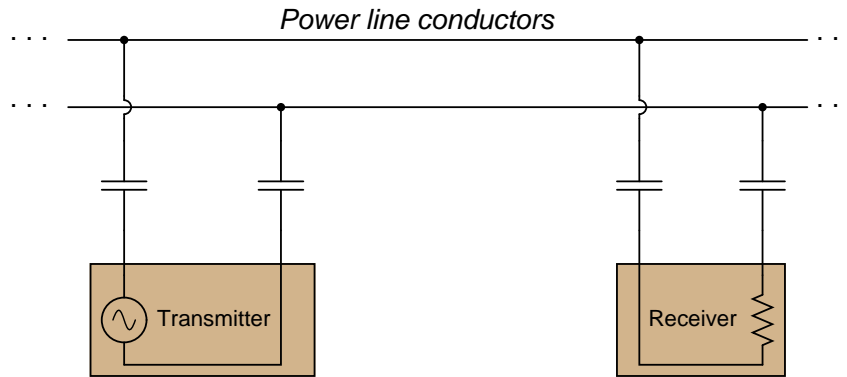

While coupling capacitors alone are adequate to perform the necessary filtering function needed by the communications equipment (to prevent damaged from the high-voltage electrical power also carried by the lines), that signal coupling may be made more efficient by the introduction of two *line tuning* units:

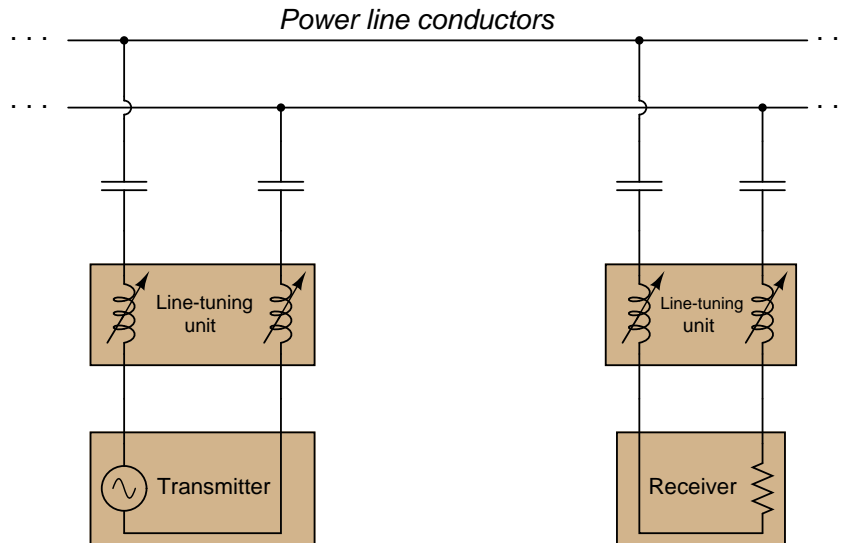

Explain why the addition of more components (in series, no less!) provides a better "connection" between the high-frequency Transmitter and Receiver units than coupling capacitors alone. Hint: the operating frequency of the communications equipment is fixed, or at least variable only over a narrow range.

file 01394

Question 57

Shown here are two frequency response plots (known as *Bode plots*) for a pair of series resonant circuits. Each circuit has the same inductance and capacitance values, but different resistance values. The "output" is voltage measured across the resistor of each circuit:

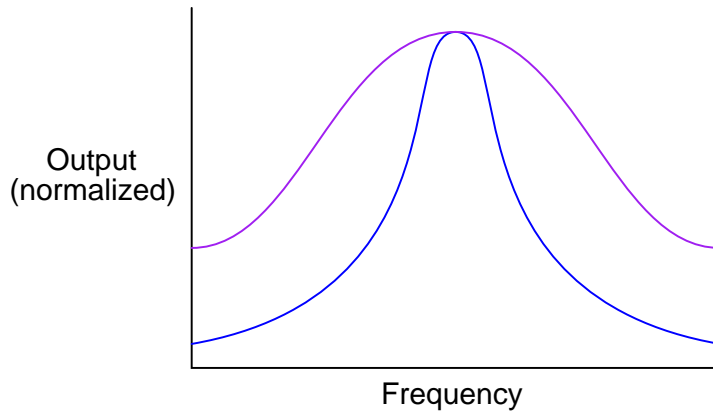
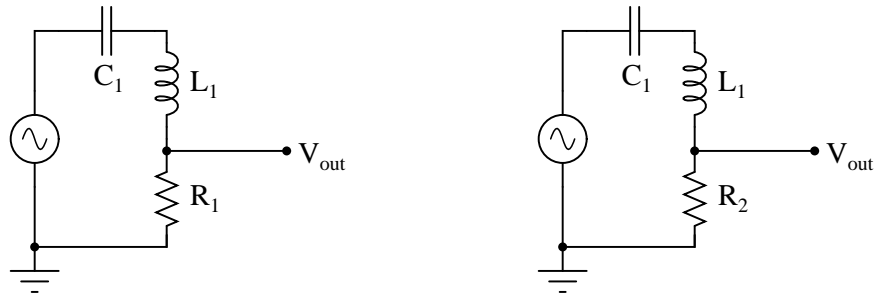

Which one of these plots represents the response of the circuit with the greatest Q , or *quality factor*?
[file 01391](#)

Question 58

There is a direct, mathematical relationship between bandwidth, resonant frequency, and Q in a resonant filter circuit, but imagine for a moment that you forgot exactly what that formula was. You think it must be one of these two, but you are not sure which:

$$\text{Bandwidth} = \frac{Q}{f_r} \quad (\text{or possibly}) \quad \text{Bandwidth} = \frac{f_r}{Q}$$

Based on your conceptual knowledge of how a circuit's quality factor affects its frequency response, determine which of these formulae must be incorrect. In other words, *demonstrate* which of these must be correct rather than simply looking up the correct formula in a reference book.

[file 01870](#)

Question 59

Suppose you have a 110 mH inductor, and wish to combine it with a capacitor to form a band-stop filter with a "notch" frequency of 1 kHz. Draw a schematic diagram showing what the circuit would look like (complete with input and output terminals) and calculate the necessary capacitor size to do this, showing the equation you used to solve for this value. Also, calculate the bandwidth of this notch filter, assuming the inductor has an internal resistance of 20 ohms, and that there is negligible resistance in the rest of the circuit.

[file 01872](#)

Question 60

Shown here are two frequency response plots (known as *Bode plots*) for a pair of series resonant circuits with the same resonant frequency. The "output" is voltage measured across the resistor of each circuit:

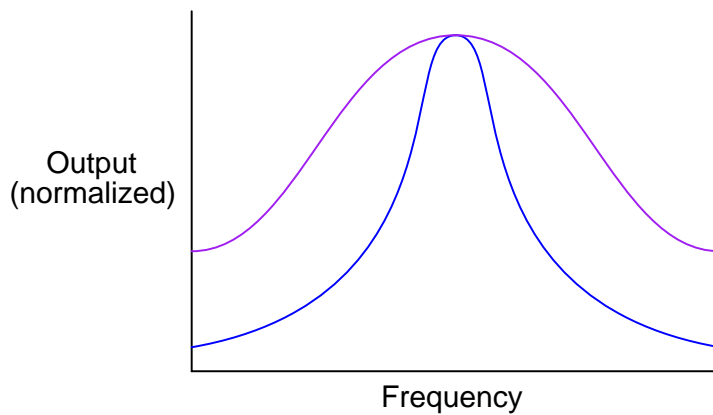
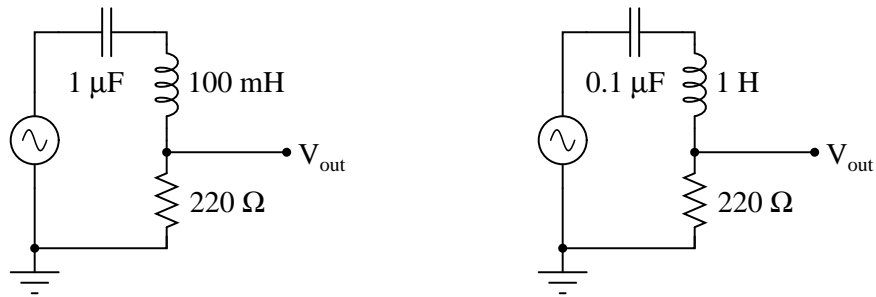

Determine which plot is associated with which circuit, and explain your answer.

[file 01682](#)

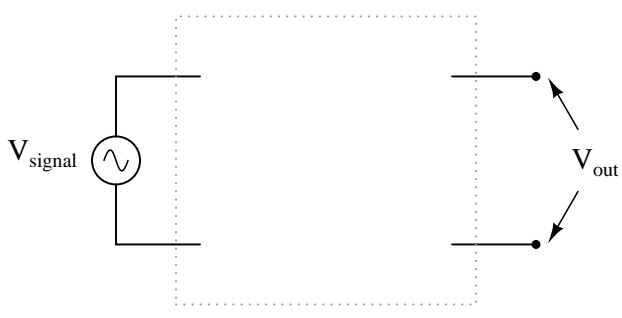
Competency: Passive RC filter circuit design	Version:									
Description										
Design and build an RC filter circuit, either high pass or low pass, with the specified cutoff frequency.										
Given conditions										
<i>(instructor checks one)</i>										
$f_{-3dB} =$	High-pass <input type="checkbox"/> Low-pass <input type="checkbox"/>									
Parameters										
	<table style="margin-left: auto; margin-right: auto;"> <thead> <tr> <th style="padding: 5px;"></th> <th style="padding: 5px;">Predicted</th> <th style="padding: 5px;">Measured</th> </tr> </thead> <tbody> <tr> <td style="padding: 5px;">f_{-3dB}</td> <td style="border: 1px solid black; width: 80px; height: 25px;"></td> <td style="border: 1px solid black; width: 80px; height: 25px;"></td> </tr> <tr> <td style="padding: 5px;">θ_{-3dB}</td> <td style="border: 1px solid black; width: 80px; height: 25px;"></td> <td style="border: 1px solid black; width: 80px; height: 25px;"></td> </tr> </tbody> </table>		Predicted	Measured	f_{-3dB}			θ_{-3dB}		
	Predicted	Measured								
f_{-3dB}										
θ_{-3dB}										
Schematic										
										

file 02095

Competency: Measuring inductance by series resonance Version:	
Schematic	
Given conditions	
$R_1 =$	$C_1 =$
Parameters	
f_{resonant}	Measured <input style="width: 100px; height: 20px;" type="text"/>
Inferred from f_{resonant}	Measured with LCR meter
L_x <input style="width: 100px; height: 20px;" type="text"/>	<input style="width: 100px; height: 20px;" type="text"/>
Calculations	

file 01691

Competency: Passive resonant filter circuit	Version:		
Schematic			
Given conditions			
$V_{\text{signal}} =$	$C_1 =$	$L_1 =$	$R_{\text{load}} =$
Parameters			
	Predicted	Measured	
Filter type (hp, lp, bp, bs)			
f_{resonant}			
Calculations			
Fault analysis			
Suppose component <input style="width: 40px; height: 20px;" type="text"/> fails		<input type="checkbox"/> open	<input type="checkbox"/> other _____
<i>What will happen in the circuit?</i>		<input type="checkbox"/> shorted	

file 01658

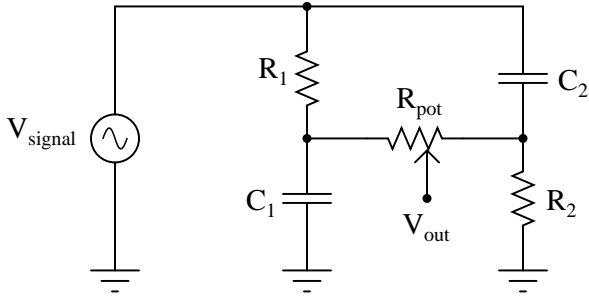
Competency: Variable phase shift bridge circuit		Version:				
Schematic						
						
Given conditions						
$V_{\text{signal}} =$ $f_{\text{signal}} =$	$R_1 = R_2 =$ $C_1 = C_2 =$ $R_{\text{pot}} =$	<p style="text-align: center;"><i>Recommendations</i></p> $R \approx \frac{1}{2\pi f C}$ $R_{\text{pot}} \gg R_1, R_2$				
Parameters						
$\theta_{V_{\text{out}}}$	<table border="1" style="margin: auto;"> <tr> <td style="padding: 2px;">Predicted</td> <td style="padding: 2px;">Measured</td> </tr> <tr> <td style="width: 60px; height: 25px;"></td> <td style="width: 60px; height: 25px;"></td> </tr> </table>	Predicted	Measured			<i>Potentiometer at full-left position</i>
Predicted	Measured					
$\theta_{V_{\text{out}}}$	<table border="1" style="margin: auto;"> <tr> <td style="padding: 2px;">Predicted</td> <td style="padding: 2px;">Measured</td> </tr> <tr> <td style="width: 60px; height: 25px;"></td> <td style="width: 60px; height: 25px;"></td> </tr> </table>	Predicted	Measured			<i>Potentiometer at full-right position</i>
Predicted	Measured					
V_{out}	<table border="1" style="margin: auto;"> <tr> <td style="padding: 2px;">Predicted</td> <td style="padding: 2px;">Measured</td> </tr> <tr> <td style="width: 60px; height: 25px;"></td> <td style="width: 60px; height: 25px;"></td> </tr> </table>	Predicted	Measured			<i>Potentiometer at full-left position</i>
Predicted	Measured					
V_{out}	<table border="1" style="margin: auto;"> <tr> <td style="padding: 2px;">Predicted</td> <td style="padding: 2px;">Measured</td> </tr> <tr> <td style="width: 60px; height: 25px;"></td> <td style="width: 60px; height: 25px;"></td> </tr> </table>	Predicted	Measured			<i>Potentiometer at full-right position</i>
Predicted	Measured					

file 03468

Question 66

NAME: _____ **Troubleshooting Grading Criteria**

You will receive the highest score for which *all* criteria are met.

100 % (*Must meet or exceed all criteria listed*)

- A. Absolutely flawless procedure
- B. No unnecessary actions or measurements taken

90 % (*Must meet or exceed these criteria in addition to all criteria for 85% and below*)

- A. No reversals in procedure (i.e. changing mind without sufficient evidence)
- B. Every single action, measurement, and relevant observation properly documented

80 % (*Must meet or exceed these criteria in addition to all criteria for 75% and below*)

- A. No more than one unnecessary action or measurement
- B. No false conclusions or conceptual errors
- C. No missing conclusions (i.e. at least one documented conclusion for action / measurement / observation)

70 % (*Must meet or exceed these criteria in addition to all criteria for 65%*)

- A. No more than one false conclusion or conceptual error
- B. No more than one conclusion missing (i.e. an action, measurement, or relevant observation without a corresponding conclusion)

65 % (*Must meet or exceed these criteria in addition to all criteria for 60%*)

- A. No more than two false conclusions or conceptual errors
- B. No more than two unnecessary actions or measurements
- C. No more than one undocumented action, measurement, or relevant observation
- D. Proper use of all test equipment

60 % (*Must meet or exceed these criteria*)

- A. Fault accurately identified
- B. Safe procedures used at all times

50 % (*Only applicable where students performed significant development/design work – i.e. not a proven circuit provided with all component values*)

- A. Working prototype circuit built and demonstrated

0 % (*If any of the following conditions are true*)

- A. Unsafe procedure(s) used at any point

file 03932

Question 67

Stereo (two-speaker) headphones typically use a plug with three contact points to connect the speakers to the audio amplifier. The three contact points are designated as "tip," "ring," and "sleeve" for reasons that are obvious upon inspection, and as such the plug is commonly referred to as a "TRS" plug. Both speakers in the headphone unit share a common connection (at the "sleeve" contact), with the "tip" and "ring" contacts providing connection to left and right speakers, respectively:

Typical stereo headphone plug

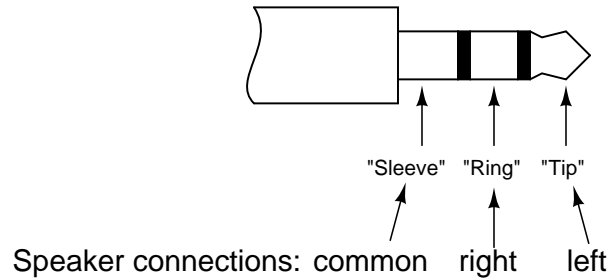

Draw a picture showing how connections would be made to the plug's contact points to form this circuit:

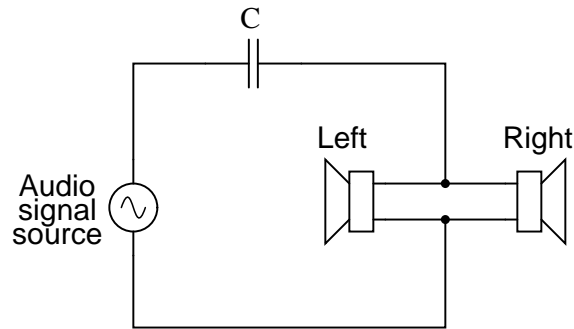

file 00752

Question 68

Stereo (two-speaker) headphones typically use a plug with three contact points to connect the speakers to the audio amplifier. The three contact points are designated as "tip," "ring," and "sleeve" for reasons that are obvious upon inspection, and as such the plug is commonly referred to as a "TRS" plug. Both speakers in the headphone unit share a common connection (at the "sleeve" contact), with the "tip" and "ring" contacts providing connection to left and right speakers, respectively:

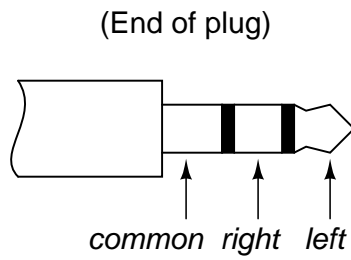

Draw a picture showing how connections would be made to the plug's contact points to form this circuit:

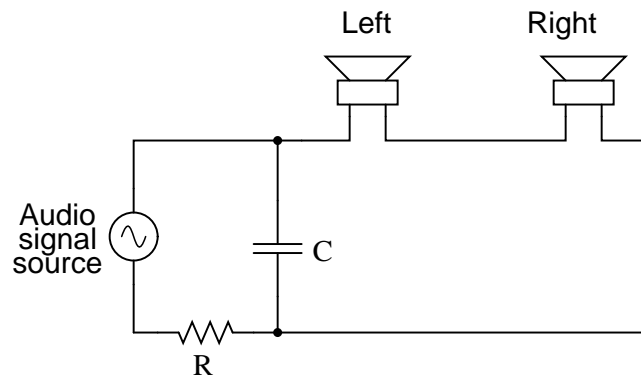

file 00753

Question 69

Complex number arithmetic makes possible the analysis of AC circuits using (almost) the exact same Laws that were learned for DC circuit analysis. The only bad part about this is that doing complex-number arithmetic by hand can be very tedious. Some calculators, though, are able to add, subtract, multiply, divide, and invert complex quantities as easy as they do scalar quantities, making this method of AC circuit analysis relatively easy.

This question is really a series of practice problems in complex number arithmetic, the purpose being to give you lots of practice using the complex number facilities of your calculator (or to give you a *lot* of practice doing trigonometry calculations, if your calculator does not have the ability to manipulate complex numbers!).

Addition and subtraction:

$$(5 + j6) + (2 - j1) =$$

$$(10 - j8) + (4 - j3) =$$

$$(-3 + j0) + (9 - j12) =$$

$$(3 + j5) - (0 - j9) =$$

$$(25 - j84) - (4 - j3) =$$

$$(-1500 + j40) + (299 - j128) =$$

$$(25\angle 15^\circ) + (10\angle 74^\circ) =$$

$$(1000\angle 43^\circ) + (1200\angle -20^\circ) =$$

$$(522\angle 71^\circ) - (85\angle 30^\circ) =$$

Multiplication and division:

$$(25\angle 15^\circ) \times (12\angle 10^\circ) =$$

$$(1\angle 25^\circ) \times (500\angle -30^\circ) =$$

$$(522\angle 71^\circ) \times (33\angle 9^\circ) =$$

$$\frac{10\angle -80^\circ}{1\angle 0^\circ} =$$

$$\frac{25\angle 120^\circ}{3.5\angle -55^\circ} =$$

$$\frac{-66\angle 67^\circ}{8\angle -42^\circ} =$$

$$(3 + j5) \times (2 - j1) =$$

$$(10 - j8) \times (4 - j3) =$$

$$\frac{(3+j4)}{(12-j2)} =$$

Reciprocation:

$$\frac{1}{(15\angle 60^\circ)} =$$

$$\frac{1}{(750\angle -38^\circ)} =$$

$$\frac{1}{(10+j3)} =$$

$$\frac{1}{\frac{1}{15\angle 45^\circ} + \frac{1}{92\angle -25^\circ}} =$$

$$\frac{1}{\frac{1}{1200\angle 73^\circ} + \frac{1}{574\angle 21^\circ}} =$$

$$\frac{1}{\frac{1}{23k\angle -67^\circ} + \frac{1}{10k\angle -81^\circ}} =$$

$$\frac{1}{\frac{1}{110\angle -34^\circ} + \frac{1}{80\angle 19^\circ} + \frac{1}{70\angle 10^\circ}} =$$

$$\frac{1}{\frac{1}{89k\angle -5^\circ} + \frac{1}{15k\angle 33^\circ} + \frac{1}{9.35k\angle 45^\circ}} =$$

$$\frac{1}{\frac{1}{512\angle 34^\circ} + \frac{1}{1k\angle -25^\circ} + \frac{1}{942\angle -20^\circ} + \frac{1}{2.2k\angle 44^\circ}} =$$

file 00860

Question 70

Electrical engineers often represent impedances in rectangular form for the sake of algebraic manipulation: to be able to construct and manipulate equations involving impedance, in terms of the components' fundamental values (resistors in ohms, capacitors in farads, and inductors in henrys).

For example, the impedance of a series-connected resistor (R) and inductor (L) would be represented as follows, with angular velocity (ω) being equal to $2\pi f$:

$$\mathbf{Z} = R + j\omega L$$

Using the same algebraic notation, represent each of the following complex quantities:

- Impedance of a single capacitor (C) =
- Impedance of a series resistor-capacitor (R, C) network =
- Admittance of a parallel inductor-resistor (L, R) network =
- Admittance of a parallel resistor-capacitor (R, C) network =

[file 02117](#)

Question 71

Convert this series-parallel combination circuit into an equivalent simple-parallel circuit (all components connected in parallel with each other, with nothing in series), and also calculate the circuit's total impedance:

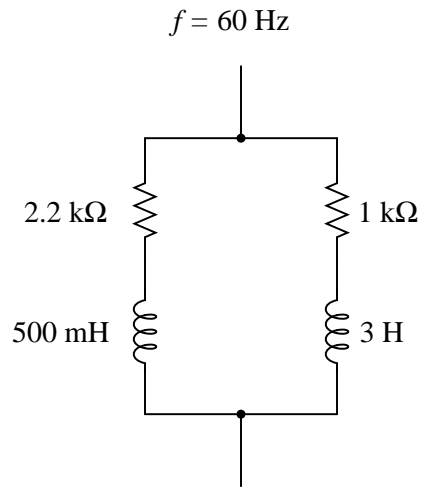

[file 00857](#)

Question 72

Calculate the "output" voltage (V_{out}) for this AC circuit, expressed as a complex quantity in polar notation:

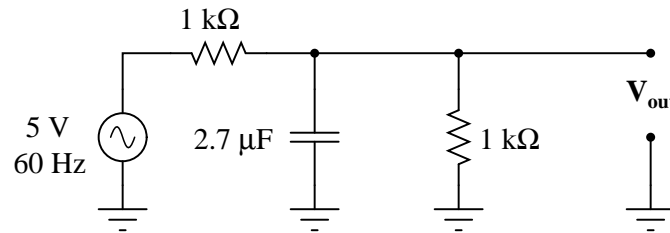

[file 03279](#)

Question 73

It is not uncommon to see impedances represented in AC circuits as boxes, rather than as combinations of R, L, and/or C. This is simply a convenient way to represent what may be complex sub-networks of components in a larger AC circuit:

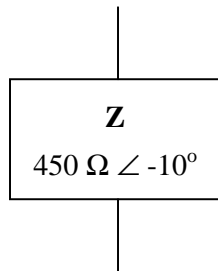

We know that any given impedance may be represented by a simple, two-component circuit: either a resistor and a reactive component connected in series, or a resistor and a reactive component connected in parallel. Assuming a circuit frequency of 50 Hz, determine what combination of series-connected components will be equivalent to this "box" impedance, and also what combination of parallel-connected components will be equivalent to this "box" impedance.

[file 03295](#)

Question 74

It is not uncommon to see impedances represented in AC circuits as boxes, rather than as combinations of R, L, and/or C. This is simply a convenient way to represent what may be complex sub-networks of components in a larger AC circuit:

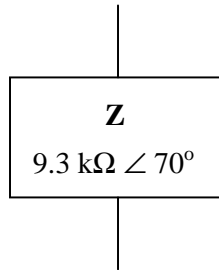

We know that any given impedance may be represented by a simple, two-component circuit: either a resistor and a reactive component connected in series, or a resistor and a reactive component connected in parallel. Assuming a circuit frequency of 2 kHz, determine what combination of series-connected components will be equivalent to this "box" impedance, and also what combination of parallel-connected components will be equivalent to this "box" impedance.

[file 03296](#)

Question 75

Calculate the total impedance of this series network of impedances, in complex form:

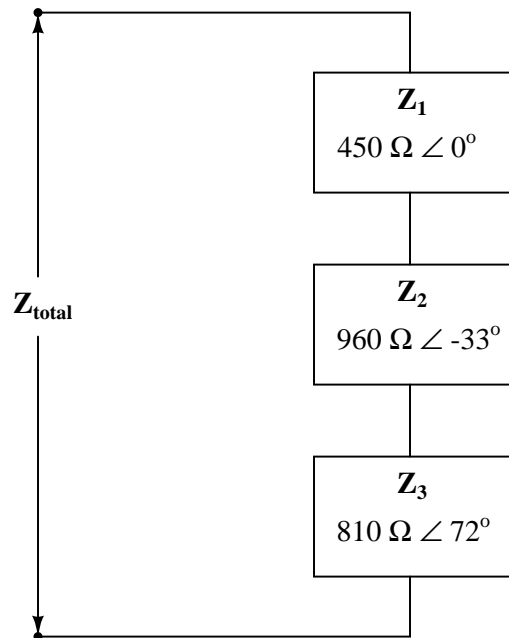

[file 00636](#)

Question 76

Calculate the total impedance of this parallel network of impedances, in complex form:

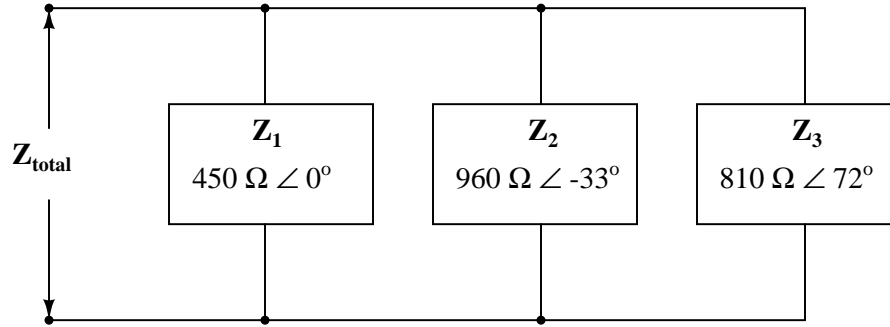

file 00622

Question 77

Calculate the total impedance of this series-parallel network of impedances, in complex form:

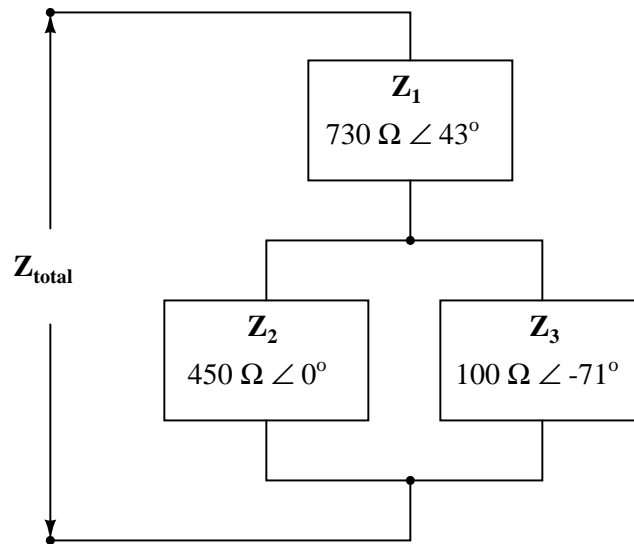

file 01866

Question 78

Complete the table of values for this circuit, representing all quantities in complex-number form:

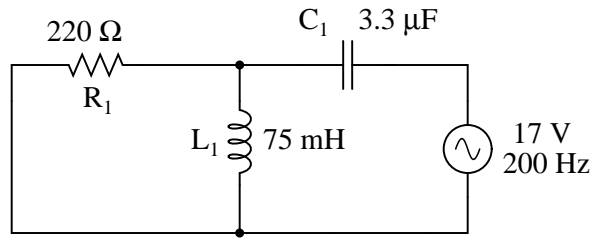

	R_1	L_1	C_1	Total
V				
I				
Z				

[file 01867](#)

Question 79

Complete the table of values for this circuit, representing all quantities in complex-number form:

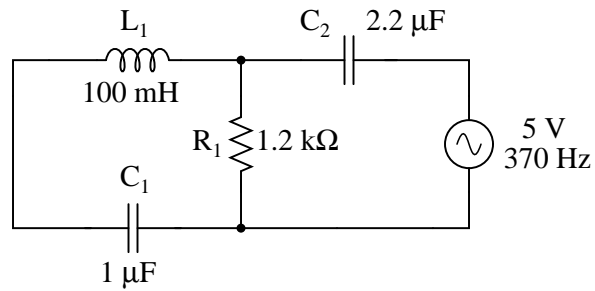

	R_1	L_1	C_1	C_2	Total
V					
I					
Z					

[file 01868](#)

Question 80

Calculate all voltage drops in this circuit, expressing your answers in complex (polar) form:

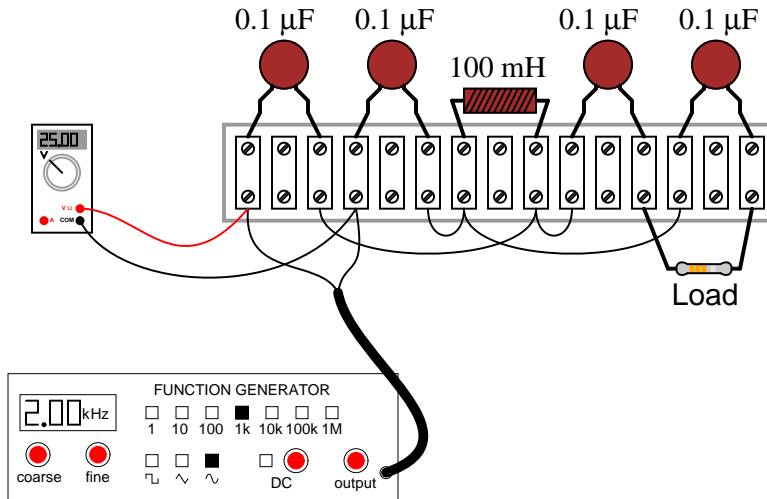

The load resistor's color code is as follows:

Brown, Black, Black, Brown, Violet

Assume the resistor's error is 0%. That is, its resistance value is precisely equal to what the "digit" and "multiplier" color bands declare. The signal generator's output is 25 volts RMS, at a frequency of 2 kHz.

Challenge question: what practical function does this circuit perform?

file 01071

Question 81

Suppose we have two equivalent LR networks, one series and one parallel, such that they have the exact same total impedance ($\mathbf{Z}_{\text{total}}$):

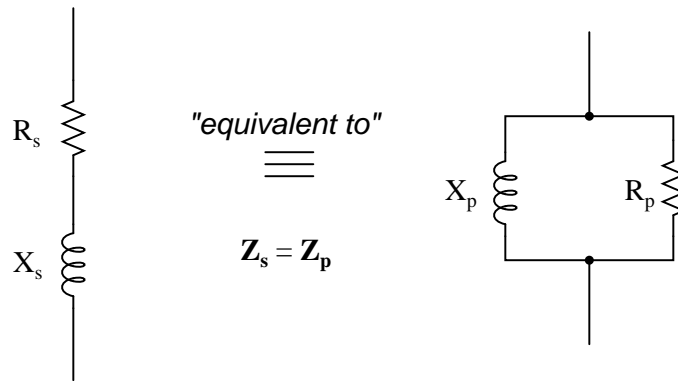

We may write an equation for the impedance of each network in rectangular form, like this:

$$\mathbf{Z}_s = R_s + jX_s \quad (\text{series network})$$

$$\mathbf{Z}_p = \frac{1}{\frac{1}{R_p} - j\frac{1}{X_p}} \quad (\text{parallel network})$$

Since we are told these two networks are equivalent to one another, with equal impedances, these two expressions in rectangular form must also be equal to each other:

$$R_s + jX_s = \frac{1}{\frac{1}{R_p} - j\frac{1}{X_p}}$$

Algebraically reduce this equation to its simplest form, showing how R_s , R_p , X_s , and X_p relate.

Challenge question: combine the result of that simplification with the equations solving for *scalar* impedance of series and parallel networks ($Z_s^2 = R_s^2 + X_s^2$ for series and $Z_p^2 = \frac{1}{\frac{1}{R_p^2} + \frac{1}{X_p^2}}$ for parallel) to prove the following transformative equations, highly useful for "translating" a series network into a parallel network and visa-versa:

$$Z^2 = R_p R_s$$

$$Z^2 = X_p X_s$$

[file 03291](#)

Question 82

An AC bridge circuit commonly used to make precision measurements of inductors is the *Maxwell-Wien* bridge. It uses a combination of standard resistors and capacitors to "balance out" the inductor of unknown value in the opposite arm of the bridge:

The Maxwell-Wien bridge

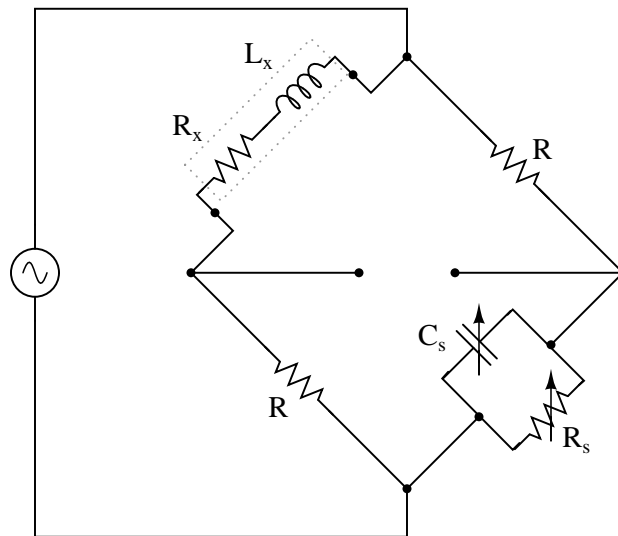

Suppose this bridge circuit balances when C_s is adjusted to 120 nF and R_s is adjusted to 14.25 k Ω . If the source frequency is 400 Hz, and the two fixed-value resistors are 1 k Ω each, calculate the inductance (L_x) and resistance (R_x) of the inductor being tested.

file 00862

Mathematical analysis of the Maxwell-Wien bridge is as follows:

The Maxwell-Wien bridge

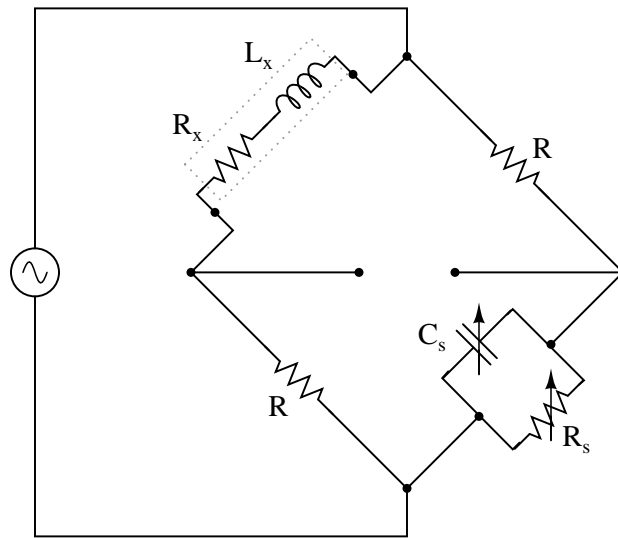

$$\mathbf{Z}_x = R_x + j\omega L_x \quad \text{Impedance of unknown inductance/resistance arm}$$

$$\mathbf{Z}_s = \frac{1}{\frac{1}{R_s} + \frac{1}{-j\omega C_s}} \quad \text{Impedance of standard capacitance/resistance arm}$$

$$\mathbf{Y}_s = \frac{1}{R_s} + j\omega C_s \quad \text{Admittance of standard capacitance/resistance arm}$$

$$\frac{\mathbf{Z}_x}{\mathbf{Z}_R} = \frac{\mathbf{Z}_R}{\mathbf{Z}_s} \quad \text{or} \quad \frac{\mathbf{Z}_x}{\mathbf{Z}_R} = \mathbf{Z}_R \mathbf{Y}_s \quad \text{Bridge balance equation}$$

$$\mathbf{Z}_x = R^2 \mathbf{Y}_s$$

$$R_x + j\omega L_x = R^2 \left(\frac{1}{R_s} + j\omega C_s \right)$$

$$R_x + j\omega L_x = \frac{R^2}{R_s} + j\omega R^2 C_s$$

Separating real and imaginary terms . . .

$$R_x = \frac{R^2}{R_s} \quad (\text{Real})$$

$$j\omega L_x = j\omega R^2 C_s \quad (\text{Imaginary})$$

$$L_x = R^2 C_s$$

Note that neither of the two equations solving for unknown quantities ($R_x = \frac{R^2}{R_s}$ and $L_x = R^2 C_s$) contain the variable ω . What does this indicate about the Maxwell-Wien bridge?

[file 01861](#)

Question 84

The Q , or *quality factor*, of an inductor circuit is defined by the following equation, where X_s is the series inductive reactance and R_s is the series resistance:

$$Q = \frac{X_s}{R_s}$$

We also know that we may convert between series and parallel equivalent AC networks with the following conversion equations:

$$R_s R_p = Z^2 \qquad X_s X_p = Z^2$$

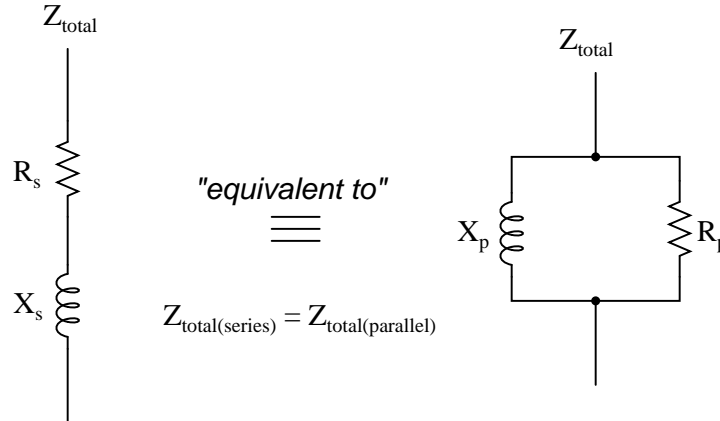

Series and parallel LR networks, if truly equivalent, should share the same Q factor as well as sharing the same impedance. Develop an equation that solves for the Q factor of a *parallel* LR circuit.

[file 02096](#)

Question 85

Why are polarity marks (+ and -) shown at the terminals of the components in this AC network?

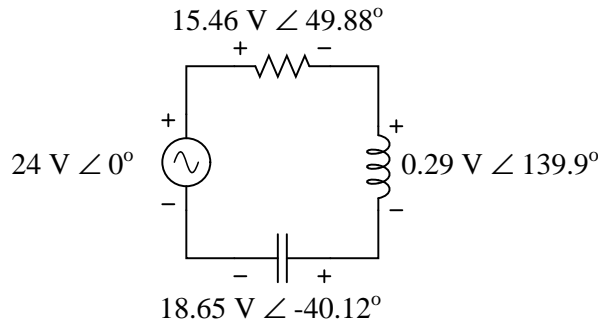

Are these polarity markings really necessary? Do they make any sense at all, given the fact that AC by its very nature has no fixed polarity (because polarity alternates over time)? Explain your answer.

[file 01054](#)

Question 86

What kind of filtering action (high-pass, low-pass, band-pass, band-stop) does this resonant circuit provide?

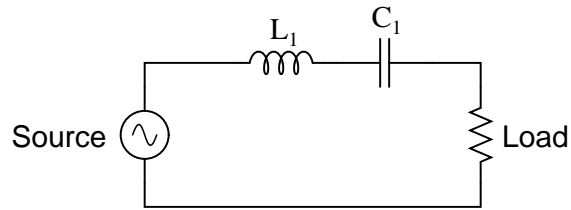

[file 01392](#)

Question 87

What kind of filtering action (high-pass, low-pass, band-pass, band-stop) does this resonant circuit provide?

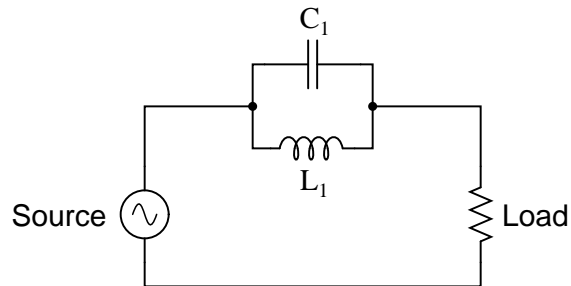

[file 02570](#)

Question 88

Suppose a few turns of wire within the inductor in this filter circuit suddenly became short-circuited, so that the inductor effectively has fewer turns of wire than it did before:

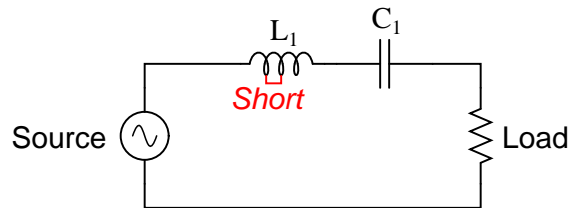

What sort of effect would this fault have on the filtering action of this circuit?

[file 03505](#)

Question 89

A *white noise* source is a special type of AC signal voltage source which outputs a broad band of frequencies ("noise") with a constant amplitude across its rated range. Determine what the display of a spectrum analyzer would show if directly connected to a white noise source, and also if connected to a low-pass filter which is in turn connected to a white noise source:

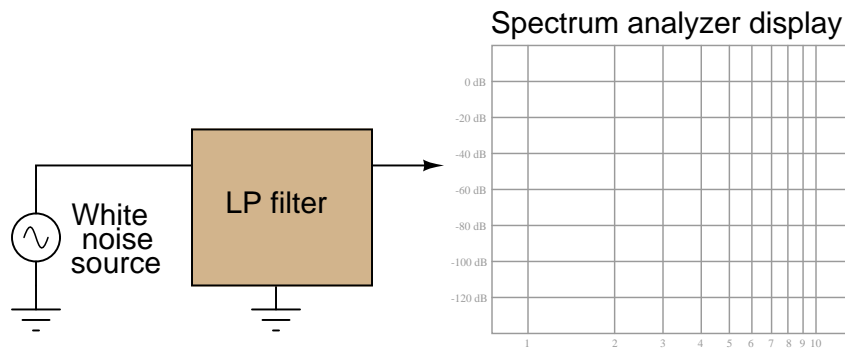
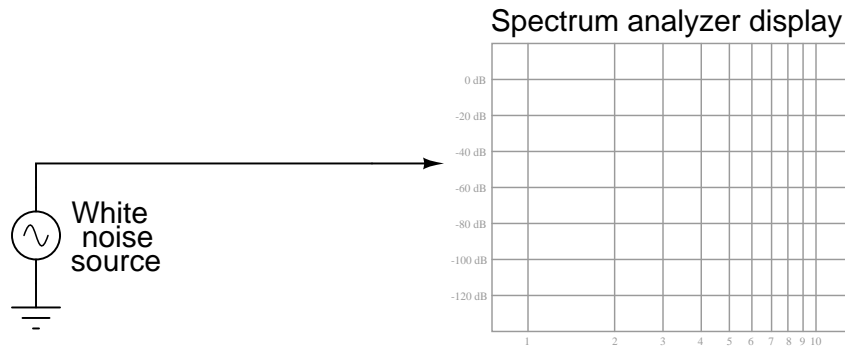

[file 03621](#)

Question 90

Examine the following schematic diagram for an audio tone control circuit:

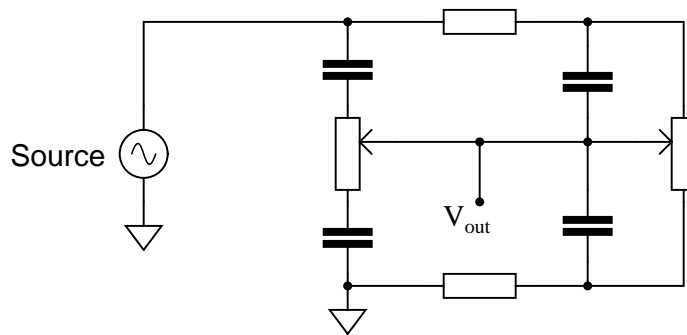

Determine which potentiometer controls the bass (low frequency) tones and which controls the treble (high frequency) tones, and explain how you made those determinations.

[file 03506](#)

Question 91

Examine the following audio tone control circuit, used to control the balance of bass and treble heard at the headphones from an audio source such as a radio or CD player:

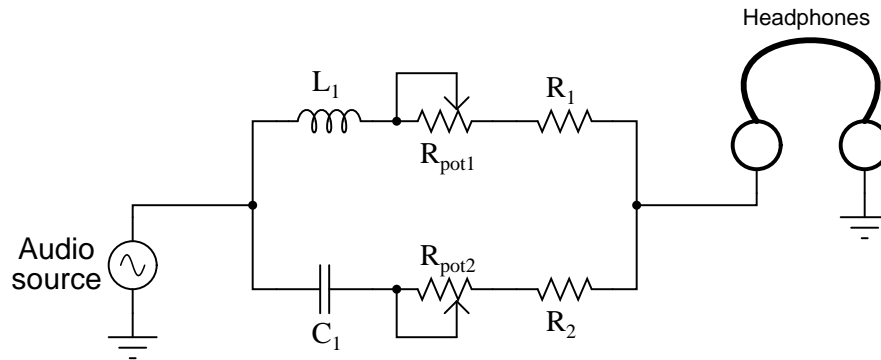

Suppose that after working just fine for quite a long while, suddenly no more bass tones were heard through the headphones. Identify at least two component or wiring faults that could cause this to happen.
[file 03507](#)

Question 92

Suppose that the following audio tone control circuit has a problem: the second potentiometer (R_{pot2}) seems to act more like a plain volume control than a tone control. Instead of adjusting the amount of treble heard at the headphones, it seems to adjust the volume of bass and treble tones alike:

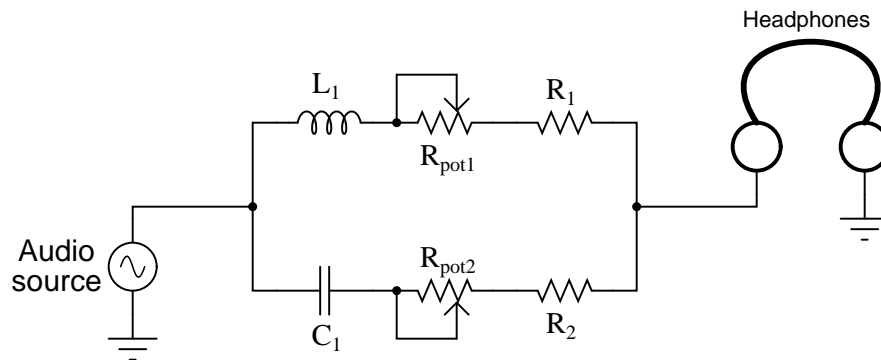

What do you think might be wrong with this circuit? Assuming it has been correctly designed and was working well for some time, what component or wire failure could possibly account for this behavior?
[file 03508](#)

Question 93

Suppose that the following audio tone control circuit has a problem: the first potentiometer (R_{pot1}) seems to act more like a plain volume control than a tone control. Instead of adjusting the amount of bass heard at the headphones, it seems to adjust the volume of bass and treble tones alike:

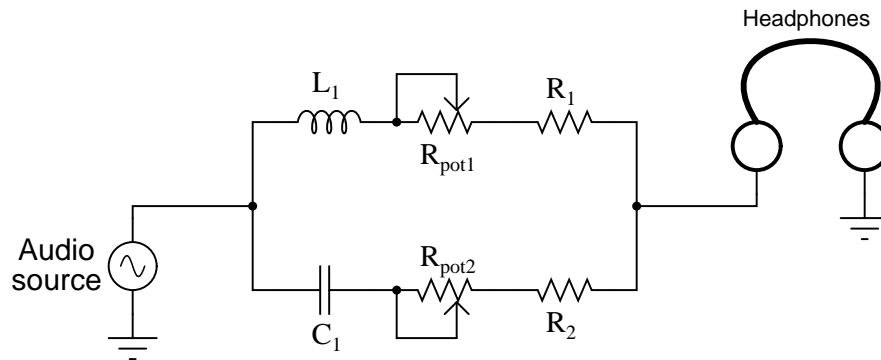

What do you think might be wrong with this circuit? Assuming it has been correctly designed and was working well for some time, what component or wire failure could possibly account for this behavior?

[file 03509](#)

Question 94

A *helical resonator* is a special type of band-pass filter commonly used in VHF and UHF radio receiver circuitry. Such a device is made up of multiple metal cavities, each containing a helix (coil) of wire connected to the cavity at one end and free at the other. Slots cut between the cavities permits coupling between the coils, with the input at one extreme end and the output at the other:

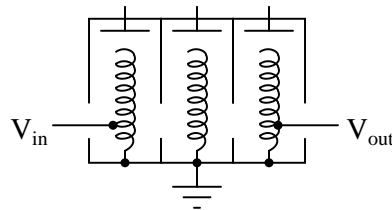

The above illustration shows a three-stage helical resonator, with adjustable metal plates at the top of each helix for tuning. Draw a schematic representation of this resonator, and explain where the capacitance comes from that allows each of the coils to form a resonant circuit.

[file 03511](#)

Answers

Answer 1

$$\mathbf{Z}_{\text{total}} = 13 \Omega \angle -90^\circ$$

Follow-up question: does this circuit "appear" to be inductive or capacitive from the source's point of view?

Answer 2

$$Z_{\text{total}} = \sqrt{R^2 + (X_L - X_C)^2}$$

Answer 3

$$Y_{\text{total}} = \sqrt{G^2 + (B_L - B_C)^2}$$

Answer 4

$$\mathbf{Z}_{\text{total}} = 8.911 \text{ k}\Omega \angle 26.98^\circ$$

Answer 5

Overall, the first (series) circuit's behavior is *inductive*. The second (parallel) circuit's behavior, though, is *capacitive*.

Follow-up question: which component "dominates" the behavior of a series LC circuit, the one with the least reactance or the one with the greatest reactance? Which component "dominates" the behavior of a parallel LC circuit, the one with the least reactance or the one with the greatest reactance?

Answer 6

$$R_{\text{parallel}} = 13.16 \Omega$$

$$L_{\text{parallel}} = 51.75 \text{ mH}$$

Challenge question: in the parallel LR circuit, the resistor will dissipate a lot of energy in the form of heat. Does this mean that the electric motor, which is electrically equivalent to the LR network, will dissipate the same amount of heat? Explain why or why not.

Answer 7

A 1132.1 Ω resistor connected in series with a 269.6 nF capacitor would suffice.

Answer 8

I'll let you figure out how to turn $\frac{R}{Z} = \frac{G}{Y}$ into $R_{\text{series}}R_{\text{parallel}} = Z_{\text{total}}^2$ on your own!

As for the reactance relation equation, here it is:

$$X_{\text{series}}X_{\text{parallel}} = Z_{\text{total}}^2$$

Answer 9

$$R = 150 \Omega$$

$$X_C = 200 \Omega$$

Follow-up question: explain how you could check your conversion calculations, to ensure both networks are truly equivalent to each other.

Answer 10

$$R_{parallel} = 2092 \Omega$$

$$L_{parallel} = 1.325 \text{ H}$$

$$\mathbf{Z}_{total} = 1772 \Omega \angle 32.14^\circ$$

Answer 11

$$R_{series} = 454.8 \Omega$$

$$C_{series} = 3.3 \mu\text{F}$$

$$\mathbf{Z}_{total} = 1066 \Omega \angle -64.75^\circ$$

Answer 12

$$\mathbf{Z}_{total} = 1.18 \text{ k}\Omega \angle 50.54^\circ$$

If connected in parallel: $R = 1.857 \text{ k}\Omega$; $L = 243.3 \text{ mH}$.

Hint: if you are having difficulty figuring out where to start in answering this question, consider the fact that these two circuits, if equivalent in total impedance, will draw the exact same amount of current from a common AC source at 1 kHz.

Answer 13

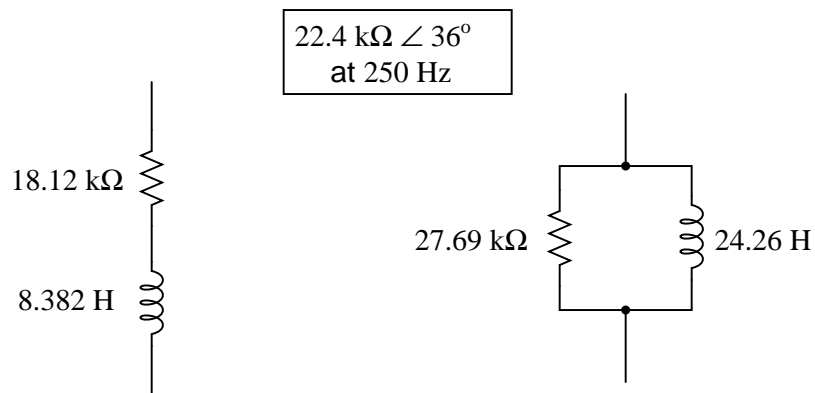

Answer 14

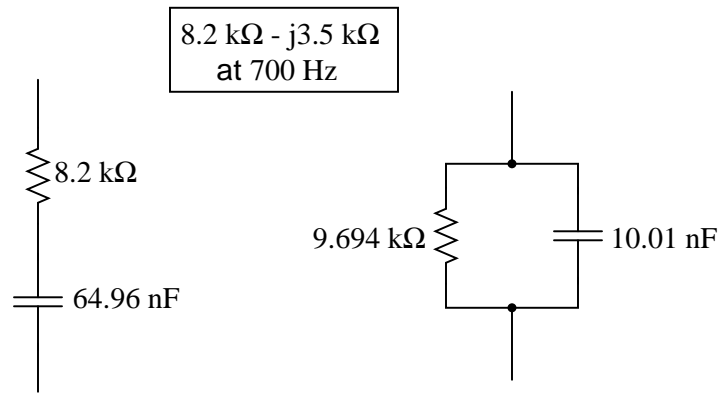

Answer 15

Polar form relates much better to the voltmeter's display of 5 volts.

Follow-up question: how would you represent the total voltage in this circuit in rectangular form, given the other two voltmeter readings?

Answer 16

$$I = 545.45 \mu\text{A} \angle 21^\circ$$

$$I = 509.23 \mu\text{A} + j195.47 \mu\text{A}$$

Follow-up question: which of these two forms is more meaningful when comparing against the indication of an AC ammeter? Explain why.

Answer 17

Equivalent series resistance and reactances:

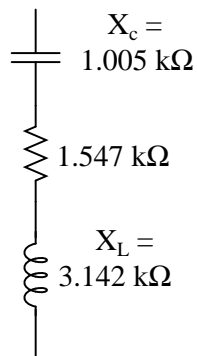

$$Z_{total} = 2.638 \text{ k}\Omega$$

Answer 18

Equivalent parallel resistance and reactances:

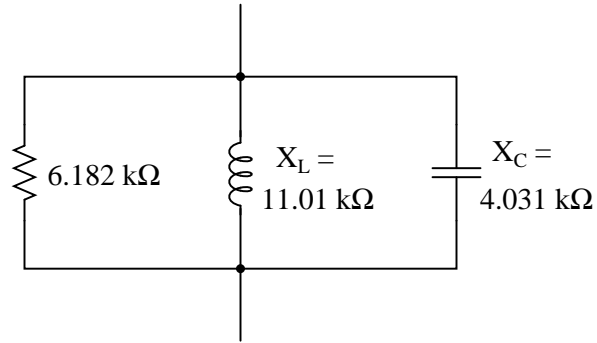

$$Z_{total} = 4.433 \text{ k}\Omega$$

Answer 19

$$V_{AB} = 10.491 \text{ volts}$$

Answer 20

$$I_{LR} = 3.290 \text{ mA}$$

Answer 21

- $f = 1 \text{ Hz}$; $V_{meter} = 20 \text{ V}$
- $f = 1 \text{ kHz}$; $V_{meter} = 20 \text{ V}$
- $f = 10 \text{ kHz}$; $V_{meter} = 20.01 \text{ V}$
- $f = 100 \text{ kHz}$; $V_{meter} = 21.43 \text{ V}$
- $f = 1 \text{ MHz}$; $V_{meter} = 3.526 \text{ V}$

Follow-up question: explain why we see a "peak" at 100 kHz. How can the meter possibly see a voltage *greater* than the source voltage (20 V) at this frequency?

Answer 22

With no compensating capacitor:

- $f = 10 \text{ Hz}$; $V_{instrument} = 1.00 \text{ V}$
- $f = 1 \text{ kHz}$; $V_{instrument} = 0.701 \text{ V}$
- $f = 10 \text{ kHz}$; $V_{instrument} = 97.8 \text{ mV}$
- $f = 100 \text{ kHz}$; $V_{instrument} = 9.82 \text{ mV}$
- $f = 1 \text{ MHz}$; $V_{instrument} = 0.982 \text{ mV}$

With the 20 pF compensating capacitor in place:

- $f = 10 \text{ Hz}$; $V_{instrument} = 1.00 \text{ V}$
- $f = 1 \text{ kHz}$; $V_{instrument} = 1.00 \text{ V}$
- $f = 10 \text{ kHz}$; $V_{instrument} = 1.00 \text{ V}$
- $f = 100 \text{ kHz}$; $V_{instrument} = 1.00 \text{ V}$
- $f = 1 \text{ MHz}$; $V_{instrument} = 1.00 \text{ V}$

Hint: without the compensating capacitor, the circuit is a resistive voltage divider with a capacitive load. With the compensating capacitor, the circuit is a parallel set of equivalent voltage dividers, effectively eliminating the loading effect.

Follow-up question: as you can see, the presence of a compensation capacitor is not an option for a high-frequency, 10:1 oscilloscope probe. What safety hazard(s) might arise if a probe's compensation capacitor failed in such a way that the probe behaved as if the capacitor were not there at all?

Answer 23

For a bridge circuit to be "balanced" means that there is zero voltage between the two opposite corners of the circuit (where the battery does *not* connect). Achieving a condition of "balance" in a bridge circuit requires that the resistance ratios of the four "arms" of the circuit be in proportion:

$$\frac{R_1}{R_3} = \frac{R_2}{R_4}$$

Follow-up question: the bridge-balance equation shown above may also be written in a slightly different form:

$$\frac{R_1}{R_2} = \frac{R_3}{R_4}$$

Show algebraically how the first equation may be manipulated to take the form of the second equation, thus demonstrating these two equations' equivalence.

Answer 24

Even though impedance magnitudes may be balanced, the phase angles cannot.

Follow-up question: explain why it would *not* work to use an oscilloscope as the "detector" in this bridge circuit:

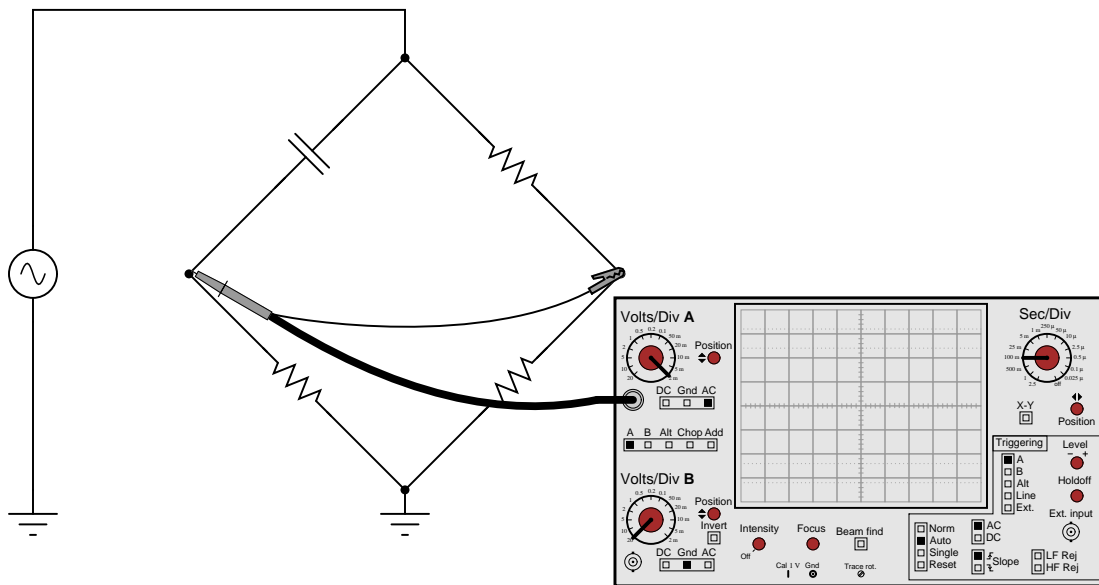

Hint: beware of *ground connections!*

Challenge question: explain how you *could* use this same oscilloscope as the detector in this bridge circuit without changing the ground location at the lower terminal of the AC source.

Answer 25

$$\mathbf{Z} = 1.975 \text{ k}\Omega \angle 90^\circ \text{ (polar form)}$$

$$\mathbf{Z} = 0 + j1.975 \text{ k}\Omega \text{ (rectangular form)}$$

Follow-up question: what type and size of component will provide this exact amount of impedance at 400 Hz?

Answer 26

$$\mathbf{Z} = 337.6 \text{ }\Omega \angle -90^\circ \text{ (polar form)}$$

$$\mathbf{Z} = 0 - j337.6 \text{ }\Omega \text{ (rectangular form)}$$

The simplest "null detector" for this type of AC bridge would be a sensitive pair of audio headphones, as 600 Hz is well within the audio range, and would be heard as a tone in the headphones.

Follow-up question: what type and size of component will provide this exact amount of impedance at 600 Hz?

Answer 27

Switch left: $\Theta = -45^\circ$ (V_{out} lagging behind the source voltage)

Switch right: $\Theta = +45^\circ$ (V_{out} leading ahead of the source voltage)

Follow-up question: identify the effects of various component failures in this circuit.

Answer 28

- The potentiometer wiper is fully left: $\Theta = -45^\circ$
- The potentiometer wiper is fully right: $\Theta = 45^\circ$
- The potentiometer wiper is perfectly centered: $\Theta = 0^\circ$

Follow-up question: this circuit works best with the excitation frequency is such that $X_C = R$. Write a formula that solves for the necessary frequency (f) to achieve this condition given a certain value of R .

Answer 29

With such a "shorted" failure on R_1 , there will be full source voltage at the output with the potentiometer wiper at the full-left position (no attenuation, no phase shift). The output voltage at the full-right wiper position will be mostly unaffected.

Follow-up question: identify another possible component failure that would exhibit the same symptoms.

Answer 30

An open failure of the fixed resistor in the upper-left arm of the bridge could cause this to happen:

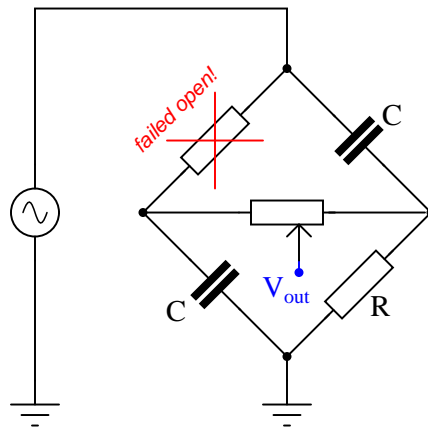

Follow-up question: identify another possible component failure that would exhibit the same symptoms.

Answer 31

In either case, the resonant frequency of the bar would *decrease*.

Answer 32

Capacitors store energy in potential form, while inductors store energy in kinetic form.

Answer 33

No resonant circuit is completely free of dissipative elements, whether resistive or radiative, and so some energy is lost each cycle.

Answer 34

The resonant frequency of this tank circuit may be increased by substituting a smaller-value capacitor in for the capacitor value it presently has.

Note: this is not the only way to increase this circuit's resonant frequency!

Answer 35

Large buildings have (very low) resonant frequencies, that may be matched by the motion of the ground in an earthquake, so that even a relatively small earthquake can cause major damage to the building.

Challenge question: after researching the behavior of mechanical resonant systems when driven by external oscillations of the same frequency, determine what the effects might be of external oscillations on an *electrical* resonant system.

Answer 36

$45 \Omega \angle 90^\circ$

Now, of course, you are wondering: "how can two series-connected components have a total impedance that is *less* than either of their individual impedances?" Don't series impedances add to equal the total impedance, just like series resistances? Be prepared to explain what is happening in this circuit, during discussion time with your classmates.

Answer 37

Circuit current = 10.88 mA RMS. As the frequency is gradually increased, the circuit current increases as well.

Follow-up question: what do you suppose might happen to the circuit current if the frequency is increased to the point that the reactances of the inductor and capacitor completely cancel each other? What safety concerns might arise from this possibility?

Answer 38

$f_{resonant} = 101.17 \text{ Hz}$. At this frequency, $Z_{series} = 0 \Omega$.

Answer 39

In a series LC circuit near resonance, Z_{total} is nearly zero, I_{total} is large, and both E_L and E_C are large as well.

Follow-up question: suppose the capacitor were to fail shorted. Identify how this failure would alter the circuit's current and voltage drops.

Answer 40

In a parallel LC circuit near resonance, Z_{total} is nearly infinite, I_{total} is small, and both I_L and I_C are large as well.

Follow-up question: suppose the inductor were to fail open. Identify how this failure would alter the circuit's current and voltage drops.

Answer 41

A series LC circuit will appear *inductive* when the source frequency exceeds the resonant frequency. A parallel LC circuit will appear *capacitive* in the same condition.

Answer 42

Capacitance exists any time there are two conductors separated by an insulating medium. Inductance exists any time a magnetic field is permitted to exist around a current-carrying conductor. Look for each of these conditions within the respective structures of inductors and capacitors to determine where the parasitic effects originate.

Answer 43

Parasitic reactance means that any single component is theoretically capable of resonance, all on its own!

Follow-up question: at what frequency would you expect a component to self-resonate? Would this be a very low frequency, a very high frequency, or a frequency within the circuit's normal operating range? Explain your answer.

Answer 44

Like many realistic problems, there is more than one possible solution. One way to approach this problem is to think of an analogous situation, and how the same type of problem was solved by someone else in that context. For example, how do automotive engineers solve the problem of mechanical resonance destabilizing a vehicle after it runs over a bump in the road? What did they invent to dampen the natural "bouncing" of the vehicle's suspension system, without defeating the purpose of the suspension system altogether? And how might you apply this principle to an electric circuit?

Follow-up question: besides shortening the life of the switch, what other undesirable effects can switch "arcing" have? Can you think of any scenarios where an arcing switch could pose a safety hazard?

Answer 45

Crystals are mechanical resonators made of a piezoelectric material (usually quartz).

Answer 46

Frequency	V_L	V_C	I_{total}
50 Hz	0.121 V	0.371 V	1.16 mA
60 Hz	0.221 V	0.471 V	1.77 mA
70 Hz	0.440 V	0.690 V	3.03 mA
80 Hz	1.24 V	1.49 V	7.48 mA
90 Hz	4.25 V	4.03 V	22.8 mA
100 Hz	1.07 V	0.821 V	5.16 mA

$$f_r = 87.6 \text{ Hz}$$

Answer 47

The "tank circuit" filters out all the unwanted radio frequencies, so that the listener hears only one radio station broadcast at a time.

Follow-up question: how might a variable capacitor be constructed, to suit the needs of a circuit such as this? Note that the capacitance range for a tuning capacitor such as this is typically in the pico-Farad range.

Answer 48

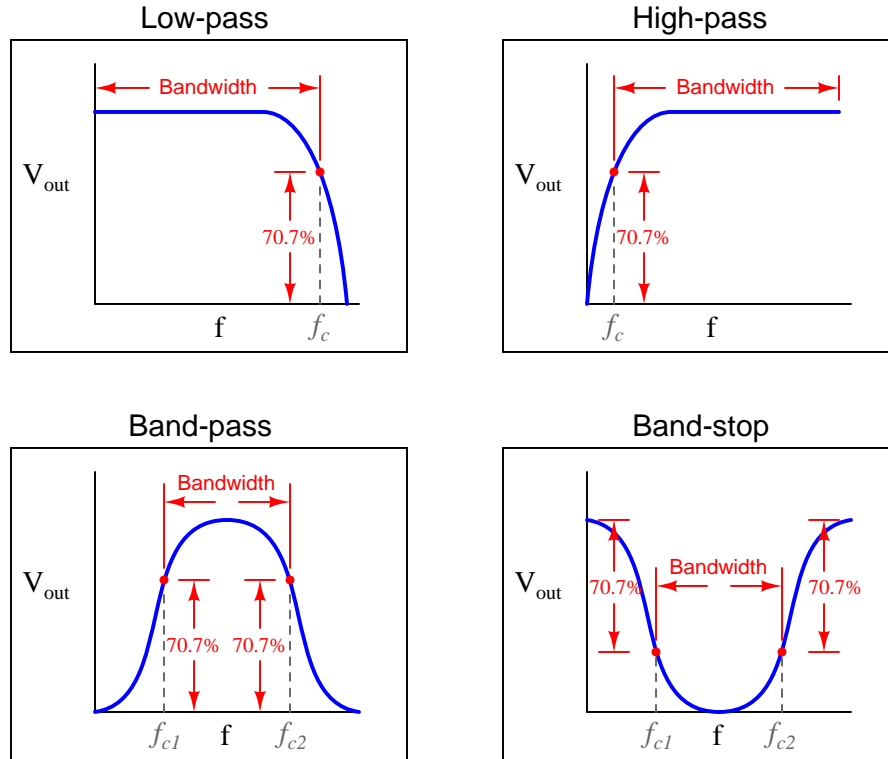

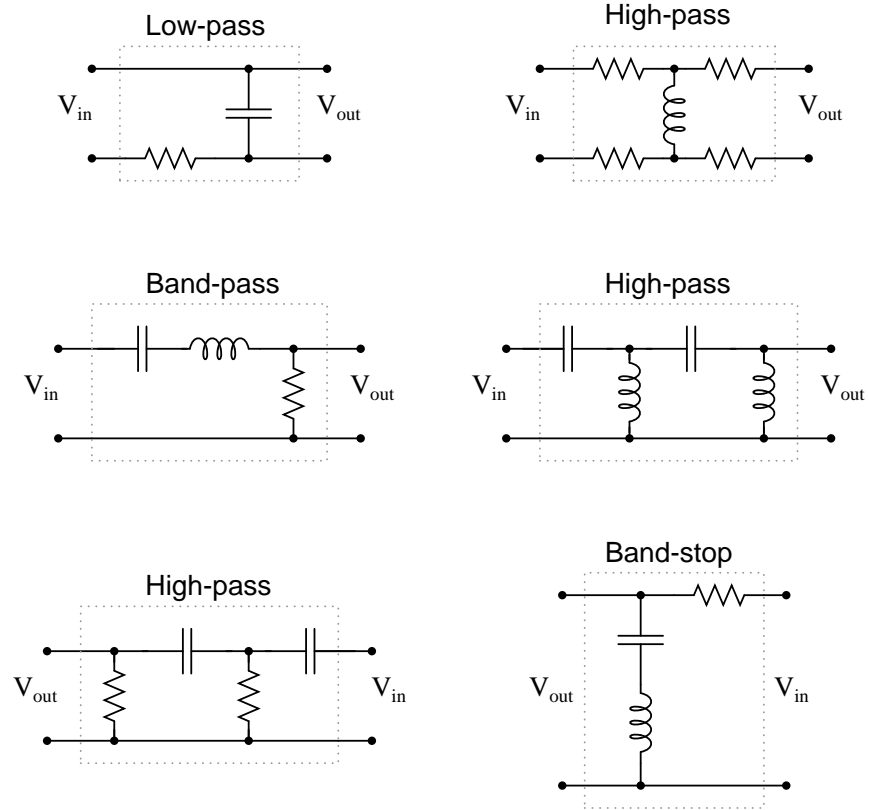

Follow-up question: in each of the circuits shown, identify at least one *single* component failure that has the ability to prevent any signal voltage from reaching the output terminals.

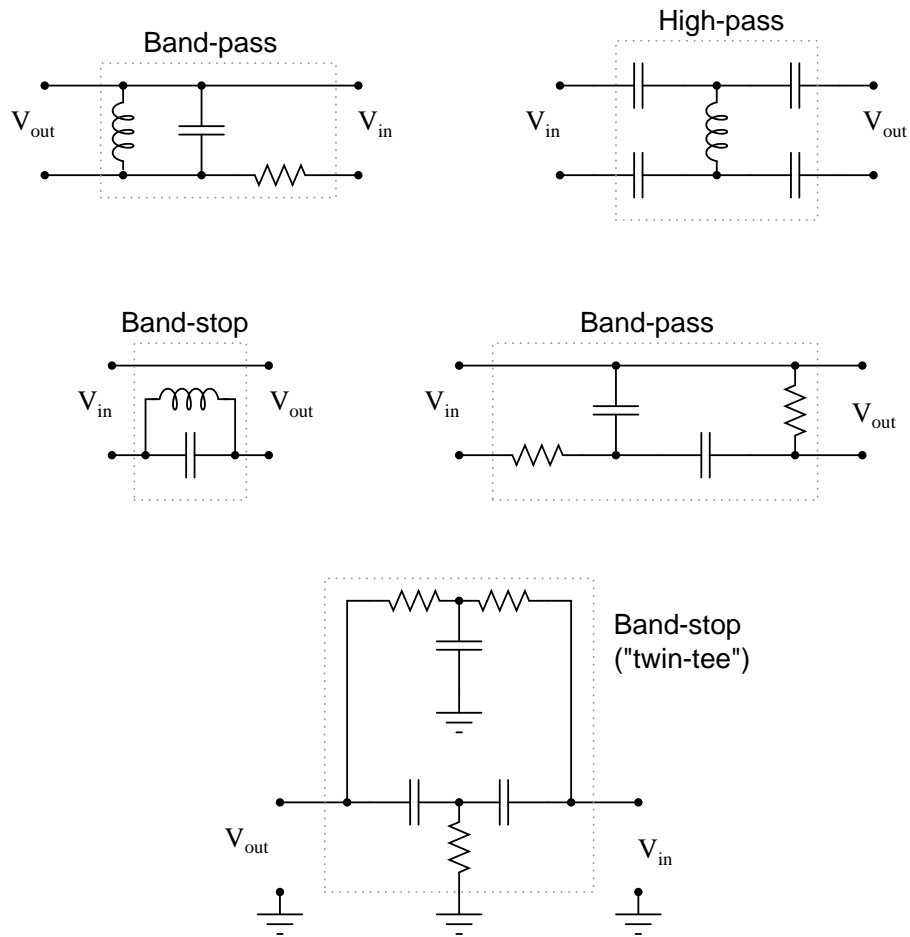

Unlike low-pass and high-pass filters, band-pass and band-stop filter circuits have *two* cutoff frequencies (f_{c1} and f_{c2})!

$$Q_{series} = \frac{E_C}{E_{source}} = \frac{E_L}{E_{source}}$$

$$Q_{parallel} = \frac{I_C}{I_{source}} = \frac{I_L}{I_{source}}$$

Follow-up question: what unique safety hazards may high-Q resonant circuits pose?

$$Q = \frac{1}{R} \sqrt{\frac{L}{C}}$$

Answer 54

$$f_r = 6.79 \text{ kHz}$$

$$\text{Bandwidth} = 289.4 \text{ Hz}$$

$$f_1 = 6.64 \text{ kHz}$$

$$f_2 = 6.93 \text{ kHz}$$

Follow-up question: how would a decrease in the Q ("quality factor") of the circuit affect the bandwidth, or would it at all?

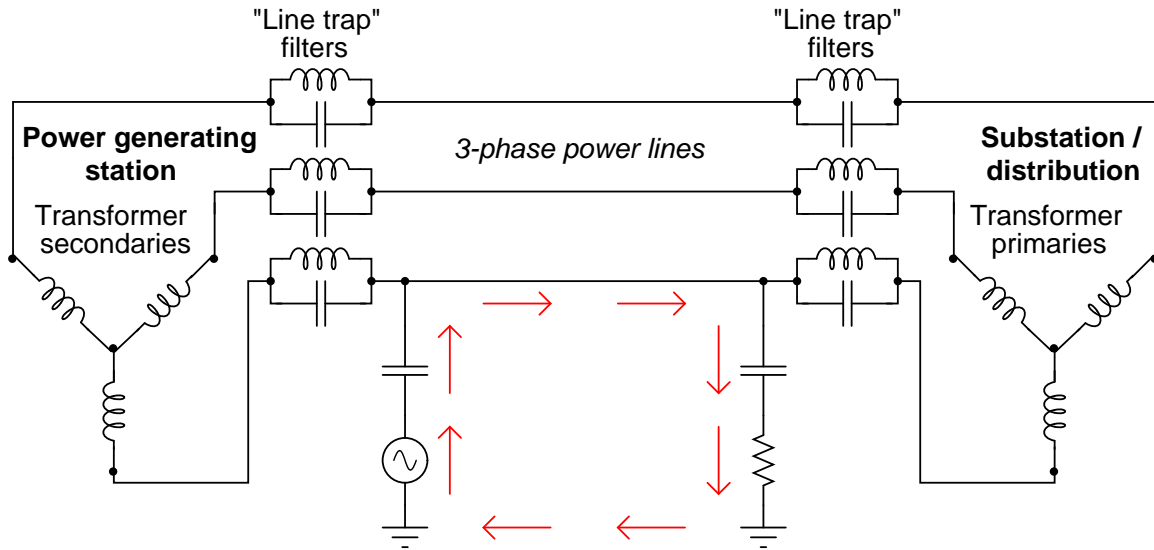

Follow-up question #1: trace the path of line-frequency (50 Hz or 60 Hz) load current in this system, identifying which component of the line trap filters (L or C) is more important to the passage of power to the load. Remember that the line trap filters are tuned to resonate at the frequency of the communication signal (50-150 kHz is typical).

Follow-up question #2: coupling capacitor units used in power line carrier systems are special-purpose, high-voltage devices. One of the features of a standard coupling capacitor unit is a *spark gap* intended to "clamp" overvoltages arising from lightning strikes and other transient events on the power line:

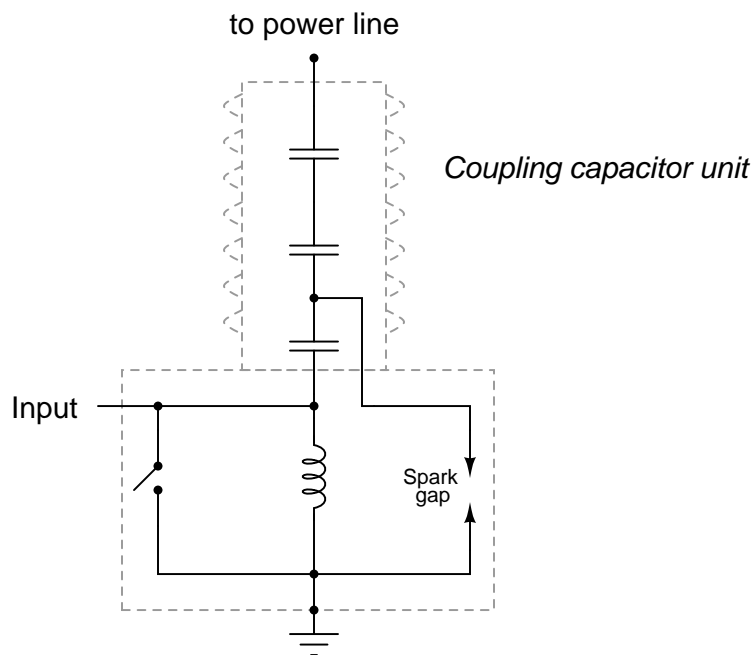

Explain how such a spark gap is supposed to work, and why it functions as an over-voltage protection device.

Answer 56

The introduction of the line-tuning units increases the efficiency of signal coupling by exploiting the principle of *resonance* between series-connected capacitors and inductors.

Challenge question: there are many applications in electronics where we couple high-frequency AC signals by means of capacitors alone. If capacitive reactance is any concern, we just use capacitors of large enough value that the reactance is minimal. Why would this not be a practical option in a power-line carrier system such as this? Why could we not (or why *would* we not) just choose coupling capacitors with very high capacitances, instead of adding extra components to the system?

Answer 57

The steeper plot corresponds to the circuit with the greatest Q .

Follow-up question: assuming both the inductance and the capacitance values are the same in these two resonant circuits, explain which circuit has the greatest resistance (R_1 or R_2).

Challenge question: what does the word "normalized" mean with respect to the vertical axis scale of the Bode plot?

Answer 58

Hint: the greater the value of Q , the less bandwidth a resonant circuit will have.

Answer 59

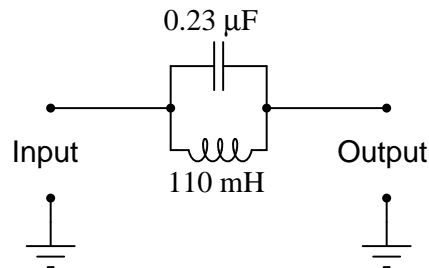

The bandwidth of this 1 kHz notch filter is approximately 29 Hz.

Follow-up question: suppose you looked around but could not find a capacitor with a value of 0.23 μF . What could you do to obtain this exact capacitance value? Be as specific and as practical as you can in your answer!

Answer 60

The steeper plot corresponds to the circuit with the greatest $\frac{L}{C}$ ratio.

Follow-up question: what kind of instrument(s) would you use to plot the response of a real resonant circuit in a lab environment? Would an oscilloscope be helpful with this task? Why or why not?

Answer 61

Use circuit simulation software to verify your predicted and measured parameter values.

Answer 62

Use circuit simulation software to verify your predicted and measured parameter values.

Answer 63

Use circuit simulation software to verify your predicted and measured parameter values.

Answer 64

Use circuit simulation software to verify your predicted and measured parameter values.

Answer 65

I do not provide a grading rubric here, but elsewhere.

Answer 66

Be sure to document all steps taken and conclusions made in your troubleshooting!

Answer 67

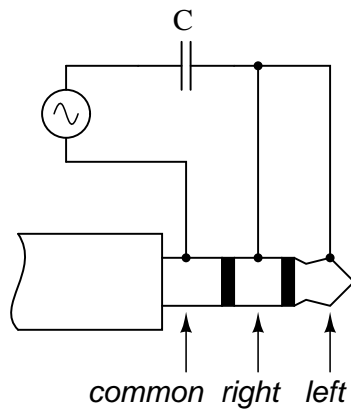

Answer 68

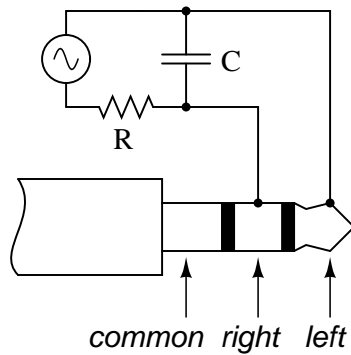

Answer 69

Addition and subtraction:

$$(5 + j6) + (2 - j1) = \\ \mathbf{7 + j5}$$

$$(10 - j8) + (4 - j3) = \\ \mathbf{14 - j11}$$

$$(-3 + j0) + (9 - j12) = \\ \mathbf{6 - j12}$$

$$(3 + j5) - (0 - j9) = \\ \mathbf{3 + j14}$$

$$(25 - j84) - (4 - j3) = \\ \mathbf{21 - j81}$$

$$(-1500 + j40) + (299 - j128) = \\ \mathbf{-1201 - j88}$$

$$(25\angle 15^\circ) + (10\angle 74^\circ) = \\ \mathbf{31.35\angle 30.87^\circ}$$

$$(1000\angle 43^\circ) + (1200\angle -20^\circ) = \\ \mathbf{1878.7\angle 8.311^\circ}$$

$$(522\angle 71^\circ) - (85\angle 30^\circ) = \\ \mathbf{461.23\angle 77.94^\circ}$$

Multiplication and division:

$$(25\angle 15^\circ) \times (12\angle 10^\circ) = \\ \mathbf{300\angle 25^\circ}$$

$$(1\angle 25^\circ) \times (500\angle -30^\circ) = \\ \mathbf{500\angle -5^\circ}$$

$$(522\angle 71^\circ) \times (33\angle 9^\circ) = \\ \mathbf{17226\angle 80^\circ}$$

$$\frac{10\angle -80^\circ}{1\angle 0^\circ} = \\ \mathbf{10\angle -80^\circ}$$

$$\frac{25\angle 120^\circ}{3.5\angle -55^\circ} = \\ \mathbf{7.142\angle 175^\circ}$$

$$\frac{-66\angle 67^\circ}{8\angle -42^\circ} = \\ \mathbf{8.25\angle -71^\circ}$$

$$(3 + j5) \times (2 - j1) = \\ \mathbf{11 + j7}$$

$$(10 - j8) \times (4 - j3) = \\ \mathbf{16 - j62}$$

$$\frac{(3+j4)}{(12-j2)} = \\ \mathbf{0.1892 + j0.3649}$$

Reciprocation:

$$\frac{1}{(15\angle 60^\circ)} = \\ \mathbf{0.667\angle -60^\circ}$$

$$\frac{1}{(750\angle -38^\circ)} = \\ \mathbf{0.00133\angle 38^\circ}$$

$$\frac{1}{(10+j3)} = \\ \mathbf{0.0917 - j0.0275}$$

$$\frac{1}{\frac{1}{15\angle 45^\circ} + \frac{1}{92\angle -25^\circ}} = \\ \mathbf{14.06\angle 36.74^\circ}$$

$$\frac{1}{\frac{1}{1200\angle 73^\circ} + \frac{1}{574\angle 21^\circ}} = \\ \mathbf{425.7\angle 37.23^\circ}$$

$$\frac{1}{\frac{1}{23k\angle -67^\circ} + \frac{1}{10k\angle -81^\circ}} = \\ \mathbf{7.013k\angle -76.77^\circ}$$

$$\frac{1}{\frac{1}{110\angle -34^\circ} + \frac{1}{80\angle 19^\circ} + \frac{1}{70\angle 10^\circ}} = \\ \mathbf{29.89\angle 2.513^\circ}$$

$$\frac{1}{\frac{1}{89k\angle -5^\circ} + \frac{1}{15k\angle 33^\circ} + \frac{1}{9.35k\angle 45^\circ}} = \\ \mathbf{5.531k\angle 37.86^\circ}$$

$$\frac{1}{\frac{1}{512\angle 34^\circ} + \frac{1}{1k\angle -25^\circ} + \frac{1}{942\angle -20^\circ} + \frac{1}{2.2k\angle 44^\circ}} = \\ \mathbf{256.4\angle 9.181^\circ}$$

Answer 70

- Impedance of a single capacitor (C) = $-j\frac{1}{\omega C}$
- Impedance of a series resistor-capacitor (R, C) network = $R - j\frac{1}{\omega C}$
- Admittance of a parallel inductor-resistor (L, R) network = $\frac{1}{R} - j\frac{1}{\omega L}$
- Admittance of a parallel resistor-capacitor (R, C) network = $\frac{1}{R} + j\omega C$

Answer 71

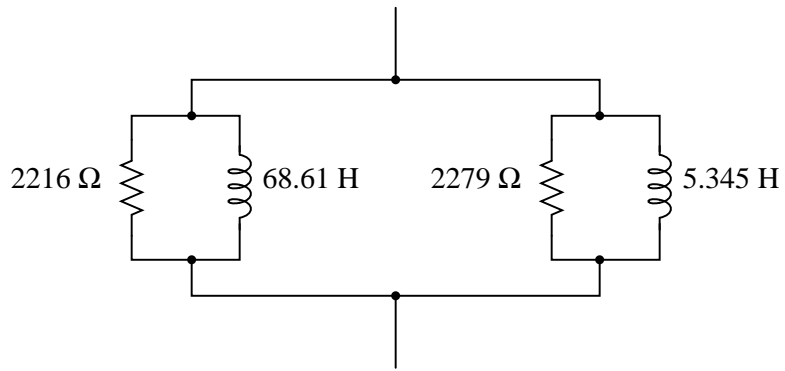

$$Z_{total} = 963.0 \Omega$$

Challenge question: from the simple-parallel equivalent circuit shown here, can you generate an equivalent circuit that is simple-series? In other words, can you calculate the proper values of R and L , that when connected in series, will have the same total impedance as this circuit?

Answer 72

$$\mathbf{V}_{out} = 2.228 \text{ V} \angle -26.973^\circ$$

Answer 73

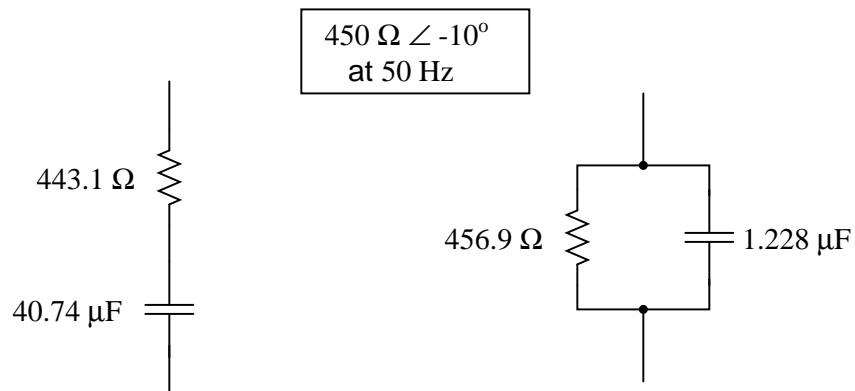

Answer 74

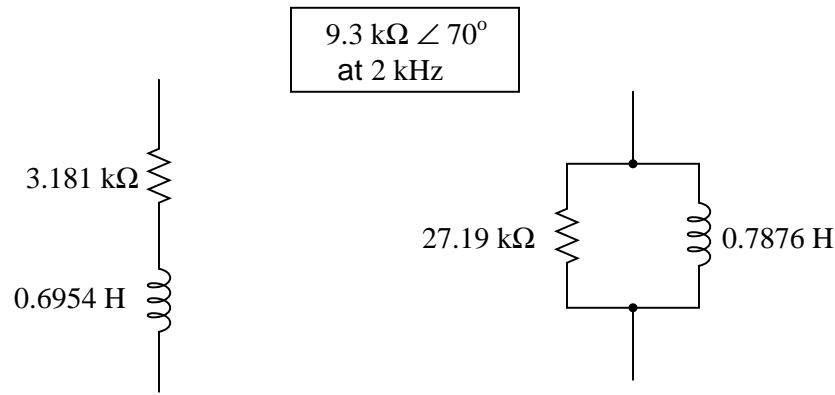

Answer 75

$$\mathbf{Z}_{\text{total}} = 1.526 \text{ k}\Omega \angle 9.336^\circ$$

Follow-up question: overall, does this network behave more like a capacitor, an inductor, or a resistor? Explain your answer.

Answer 76

$$\mathbf{Z}_{\text{total}} = 283.3 \text{ }\Omega \angle 9.899^\circ$$

Follow-up question: overall, does this network behave more like a capacitor, an inductor, or a resistor? Explain your answer.

Answer 77

$$\mathbf{Z}_{\text{total}} = 715.1 \text{ }\Omega \angle 35.8^\circ$$

Follow-up question: overall, does this network behave more like a capacitor, an inductor, or a resistor? Explain your answer.

Answer 78

	R_1	L_1	C_1	Total
V	8.92 V ∠ 145°	8.92 V ∠ 145°	24.8 V ∠ -11.9°	17 V ∠ 0°
I	40.6 mA ∠ 145°	94.7 mA ∠ 54.9°	103 mA ∠ 78.1°	103 mA ∠ 78.1°
Z	220 Ω ∠ 0°	94.2 Ω ∠ 90°	241 Ω ∠ -90°	165 Ω ∠ -78.1°

Answer 79

	R_1	L_1	C_1	C_2	Total
V	$2.51 \text{ V} \angle 4.68^\circ$	$2.95 \text{ V} \angle -175^\circ$	$5.45 \text{ V} \angle 4.68^\circ$	$2.51 \text{ V} \angle -4.67^\circ$	$5 \text{ V} \angle 0^\circ$
I	$2.09 \text{ mA} \angle 4.68^\circ$	$12.7 \text{ mA} \angle 94.7^\circ$	$12.7 \text{ mA} \angle 94.7^\circ$	$12.8 \text{ mA} \angle 85.3^\circ$	$12.8 \text{ mA} \angle 85.3^\circ$
Z	$1.2 \text{ k}\Omega \angle 0^\circ$	$232 \Omega \angle 90^\circ$	$430 \Omega \angle -90^\circ$	$196 \Omega \angle -90^\circ$	$389 \Omega \angle -85.3^\circ$

Answer 80

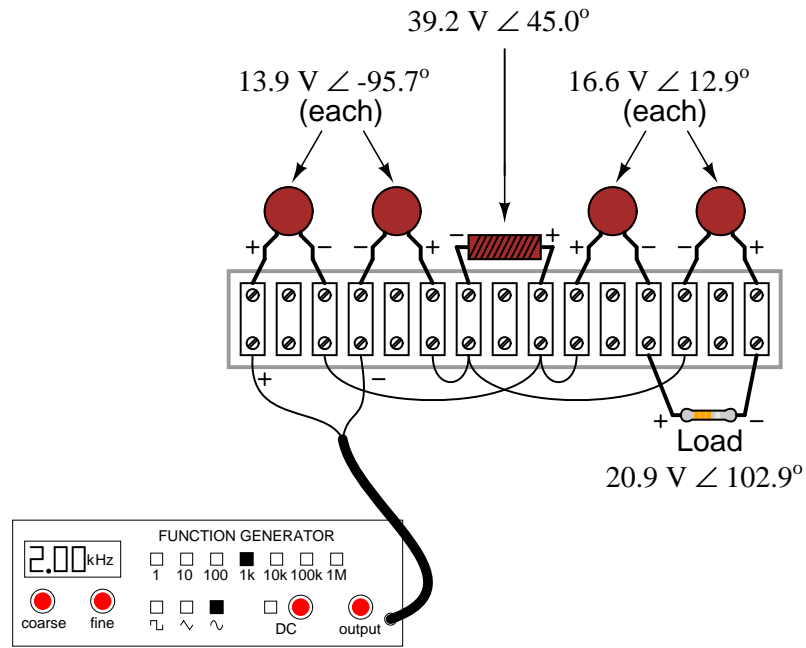

This circuit is a high-pass filter.

Due to the complexity of the algebra, I will show the complete solution here:

$$R_s + jX_s = \frac{1}{\frac{1}{R_p} - j\frac{1}{X_p}}$$

$$(R_s + jX_s) \left(\frac{1}{R_p} - j\frac{1}{X_p} \right) = 1$$

$$\frac{R_s}{R_p} - j\frac{R_s}{X_p} + j\frac{X_s}{R_p} - j^2\frac{X_s}{X_p} = 1$$

$$\frac{R_s}{R_p} - j\frac{R_s}{X_p} + j\frac{X_s}{R_p} + \frac{X_s}{X_p} = 1$$

$$\frac{R_s}{R_p} + \frac{X_s}{X_p} + j \left(\frac{X_s}{R_p} - \frac{R_s}{X_p} \right) = 1$$

Separating real and imaginary terms . . .

$$\frac{R_s}{R_p} + \frac{X_s}{X_p} = 1 \quad (\text{Real})$$

$$j \left(\frac{X_s}{R_p} - \frac{R_s}{X_p} \right) = j0 \quad (\text{Imaginary})$$

Just working with the imaginary equation now . . .

$$j \left(\frac{X_s}{R_p} - \frac{R_s}{X_p} \right) = j0$$

$$\frac{X_s}{R_p} - \frac{R_s}{X_p} = 0$$

$$\frac{X_s}{R_p} = \frac{R_s}{X_p}$$

$$X_p X_s = R_p R_s \quad (\text{Solution})$$

In answer to the challenge question, where we now introduce scalar relationships for series and parallel networks:

$$Z_s^2 = R_s^2 + X_s^2 \quad \text{Series impedance}$$

$$Z_p^2 = \frac{1}{\frac{1}{R_p^2} + \frac{1}{X_p^2}} \quad \text{Parallel impedance}$$

Solving each scalar impedance equation for reactance X. . .

$$X_s^2 = Z_s^2 - R_s^2 \quad X_p^2 = \frac{1}{\frac{1}{Z_p^2} - \frac{1}{R_p^2}}$$

Preparing the original solution for substitution . . .

$$X_p X_s = R_p R_s$$

$$(X_p X_s)^2 = (R_p R_s)^2$$

$$X_p^2 X_s^2 = R_p^2 R_s^2$$

Substituting these definitions for reactance into this prepared equation . . .

$$\left(\frac{1}{\frac{1}{Z_p^2} - \frac{1}{R_p^2}} \right) (Z_s^2 - R_s^2) = R_p^2 R_s^2$$

$$Z_s^2 - R_s^2 = (R_p^2 R_s^2) \left(\frac{1}{Z_p^2} - \frac{1}{R_p^2} \right)$$

$$Z_s^2 - R_s^2 = \frac{R_p^2 R_s^2}{Z_p^2} - \frac{R_p^2 R_s^2}{R_p^2}$$

$$Z_s^2 - R_s^2 = \frac{R_p^2 R_s^2}{Z_p^2} - R_s^2$$

$$Z_s^2 = \frac{R_p^2 R_s^2}{Z_p^2}$$

$$Z_p^2 Z_s^2 = R_p^2 R_s^2$$

$$(Z_p Z_s)^2 = (R_p R_s)^2$$

$$\sqrt{(Z_p Z_s)^2} = \sqrt{(R_p R_s)^2}$$

$$Z_p Z_s = R_p R_s$$

Since the two networks are known to be equivalent, $Z_p = Z_s$, which I will now simply label as Z . . .

$$ZZ = R_p R_s$$

$$Z^2 = R_p R_s \quad \text{(Solution)}$$

And since we know that $R_p R_s = X_p X_s$ as well . . .

$$Z^2 = X_p X_s \quad \text{(Solution)}$$

Follow-up question: the original equivalent networks were comprised of a resistor (R) and an inductor (L). Show that these solutions ($Z^2 = R_p R_s$ and $Z^2 = X_p X_s$) hold true for resistor-*capacitor* series and parallel equivalent networks as well.

Answer 82

$$L_x = 120 \text{ mH}$$
$$R_x = 70.175 \ \Omega$$

Answer 83

This means the source frequency is irrelevant to bridge balance.

Answer 84

$$Q = \frac{R_p}{X_p}$$

Follow-up question: what condition gives the greatest value for Q , a low parallel resistance or a high parallel resistance? Contrast this against the effects of low versus high resistance in a series LR circuit, and explain both scenarios.

Answer 85

The polarity markings provide a frame of reference for the phase angles of the voltage drops.

Answer 86

This circuit is a *band-pass* filter.

Answer 87

This circuit is a *band-stop* filter.

Answer 88

The resonant frequency of the circuit would *increase*.

Challenge question: what would happen to the Q of this filter circuit as a result of the fault within the inductor?

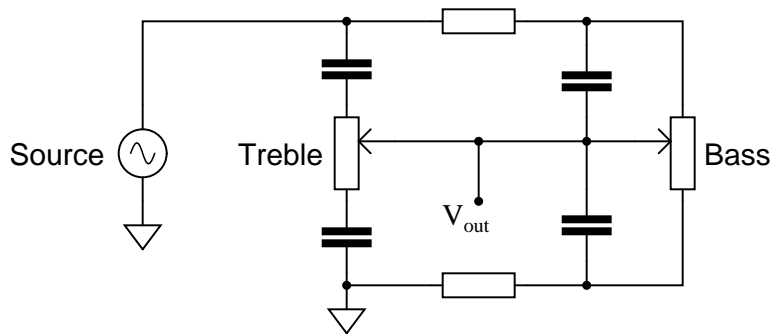
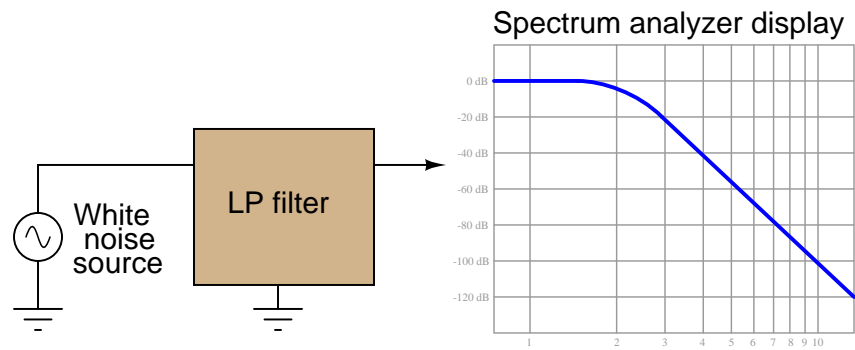
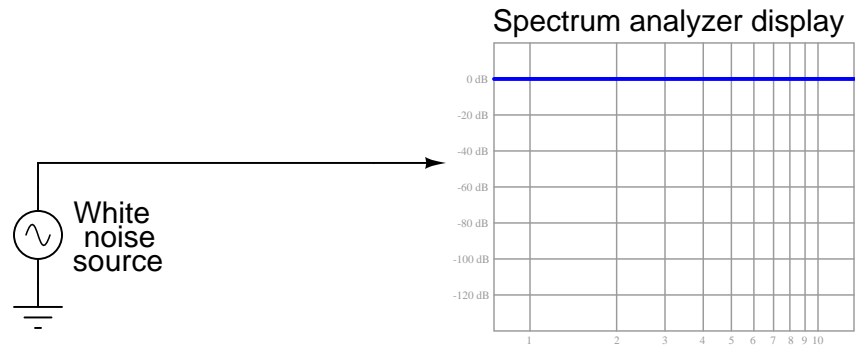

Here are some possibilities:

- R_1 failed open
- R_{pot1} failed open
- L_1 failed open
- Open wire connections between any of the above listed components

Answer 92

Most likely capacitor C_1 has failed shorted.

Answer 93

Most likely inductor L_1 has failed shorted.

Answer 94

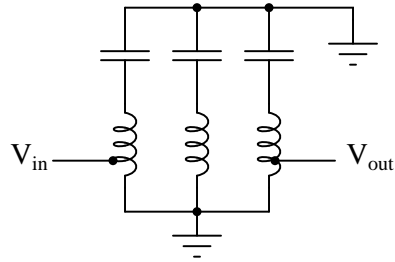

Follow-up question: why do you suppose multiple stages of tuned ("tank") circuits would be necessary in a high-quality tuner circuit? Why not just use a single tank circuit as a filter? Would that not be simpler and less expensive?

Notes 1

Here, the complementary nature of inductive and capacitive reactances is plain to see: they subtract in series. Challenge your students by asking them what the total impedance of this circuit would be if the two reactances were equal.

Notes 2

Ask your students why one of the reactance terms under the radicand is positive and the other is negative. The way this equation is written, does it matter which term is negative? Ask your students if we would obtain the same answer if it were written as $Z_{total} = \sqrt{R^2 + (X_C - X_L)^2}$ instead. Challenge them to answer this question without using a calculator!

Notes 3

Ask your students why one of the reactance terms under the radicand is positive and the other is negative. The way this equation is written, does it matter which term is negative? Ask your students if we would obtain the same answer if the equation were written as $Y_{total} = \sqrt{G^2 + (B_C - B_L)^2}$ instead. Challenge them to answer this question without using a calculator!

Notes 4

Ask your students how they obtained the phase angle for this circuit. There is more than one way to calculate this!

Students often have difficulty formulating a method of solution: determining what steps to take to get from the given conditions to a final answer. While it is helpful at first for you (the instructor) to show them, it is bad for you to show them too often, lest they stop thinking for themselves and merely follow your lead. A teaching technique I have found very helpful is to have students come up to the board (alone or in teams) in front of class to write their problem-solving strategies for all the others to see. They don't have to actually do the math, but rather outline the steps they would take, in the order they would take them. The following is a sample of a written problem-solving strategy for analyzing a series resistive-reactive AC circuit:

- Step 1:** Calculate all reactances (X).
- Step 2:** Draw an impedance triangle ($Z ; R ; X$), solving for Z
- Step 3:** Calculate circuit current using Ohm's Law: $I = \frac{V}{Z}$
- Step 4:** Calculate series voltage drops using Ohm's Law: $V = IZ$
- Step 5:** Check work by drawing a voltage triangle ($V_{total} ; V_1 ; V_2$), solving for V_{total}

By having students outline their problem-solving strategies, everyone gets an opportunity to see multiple methods of solution, and you (the instructor) get to see how (and if!) your students are thinking. An especially good point to emphasize in these "open thinking" activities is how to check your work to see if any mistakes were made.

Notes 5

As usual, the real point of this question is to get students to think about the analytical procedure(s) they use, and to engage their minds in problem-solving behavior. Ask them *why* they think the circuits behave inductively or capacitively.

Students often have difficulty formulating a method of solution: determining what steps to take to get from the given conditions to a final answer. While it is helpful at first for you (the instructor) to show them, it is bad for you to show them too often, lest they stop thinking for themselves and merely follow your lead. A teaching technique I have found very helpful is to have students come up to the board (alone or in teams) in front of class to write their problem-solving strategies for all the others to see. They don't have to actually do the math, but rather outline the steps they would take, in the order they would take them. The following is a sample of a written problem-solving strategy for analyzing a series resistive-reactive AC circuit:

Step 1: Calculate all reactances (X).

Step 2: Draw an impedance triangle ($Z ; R ; X$), solving for Z

Step 3: Calculate circuit current using Ohm's Law: $I = \frac{V}{Z}$

Step 4: Calculate series voltage drops using Ohm's Law: $V = IZ$

Step 5: Check work by drawing a voltage triangle ($V_{total} ; V_1 ; V_2$), solving for V_{total}

By having students outline their problem-solving strategies, everyone gets an opportunity to see multiple methods of solution, and you (the instructor) get to see how (and if!) your students are thinking. An especially good point to emphasize in these "open thinking" activities is how to check your work to see if any mistakes were made.

Notes 6

If students get stuck on the challenge question, remind them that an electric motor does mechanical *work*, which requires energy.

Notes 7

As usual, the most important part of your students' answers is not the figures themselves, but rather their methods of solution. Students should be very familiar with how to calculate the impedance of a series-connected group of components, but calculating component values from an impedance figure may be a challenge to some.

Notes 8

Being able to convert between series and parallel AC networks is a valuable skill for analyzing complex series-parallel combination circuits, because it means any series-parallel combination circuit may then be converted into an equivalent simple-series or simple-parallel, which is much easier to analyze.

Some students might ask why the conductance/susceptance triangle is "upside-down" compared to the resistance/reactance triangle. The reason has to do with the sign reversal of imaginary quantities when inverted: $\frac{1}{j} = -j$. The phase angle of a pure inductance's impedance is +90 degrees, while the phase angle of the same (pure) inductance's admittance is -90 degrees, due to reciprocation. Thus, while the X leg of the resistance/reactance triangle points up, the B leg of the conductance/susceptance triangle must point down.

Notes 9

This problem just happens to work out with whole numbers. Believe it or not, I chose these numbers entirely by accident one day, when setting up an example problem to show a student how to convert between series and parallel equivalent networks!

Notes 10

There are different methods of solving this problem. Use the discussion time to let students expound on how they approached the problem, pooling together their ideas. Their creativity may surprise you!

Notes 11

There are different methods of solving this problem. Use the discussion time to let students expound on how they approached the problem, pooling together their ideas. Their creativity may surprise you!

Notes 12

This is an interesting question, requiring the student to think creatively about how to convert one configuration of circuit into another, while maintaining the same total effect. As usual, the real purpose of a question like this is to develop problem-solving strategies, rather than to simply obtain an answer.

Notes 13

Once students learn to convert between complex impedances, equivalent series R-X circuits, and equivalent parallel R-X circuits, it becomes possible for them to analyze the most complex series-parallel impedance combinations imaginable *without* having to do arithmetic with complex numbers (magnitudes and angles at every step). It does, however, require that students have a good working knowledge of resistance, conductance, reactance, susceptance, impedance, and admittance, and how these quantities relate mathematically to one another in scalar form.

Notes 14

Once students learn to convert between complex impedances, equivalent series R-X circuits, and equivalent parallel R-X circuits, it becomes possible for them to analyze the most complex series-parallel impedance combinations imaginable *without* having to do arithmetic with complex numbers (magnitudes and angles at every step). It does, however, require that students have a good working knowledge of resistance, conductance, reactance, susceptance, impedance, and admittance, and how these quantities relate mathematically to one another in scalar form.

Notes 15

While rectangular notation is mathematically useful, it does not apply directly to measurements taken with real instruments. Some students might suggest that the 3.000 volt reading and the 4.000 volt reading on the other two voltmeters represent the rectangular components (real and imaginary, respectively) of voltage, but this is a special case. In cases where resistance and reactance are mixed (e.g. a practical inductor with winding resistance), the voltage magnitude will be neither the real nor the imaginary component, but rather the polar magnitude.

Notes 16

It is important for your students to realize that the two forms given in the answer are really the same quantity, just expressed differently. If it helps, draw a phasor diagram showing how they are equivalent.

This is really nothing more than an exercise in complex number arithmetic. Have your students present their solution methods on the board for all to see, and discuss how Ohm's Law and complex number formats (rectangular versus polar) relate to one another in this question.

Notes 17

Although there are other methods of solving for total impedance in a circuit such as this, I want students to become comfortable with series/parallel equivalents as an analysis tool.

Notes 18

Although there are other methods of solving for total impedance in a circuit such as this, I want students to become comfortable with series/parallel equivalents as an analysis tool.

Notes 19

Although there are other ways to calculate this voltage drop, it is good for students to learn the method of series-parallel subcircuit equivalents. If for no other reason, this method has the benefit of requiring less tricky math (no complex numbers needed!).

Have your students explain the procedures they used to find the answer, so that all may benefit from seeing multiple methods of solution and multiple ways of explaining it.

Notes 20

Yes, that is an AC current source shown in the schematic! In circuit analysis, it is quite common to have AC current sources representing idealized portions of an actual component. For instance *current transformers* (CT's) act very close to ideal AC current sources. Transistors in amplifier circuits also act as AC current sources, and are often represented as such for the sake of analyzing amplifier circuits.

Although there are other ways to calculate this voltage drop, it is good for students to learn the method of series-parallel subcircuit equivalents. If for no other reason, this method has the benefit of requiring less tricky math (no complex numbers needed!).

Have your students explain the procedures they used to find the answer, so that all may benefit from seeing multiple methods of solution and multiple ways of explaining it.

Notes 21

As your students what this indicates about the use of coaxial test cable for AC voltmeters. Does it mean that coaxial test cable is unusable for any measurement application, or may we use it with little or no concern in some applications? If so, which applications are these?

Notes 22

Explain to your students that " $\times 10$ " oscilloscope probes are made like this, and that the "compensation" capacitor in these probes is usually made adjustable to create a precise 9:1 match with the combined parasitic capacitance of the cable and oscilloscope.

Ask your students what the usable "bandwidth" of a home-made $\times 10$ oscilloscope probe would be if it had no compensating capacitor in it.

Notes 23

Challenge your students to write a "balance equation" describing how the ratios must relate to each other in order to achieve balance.

Notes 24

Explain to your students that AC bridges, while fundamentally the same as DC bridges, do have their differences. Their knowledge of AC circuit calculations (with complex numbers) should be enough for them to see why this is so.

Notes 25

So long as complex quantities are used, AC bridge circuits "balance" just the same way that DC bridge circuits balance. Consequently, this is really nothing new for your students if they've already studied DC Wheatstone bridge circuits.

Notes 26

So long as complex quantities are used, AC bridge circuits "balance" just the same way that DC bridge circuits balance. Consequently, this is really nothing new for your students if they've already studied DC Wheatstone bridge circuits.

Notes 27

This is a very interesting circuit to built and test. You may build one using 1 μF capacitors and 2.7 k Ω resistors that will successfully operate on 60 Hz power-line excitation.

Notes 28

This is a very interesting circuit to built and test. You may build one using 1 μF capacitors, 2.7 k Ω resistors, and a 100 k Ω potentiometer that will successfully operate on 60 Hz power-line excitation.

An interesting thing to note about using line power is that any distortions in the excitation sine-wave will become obvious when the potentiometer wiper is turned toward the differentiating position (where Θ is positive). If listened to with an audio detector, you may even hear the change in timbre while moving the wiper from one extreme to the other. If excited by a "clean" sine-wave, however, no change in timbre should be heard because there are no harmonics present.

Notes 29

It is essential, of course, that students understand the operational principle of this circuit before they may speculate at the effects of various component faults. You may find it necessary to discuss this circuit in detail with your students before they are ready to troubleshoot it.

In case anyone asks, the symbolism $R_{pot} \gg R$ means "potentiometer resistance is *much* greater than the fixed resistance value."

Notes 30

It is essential, of course, that students understand the operational principle of this circuit before they may even attempt to diagnose possible faults. You may find it necessary to discuss this circuit in detail with your students before they are ready to troubleshoot it.

In case anyone asks, the symbolism $R_{pot} \gg R$ means "potentiometer resistance is *much* greater than the fixed resistance value."

Notes 31

Electrical resonance is so closely related to physical resonance, that I believe questions like this help students grasp the concept better. Everyone knows what resonance is in the context of a vibrating object (tuning fork, bell, wind chime, guitar string, cymbal head), even if they have never heard of the term "resonance" before. Getting them to understand that mechanical resonance depends on the complementary qualities of mass and elasticity primes their minds for understanding that electrical resonance depends on the complementary qualities of inductance and capacitance.

Notes 32

Ask your students to define "potential" and "kinetic" energy. These terms, of course, are central to the question, and I have not bothered to define them. This omission is purposeful, and it is the students' responsibility to research the definitions of these words in the process of answering the question. If a substantial number of your students stopped trying to answer the question when they encountered new words (instead of taking initiative to find out what the words mean), then it indicates a need to focus on independent learning skills (and attitudes!).

Discuss a typical "cycle" of energy exchange between kinetic and potential forms in a vibrating object, and then relate this exchange process to the oscillations of a tank circuit (capacitor and inductor).

Notes 33

A circuit such as this is easy to build and demonstrate, but you will need a digital storage oscilloscope to successfully capture the damped oscillations. Also, the results may be tainted by switch "bounce," so be prepared to address that concept if you plan to demonstrate this to a live audience.

You might want to ask your students how they would suggest building a "tank circuit" that is as free from energy losses as possible. If a perfect tank circuit could be built, how would it act if momentarily energized by a DC source such as in this setup?

Notes 34

Challenge your students to explain another method for increasing the resonant frequency of this tank circuit, besides decreasing the value of the capacitor. Discuss how any of these alterations to the circuit affect the typical energy "cycle" between kinetic and potential forms, and *why* they lead to an increased frequency.

Notes 35

Many, many examples of mechanical resonance exist, some of which are quite dramatic. A famous example of destructive mechanical resonance (of a well-known bridge in Washington state) has been immortalized in video form, and is easily available on the internet. If possible, provide the means within your classroom to display a video clip on computer, for any of the students who happen to find this video file and bring it to discussion.

Notes 36

This question is an exercise in complex number arithmetic, and it is quite counter-intuitive at first. Discuss this problem in depth with your students, so that they are sure to comprehend the phenomenon of series-canceling impedances.

Notes 37

In order for your students to arrive at the answer of circuit current increasing with frequency, they must perform a few calculations at different frequencies. Do this together, as a group, and note how the circuit's impedance changes with frequency.

Notes 38

The answer gives away the meaning of this question: the determination of an LC circuit's *resonant* frequency. Students may be surprised at the total impedance figure of 0Ω , but this is really nothing more than an extension of the "impedance cancellation" concept they've seen before in other series LC circuit questions. In this case, the cancellation concept has merely been taken to the ultimate level of *total* cancellation between the two impedances.

Notes 39

This question is given without a specified source frequency for a very important reason: to encourage students to "experiment" with numbers and explore concepts on their own. Sure, I could have given a power supply frequency as well, but I chose not to because I wanted students to set up part of the problem themselves.

In my experience teaching, students will often choose to remain passive with regard to a concept they do not understand, rather than aggressively pursue an understanding of it. They would rather wait and see if the instructor happens to cover that concept during class time than take initiative to explore it on their own. Passivity is a recipe for failure in life, and this includes intellectual endeavors as much as anything else. The fundamental trait of autonomous learning is the habit of pursuing the answer to a question, without being led to do so. Questions like this, which purposefully omit information, and thus force the student to think creatively and independently, teach them to develop this trait.

Notes 40

This question is given without a specified source frequency for a very important reason: to encourage students to "experiment" with numbers and explore concepts on their own. Sure, I could have given a power supply frequency as well, but I chose not to because I wanted students to set up part of the problem themselves.

In my experience teaching, students will often choose to remain passive with regard to a concept they do not understand, rather than aggressively pursue an understanding of it. They would rather wait and see if the instructor happens to cover that concept during class time than take initiative to explore it on their own. Passivity is a recipe for failure in life, and this includes intellectual endeavors as much as anything else. The fundamental trait of autonomous learning is the habit of pursuing the answer to a question, without being led to do so. Questions like this, which purposefully omit information, and thus force the student to think creatively and independently, teach them to develop this trait.

Notes 41

Ask your students to explain their answers mathematically.

Notes 42

Once students have identified the *mechanisms* of parasitic reactances, challenge them with inventing means of minimizing these effects. This is an especially practical exercise for understanding parasitic inductance in capacitors, which is very undesirable in decoupling capacitors used to stabilize power supply voltages near integrated circuit "chips" on printed circuit boards. Fortunately, most of the stray inductance in a decoupling capacitor is due to how it's mounted to the board, rather than anything within the structure of the capacitor itself.

Notes 43

This question grew out of several years' worth of observations, where students would discover self-resonant effects in large (> 1 Henry) inductors at modest frequencies. Being a recurring theme, I thought it prudent to include this question within my basic electronics curriculum.

One component that tends to be more immune to self-resonance than others is the lowly resistor, especially resistors of large value. Ask your students why they think this might be. A mechanical analogy to self-resonance is the natural frequency of vibration for an object, given the unavoidable presence of both elasticity and mass in any object. The mechanical systems most immune to vibratory resonance, though, are those with a high degree of intrinsic *friction*.

Notes 44

Besides posing a practical problem-solving scenario to students, this question is a good lead-in to the topic of *antiresonance*. Be sure to allow plenty of class discussion time for this question, as many topics are likely to be covered as students discuss alternative problem-solving strategies.

Notes 45

My answer here is purposefully vague, to inspire students to research on their own.

Notes 46

This is nothing more than number-crunching, though some students may have found novel ways to speed up their calculations or verify their work.

Notes 47

Challenge your students to describe how to change stations on this radio receiver. For example, if we are listening to a station broadcasting at 1000 kHz and we want to change to a station broadcasting at 1150 kHz, what do we have to do to the circuit?

Be sure to discuss with them the construction of an adjustable capacitor (air dielectric).

Notes 48

Although "bandwidth" is usually applied first to band-pass and band-stop filters, students need to realize that it applies to the other filter types as well. This question, in addition to reviewing the definition of bandwidth, also reviews the definition of cutoff frequency. Ask your students to explain where the 70.7% figure comes from. Hint: *half-power* point!

Notes 49

Some of these filter designs are resonant in nature, while others are not. Resonant circuits, especially when made with high-Q components, approach ideal band-pass (or -block) characteristics. Discuss with your students the different design strategies between resonant and non-resonant band filters.

The high-pass filter containing both inductors and capacitors may at first appear to be some form of resonant (i.e. band-pass or band-stop) filter. It actually *will* resonate at some frequency(ies), but its overall behavior is still high-pass. If students ask about this, you may best answer their queries by using computer simulation software to plot the behavior of a similar circuit (or by suggesting they do the simulation themselves).

Regarding the follow-up question, it would be a good exercise to discuss which suggested component failures are more likely than others, given the relatively likelihood for capacitors to fail shorted and inductors and resistors to fail open.

Notes 50

Some of these filter designs are resonant in nature, while others are not. Resonant circuits, especially when made with high-Q components, approach ideal band-pass (or -block) characteristics. Discuss with your students the different design strategies between resonant and non-resonant band filters.

Although resonant band filter designs have nearly ideal (theoretical) characteristics, band filters built with capacitors and resistors only are also popular. Ask your students why this might be. Is there any reason inductors might purposefully be avoided when designing filter circuits?

Notes 51

This question presents a good opportunity to ask students to draw the Bode plot of a typical band-pass or band-stop filter on the board in front of the class to illustrate the concept. Don't be afraid to let students up to the front of the classroom to present their findings. It's a great way to build confidence in them and also to help suppress the illusion that you (the teacher) are the Supreme Authority of the classroom!

Notes 52

Ask your students to determine which type of danger(s) are posed by high-Q series and parallel resonant circuits, respectively. The answer to this question may seem paradoxical at first: that series resonant circuits whose overall impedance is nearly zero can manifest large voltage drops, while parallel resonant circuits whose overall impedance is nearly infinite can manifest large currents.

Notes 53

This is merely an exercise in algebra. However, knowing how these three component values affects the Q factor of a resonant circuit is a valuable and practical insight!

Notes 54

The formulae required to calculate these parameters are easily obtained from any basic electronics text. No student should have trouble finding this information.

Notes 55

Although power line carrier technology is not used as much for communication in high-voltage distribution systems as it used to be – now that microwave, fiber optic, and satellite communications technology has superseded this older technique – it is still used in lower voltage power systems including residential (home) wiring. Ask your students if they have heard of any consumer technology capable of broadcasting any kind of data or information along receptacle wiring. "X10" is a mature technology for doing this, and at this time (2004) there are devices available on the market allowing one to plug telephones into power receptacles to link phones in different rooms together without having to add special telephone cabling.

Even if your students have not yet learned about three-phase power systems or transformers, they should still be able to discern the circuit path of the communications signal, based on what they know of capacitors and inductors, and how they respond to signals of arbitrarily high frequency.

Information on the coupling capacitor units was obtained from page 452 of the *Industrial Electronics Reference Book*, published by John Wiley & Sons in 1948 (fourth printing, June 1953). Although power line carrier technology is not as widely used now as it was back then, I believe it holds great educational value to students just learning about filter circuits and the idea of mixing signals of differing frequency in the same circuit.

Notes 56

Although power line carrier technology is not used as much for communication in high-voltage distribution systems as it used to be – now that microwave, fiber optic, and satellite communications technology has come of age – it is still used in lower voltage power systems including residential (home) wiring. Ask your students if they have heard of any consumer technology capable of broadcasting any kind of data or information along receptacle wiring. "X10" is a mature technology for doing this, and at this time (2004) there are devices available on the market allowing one to plug telephones into power receptacles to link phones in different rooms together without having to add special telephone cabling.

I think this is a really neat application of resonance: the complementary nature of inductors to capacitors works to overcome the less-than-ideal coupling provided by capacitors alone. Discuss the challenge question with your students, asking them to consider some of the practical limitations of capacitors, and how an inductor/capacitor resonant pair solves the line-coupling problem better than an oversized capacitor.

Notes 57

When your students study resonant filter circuits, they will better understand the importance of Q . For now, though, it is enough that they comprehend the basic notion of how Q impacts the voltage dropped by any one component in a series resonant circuit across a range of frequencies.

Notes 58

The purpose of this question is not necessarily to get students to look this formula up in a book, but rather to develop their qualitative reasoning and critical thinking skills. Forgetting the exact form of an equation is not a rare event, and it pays to be able to select between different forms based on a conceptual understanding of what the formula is supposed to predict.

Note that the question asks students to identify the *wrong* formula, and not to tell which one is right. If all we have are these two formulae to choose from, and a memory too weak to confidently recall the correct form, the best that logic can do is eliminate the wrong formula. The formula making the most sense according to our qualitative analysis may or may not be *precisely* right, because we could very well be forgetting a multiplicative constant (such as 2π).

Notes 59

In my answer I used the series-resonant formula $f_r = \frac{1}{2\pi\sqrt{LC}}$, since the series formula gives good approximations for parallel resonant circuits with Q factors in excess of 10.

The follow-up question is very practical, since it is often common to need a component value that is non-standard. Lest any of your students suggest obtaining a *variable* capacitor for this task, remind them that variable capacitors are typically rated in the pico-Farad range, and would be much too small for this application.

Notes 60

Discuss with your students why the LC circuit with the greatest $\frac{L}{C}$ ratio has the steeper response, in terms of reactances of the respective components at the resonant frequency.

The purpose of this question is to get students to realize that not all resonant circuits with identical resonant frequencies are alike! Even with ideal components (no parasitic effects), the frequency response of a simple LC circuit varies with the particular choice of component values. This is not obvious from inspection of the resonant frequency formula:

$$f_r = \frac{1}{2\pi\sqrt{LC}}$$

Notes 61

Use a sine-wave function generator for the AC voltage source. Specify a cutoff frequency within the audio range.

I recommend setting the function generator output for 1 volt, to make it easier for students to measure the point of "cutoff". You may set it at some other value, though, if you so choose (or let students set the value themselves when they test the circuit!).

I also recommend having students use an oscilloscope to measure AC voltage in a circuit such as this, because some digital multimeters have difficulty accurately measuring AC voltage much beyond line frequency range. I find it particularly helpful to set the oscilloscope to the "X-Y" mode so that it draws a thin line on the screen rather than sweeps across the screen to show an actual waveform. This makes it easier to measure peak-to-peak voltage.

Notes 62

This is perhaps the most reliable means of measuring inductance without an impedance bridge or an LCR meter. You may wish to ask your students to explain *why* this method of measurement is so good (hint: they must explain why the inductor's intrinsic resistance has no effect on the measurement).

I prefer this particular circuit design for L measurement because series resistance does not skew the resonant point, and because the series capacitor prevents any possible DC current from "biasing" the inductor's core.

If your students own high-quality multimeters capable of measuring audio-frequency AC current and frequency, then the best way to do this is to replace the resistor R_1 with their ammeters. Otherwise, use an oscilloscope to measure (maximum) voltage dropped across R_1 .

In order to obtain good measurements using this technique, I recommend following these guidelines:

- Choose a value of R_1 low enough to give a sharp bandwidth, but not so low that the voltage signal dropped across it is "fuzzy" with noise and difficult to accurately discern the period of.
- Choose a value for C_1 as low as possible to give sharp bandwidth (thereby maximizing the $\frac{L}{C}$ ratio), without pushing the circuit's resonant frequency too close to the inductor's self-resonant frequency.
- Avoid frequencies above the audio range, lest your students measure the inductor's self-resonant point!
- Use minimal output from the signal generator, to avoid voltage and current levels that will approach core saturation in the inductor.

I've had fair results using one of the windings of a small audio output transformer (center-tapped 1000 Ω primary winding, with 8 Ω secondary winding) as the inductor, connected in series with either a 0.1 μF or a 0.47 μF metal-film capacitor, all in series with a 100 ohm resistor. For best results, of course, pre-measure the value of the capacitor rather than go by its advertised value.

I have also used a 100 mH inductor (nominal), in series with a 0.033 μF capacitor and 100 Ω resistor, with good results.

Notes 63

Use a sine-wave function generator for the AC voltage source. Specify standard resistor, capacitor, and inductor values. I have used a small 100 mH inductor, a 0.033 μF capacitor, and 100 Ω resistor with good success. In any case I recommend keeping the resonant frequency within the mid-audio range (1 kHz to 10 kHz) to avoid problems with low inductor Q (frequency too low) and stray capacitance and inductance issues (frequency too high).

I also recommend having students use an oscilloscope to measure AC voltage in a circuit such as this, because some digital multimeters have difficulty accurately measuring AC voltage much beyond line frequency range. I find it particularly helpful to set the oscilloscope to the "X-Y" mode so that it draws a thin line on the screen rather than sweeps across the screen to show an actual waveform. This makes it easier to measure peak-to-peak voltage.

An extension of this exercise is to incorporate troubleshooting questions. Whether using this exercise as a performance assessment or simply as a concept-building lab, you might want to follow up your students' results by asking them to predict the consequences of certain circuit faults.

Notes 64

This is a very interesting circuit to built and test. You may build one using 1 μF capacitors, 2.7 k Ω resistors, and a 100 k Ω potentiometer that will successfully operate on 60 Hz power-line excitation. If you prefer to use audio frequency power, try 0.047 μF capacitors, 1 k Ω resistors, a 100 k Ω potentiometer, and 3.386 kHz for the source frequency.

An interesting thing to note about using line power is that any distortions in the excitation sine-wave will become obvious when the potentiometer wiper is turned toward the differentiating position (where Θ is positive). If listened to with an audio detector, you may even hear the change in timbre while moving the wiper from one extreme to the other. If excited by a "clean" sine-wave, however, no change in timbre should be heard because there are no harmonics present.

Notes 65

The idea of a troubleshooting log is three-fold. First, it gets students in the habit of documenting their troubleshooting procedure and thought process. This is a valuable habit to get into, as it translates to more efficient (and easier-followed) troubleshooting on the job. Second, it provides a way to document student steps for the assessment process, making your job as an instructor easier. Third, it reinforces the notion that each and every measurement or action should be followed by reflection (conclusion), making the troubleshooting process more efficient.

Notes 66

The purpose of this assessment rubric is to act as a sort of “contract” between you (the instructor) and your student. This way, the expectations are all clearly known in advance, which goes a long way toward disarming problems later when it is time to grade.

Notes 67

This question challenges students to determine what “common” means, in relation to the speaker connections. Also, it requires that they translate the nice, clean schematic diagram into a real-world illustration, which is a difficult task for some (but well worth the time to practice!).

Notes 68

This question challenges students to determine what “common” means, in relation to the speaker connections. Also, it requires that they translate the nice, clean schematic diagram into a real-world illustration, which is a difficult task for some (but well worth the time to practice!).

Notes 69

I suggest you let your students discover how to use the complex number facilities of their scientific calculators on their own. My experience has been that students both young and old take to this challenge readily, because they realize learning how to use their calculators will save them a tremendous amount of hand calculations!

Notes 70

One possible point of confusion here is the sign of j after inversion. If it is not evident from the answers, $\frac{1}{j}$ is equal to $-j$, so that the impedance of an inductor ($j\omega L$) becomes $-j\frac{1}{\omega L}$ when converted into an admittance.

Notes 71

Fundamentally, this question asks students to generate an equivalent parallel R-X circuit from a given series R-X circuit. In this particular circuit, there are two series-connected R-X branches, resulting in an equivalent parallel circuit with four branches.

Calculating the circuit’s total impedance as a scalar figure involves simplifying the circuit once more into two components: a resistance and a reactance.

Notes 72

Discuss with your students what a good procedure might be for calculating the unknown values in this problem, and also how they might check their work.

Students often have difficulty formulating a method of solution: determining what steps to take to get from the given conditions to a final answer. While it is helpful at first for you (the instructor) to show them, it is bad for you to show them too often, lest they stop thinking for themselves and merely follow your lead. A teaching technique I have found very helpful is to have students come up to the board (alone or in teams) in front of class to write their problem-solving strategies for all the others to see. They don't have to actually do the math, but rather outline the steps they would take, in the order they would take them.

By having students outline their problem-solving strategies, everyone gets an opportunity to see multiple methods of solution, and you (the instructor) get to see how (and if!) your students are thinking. An especially good point to emphasize in these "open thinking" activities is how to check your work to see if any mistakes were made.

Notes 73

Once students learn to convert between complex impedances, equivalent series R-X circuits, and equivalent parallel R-X circuits, it becomes possible for them to analyze the most complex series-parallel impedance combinations imaginable *without* having to do arithmetic with complex numbers (magnitudes and angles at every step). It does, however, require that students have a good working knowledge of resistance, conductance, reactance, susceptance, impedance, and admittance, and how these quantities relate mathematically to one another in scalar form.

Notes 74

Once students learn to convert between complex impedances, equivalent series R-X circuits, and equivalent parallel R-X circuits, it becomes possible for them to analyze the most complex series-parallel impedance combinations imaginable *without* having to do arithmetic with complex numbers (magnitudes and angles at every step). It does, however, require that students have a good working knowledge of resistance, conductance, reactance, susceptance, impedance, and admittance, and how these quantities relate mathematically to one another in scalar form.

Notes 75

Students should find series impedance calculations very similar to series (DC) resistance calculations, the only significant difference being the use of complex instead of scalar numbers.

Notes 76

Students should find parallel impedance calculations very similar to parallel (DC) resistance calculations, the only significant difference being the use of complex instead of scalar numbers. This makes parallel impedance calculations difficult, no doubt about it. Attaining a solution for this problem will involve a lot of arithmetic, with lots of room for calculation error.

Notes 77

Students should find parallel impedance calculations very similar to parallel (DC) resistance calculations, the only significant difference being the use of complex instead of scalar numbers. This makes parallel impedance calculations difficult, no doubt about it. Attaining a solution for this problem will involve a lot of arithmetic, with lots of room for calculation error.

Notes 78

Students often have difficulty formulating a method of solution: determining what steps to take to get from the given conditions to a final answer. While it is helpful at first for you (the instructor) to show them, it is bad for you to show them too often, lest they stop thinking for themselves and merely follow your lead. A teaching technique I have found very helpful is to have students come up to the board (alone or in teams) in front of class to write their problem-solving strategies for all the others to see. They don't have to actually do the math, but rather outline the steps they would take, in the order they would take them. The following is a sample of a written problem-solving strategy for analyzing a series resistive-reactive AC circuit:

Step 1: Calculate all reactances (X).

Step 2: Draw an impedance triangle ($Z ; R ; X$), solving for Z

Step 3: Calculate circuit current using Ohm's Law: $I = \frac{V}{Z}$

Step 4: Calculate series voltage drops using Ohm's Law: $V = IZ$

Step 5: Check work by drawing a voltage triangle ($V_{total} ; V_1 ; V_2$), solving for V_{total}

By having students outline their problem-solving strategies, everyone gets an opportunity to see multiple methods of solution, and you (the instructor) get to see how (and if!) your students are thinking. An especially good point to emphasize in these "open thinking" activities is how to check your work to see if any mistakes were made.

Notes 79

Students often have difficulty formulating a method of solution: determining what steps to take to get from the given conditions to a final answer. While it is helpful at first for you (the instructor) to show them, it is bad for you to show them too often, lest they stop thinking for themselves and merely follow your lead. A teaching technique I have found very helpful is to have students come up to the board (alone or in teams) in front of class to write their problem-solving strategies for all the others to see. They don't have to actually do the math, but rather outline the steps they would take, in the order they would take them. The following is a sample of a written problem-solving strategy for analyzing a series resistive-reactive AC circuit:

Step 1: Calculate all reactances (X).

Step 2: Draw an impedance triangle ($Z ; R ; X$), solving for Z

Step 3: Calculate circuit current using Ohm's Law: $I = \frac{V}{Z}$

Step 4: Calculate series voltage drops using Ohm's Law: $V = IZ$

Step 5: Check work by drawing a voltage triangle ($V_{total} ; V_1 ; V_2$), solving for V_{total}

By having students outline their problem-solving strategies, everyone gets an opportunity to see multiple methods of solution, and you (the instructor) get to see how (and if!) your students are thinking. An especially good point to emphasize in these "open thinking" activities is how to check your work to see if any mistakes were made.

Notes 80

The real "answer" to this question is the circuit analysis technique employed. Ask your students, perhaps working teams, to explain how to arrive at the different voltage drop figures. Note any similarities in analysis technique to that of DC circuit analysis.

Notes 81

Yes, it is out of character for me to show two pages of solution in the "answer" section of one of my questions! I usually do not provide this much information in my answers. However, in this case I believe there is still much to be learned from examining a proof like this shown step-by-step.

You may wish to ask your students to explain the rationale behind each step, especially in the first part where we deal with real and imaginary terms. One point that may be especially confusing is where I separate the real and imaginary terms, setting the imaginary quantity equal to $j0$. Some students may not see where the $j0$ comes from, since the preceding (complex) expression was simply equal to 1. Remind them that "1" is a real quantity, possessing an (implied) imaginary component of 0, and that it could very well have been written as $1 + j0$.

Notes 82

There is actually a way to solve for the values of L_x and R_x in a Maxwell-Wien bridge circuit without using complex numbers at all. If one or more of your students find out how to do so through their research, don't consider it "cheating." Rather, applaud their research, because they found a quicker path to a solution.

This, of course, doesn't mean you don't ask them to work through the problem using complex numbers! The benefit of students researching other means of solution simply provides more alternative solution strategies to the same problem, which is a very good thing.

Notes 83

A rule that students will need to be aware of in order to follow all the algebra shown here is $\frac{1}{j} = -j$. A brief proof is given here:

$$j^2 = -1$$

$$\frac{1}{j^2} = \frac{1}{-1}$$

$$\frac{j}{j^2} = \frac{j}{-1}$$

$$\frac{j}{j^2} = -j$$

$$\frac{1}{j} = -j$$

Otherwise, the admittance equation ($\mathbf{Y}_s = \frac{1}{R_s} + j\omega C_s$) will not make sense.

One type of AC bridge is called a *noise bridge*, using a "noise" (broadly mixed frequencies) source as the excitation voltage. Discuss with your students how the Maxwell-Wien bridge would be a suitable topology for use with a noise source, whereas other bridge topologies might not.

Notes 84

This is primarily an exercise in algebraic substitution, but it also challenges students to think deeply about the nature of Q and what it means, especially in the follow-up question.

Notes 85

Ask your students why polarity markings need to be provided in DC electrical networks, as an essential part of the voltage figures. Why is an answer for a voltage drop incomplete if not accompanied by polarity markings in a DC circuit? Discuss this with your students, then ask them to extrapolate this principle to AC circuits. When we are accounting for the *phase shift* of a voltage drop in our answer, does the "polarity" of the voltage drop matter?

Notes 86

As usual, ask your students to explain *why* the answer is correct, not just repeat the answer that is given!

Notes 87

As usual, ask your students to explain *why* the answer is correct, not just repeat the answer that is given!

Notes 88

Determining the effect on resonant frequency is a simple matter of qualitative analysis with the resonant frequency formula. The effect on Q (challenge question) may be answered just as easily if the students know the formula relating bandwidth to L , C , and R .

Notes 89

The purpose of this question, besides providing a convenient way to characterize a filter circuit, is to introduce students to the concept of a *white noise source* and also to strengthen their understanding of a spectrum analyzer's function.

In case anyone happens to notice, be aware that the rolloff shown for this filter circuit is *very* steep! This sort of sharp response could never be realized with a simple one-resistor, one-capacitor ("first order") filter. It would have to be a multi-stage analog filter circuit or some sort of active filter circuit.

Notes 90

The most important answer to this question is *how* your students arrived at the correct potentiometer identifications. If none of your students were able to figure out how to identify the potentiometers, give them this tip: use the *superposition theorem* to analyze the response of this circuit to both low-frequency signals and high-frequency signals. Assume that for bass tones the capacitors are opaque ($Z = \infty$) and that for treble tones they are transparent ($Z = 0$). The answers should be clear if they follow this technique.

This general problem-solving technique – analyzing two or more "extreme" scenarios to compare the results – is an important one for your students to become familiar with. It is extremely helpful in the analysis of filter circuits!

Notes 91

The circuit shown in the question is not very practical for direct headphone use, unless low-value resistors are used. Otherwise, the losses are too great and maximum volume suffers. An improvement over the original circuit is one where a matching transformer is used to effectively increase the impedance of the headphones:

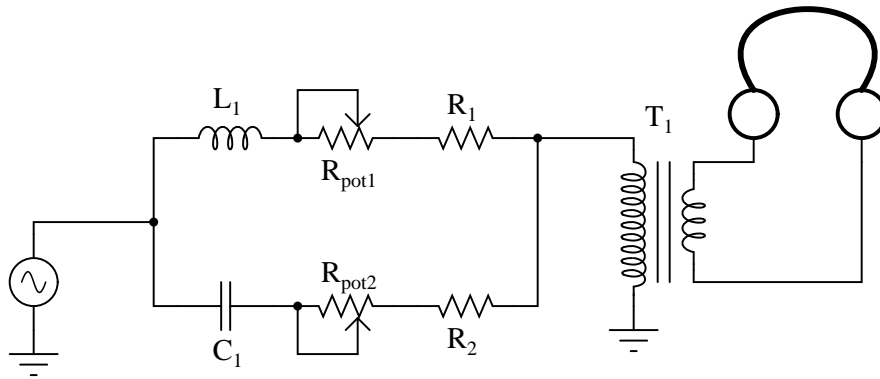

Notes 92

Discuss with your students how this circuit functions before they offer their ideas for faulted components or wires. One must understand the basic operating principle(s) of a circuit before one can troubleshoot it effectively!

Notes 93

Discuss with your students how this circuit functions before they offer their ideas for faulted components or wires. One must understand the basic operating principle(s) of a circuit before one can troubleshoot it effectively!

Notes 94

If students have a difficult time seeing where the capacitance comes from, remind them that we are dealing with *very* high frequencies here, and that air between metal parts is a sufficient dielectric to create the needed capacitance.

The coupling between coils may be a bit more difficult to grasp, especially if your students have not yet studied mutual inductance. Suffice it to say that energy is transferred between coils with little loss at high frequencies, permitting an RF signal to enter at one end of the resonator and exit out the other without any wires physically connecting the stages together.