

## Logarithms for analog circuits

This worksheet and all related files are licensed under the Creative Commons Attribution License, version 1.0. To view a copy of this license, visit <http://creativecommons.org/licenses/by/1.0/>, or send a letter to Creative Commons, 559 Nathan Abbott Way, Stanford, California 94305, USA. The terms and conditions of this license allow for free copying, distribution, and/or modification of all licensed works by the general public.

---

Resources and methods for learning about these subjects (list a few here, in preparation for your research):

## Questions

---

### Question 1

The concept of a mathematical *power* is familiar to most students of algebra. For instance, ten to the third power means this:

$$10^3 = 10 \times 10 \times 10 = 1000$$

. . . and eight to the seventh power means this:

$$8^7 = 8 \times 8 \times 8 \times 8 \times 8 \times 8 \times 8 = 2,097,152$$

Just as subtraction is the inverse function of addition, and division is the inverse function of multiplication (because with inverse functions, one "undoes" the other), there is also an inverse function for a power and we call it the *logarithm*.

Re-write the expression  $10^3 = 1000$  so that it uses the same quantities (10, 3, and 1000) in the context of a logarithm instead of a power, just as the subtraction is shown here to be the inverse of addition, and division is shown to be the inverse of multiplication in the following examples:

$$3 + 8 = 11 \quad (+ \text{ and } - \text{ are inverse functions}) \quad 11 - 3 = 8$$

$$2 \times 7 = 14 \quad (\times \text{ and } \div \text{ are inverse functions}) \quad 14 \div 2 = 7$$

$$10^3 = 1000 \quad (\text{powers and logs are inverse functions}) \quad \log_{10} ??? = ???$$

[file 02677](#)

---

### Question 2

Given the following mathematical expression, write another one defining a *logarithm* using the same variables:

$$\text{If: } x^y = z \quad \text{Then: } \log_z ? = ?$$

[file 02679](#)

---

### Question 3

Electronic calculators with logarithm capability have at least two different types of logarithms: *common* logarithm and *natural* logarithm, symbolized as "log" and "ln", respectively. Explain what the difference is between these two types of logarithms.

[file 02678](#)

---

---

Question 4

Note the following logarithmic identities, using the "common" (base 10) logarithm:

$$\log 10 = 1$$

$$\log 100 = 2$$

$$\log 1000 = 3$$

$$\log 10000 = 4$$

In the first equation, the numbers 10 and 1 were related together by the log function. In the second equation, the numbers 100 and 2 were related together by the same log function, and so on.

Rewrite the four equations together in such a way that the same numbers are related to each other, but without writing "log". In other words, represent the same mathematical relationships using some mathematical function other than the common logarithm function.

[file 02680](#)

---

Question 5

Note the following logarithmic identities, using the "common" (base 10) logarithm:

$$\log 0.1 = -1$$

$$\log 0.01 = -2$$

$$\log 0.001 = -3$$

$$\log 0.0001 = -4$$

In the first equation, the numbers 0.1 and 1 were related together by the log function. In the second equation, the numbers 0.01 and 2 were related together by the same log function, and so on.

Rewrite the four equations together in such a way that the same numbers are related to each other, but without writing "log". In other words, represent the same mathematical relationships using some mathematical function other than the common logarithm function.

[file 02681](#)

---

Question 6

Examine the following progression of mathematical statements:

$$(10^2)(10^3) = 100000$$

$$10^{2+3} = 100000$$

$$10^5 = 100000$$

What does this pattern indicate? What principle of algebra is illustrated by these three equations? Next, examine this progression of mathematical statements:

$$\log 10^5 = \log 100000 = 5$$

$$\log 10^{2+3} = \log 100000 = 5$$

$$\log 10^2 + \log 10^3 = \log 100000 = 5$$

What does this pattern indicate? What principle of algebra is illustrated by these three equations?  
[file 02682](#)

---

Question 7

Examine this progression of mathematical statements:

$$(100)(1000) = 100000$$

$$(100)(1000) = 10^5$$

$$\log[(100)(1000)] = \log 10^5$$

$$\log 100 + \log 1000 = \log 10^5$$

$$\log 10^2 + \log 10^3 = \log 10^5$$

$$2 + 3 = 5$$

What began as a multiplication problem ended up as an addition problem, through the application of logarithms. What does this tell you about the utility of logarithms as an arithmetic tool?  
[file 02683](#)

---

Question 8

Suppose you owned a scientific calculator with two broken buttons: the multiply ( $\times$ ) and divide ( $\div$ ). Demonstrate how you could solve this simple multiplication problem using only logarithms, addition, and antilogarithms (powers):

$$7 \times 5 = ???$$

The answer to this problem was easy enough for you to figure out without a calculator at all, so here are some more practice problems for you to try:

- $23 \times 35 =$
- $781 \times 92 =$
- $19.4 \times 60 =$
- $0.019 \times 2.6 =$

[file 02685](#)

---

#### Question 9

Examine this progression of mathematical statements:

$$\frac{1000}{100} = 10$$

$$\frac{1000}{100} = 10^1$$

$$\log\left(\frac{1000}{100}\right) = \log 10^1$$

$$\log 1000 - \log 100 = \log 10^1$$

$$\log 10^3 - \log 10^2 = \log 10^1$$

$$3 - 2 = 1$$

What began as a division problem ended up as a subtraction problem, through the application of logarithms. What does this tell you about the utility of logarithms as an arithmetic tool?

[file 02684](#)

---

#### Question 10

Suppose you owned a scientific calculator with two broken buttons: the multiply ( $\times$ ) and divide ( $\div$ ). Demonstrate how you could solve this simple multiplication problem using only logarithms, addition, and antilogarithms (powers):

$$12 \div 3 = ???$$

The answer to this problem was easy enough for you to figure out without a calculator at all, so here are some more practice problems for you to try:

- $122 \div 35 =$
- $781 \div 92 =$
- $19.4 \div 60 =$
- $3.5 \div 0.21 =$

[file 02686](#)

---

Question 11

Examine this progression of mathematical statements:

$$(1000)^2 = 1000000$$

$$(1000)^2 = 10^6$$

$$\log[(1000)^2] = \log 10^6$$

$$(2)(\log 1000) = \log 10^6$$

$$(2)(\log 10^3) = \log 10^6$$

$$(2)(3) = 6$$

What began as an exponential problem ended up as a multiplication problem, through the application of logarithms. What does this tell you about the utility of logarithms as an arithmetic tool?

[file 02687](#)

---

Question 12

Suppose you owned a scientific calculator with two broken buttons: the power ( $y^x$ ) and root ( $\sqrt[x]{y}$ ). Demonstrate how you could solve this simple power problem using only logarithms, multiplication, and antilogarithms (powers):

$$3^4 = ???$$

The answer to this problem was easy enough for you to figure out without a calculator at all, so here are some more practice problems for you to try:

- $25^6 =$
- $564^3 =$
- $0.224^2 =$
- $41^{0.3} =$

[file 02690](#)

---

Question 13

Examine this progression of mathematical statements:

$$\sqrt{1000} = 10^{1.5}$$

$$\log \sqrt{1000} = \log (10^{1.5})$$

$$\log \left(1000^{\frac{1}{2}}\right) = \log (10^{1.5})$$

$$\frac{1}{2}(\log 1000) = \log (10^{1.5})$$

$$\frac{1}{2}(\log 10^3) = \log (10^{1.5})$$

$$\frac{3}{2}(\log 10) = \log (10^{1.5})$$

$$\frac{3}{2}(1) = \log (10^{1.5})$$

$$\frac{3}{2} = \log (10^{1.5})$$

$$\frac{3}{2} = 1.5$$

What began as a fractional exponent problem ended up as a simple fraction, through the application of logarithms. What does this tell you about the utility of logarithms as an arithmetic tool?

[file 02688](#)

---

Question 14

Suppose you owned a scientific calculator with two broken buttons: the power ( $y^x$ ) and root ( $\sqrt[x]{y}$ ). Demonstrate how you could solve this simple root problem using only logarithms, division, and antilogarithms (powers):

$$\sqrt[3]{8} = ???$$

The answer to this problem was easy enough for you to figure out without a calculator at all, so here are some more practice problems for you to try:

- $\sqrt[4]{13} =$
- $\sqrt[5]{209} =$
- $2.5\sqrt[9935]{9935} =$
- ${}^{9.2}\sqrt{0.15} =$

[file 02689](#)

---

### Question 15

*Logarithms* have interesting properties, which we may exploit in electronic circuits to perform certain complex operations. In this question, I recommend you use a hand calculator to explore these properties.

Calculate the following:

- $10^{\log 3} =$
- $\log(10^8) =$
  
- $e^{\ln 3} =$
- $\ln(e^8) =$
  
- $10^{(\log 3 + \log 5)} =$
- $e^{(\ln 3 + \ln 5)} =$
  
- $10^{(\log 2.2 + \log 4)} =$
- $e^{(\ln 2.2 + \ln 4)} =$
  
- $10^{(\log 12 - \log 4)} =$
- $e^{(\ln 12 - \ln 4)} =$
  
- $10^{(2 \log 3)} =$
- $e^{(2 \ln 3)} =$
  
- $10^{(\frac{\log 25}{2})} =$
- $e^{(\frac{\ln 25}{2})} =$

file 01018



Question 16

You may be wondering why anyone would bother using logarithms to solve arithmetic problems for which we have perfectly good and effective digital electronic calculator functions at our disposal. For example, why would anyone do this:

$$10^{\log 7 + \log 5}$$

. . . when they could just do the following on the same calculator?

$$7 \times 5$$

The quick answer to this very good question is, "when it is more difficult to directly multiply two numbers." The trouble is, most people have a difficult time imagining when it would ever be easier to take two logarithms, add them together, and raise ten to that power than it would be to simply multiply the original two numbers together.

The answer to *that* mystery is found in operational amplifier circuitry. As it turns out, it is much easier to build single opamp circuits that add, subtract, exponentiate, or take logarithms than it is to build one that directly multiplies or divides two quantities (analog voltages) together.

We may think of these opamp functions as "blocks" which may be interconnected to perform composite arithmetic functions:

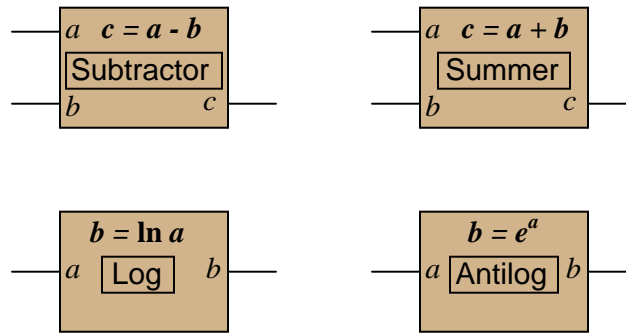

Using this model of specific math-function "blocks," show how the following set of analog math function blocks may be connected together to multiply two analog voltages together:

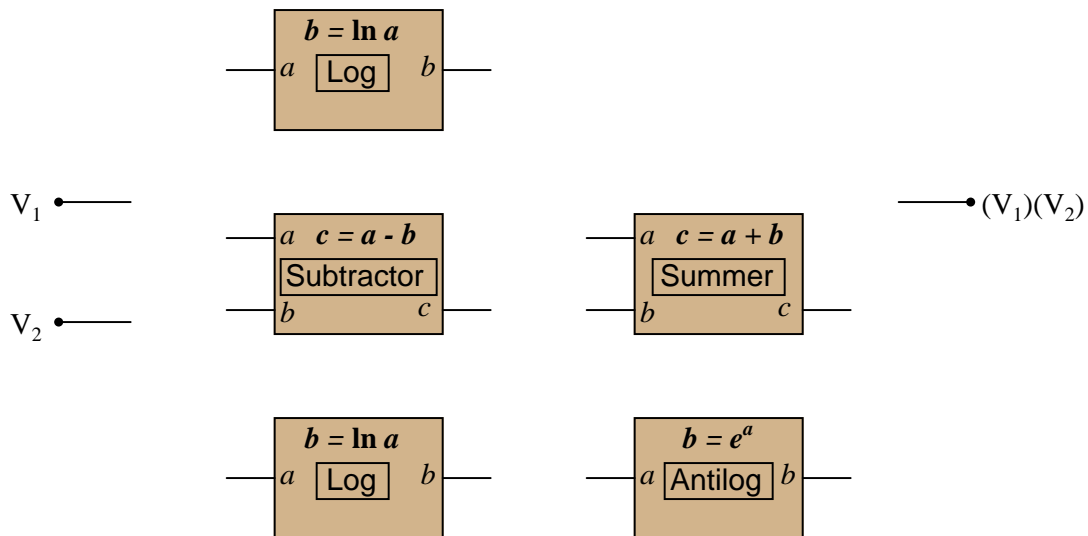



## Answers

---

Answer 1

$$10^3 = 1000 \quad (\text{powers and logs are inverse functions}) \quad \log_{10} 1000 = 3$$

---

Answer 2

$$\text{If: } x^y = z \quad \text{Then: } \log_x z = y$$

---

Answer 3

The common logarithm function assumes a "base" value of ten, whereas the natural logarithm assumes a base value of  $e$  (Euler's constant).

Follow-up question: what is the approximate value of  $e$ ? How can you get your calculator to give you the answer (rather than looking it up in a math book?)

---

Answer 4

$$10^1 = 10$$

$$10^2 = 100$$

$$10^3 = 1000$$

$$10^4 = 10000$$

---

Answer 5

$$10^{-1} = 0.1$$

$$10^{-2} = 0.01$$

$$10^{-3} = 0.001$$

$$10^{-4} = 0.0001$$

---

Answer 6

First pattern:

The product of two base numbers with different exponents is equal to that base number raised to the power of the exponents' sum.

Second pattern:

The sum of two logarithms is equal to the logarithm of those two numbers' product.

---

Answer 7

That logarithms can reduce the complexity of an equation from multiplication, down to addition, indicates its usefulness as a tool to *simplify* arithmetic problems. Specifically, the logarithm of a product is equal to the sum of the logarithms of the two numbers being multiplied.

---

Answer 8

Here I will show you the steps to using logarithms to solve the first multiplication problem:

$$7 \times 5 = ???$$

$$7 \times 5 = 10^{\log 7 + \log 5}$$

$$7 \times 5 = 10^{0.8451 + 0.6990}$$

$$7 \times 5 = 10^{1.5441}$$

$$7 \times 5 = 35$$

Since the others are easy enough for you to check (with your non-broken calculator!), I'll leave their solutions in your capable hands.

---

Answer 9

That logarithms can reduce the complexity of an equation from division, down to subtraction, indicates its usefulness as a tool to *simplify* arithmetic problems. Specifically, the logarithm of a quotient is equal to the difference between the logarithms of the two numbers being divided.

---

Answer 10

Here I will show you the steps to using logarithms to solve the first multiplication problem:

$$12 \div 3 = ???$$

$$12 \div 3 = 10^{\log 12 - \log 3}$$

$$12 \div 3 = 10^{1.0792 - 0.4771}$$

$$12 \div 3 = 10^{0.6021}$$

$$12 \div 3 = 4$$

Since the others are easy enough for you to check (with your non-broken calculator!), I'll leave their solutions in your capable hands.

---

Answer 11

That logarithms can reduce the complexity of an equation from exponentiation, down to multiplication, indicates its usefulness as a tool to *simplify* arithmetic problems. Specifically, the logarithm of a number raised to a power is equal to that power multiplied by the logarithm of the number.

---

Answer 12

Here I will show you the steps to using logarithms to solve the first multiplication problem:

$$3^4 = ???$$

$$3^4 = 10^{(4 \log 3)}$$

$$3^4 = 10^{(4)(0.4771)}$$

$$3^4 = 10^{1.9085}$$

$$3^4 = 81$$

Since the others are easy enough for you to check (with your non-broken calculator!), I'll leave their solutions in your capable hands.

---

Answer 13

That logarithms can reduce the complexity of an equation from fractional exponentiation, down to simple fractions, indicates its usefulness as a tool to *simplify* arithmetic problems. Specifically, the logarithm of a root of a number is equal to the logarithm of that number divided by the root index.

---

Answer 14

Here I will show you the steps to using logarithms to solve the first multiplication problem:

$$\sqrt[3]{8} = ???$$

$$\sqrt[3]{8} = 10^{(\frac{1}{3} \log 8)}$$

$$\sqrt[3]{8} = 10^{(\frac{1}{3}(0.9031))}$$

$$\sqrt[3]{8} = 10^{0.3010}$$

$$\sqrt[3]{8} = 2$$

Since the others are easy enough for you to check (with your non-broken calculator!), I'll leave their solutions in your capable hands.

---

Answer 15

- $10^{\log 3} = 3$
- $\log(10^8) = 8$
- $e^{\ln 3} = 3$
- $\ln(e^8) = 8$
- $10^{(\log 3 + \log 5)} = 15$
- $e^{(\ln 3 + \ln 5)} = 15$
- $10^{(\log 2.2 + \log 4)} = 8.8$
- $e^{(\ln 2.2 + \ln 4)} = 8.8$
- $10^{(\log 12 - \log 4)} = 3$
- $e^{(\ln 12 - \ln 4)} = 3$
- $10^{(2 \log 3)} = 9$
- $e^{(2 \ln 3)} = 9$
- $10^{(\frac{\log 25}{2})} = 5$
- $e^{(\frac{\ln 25}{2})} = 5$

---

Answer 16

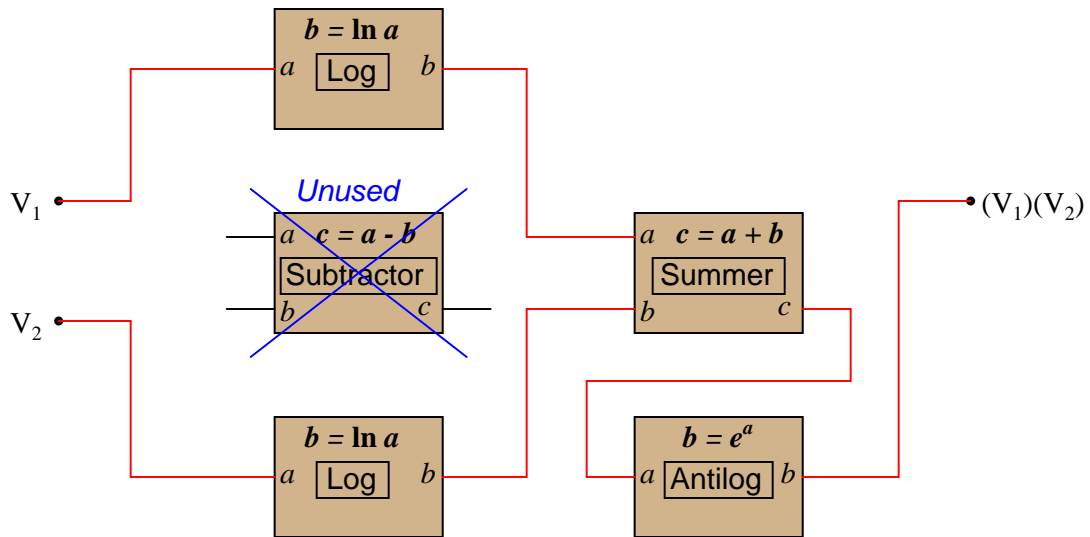

Notes 1

In my experience, most American students are woefully underprepared for the subject of logarithms when they study with me. Admittedly, logarithms do not see as much use in everyday life as powers do (and that is very little for most people as it is!). Logarithms used to be common fare for secondary school and college students, as they were essential for the operation of a *slide rule*, an elegant mechanical analog computing device popular decades ago.

The purpose of this question is twofold: to get students to realize what a logarithm is, and also to remind them of the concept of inverse functions, which become very important in analog computational circuits.

---

Notes 2

Nothing special here. Indeed, the answer to this question may be derived from any algebra textbook.

---

Notes 3

Some calculators, of course, allow you to extract the logarithm of any number to any base. Here, I simply want students to become familiar with the two logarithm functions available on the most basic scientific calculators.

Note that some calculators will show just enough digits of  $e$  to give the false impression that they repeat (ten digits:  $e = 2.718281828$ ). If anyone suggests that  $e$  is a (rational) repeating decimal number, correct this misunderstanding by telling them it is irrational just like  $\pi$ .

---

Notes 4

An illustration like this helps students comprehend what the "log" function actually does.

---

Notes 5

An illustration like this helps students comprehend what the "log" function actually does.

---

Notes 6

In this question, I want students to begin to see how logarithms relate multiplication to addition, and how powers relate addition to multiplication. This is an initial step to students recognizing logarithms as *transform functions*: a means to transform one type of mathematical problem into a simpler type of mathematical problem.

---

Notes 7

In mathematics, any procedure that reduces a complex type of problem into a simpler type of problem is called a *transform function*, and logarithms are one of the simplest types of transform functions in existence.

---

Notes 8

Incidentally, there is nothing special about the common logarithm to warrant its exclusive use in this problem. We could have just as easily applied the natural logarithm function with the same (final) result:

$$7 \times 5 = ???$$

$$7 \times 5 = e^{\ln 7 + \ln 5}$$

$$7 \times 5 = e^{1.9459 + 1.6094}$$

$$7 \times 5 = e^{3.5553}$$

$$7 \times 5 = 35$$

---

Notes 9

In mathematics, any procedure that reduces a complex type of problem into a simpler type of problem is called a *transform function*, and logarithms are one of the simplest types of transform functions in existence.

---

Notes 10

Incidentally, there is nothing special about the common logarithm to warrant its exclusive use in this problem. We could have just as easily applied the natural logarithm function with the same (final) result:

$$12 \div 3 = ???$$

$$12 \div 3 = e^{\ln 12 - \ln 3}$$

$$12 \div 3 = e^{2.4849 - 1.0986}$$

$$12 \div 3 = e^{1.3863}$$

$$12 \div 3 = 4$$

---

Notes 11

In mathematics, any procedure that reduces a complex type of problem into a simpler type of problem is called a *transform function*, and logarithms are one of the simplest types of transform functions in existence.



---

Notes 12

Incidentally, there is nothing special about the common logarithm to warrant its exclusive use in this problem. We could have just as easily applied the natural logarithm function with the same (final) result:

$$3^4 = ???$$

$$3^4 = e^{(4 \ln 3)}$$

$$3^4 = e^{(4)(1.0986)}$$

$$3^4 = e^{4.3944}$$

$$3^4 = 81$$

---

Notes 13

In mathematics, any procedure that reduces a complex type of problem into a simpler type of problem is called a *transform function*, and logarithms are one of the simplest types of transform functions in existence.

---

Notes 14

Incidentally, there is nothing special about the common logarithm to warrant its exclusive use in this problem. We could have just as easily applied the natural logarithm function with the same (final) result:

$$\sqrt[3]{8} = ???$$

$$\sqrt[3]{8} = e^{(\frac{1}{3} \ln 8)}$$

$$\sqrt[3]{8} = e^{(\frac{1}{3})(2.0794)}$$

$$\sqrt[3]{8} = e^{0.6931}$$

$$\sqrt[3]{8} = 2$$

---

Notes 15

Discuss what mathematical operations are being done with the constants in these equations, by using logarithms. What patterns do your students notice? Also, discuss the terms "log" and "antilog," and relate them to opamp circuits they've seen.

Ask your students whether or not they think it matters what "base" of logarithm is used in these equations. Can they think of any other arithmetic operations to try using logarithms in this manner?

---

Notes 16

The purpose of this question is simple: to provide a practical application for logarithms as computational aids in an age of cheap, ubiquitous, digital computing devices.