

Introduction

Altera® devices combine unique programmable logic architectures with advanced CMOS processes to provide exceptional performance and reliability. To maintain the highest possible performance and reliability of Altera devices, system designers must consider the following operating requirements:

- Operating conditions
- Pin voltage levels
- Output loading
- Power-supply management
- Device programming/erasure

Operating Conditions

When Altera devices are implemented in a system, they are rated according to a set of defined parameters. These parameters are provided in each device family data sheet and include absolute maximum ratings, recommended operating conditions, and DC and AC operating conditions.

Absolute Maximum Ratings

Absolute maximum ratings define the maximum operating conditions for a particular Altera device. These values are based on experiments conducted with Altera devices, and on theoretical modeling of breakdown and damage mechanisms. These ratings are stress ratings only. The functional operation of Altera devices is not implied at these conditions or at conditions beyond those indicated in the "Recommended Operating Conditions" tables in device family data sheets. For example, I_{OUT} is the absolute current capacity, not the drive capability of an output pin. The output drive characteristics are given as I_{OH} and I_{OL} in the "DC Operating Conditions" table of each device family data sheet.

Device reliability can be impaired if an Altera device operates for extended periods of time at conditions listed in the "Absolute Maximum Ratings" table in each device family data sheet. Operating the device at conditions that exceed these ratings can permanently damage the device.

Recommended Operating Conditions

The functional operation limits for an Altera device, listed in the “Recommended Operating Conditions” table in each device family data sheet, specify limits for all DC and AC parameters. These parameters are expressed differently in other rating sections. For example, the V_{CC} range specified in the “Recommended Operating Conditions” table is the voltage range for safe device operation, while the V_{CC} range specified in the “Absolute Maximum Ratings” table is the power-supply level beyond which the device can be permanently damaged.

DC Operating Conditions

The steady-state voltage and current values expected from Altera devices are provided in the “DC Operating Conditions” table of each device family data sheet. This information includes input voltage sensitivities (V_{IH} and V_{IL}), output voltage (V_{OH} and V_{OL}), current drive characteristics (I_{OH} and I_{OL}), and input and output leakage currents (I_I and I_{OZ}).

AC Operating Conditions

The internal and external timing parameters for an Altera device are listed in the “AC Operating Conditions” table in each device family data sheet. These parameters are determined under the conditions specified in the “Recommended Operating Conditions” table. The internal timing parameters are the delays associated with specific architectural features. Device performance can be estimated by following the signal path from a source to the destination and adding the appropriate internal timing parameters. The external timing parameters are specified as pin-to-pin delays when the device is operating under these conditions.

Timing parameters are specified as maximum, minimum, or typical values. A maximum value indicates that the delay will not exceed the specified time. Setup, hold, memory cycle, and pulse width times are expressed as minimum values that the system must provide to ensure reliable device operation. Expected values based on device characteristics are expressed as typical values; actual values can vary.

Pin Voltage Levels

Device pins can be exposed to dangerous voltages during handling or device operation. During handling, pins can be exposed to high-voltage static discharges that cause electrostatic discharge (ESD) damage. During operation, power-supply spikes on the V_{CC} and GND pins or errant logic levels elsewhere in the system can produce logic-level stress with voltages similar to V_{CC} (0 V to 15 V). To minimize these hazards, the user must observe the precautions specified for the following conditions:

- Pin connections
- Latch-up
- Hot-socketing
- ESD

Pin Connections

During project compilation, the MAX+PLUS® II Compiler generates a device utilization report, called a Report File (.rpt). The Report File provides information on the pin-outs and connectivity of the device(s) used in the project. The Report File also includes a pin-out diagram that shows the user power, ground, dedicated function, and unused pins.

The power and ground pins should be tied to the V_{CC} or ground planes, respectively, on the printed circuit board (PCB). Dedicated input pins used in a design and I/O pins configured as inputs should always be driven by an active source. I/O pins configured as bidirectional pins should always be driven whenever the I/O pin is used as an input. Unused dedicated input and I/O pins are marked in the Report File as GND and RESERVED, respectively. Unused dedicated inputs should be tied to the ground plane. Otherwise, these pins may “float” in an indeterminate state, possibly increasing DC current in the device and introducing noise into the system. To prevent floating, unused I/O pins are driven by an internal signal and are reported as RESERVED. All RESERVED I/O pins should remain unconnected. Tying a RESERVED I/O pin to V_{CC}, ground, or another signal source can create contention that can damage the output driver on the device.

Some Altera devices include the MultiVolt™ feature, which allows devices to interface with multiple voltage systems. These devices may have separate V_{CCIO} (I/O power) and V_{CCINT} (internal power) pins. Refer to individual device data sheets for limits on V_{CCIO} and V_{CCINT} voltage ranges.

For proper operation, signals on the input and output pins must be in the following range:

$$\text{Ground} \leq (V_{\text{IN}} \text{ or } V_{\text{OUT}}) \leq V_{\text{CCINT}}$$

Some devices can accept V_{IN} that is greater than V_{CCINT} . Refer to individual device data sheets for specific voltage limitations.

If a design connects GND_{INT} and GND_{IO} to different ground planes, GND_{INT} and GND_{IO} must always be within 1.0 V. Otherwise, devices may operate incorrectly.

Latch-Up

Parasitic bipolar transistors, which are present in the fundamental structure of CMOS devices, can create paths in the device for destructive currents. Typically, the base-emitter and base-collector junctions of these parasitic transistors are not forward-biased, so they are not turned on. Figure 1 shows a cross-section of a CMOS wafer and primary parasitic transistors (labeled Q1 and Q2). To ensure that all junctions remain reverse-biased, the P-type substrate is connected to the most negative voltage available on the device (ground), and the N-type well structure is connected to the most positive voltage on the device (V_{CC}). Figure 1 also shows the parasitic resistors (labeled R1 and R2) that occur in the CMOS structure.

Figure 1. Parasitic Bipolar Transistors in CMOS Devices

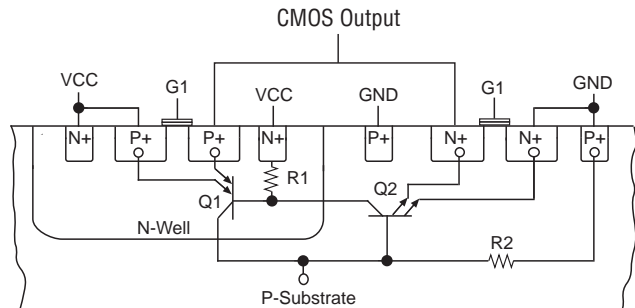

Catastrophic failure can occur if these parasitic structures begin to conduct, because the effect is regenerative and reinforces itself until potentially destructive currents are produced. The two parasitic transistors combine to form a silicon-controlled rectifier (SCR). The latch-up effect occurs when the SCR is turned on, resulting in high current flow through the CMOS device.

The SCR can be turned on by transients occurring on the gates of the CMOS device or on the output of the CMOS device. Because I/O pins are connected to the input and output buffers, latch-up can occur on either buffer.

If the I/O pad is driven above V_{CCINT} or below ground, latch-up may occur.



Most 3.3-V, 2.5-V, and 1.8-V devices, such as APEX™ 20K, FLEX 10KE, FLEX® 10KA, MAX® 7000A, and MAX 3000A devices, are designed to withstand input voltages above V_{CCINT} . However, there is a level at which the device may be damaged. Refer to the device data sheets for specifications.

When the output pad is driven below ground, Q2 will turn on as its emitter becomes more negative than its base. This effect causes Q1 to turn on as its base becomes more negative than its collector. The current flow through Q1 causes Q2's base to become more positive (due to the voltage drop over parasitic resistor R2). The current flow through Q2 causes Q1's base to become more negative (due to the voltage drop over parasitic resistor R1). Both current flows cause Q1 and Q2 to conduct more current in a regenerative effect. As the current flows through the parasitic transistors, the voltage drops through the increase in the resistor. Once started, the cycle continues until the device is powered down or damaged by high current flow.

When the input buffer pad is driven below ground, current is injected into the substrate via the diffused ESD protection resistor (see “[Electrostatic Discharge](#)” on page 6). This current can raise Q2's voltage level, starting the latch-up cycle. Again, the cycle continues until the device is powered down or damaged by high current flow.

Conversely, if the I/O pad is driven above V_{CC} , Q1 will turn on as its emitter is driven higher than its base. The same regenerative effect occurs as in the undershoot case.

The I/O pad may be driven outside of V_{CC} and ground due to signal ringing, undershoot, or overshoot. The board should be designed to minimize these effects to prevent latch-up.

Altera devices have been designed to minimize the effects of latch-up that are caused by power-supply and I/O pin transients. Under recommended operating conditions, all devices can withstand input voltage extremes, as shown in the device data sheets, as well as input currents of 100 mA or less that are forced through the device pins. Furthermore, low-voltage devices are designed to withstand input voltages above V_{CCINT} .



To minimize the chances of inducing latch-up during power-up, ground should be applied to the device first, then V_{CCINT} and V_{CCIO} , and finally the inputs. The power should be removed from the device in the reverse order: the inputs are removed first, then V_{CCINT} and V_{CCIO} , and finally ground. Some device inputs may be driven before powering V_{CCINT} and V_{CCIO} . Consult the individual device data sheets for details.

Simultaneous application of inputs V_{CCINT} and V_{CCIO} to the device, which can occur as the power supply rises during power-up, should be safe as long as V_{CCINT} and V_{CCIO} meet the maximum rise time. The designer should ensure that the inputs cannot rise faster than the power supply at the V_{CCINT} and V_{CCIO} pins.

Hot-Socketing

Contention may occur when electrical subsystems are “hot-socketed” or plugged into active hardware. When a subsystem is hot-socketed, the logic levels often appear at the subsystem’s logic devices before the power supply can provide current to the V_{CC} and ground grid of the subsystem board. This condition can lead to contention between the device and the backplane.

Increasing the length of the V_{CC} and ground connections can reduce the chances of contention during hot-socketing. If metal “fingers” are used for the board connection, the V_{CC} and ground fingers at the card edge should be longer than the logic connections. The difference in length causes the power supply to appear at the device before the logic levels, which is usually sufficient to prevent contention. Off-the-shelf connectors with longer V_{CC} and ground connections can provide similar results.

Specific Altera devices are designed to accommodate hot-socketing with no special design precautions. Refer to individual device data sheets for more information on hot-socketing.

Electrostatic Discharge

Electrostatic discharge (ESD) resulting from improper device handling can cause device failure that may manifest itself in the following ways:

- Immediate functional failure
- Degraded I/O performance
- Decreased long-term reliability

Handling devices during the programming cycle increases exposure to potential static-induced failure. Synthetic materials used in clothing can store large amounts of static electricity, which can cause ESD. During normal activity, the human body can generate voltages of up to tens of kilovolts (kV). Therefore, to reduce the likelihood of ESD damage, users should wear ground straps when handling devices and ground all surfaces that contact devices.

Altera devices include special structures that reduce the effects of ESD on the pins. [Figure 2](#) shows a typical input structure for an Altera device. Diode structures and an output buffer shunt harmful voltages to ground before the circuitry can be damaged. ESD performance data is reported in Altera’s reliability reports.

Figure 2. Altera Device Input Protection Structures

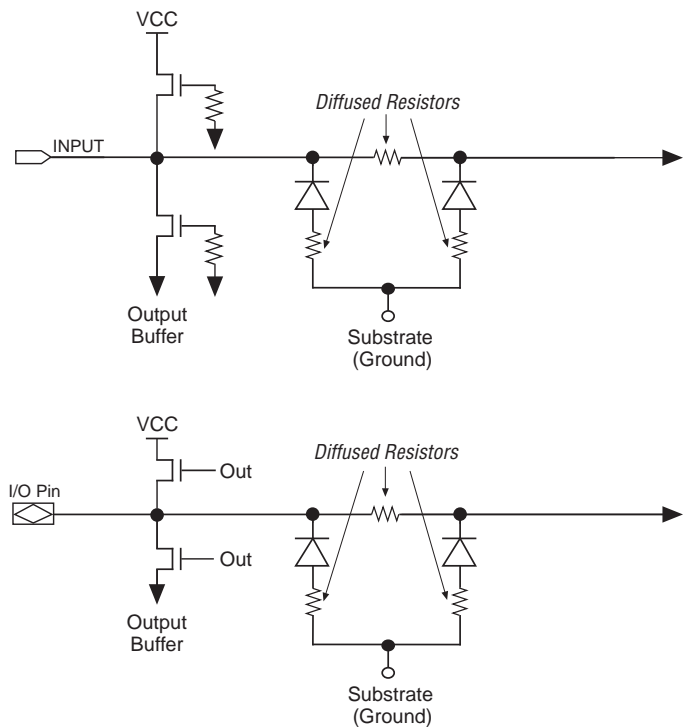

Output Loading

Output loading is typically resistive and/or capacitive. During development, the designer should ensure that the target device can supply both the current and speed necessary for the loads.

Resistive Loading

Resistive loading exists whenever a device output sinks or sources a current in a steady state (e.g., devices with TTL inputs, terminated buses, and discrete bipolar transistors).

Output drive characteristics (I_{OH} and I_{OL}), which are functions of output voltages (V_{OH} and V_{OL}), are listed in each device family data sheet. Under DC conditions, the output current capabilities determine the minimum resistance of a load while still maintaining the necessary output voltage. If the system requires higher currents, such as those necessary to drive an LED or a relay, a high-current buffer or a discrete current switch must be used.

Short-circuit conditions—where I_{OH} and I_{OL} exceed the absolute maximum rating (I_{OUT})—can permanently damage the device.

Capacitive Loading

The “AC Operating Conditions” table in each device family data sheet specifies an output capacitance condition (C1) for parameters relating to external performance. For most Altera devices, C1 is 35 pF for active signals and 5 pF for disabling output buffers.

Device packages and board-level trace capacitance contribute the majority of loading capacitance. The specified 35-pF load condition is a representative value for most CMOS circuits. For applications in which a device drives a higher capacitance, performance decreases as the capacitive load increases.

Device sockets are a source of both capacitive and inductive loading. Once a system is finalized for production, sockets should be removed if possible, and the devices should be mounted directly onto the PCB. Direct board mounting reduces both the capacitive and inductive loads as well as noise from socket contacts.

To ensure the highest circuit performance, the capacitance on device outputs should be minimized. Wiring traces on the PCB, device input pins, and device packaging all contribute to the total capacitance; therefore, the following guidelines should be observed:

- Board layout should ensure that signals run perpendicular to each other to provide a minimum capacitive coupling effect. Also, signal traces should be kept as short as possible.
- A high-current buffer should be used to speed the signal to all destinations for networks in which a single source drives many loads.

The lack of V_{CC} and ground planes or excessive trace lengths can cause problems with radiated coupling of noise into logic signals and with transmission-line effects on signal quality. These ringing and noise elements on logic levels can lead to circuit reliability problems. When recommended layout practices cannot be implemented to prevent transmission-line problems, a small series resistor (10 Ω to 30 Ω) can be used to reduce the undershoot or overshoot magnitude on signal edges. This resistor dampens the ringing that can occur on long board traces and prevents false triggering.



For more information, see [Application Note 75 \(High-Speed Board Designs\)](#).

Power-Supply Management

Although Altera devices are designed to minimize noise generation and susceptibility, they can be sensitive to fluctuations in power supply and input lines, like all CMOS devices.

To minimize the effect of these fluctuations, the system designer must pay special attention to the following factors:

- V_{CC} and ground planes
- Decoupling capacitors
- V_{CC} rise time
- Current dissipation

V_{CC} & Ground Planes

The system designer can minimize power-supply noise or “ground bounce” by providing separate V_{CC} and ground planes for every PCB, thus ensuring a large current-sink capability, noise protection, and shielding for logic signals on the board. If an entire plane cannot be provided, the widest possible ground and V_{CC} traces should be created throughout the entire board. Logic-width traces should not be used to carry the power supply. Although V_{CC} and ground planes tend to increase the capacitive load of the traces, they significantly reduce system noise and dramatically increase system reliability.

Decoupling Capacitors

Each V_{CC} and GND pin should be connected directly to the V_{CC} and ground planes of the PCB. Decoupling requirements are based on the amount of logic used in the device and the output switching requirements. As the number of I/O pins and the capacitive load on the pins increase, more decoupling capacitance is required. As many as possible 0.2- μ F power-supply decoupling capacitors should be connected to the V_{CC} and GND pins or the V_{CC} and GND planes. These capacitors should be located as close as possible to the Altera device. When using a device with separate V_{CCINT} and V_{CCIO} pins, each V_{CCIO}/GNDIO and V_{CCINT}/GNDINT pair should be decoupled with a 0.2- μ F capacitor. When using high-density packages, such as ball-grid array (BGA) packages, it may not be possible to use one decoupling capacitor per V_{CC}/GND pair. In this case, you should use as many decoupling capacitors as possible. Devices with separate V_{CCINT} and V_{CCIO} pins, but not separate GNDIO and GNDINT pins, should be decoupled with capacitors from V_{CCIO} and V_{CCINT} to ground. For less dense designs, a reduction in the number of capacitors may be acceptable. Decoupling capacitors should have a good frequency response, such as monolithic-ceramic capacitors.

Each PCB should also have a large-capacity, general-purpose, electrolytic capacitor network to stabilize the power supply. A 100- μ F capacitor should be placed immediately adjacent to where the power-supply lines come into the PCB. If a transformer or regulator is used to change the voltage level, the capacitor should be placed immediately after the final stage that develops the device’s power supply. This capacitor provides a beneficial leveling effect that supplies extra current when a large number of nodes switch simultaneously in a circuit. However, the larger the power supply capacitor, the longer the time required to bring the maximum V_{CC} to the operating level. The size of the capacitor must not cause the V_{CC} rise time to violate the maximum rise time.

V_{CC} Rise Time

When power is applied to an Altera device, the device initiates a Power-On Reset (POR) event, typically as V_{CC} approaches 1.0 V to 2.0 V. The POR event does not exceed 100 ms and occurs only if V_{CC} reaches the recommended operating range within a certain period of time (specified as a maximum V_{CC} rise time). Slower rise times can cause incorrect device initialization and functional failure. The power supply voltage should rise monotonically to its recommended V_{CC} level. The maximum V_{CC} rise times for Altera devices are provided in the “Recommended Operating Conditions” section of each device family data sheet.

For MAX devices, the POR time is the time required after V_{CC} reaches the recommended operating range to clear device registers, configure I/O pins, and release tri-states. Once this initialization is complete, the device is ready to begin logic operation. For MAX devices, the POR time does not exceed 50 ms.

For FLEX and APEX devices, the POR time is the time required after V_{CC} reaches the recommended operating range to clear the device, prepare for configuration, and release the $nSTATUS$ pin. Once the $nSTATUS$ pin is released, the device is ready for configuration. On FLEX 8000 devices, the POR does not exceed 100 ms. For other FLEX and APEX devices, the POR time does not exceed 5 μ s.

For EPC1441, EPC1, and EPC2 configuration devices, the POR time is the time required after V_{CC} reaches the recommended operating range to release the OE pin and start configuration. On these devices, the POR time does not exceed 200 ms.

Current Dissipation

Each Altera device is designed to consume a minimal amount of power while providing high performance. Because these two design goals can conflict, Altera devices and software tools allow designers to monitor and control the current with built-in device features.

Each MAX 9000, MAX 7000, and MAX 3000A device macrocell can be configured for either high performance or low power consumption during design entry. Turning on the macrocell’s Turbo Bit™ option allows the macrocell to function in a high-performance mode at the specified device ratings. If the Turbo Bit option is turned off, the macrocell’s built-in power-saving mode trades higher performance for lower current consumption.

MAX 9000, MAX 7000, and MAX 3000A devices operating in low-power mode consume less current. The supply current (I_{CC}) can be reduced by approximately 50%, depending on the design and operating frequency. I_{CC} vs. frequency graphs are provided in the *MAX 9000 Programmable Logic Device Family Data Sheet*, *MAX 7000A Programmable Logic Device Family Data Sheet*, *MAX 7000 Programmable Logic Device Family Data Sheet*, and *MAX 3000A Programmable Logic Device Family Data Sheet*. For a device with the Turbo Bit option, the graph provides two curves: one showing I_{CC} versus frequency when all macrocells have their Turbo Bits turned on, and the other with all Turbo Bits off. Because most designs use a combination of turbo and non-turbo macrocells, a formula that accounts for this ratio and the frequency of operation is also provided with the graph. The values shown in the graph and formula are measured with no output loads and represent only the current consumed by device operation.

Many Classic™ devices also have a Turbo Bit option. A Classic device operating in low-power mode enters a standby mode after 100 ns of inactivity (i.e., when no inputs or outputs have changed). An input signal transition “wakes” the device, which then performs normally until the next standby mode period. However, the input signal incurs an additional delay—specified as the non-turbo delay adder in device family data sheets—as it wakes and propagates through the device.

Device Programming/ Erasure

MAX 9000, MAX 7000, MAX 3000A, Classic, and configuration devices use non-volatile, reprogrammable EPROM, EEPROM, or FLASH memory elements to retain configuration data. Therefore, configuration data does not need to be reloaded when the system powers up. EPROM and EEPROM memory elements share similar programming characteristics, but different erasure mechanisms.

All Altera EEPROM and FLASH-based devices are reprogrammable. EEPROM and FLASH elements are electrically erasable and therefore do not have an erasure window. EEPROM and FLASH-based devices are erased automatically immediately before being programmed, and can be reprogrammed at least 100 times. Most devices can be reliably reprogrammed many more times beyond this specified minimum. During programming, the EEPROM or FLASH cell does not require a special V_{PP} pin with a higher programming voltage. The only exception is the EPC2 configuration device, which can have its V_{PP} pin driven at 5.0 V when the device is operating at 3.3 V. This can be done to improve programming time. The device generates the required voltage internally.

Altera's EPROM-based devices are available in both plastic and ceramic packages. EPROM devices in plastic packages are one-time-programmable (OTP) devices; windowed ceramic packages are erased when exposed to UV light. Altera EPROM-based devices begin to erase when exposed to lights with wavelengths shorter than 4,000 Å. Because fluorescent lighting and sunlight fall into this range, an opaque label must be placed over the device window to ensure long-term reliability. To erase a device completely, it must be exposed to UV light with a wavelength of 2,540 Å. Devices should be erased for one hour by an eraser system with a power rating of 12,000 $\mu\text{W}/\text{cm}^2$. Altera devices can be damaged when exposed to UV light for longer than one hour.

Altera EPROM-based devices can be programmed and erased at least 25 times, provided that the recommended erasure exposure levels are followed. However, most devices can be reliably erased and reprogrammed many more times beyond this specified minimum.

Information contained in the *Operating Requirements for Altera Devices Data Sheet* version 9.02 supersedes information published in previous versions.

Revision History

Version 9.02 Changes

Version 9.02 contains the following changes:

- Updated electrostatic discharge information on [page 7](#).
- Updated V_{CC} rise time information on [page 11](#).
- Made minor text changes throughout the document.
- Updated note on [page 5](#) to reflect 1.8-V APEX 20K device information.

Version 9.01 Changes

Version 9.01 contained updated POR timing information in "V_{CC} Rise Time" on [page 11](#).



101 Innovation Drive
San Jose, CA 95134
(408) 544-7000
<http://www.altera.com>
Applications Hotline:
(800) 800-EPLD
Customer Marketing:
(408) 544-7104
Literature Services:
(888) 3-ALTERA
lit_req@altera.com

Altera, APEX, APEX 20K, MAX, MAX+PLUS, FLEX, MAX+PLUS II, Classic, MAX, MAX 9000, MAX 7000, MAX 7000A, TurboBit, MAX 5000, MAX 3000A, FLEX 10KE, and FLEX 10K. Altera acknowledges the trademarks of other organizations for their respective products or services mentioned in this document. Altera products are protected under numerous U.S. and foreign patents and pending applications, maskwork rights, and copyrights. Altera warrants performance of its semiconductor products to current specifications in accordance with Altera's standard warranty, but reserves the right to make changes to any products and services at any time without notice. Altera assumes no responsibility or liability arising out of the application or use of any information, product, or service described herein except as expressly agreed to in writing by Altera Corporation. Altera customers are advised to obtain the latest version of device specifications before relying on any published information and before placing orders for products or services.

Copyright © 1999 Altera Corporation. All rights reserved.



I.S. EN ISO 9001