

ADPCM Megafunction

Solution Brief 8

December 1996, ver. 1

Target Applications:

Communications
Digital Signal Processing

Family: FLEX 10K

Vendor:



Integrated Silicon Systems, Ltd.

29 Chlorine Gardens

Belfast, BT9 5DL,

Northern Ireland

Tel. 44 1232-664-664

Fax 44 1232-669-664

E-mail Info@ISS-DSP.com

WWW <http://www.ISS-DSP.com>

Features

- Fully compliant with G.721, G.723, G.726, G.726a, G.727, and G.727a CCITT standards
- Parameterized number of duplex channels
- Supports both A- and μ -law pulse code modulation (PCM) coding and 5-, 4-, 3-, and 2-bit coding rates
- Optimized for the FLEX[®] 10K device architecture
- Supports up to 16 full duplex channels, 32 encode channels, or 32 decode channels
- Ideal for a variety of applications
 - Digital circuit multiplication equipment (DCME) overload voice channels
 - DCME data modem signals
 - Packetized speech systems

General Description

The adaptive pulse code modulation (ADPCM) megafunction performs multi-channel duplex ADPCM coding in telecommunications applications. Most of the applications of the G.726 standard are in overload channel communication, i.e., carrying voice and data modem signals in DCME, particularly for modems operating in excess of 4,800 kbits per second. Most of the applications of the G.727 standard are in converting A- and μ -law PCM channels to and from variable-rate embedded ADPCM channels. The primary use of the megafunction in the G.727 and G.726 standard is for packetized speech systems, operating in accordance with the packetized voice protocol (PVP).

The ADPCM megafunction, which is optimized for the Altera[®] FLEX 10K architecture, combines the algorithm and architecture research of ISS with the performance and implementation advantages of the FLEX 10K family. The ADPCM megafunction is designed in a hierarchical manner to enable the high-quality implementation achieved in the lower-level blocks, such as multipliers and adders, to be carried through to the higher-level encoder and decoder blocks.

The megafunction ensures that products incorporating ADPCM can be delivered to market quickly and efficiently, and is parameterized to meet the target application operating requirements. The megafunction can be utilized for multi-channel encoding, multi-channel decoding, and multi-channel duplex coding. See [Figures 1 and 2](#).

Figure 1. ADPCM Encoder Block Diagram

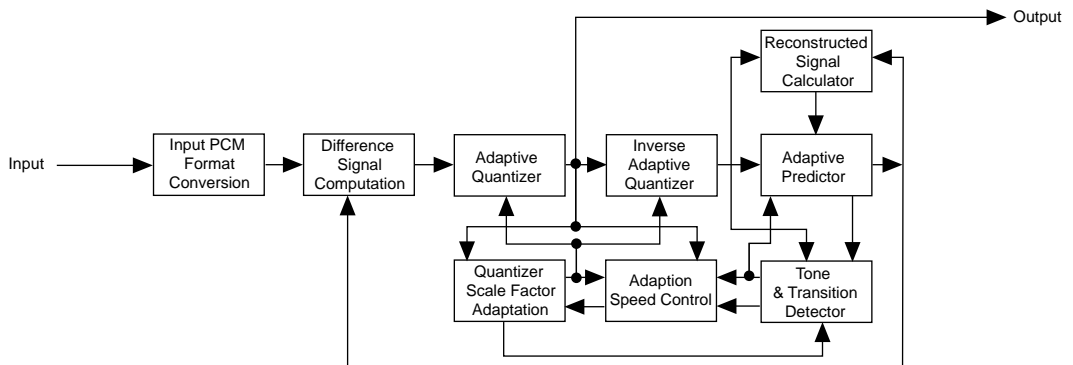
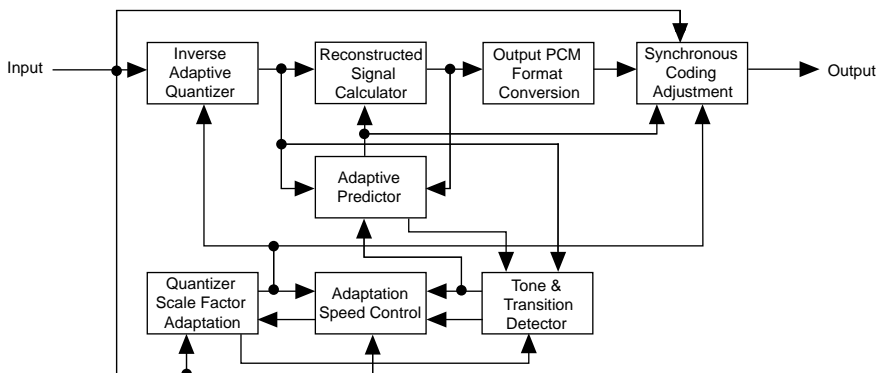

Figure 2. ADPCM Decoder Block Diagram



Coding Rates & Standards

The ADPCM megafunction supports:

- All four coding rates (5-, 4-, 3-, and 2-bit), six CCITT standards (G.721, G.723, G.726, G.726a, G.727, G.727a), and both A- and μ -law PCM formats
- Single coding rates and standards
- Multiple coding rates and standards

When instantiating the ADPCM megafunction, the control bits can be used to select the desired coding rate. Depending on the coding rate selected, the function may use less logic. The Altera MAX+PLUS® II software will automatically minimize the design, removing any unused logic.

The G.726 standard is a fixed ADPCM algorithm for conversion to and from 64 kbits per second and 40, 32, 24, and 16 kbits per second. The algorithms of the G.727 standard quantize the signal into core and enhancement bits. The core bits are used for precision while the enhancement bits are used to reduce the quantization noise in the reconstructed signal. The core bits must reach the decoder, but the enhancement bits can be discarded to alleviate congestion. (The G.726a and G.727a represent modifications to the standards.)

Performance & Utilization

Table 1 shows the performance and typical utilization of the ADPCM megafunction.

Table 1. ADPCM Performance & Utilization (for a EPF10K100-3 device)				
Function	Speed	Architecture	Logic Cells	EABs
16-channel full-duplex ADPCM, covering all 6 CCITT Standards	5.12 MHz	FLEX 10K	3,963	5



2610 Orchard Parkway
 San Jose, CA 95134-2020
 (408) 894-7000
<http://www.altera.com>

Copyright © 1996 Altera Corporation. Altera, AMPP, MAX+PLUS, MAX+PLUS II, FLEX, and FLEX 10K are trademarks and/or service marks of Altera Corporation in the United States and other countries. Other brands or products are trademarks of their respective holders. The specifications contained herein are subject to change without notice. Altera assumes no responsibility or liability arising out of the application or use of any information, product, or service described herein except as expressly agreed to in writing by Altera Corporation. Altera customers are advised to obtain the latest version of device specifications before relying on any published information and before placing orders for products or services. All rights reserved.