

Binary Pattern Correlator Megafunction

Solution Brief 18

April 1997, ver. 1

Target Applications:

Wireless Communications
Digital Signal Processing

Family: FLEX 10K & FLEX 8000

Vendor:



Nova Engineering, Inc.
5 Circle Freeway Drive
Cincinnati, OH 45246
USA
Tel. (513) 860-3456
Fax (513) 860-3535
E-mail info@nova-eng.com
WWW <http://www.nova-eng.com>

Features

- Optimized for the FLEX® 10K and FLEX 8000 device architectures
- Parallel correlation summing network for maximum speed
- Programmable reference pattern and mask registers
- Cascadable in length and depth
- Applications include:
 - Frame synchronization
 - Spread-spectrum receivers
 - Error correction
 - Pattern matching

General Description

The binary pattern correlator megafunction is a digital correlator that compares the digital pattern stored in the reference pattern register with the data samples stored in the correlator shift register. The megafunction contains the following components: a data shift register, a reference pattern register, a mask register, the correlation array, and the correlation summing network. Figure 1 shows a block diagram of the binary pattern correlator megafunction.

Figure 1. Binary Pattern Correlator Megafunction Block Diagram

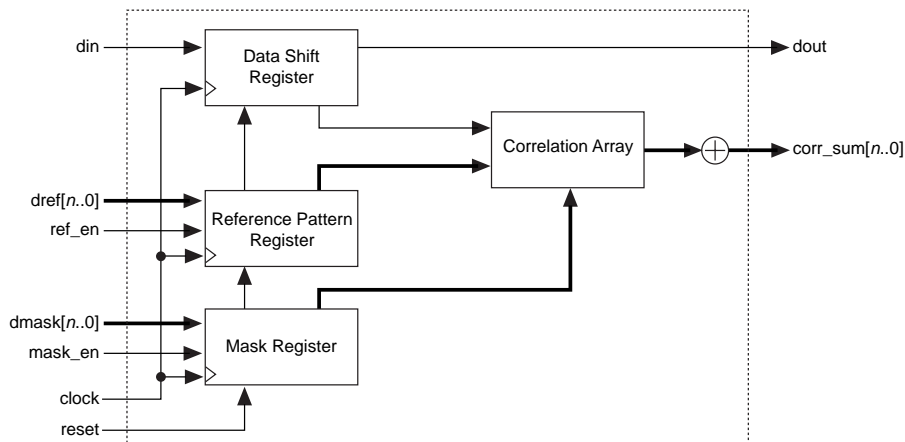

Functional Description

To determine the number of matches in a data stream, the megafunction shifts the data samples into the data shift register, where they are compared with the data stored in the reference pattern register. The number of matches is calculated on each rising edge of the clock, and the final sum is referred to as the correlation sum.

Typically, the correlation sum is compared to a programmable threshold. The threshold determines the probability of detection and the false alarm rate. A lower threshold increases the probability of a detection, but it can also increase the probability of a false alarm. For example, if the shift register and reference pattern are 32 bits in length, then a threshold setting of 32 requires a perfect match with no false alarms. However, a threshold of 32 does not permit a single bit error. Most systems are required to be tolerant of a small number of errors. Therefore, a threshold of 31 provides a bit error tolerance of about 3%. Although the probability of detection increases, the probability of a false alarm increases as well.

Ports

Table 1 describes the binary pattern correlator megafunction ports.

Table 1. Binary Pattern Correlator Megafunction Ports			
Name	Type	Size (Bits)	Description
din	Input	1	Serial or sampled data input.
dref[n..0]	Input	8 to 32	Reference pattern register input.
ref_en	Input	1	When high, the reference pattern register can load data.
dmask[n..0]	Input	8 to 32	Mask register input.
mask_en	Input	1	When high, the mask register will load data.
clock	Input	1	System clock.
reset	Input	1	Asynchronous reset, active high.
dout	Output	1	Serial data output from the most significant bit (MSB) of the register.
corr_sum[n..0]	Output	3 to 6	Indicates the number of matches between the shift register and the reference pattern register. The sum excludes the masked data bits.

Parameters

Nova Engineering will customize the megafunction's shift register, mask register, and reference pattern register lengths to meet user specifications. Customizing the megafunction requires no additional cost as long as it is within the parameters described in Table 2. The binary pattern correlator megafunction can also be cascaded in length or depth to form specific and diverse architectures.

Table 2. Binary Pattern Correlator Megafunction Parameters		
Name	Typical Values (Bits)	Customization
Shift register length	8 to 32	Customizable length.
Reference pattern register length	8 to 32	Customizable length.
Mask register length	0 to 32	Customizable length. The register can also be eliminated to conserve logic.
Correlation sum	3 to 6	Customizable bit width.

Performance

The binary pattern correlator megafunction is designed for both FLEX 10K and FLEX 8000 device architectures. The megafunction performs well in both device families and does not require the use of FLEX 10K embedded array blocks (EABs). Table 3 summarizes the maximum clock frequency and device utilization for the megafunction.

Implementation	Clock (f_{MAX})	Logic Cells	EABs
Input data width = 1 bit Shift register length = 32 bits Reference register length = 32 bits Mask register length = 32 bits	40 MHz	206	0

Applications

The binary pattern correlator megafunction can be used in the following applications: frame synchronization patterns, spread spectrum receivers, error correction, and pattern matching. The frame synchronization and error correction applications for the megafunction are discussed below.

Frame Synchronization Patterns

Frame synchronization patterns are used to indicate the beginning and/or end of a data frame. In a typical digital communication system, the receiver searches the demodulated serial data stream for a synchronization pattern. Detecting a frame synchronization pattern establishes the frame boundary, and subsequently, aligns the receiver frame timing to the transmitter frame timing.

This technique of detecting frame synchronization patterns is useful in burst communication protocols such as time division multiplexing (TDM), in which a central node can rapidly acquire and lock data bursts that are transmitted from multiple sources—even when the sources have different frame and bit timing. The central node searches the received data stream for a synchronization pattern, and it also estimates a transmitter's bit timing when the received data is over-sampled. The central node can immediately determine the transmitter's frame and bit timing, allowing it to receive data from a multitude of transmitters.

Error Correction

Digital communication systems typically encode binary data to reduce the probability of a bit error at the receiver. First, a data set is encoded into an orthogonal codeword. In this case, orthogonal means that the cross correlation between the codewords is 0. For example, if a data set has 000, 001, 010, 011, 100, 101, 110, 111, and the corresponding orthogonal codeword set has 00000000, 00110011, 01010101, 01100110, 00001111, 01011010, 00111100, 01101001, the cross correlation between the codewords is 0. Since the auto-correlation of any codeword is the maximum number of bits, the auto-correlation peak of this example is eight.

The transmitter encodes every three bits into its corresponding orthogonal codeword. At the receiver, the demodulated signal is routed to eight simultaneous correlators. Each correlator compares the received data to one of the eight possible codewords. The correlator with the largest correlation sum indicates the best match for the received data.

As an example, the binary pattern correlator megafunction can transmit a data symbol of 111 with a 12.5% bit error rate. Before transmission, the data symbol of 111 was encoded into the codeword 01101001. A noisy channel may have introduced a single bit error (i.e., one out of eight bits), which may account for the 12.5% bit error rate. The megafunction determines that the received codeword could be 01101000. Simultaneous correlation of the received codeword with all eight possible codewords will produce a correlation sum of +3 or -5 for all codewords except one. The codeword 01101001 produces a correlation sum of +7, which indicates the transmitted symbol is probably 111.



2610 Orchard Parkway
San Jose, CA 95134-2020
(408) 544-7000
<http://www.altera.com>

Copyright © 1997 Altera Corporation. Altera, AMPP, FLEX, FLEX 10K, and FLEX 8000 are trademarks and/or service marks of Altera Corporation in the United States and other countries. Other brands or products are trademarks of their respective holders. The specifications contained herein are subject to change without notice. Altera assumes no responsibility or liability arising out of the application or use of any information, product, or service described herein except as expressly agreed to in writing by Altera Corporation. Altera customers are advised to obtain the latest version of device specifications before relying on any published information and before placing orders for products or services. All rights reserved.