

# Implementing ATM Switch with APEX Embedded CAM

## Introduction

Content addressable memory (CAM) can accelerate the performance of any application that requires faster searches of its databases, lists, or patterns. A CAM application example is in the asynchronous transfer mode (ATM) switching networks. CAM can be used to accelerate VCI/VPI translation tables in ATM switching networks.

This white paper briefly reviews ATM switch operation and describes how CAM embedded APEX™ devices can be used to optimize this operation.

## ATM Switch

The ATM switch is a high-speed device that uses packet switching techniques in public networks and is capable of supporting many classes of traffic, such as data, video, and voice. ATM traffic consists of a series of fixed-length packets called “cells.” Each cell has a 5-byte fixed length header and a 48-byte payload.

ATM networks, which are connection-oriented devices, need a virtual circuit (VC) to be set up across the network prior to any data transfer. Two types of circuits include the virtual path (VP), which is identified by a virtual path identifier (VPI), and the channel path, which is identified by the virtual channel identifier (VCI).

Virtual path connection (VPC) is used to route multiple virtual channels through an ATM network, and virtual channel connection (VCC) is a bidirectional facility to transfer ATM traffic between layers.

Because VCI/VPI values are localized, each segment of the connection has a unique VPI/VCI combination. When a cell travels through the network from the user network interface (UNI) through the switch to the network node interface (NNI), the VPI/VCI value is changed to the value the next segment of connection uses through a process called a VPI/VCI translation, shown in Figure 1.

Figure 1. VPI/VCI Translation

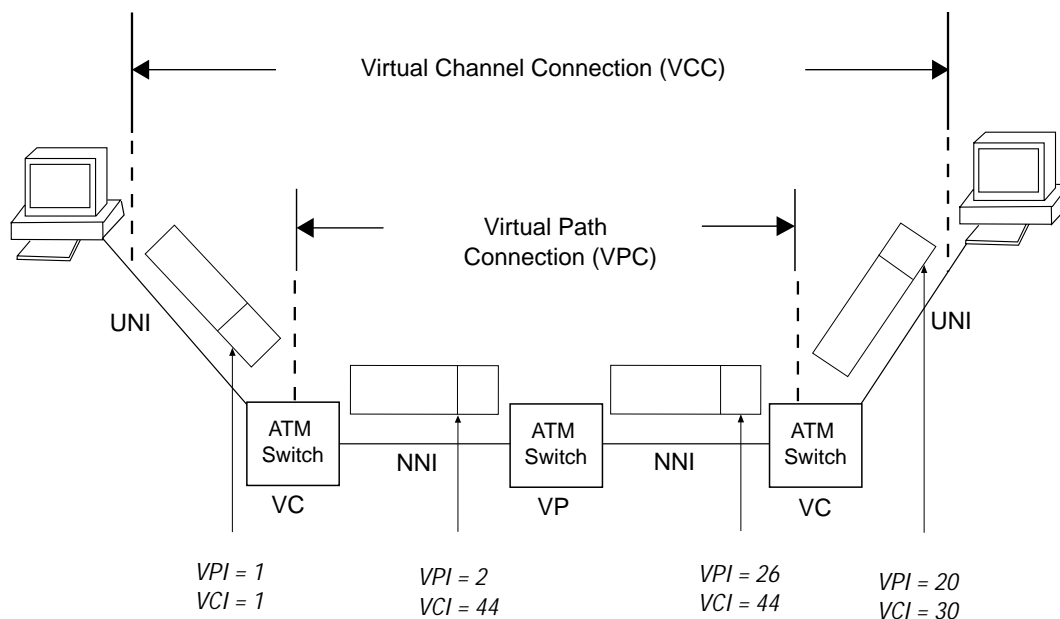
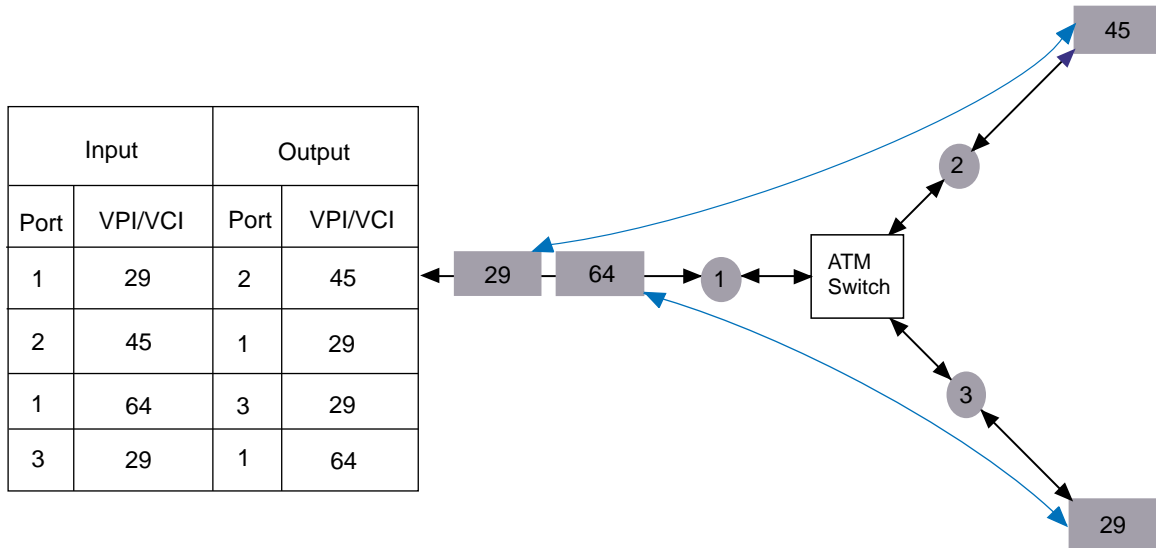

Figure 2 shows the function of an ATM switch where VPI/VCI values are translated. VPI/VCI values are unique per interface; however, the values can be re-used along the network. For example, in Figure 2, the VPI/VCI value of 29 is used in two different interfaces.

Figure 2. VPI/VCI Values Re-Used in Network



### CAM in ATM Switch

The time required to compute VPI/VCI translations is critical in order to determine the performance of ATM networks. CAM can act as an address translator for look-up tables (LUTs) in ATM switches and perform VPI/VCI translation quickly. VPI/VCI fields from the ATM controller are compared against a list of current connections stored in the CAM array. CAM generates an address that is used to access an embedded RAM, where VPI/VCI mapping data and other connection information are stored. VPI/VCI data from RAM is added on to the cell and sent to the switch, as shown in Figure 3.

Figure 3. CAM in ATM Switches

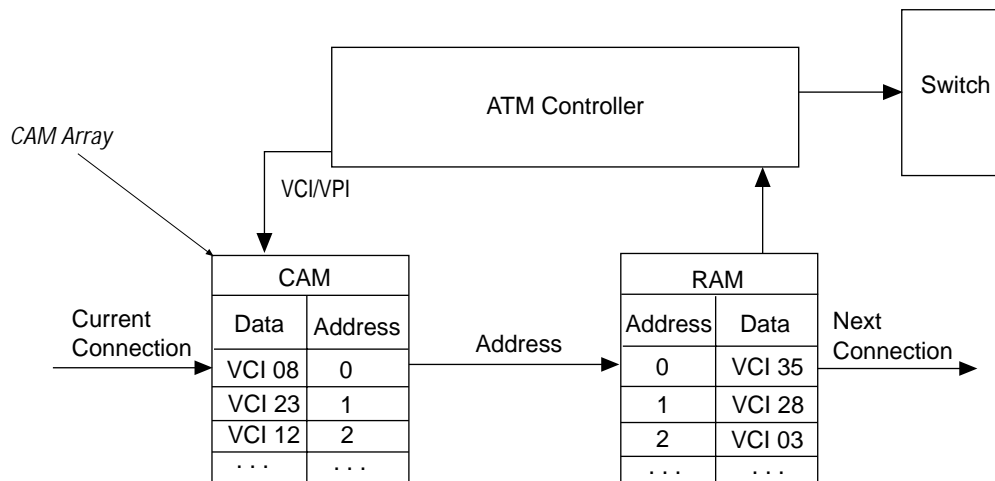

In some ATM applications, there may be a need for larger CAM than can be supported within the APEX device. In such cases, CAM on an APEX device can be used as cache for an external CAM. The external CAM stores all the connections, while the CAM on the device contains more frequently accessed connections. By caching the more recently or frequently accessed connections, system performance is increased.

## Conclusion

The performance of an ATM switch is determined in part by the speed of VCI/VPI translation. By using the APEX embedded CAM, the translation can be optimized, improving system performance.



101 Innovation Drive  
San Jose, CA 95134  
(408) 544-7000  
<http://www.altera.com>

Copyright © 2000 Altera Corporation. Altera and APEX are trademarks and/or service marks of Altera Corporation in the United States and other countries. Other brands or products are trademarks of their respective holders. The specifications contained herein are subject to change without notice. Altera assumes no responsibility or liability arising out of the application or use of any information, product, or service described herein except as expressly agreed to in writing by Altera Corporation. Altera customers are advised to obtain the latest version of device specifications before relying on any published information and before placing orders for products or services. All rights reserved.