



# Avalon Interface Specifications

---



101 Innovation Drive  
San Jose, CA 95134  
[www.altera.com](http://www.altera.com)

Document Version: 1.1  
Document Date: October 2008

Copyright © 2008 Altera Corporation. All rights reserved. Altera, The Programmable Solutions Company, the stylized Altera logo, specific device designations, and all other words and logos that are identified as trademarks and/or service marks are, unless noted otherwise, the trademarks and service marks of Altera Corporation in the U.S. and other countries. All other product or service names are the property of their respective holders. Altera products are protected under numerous U.S. and foreign patents and pending applications, maskwork rights, and copyrights. Altera warrants performance of its semiconductor products to current specifications in accordance with Altera's standard warranty, but reserves the right to make changes to any products and services at any time without notice. Altera assumes no responsibility or liability arising out of the application or use of any information, product, or service described herein except as expressly agreed to in writing by Altera Corporation. Altera customers are advised to obtain the latest version of device specifications before relying on any published information and before placing orders for products or services.

MNL-AVABUSREF-1.1





# Table of Contents

1.1. Avalon Properties and Parameters .....	1-4
1.2. Signal Types .....	1-4
1.3. Interface Timing .....	1-5
1.4. Related Documents .....	1-5
2.1. Clock Input (Sink) .....	2-1
2.1.1. Properties .....	2-2
2.1.2. Signal Types .....	2-2
2.1.3. associatedClock Interfaces .....	2-2
2.2. Clock Output (Source) .....	2-2
2.2.1. Properties .....	2-3
2.2.2. Signal Types .....	2-3
3.1. Introduction .....	3-1
3.2. Slaves .....	3-3
3.3. Slave Interface Properties .....	3-5
3.4. Slave Timing .....	3-8
3.4.1. Synchronous Interface .....	3-8
3.4.2. Performance .....	3-8
3.4.3. Electrical Characteristics .....	3-8
3.5. Slave Transfers .....	3-8
3.5.1. Typical Slave Read and Write Transfers .....	3-8
3.5.2. Slave Read and Write Transfers with Fixed Wait-States .....	3-9
3.5.3. Pipelined Transfers .....	3-10
3.5.3.1. Slave Pipelined Read Transfer with Variable Latency .....	3-11
3.5.3.2. Restrictions .....	3-12
3.5.3.3. Slave Pipelined Read Transfer with Fixed Latency .....	3-12
3.5.4. Burst Transfers .....	3-13
3.5.4.1. Slave Write Bursts .....	3-14
3.5.4.2. Slave Read Bursts .....	3-15
3.5.4.3. Line-Wrapped Bursts .....	3-16
3.5.4.4. Flow Control .....	3-17
3.6. Address Alignment .....	3-17
3.7. Masters .....	3-19
3.8. Master Signal Types .....	3-20
3.9. Master Interface Properties .....	3-23
3.10. Master Transfers .....	3-24
3.10.1. Master Pipelined Read Transfer .....	3-25
3.10.2. Burst Transfers .....	3-27
3.10.2.1. Master Write Bursts .....	3-27
3.10.2.2. Master Read Bursts .....	3-28
4.1. Interrupt Sender .....	4-1
4.1.1. Signal Types .....	4-1

## Table of Contents

---

4.1.2. Interrupt Sender Properties .....	4-2
4.2. Interrupt Receiver .....	4-2
4.2.1. Interrupt Receiver Properties .....	4-3
4.2.2. Signal Types .....	4-3
4.2.3. Interrupt Timing .....	4-3
5.1. Tristate Slave Signal Types .....	5-2
5.1.1. address Behavior .....	5-3
5.1.2. outputenable and read Behavior .....	5-4
5.1.3. write_n and writebyteenable Behavior .....	5-4
5.1.4. Interfacing to Synchronous Off-Chip Memory .....	5-5
5.2. Tristate Slave Properties .....	5-6
5.3. Slave Transfers .....	5-6
5.3.1. Asynchronous Transfers .....	5-6
5.3.1.1. Setup Time .....	5-7
5.3.1.2. Hold Time .....	5-8
5.3.1.3. Example Read and Write Using Setup, Hold and Wait Times .....	5-8
5.3.2. Synchronous Transfers .....	5-10
5.3.3. Pipelined Slave Read Transfers .....	5-10
5.4. Master Transfers .....	5-12
6.1. Introduction .....	6-1
6.1.1. Features .....	6-2
6.1.2. Terms and Concepts .....	6-2
6.2. Avalon-ST Interface Signals .....	6-3
6.2.1. Signal Polarity .....	6-4
6.2.2. Signal Sequencing and Timing .....	6-5
6.2.2.1. Synchronous Interface .....	6-5
6.2.2.2. Clock Enables .....	6-5
6.3. Avalon-ST Interface Properties .....	6-5
6.4. Typical Data Transfers .....	6-6
6.4.1. Signal Details .....	6-6
6.4.2. Data Layout .....	6-7
6.5. Data Transfer without Backpressure .....	6-8
6.6. Data Transfer with Backpressure .....	6-9
6.7. Packet Data Transfers .....	6-10
6.7.1. Signal Details .....	6-11
6.7.2. Protocol Details .....	6-11
7.1. Properties .....	7-2
7.2. Signals .....	7-2
Document Revision History .....	Info-1
How to Contact Altera .....	Info-1
Typographic Conventions .....	Info-2

Avalon® interfaces simplify system design by allowing you to easily connect components in an FPGA. The Avalon interface family defines interfaces for use in both high-speed streaming and memory-mapped applications. These standard interfaces are designed into the components available in the system-on-a-programmable-chip (SOPC) environment and the MegaWizard Plug-In Manager. You can also use these standardized interfaces in your custom components.

This specification defines all of the Avalon interfaces. After reading it, you should understand which interfaces are appropriate for your components and which signal types are used for which desired behaviors. There are six different interface types:

- Avalon Memory Mapped Interface (Avalon-MM)—an address-based read/write interface typical of master-slave connections
- Avalon Streaming Interface (Avalon-ST)—an interface that supports the unidirectional flow of data, including multiplexed streams, packets, and DSP data
- Avalon Memory Mapped Tristate Interface—an address-based read/write interface to support off-chip peripherals. Multiple peripherals can share data and address buses to reduce the pincount of an FPGA and the number of traces on the PCB
- Avalon Clock—an interface that drives or receives clock and reset signals to synchronize interfaces and provide reset connectivity
- Avalon Interrupt—an interface that allows components to signal events to other components
- Avalon Conduit—an interface that allows signals to be exported out at the top level of an SOPC Builder system where they can be connected to other modules of the design or FPGA pins

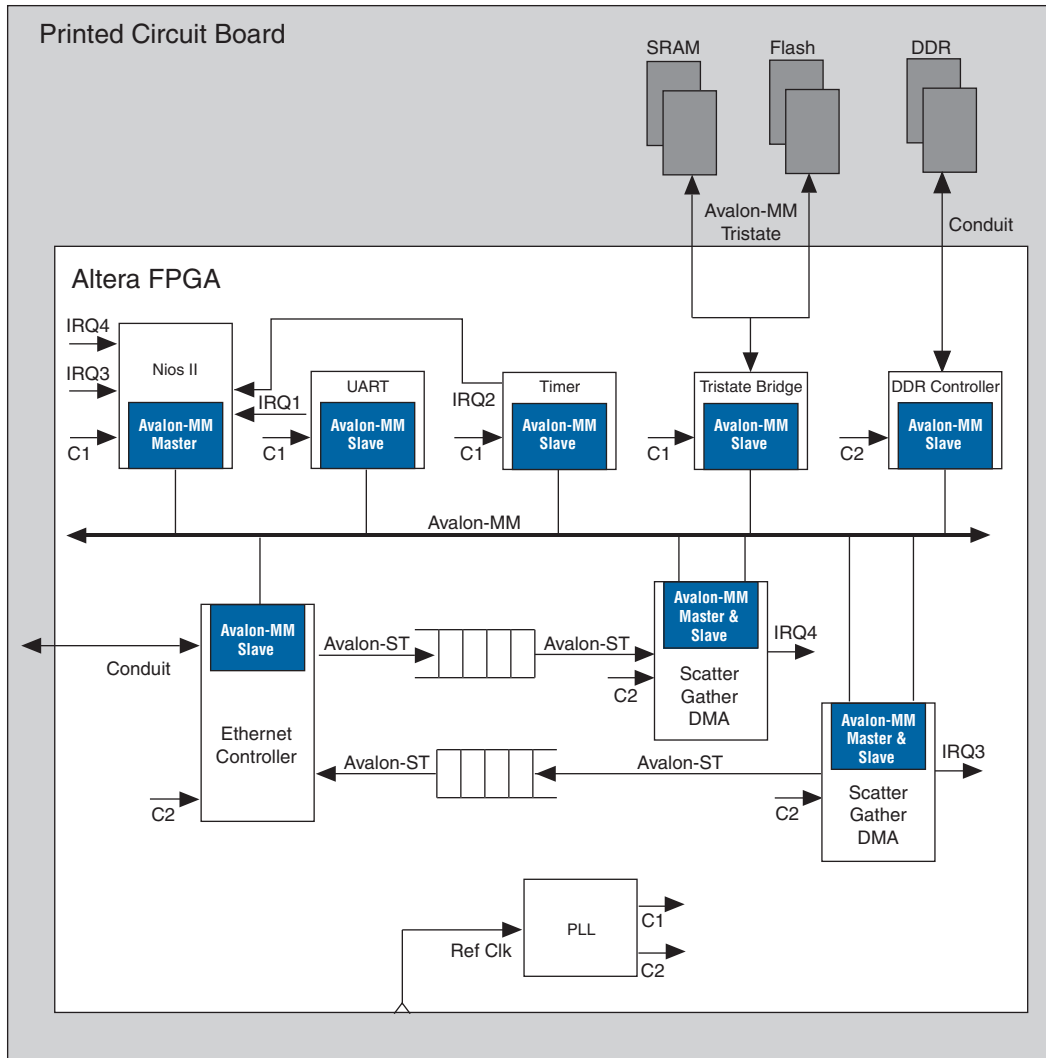
A single component can include any number of these interfaces and can also include multiple instances of the same interface type. For example, in [Figure 1.1](#), the Ethernet Controller includes four different interface types: Avalon-MM, Avalon-ST, clock, and conduit.



This specification supersedes the separate specifications for the Avalon-MM Interface and the Avalon-ST Interfaces.

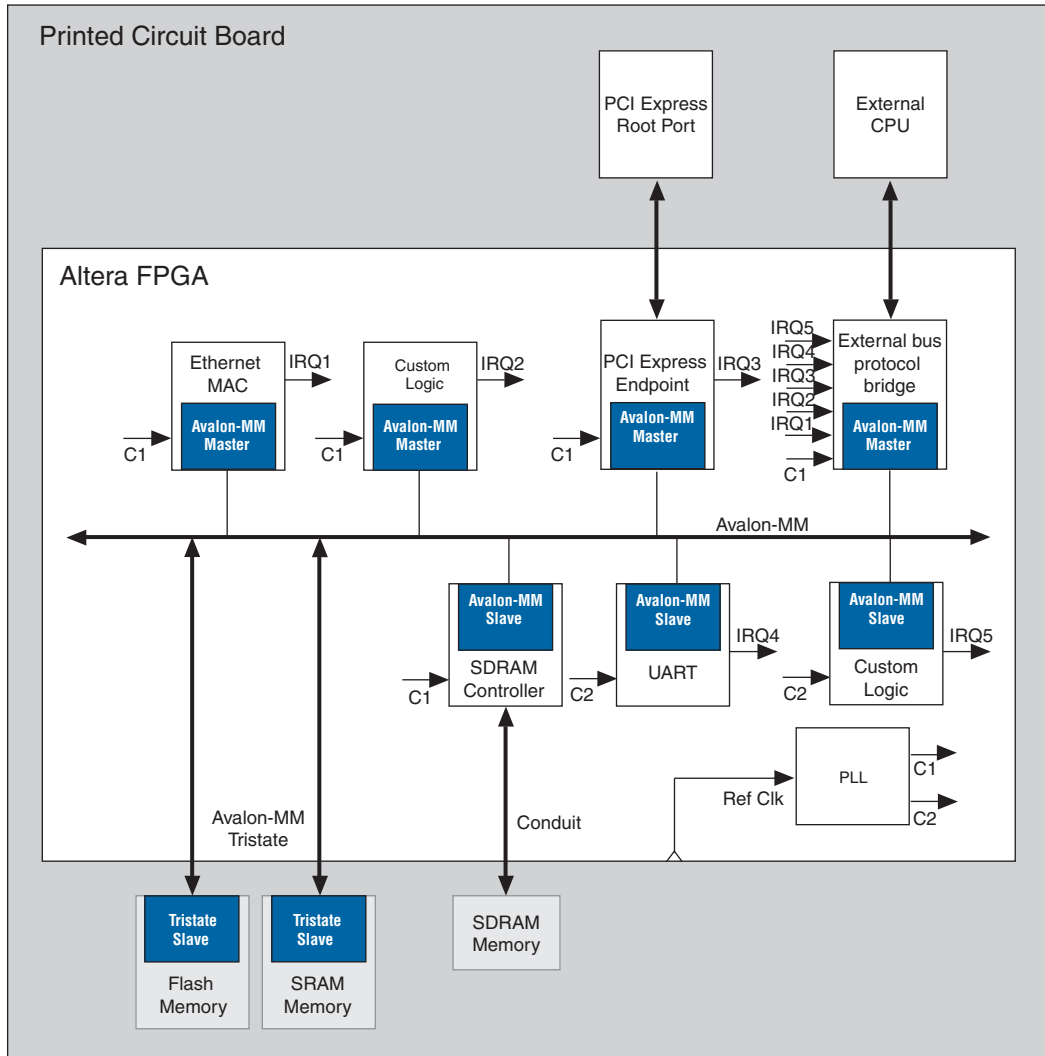
Figures 1.1 and 1.2 illustrate the use of each of the Avalon interfaces.

**Figure 1.1. Avalon Interfaces in a System Design with Scatter Gather DMA Controller and Nios II Processor**



In Figure 1.1, the Nios® II processor accesses the control and status registers of on-chip components using an Avalon-MM interface. The scatter gather DMAs send and receive data using Avalon-ST interfaces. Four components include interrupt interfaces that are serviced by software running on the Nios II processor. A PLL accepts a clock via a clock sink interface and provides two clock sources. Finally, two components include conduit interfaces to access off-chip resources.

**Figure 1.2. Avalon Interfaces in a System Design with PCI Express Endpoint and External Processor**



In [Figure 1.2](#), an external processor accesses the control and status registers of on-chip components via an external bus bridge with an Avalon-MM interface. The PCI Express root port controls the printed circuit board and the other components of the FPGA by driving an on-chip PCI Express endpoint with an Avalon-MM master interface. Five components include interrupts that are handled by the external processor. As in [Figure 1.1](#), a PLL accepts a reference clock via a clock sink interface and provides two clock sources. Finally, the flash and SRAM memories use an Avalon-MM tristate interface to share FPGA pins.

### 1.1. Avalon Properties and Parameters

Avalon interfaces use properties to describe their behavior. For example, the `setupTime` and `holdTime` properties of an Avalon-MM tristate interface specify the timing of external memory devices. The `maxChannel` property of Avalon-ST interfaces allows you to state the number of channels supported by the interface. The specification for each interface type defines all of its properties and specifies the default values. For a complete list of properties for each interface type, refer to the following sections:

- For Avalon-MM properties, refer to: [“Slave Interface Properties” on page 3–5](#) and [“Master Interface Properties” on page 3–23](#)
- For Avalon-MM tristate properties, refer to: [“Tristate Slave Properties” on page 5–6](#)
- For Avalon-ST properties, refer to: [“Avalon-ST Interface Properties” on page 6–5](#)
- For the properties of interrupts, refer to: [“Interrupt Sender Properties” on page 4–2](#) and [“Interrupt Receiver Properties” on page 4–3](#)

### 1.2. Signal Types

Each of the Avalon interfaces defines a number of signal types and their behavior. Many signal types are optional, allowing component designers the flexibility to select only the signal types necessary. For example, the Avalon-MM interface includes optional `beginbursttransfer` and `burstcount` signal types used only for components that support bursting. The Avalon-ST interface includes the optional `startofpacket` and `endofpacket` signal types for interfaces that support packets.

With the exception of conduit interfaces, each interface may only include one signal of each signal type. Active-low signals are permitted for many signal types. Active-high signals are generally used in this document.



## 1.3. Interface Timing

Subsequent chapters of this document include timing information that describes transfers for individual interface types interfaces. There is no guaranteed performance for any of these interfaces; actual performance depends on many factors, including component design and system implementation.

Most Avalon interfaces must not be edge sensitive to signals other than the clock, because the signals may transition multiple times before they stabilize. The exact timing of signals between clock edges varies depending upon the characteristics of the selected Altera device.

## 1.4. Related Documents

You can find additional information on related topics in the following documents:

- *Quartus II Handbook Volume 4: SOPC Builder*

This volume includes information on memory-mapped and streaming interfaces, Tcl scripting, designing memory sub-systems, and interconnect components.

- *Quartus II Handbook Volume 5: Embedded Peripherals*

This volume includes documentation for the many embedded peripherals that are available in SOPC Builder.

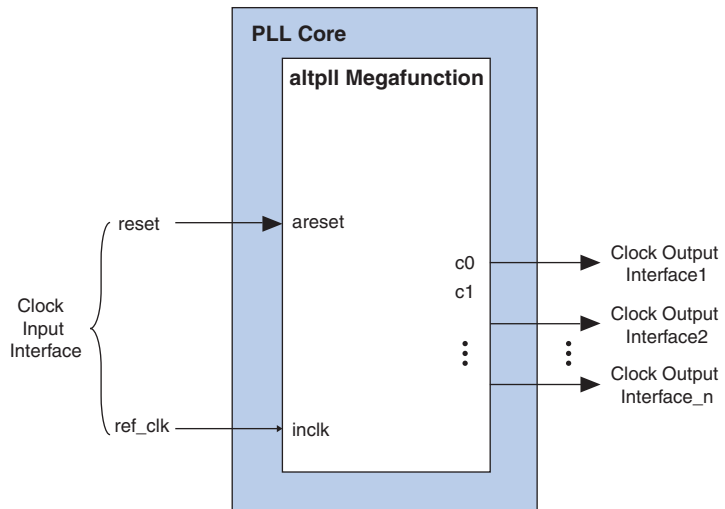
- *Building a Component Interface with Tcl Scripting Commands.*

This is a reference for a programmatic interface that you can use to define SOPC Builder components.



Clock interfaces are used to define the clock and resets used by a component. Typical components have one or more clock inputs; they rarely have clock outputs. A phase locked loop (PLL) is an example of a component that has both a clock input and clock outputs. [Figure 2.1](#) is a simplified illustration showing the most important inputs and outputs of a PLL component.

**Figure 2.1. PLL Core Clock Outputs and Inputs**



### 2.1. Clock Input (Sink)

A clock input interface is used to provide synchronization and reset control for a component. A typical component has a clock input to provide a timing reference for other interfaces and internal logic.

All reset inputs are connected to the logical OR of all system reset requests. Reset inputs are always asserted asynchronously. If the clock input interface has a clock input and a reset input, the reset is deasserted synchronously to the clock input.

### 2.1.1. Properties

There are no properties for the clock sink interface.

### 2.1.2. Signal Types

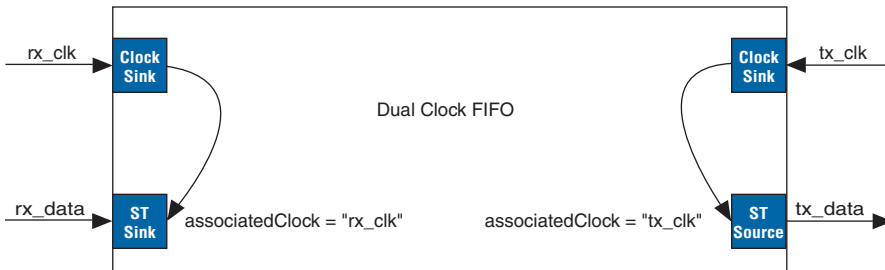
Table 2.1 lists the clock input signals.

Signal Type	Width	Direction	Required	Description
clk	1	Input	No	A clock signal. Provides synchronization for internal logic and for other interfaces.
reset reset_n	1	Input	No	Reset input. Resets the internal logic of an interface or component to a determined state.  reset is synchronized to the clock input in the same interface.

### 2.1.3. associatedClock Interfaces

All synchronous interfaces have an associatedClock property that specifies which clock input on the component is used as a synchronization reference for the interface. This property is illustrated in Figure 2.2.

Figure 2.2. associatedClock Property



## 2.2. Clock Output (Source)

A clock source interface, or clock output interface, is an interface that drives a clock signal out of a component. Clock output interfaces cannot have reset signals.

### 2.2.1. Properties

There are no properties for clock source interfaces.

### 2.2.2. Signal Types

Table 2.2 lists the clock source signals.

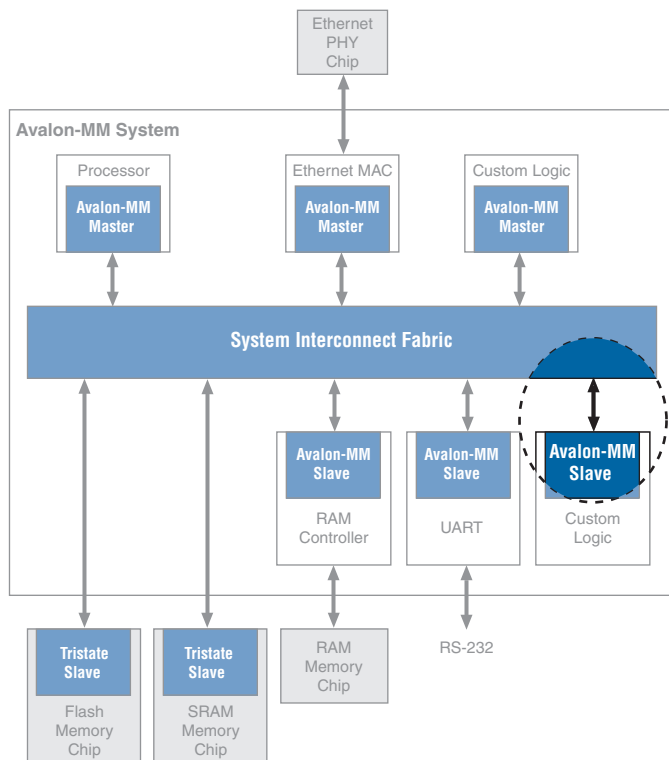
<i>Table 2.2. Clock Source Signal Types</i>				
Signal Type	Width	Direction	Required	Description
clk	1	Output	Yes	An output clock signal.



#### 3.1. Introduction

Avalon Memory-Mapped (Avalon-MM) interfaces are used for read/write interfaces on master and slave components in a memory-mapped system. These components include microprocessors, memories, UARTs, and timers, and have master and slave interfaces connected by a system interconnect fabric. Avalon-MM interfaces can describe a wide variety of components, from an SRAM which supports simple, fixed-cycle read/write transfers to a more complex, pipelined interface capable of burst transfers. Figure 3.1 shows a typical system, highlighting the Avalon-MM slave interface connection to the system interconnect fabric.

**Figure 3.1. Focus on Avalon-MM Slave Transfers**



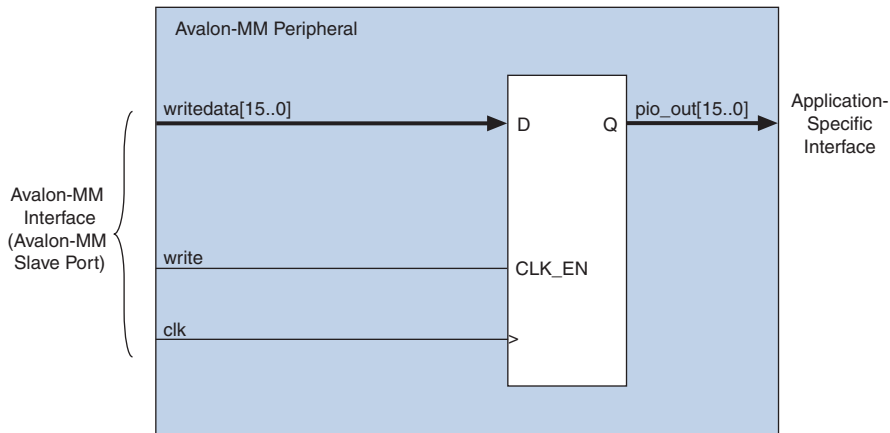
Features of the Avalon-MM interface include:

- Definition of a point to point connection between a component and an interconnect fabric
- Freedom to implement only the required subset of signals
- Variable data widths: 8, 16, 32, 64, . . . 1024
- Automatic interconnect generation

Avalon-MM components typically include only the signals required for the component logic. The 16-bit general-purpose I/O peripheral shown in [Figure 3.2](#) only responds to write requests, therefore it only includes the slave signals required for write transfers.

---

**Figure 3.2. Example Slave Component**



---

Each signal in an Avalon-MM slave corresponds to exactly one Avalon-MM signal type. An Avalon-MM port can use only one instance of each signal type.



## 3.2. Slaves

Table 3.1 lists the signal types that constitute the Avalon-MM slave. This specification does not require all signals to exist in an Avalon-MM slave. The minimum requirements are `readdata` for a read-only interface or `writedata` and `write` for a write-only interface.

<i>Table 3.1. Avalon-MM Slave Port Signals (1) (Part 1 of 3)</i>				
Signal Type	Width	Dir	Req'd	Description
<b>Fundamental Signals</b>				
<code>read</code> <code>read_n</code>	1	In	No	Asserted to indicate a <code>read</code> transfer. If present, <code>readdata</code> is required.
<code>write</code> <code>write_n</code>	1	In	No	Asserted to indicate a <code>write</code> transfer. If present, <code>writedata</code> is required.
<code>address</code>	1-32	In	No	Specifies an offset into the slave address space. Each slave address value selects a word of slave data. For example, <code>address=0</code> selects the first <slave data width> bits of slave data; <code>address=1</code> selects the second <slave data width> bits of slave data.
<code>readdata</code>	8,16,32, 64, 128,256, 512 1024	Out	No	The <code>readdata</code> provided by the slave in response to a <code>read</code> transfer.
<code>writedata</code>	8,16,32, 64, 128,256, 512,102 4	In	No	Data from the system interconnect fabric for write transfers. The width must be the same as the width of <code>readdata</code> if both are present.

**Table 3.1. Avalon-MM Slave Port Signals (1) (Part 2 of 3)**

Signal Type	Width	Dir	Req'd	Description														
byteenable byteenable_n	1,2,4,8, 16, 32, 64, 128	In	No	Enables specific byte lane(s) during transfers. Each bit in <code>byteenable</code> corresponds to a byte in <code>writedata</code> and <code>readdata</code> . During writes, <code>byteenables</code> specify which bytes are being written to; other bytes should be ignored by the slave. During reads, <code>byteenables</code> indicates which bytes the master is reading. Slaves that simply return <code>readdata</code> with no side effects are free to ignore <code>byteenables</code> during reads. When more than one bit is asserted, all asserted lanes are adjacent. The number of adjacent lines must be a power of two, and the specified bytes must be aligned on an address boundary for the size of the data. The following values are legal for a 32-bit slave: <table style="margin-left: 20px; border: none;"> <tr><td>1111</td><td>write full 32 bits</td></tr> <tr><td>0011</td><td>writes lower 2 bytes</td></tr> <tr><td>1100</td><td>writes upper 2 bytes</td></tr> <tr><td>0001</td><td>writes byte 0 only</td></tr> <tr><td>0010</td><td>write byte 1 only</td></tr> <tr><td>0100</td><td>write byte 2 only</td></tr> <tr><td>1000</td><td>write byte 3 only</td></tr> </table>	1111	write full 32 bits	0011	writes lower 2 bytes	1100	writes upper 2 bytes	0001	writes byte 0 only	0010	write byte 1 only	0100	write byte 2 only	1000	write byte 3 only
1111	write full 32 bits																	
0011	writes lower 2 bytes																	
1100	writes upper 2 bytes																	
0001	writes byte 0 only																	
0010	write byte 1 only																	
0100	write byte 2 only																	
1000	write byte 3 only																	
<code>begintransfer</code>	1	In	No	Asserted by the system interconnect fabric for the first cycle of each transfer regardless of <code>waitrequest</code> and other signals.														
<b>Wait-State Signals</b>																		
<code>waitrequest</code> <code>waitrequest_n</code>	1	Out	No	Asserted by the slave when it is unable to respond to a read or write request. When asserted, the control signals to the slave, with the exception of <code>begintransfer</code> and <code>beginbursttransfer</code> , remain constant, as is illustrated by <a href="#">Figure 3.7 on page 3–15</a> . An Avalon-MM slave may assert <code>waitrequest</code> during idle cycles. An Avalon-MM master may initiate a transaction when <code>waitrequest</code> is asserted. The design of Avalon-MM slaves must take this possibility into account.														
<b>Pipeline Signals</b>																		
<code>readdatavalid</code> <code>readdatavalid_n</code>	1	Out	No	Used for variable-latency, pipelined read transfers. Asserted by the slave to indicate that the <code>readdata</code> signal contains valid data in response to a previous read request. A slave with <code>readdatavalid</code> must assert this signal for one cycle for each read access it has received. There must be at least one cycle of latency between acceptance of the read and assertion of <code>readdatavalid</code> . <a href="#">Figure 3.5 on page 3–12</a> illustrates the <code>readdatavalid</code> signal.														

<b>Table 3.1. Avalon-MM Slave Port Signals (1) (Part 3 of 3)</b>				
<b>Signal Type</b>	<b>Width</b>	<b>Dir</b>	<b>Req'd</b>	<b>Description</b>
<b>Burst Signals</b>				
burstcount	1-32	In	No	During the first cycle of a burst, burstcount indicates the number of transfers the burst contains. A burstcount port of width $N$ can encode a max burst of size $2^{(N-1)}$ . The burstcount signal remains constant for entire transfer.
beginbursttransfer	1	In	No	Asserted for the first cycle of a burst to indicate when a burst transfer is starting. This signal is deasserted after one cycle regardless of the value of waitrequest. Refer to <a href="#">Figure 3.3</a> for an example of its use.
<b>Flow Control Signals</b>				
readyfordata	1	Out	No	Used for transfers with flow control. Indicates that the peripheral is ready for a write transfer.
dataavailable	1	Out	No	Used for transfers with flow control. Indicates that the peripheral is ready for a read transfer.
<b>Reset Signals</b>				
resetrequest resetrequest_n	1	Out	No	Allows the peripheral to reset the entire Avalon-MM system. All reset signals are ORed together to generate the system reset signal.

**Notes to Table 3.1:**

- (1) All Avalon signals are active high. Avalon signals that can also be asserted low list a *\_n* versions of the signal in the **Signal Type** column.

### 3.3.Slave Interface Properties

Table 3–2 describes the interface properties for an Avalon-MM slave interface.

Name	Default Value	Legal Values	Description
readLatency	0	0–63	Read latency for fixed-latency slaves. Not used on interfaces that include the <code>readdatavalid</code> signal. Refer to <a href="#">Figure 5.5 on page 5–12</a> for a timing diagram that uses this property.
writeWaitTime	0	0–1000 cycles	For slave interfaces that don't use the <code>waitrequest</code> signal, <code>writeWaitTime</code> indicates the number of cycles before the slave accepts a write. The timing is as if the slave asserted <code>waitrequest</code> for <code>writeWaitTime</code> cycles. Refer to <a href="#">Figure 3.4 on page 3–10</a> for a timing diagram that uses this property.
readWaitTime	1	0–1000 cycles	For slave interfaces that don't use the <code>waitrequest</code> signal, <code>readWaitTime</code> indicates the number of cycles before the slave responds to a read. The timing is as if the slave asserted <code>waitrequest</code> for <code>readWaitTime</code> cycles.
maximumPendingRead Transactions	1 (1)	1–64	The maximum number of pending reads which can be queued up by the slave. Refer to <a href="#">Figure 3.5 on page 3–12</a> for a timing diagram that uses this property.
burstOnBurstBoundariesOnly	false	true,false	If true, burst transfers presented to this interface are guaranteed to begin at addresses which are multiples of the burst size.
linewrapBursts	false	true,false	If true, indicates that the slave implements a line wrapping burst instead of an incrementing burst. With a wrapping burst, when the address reaches a burst boundary, it wraps back to the previous burst boundary such that only the low order bits need to be used for addressing. A wrapping burst with burst boundaries every 32 bytes across a 32-bit interface to address 0xC would write to addresses 0xC, 0x10, 0x14, 0x18, 0x1C, 0x0, 0x4, and 0x8.

**Table 3–2. Avalon-MM Slave Interface Properties (Part 2 of 2)**

Name	Default Value	Legal Values	Description
maxBurstSize	1	64	The maximum burst size that a slave can accept.
bridgesToMaster	null	Avalon-MM master on same component	An Avalon-MM bridge consists of a slave and a master, and has the property that an access to the slave requesting a particular byte or bytes will cause the same byte or bytes to be requested by the master.
associatedClock	—	—	Name of the clock interface that this Avalon-MM slave interface is synchronous to.

*Note to Table 3–2:*

- (1) If a component accepts more read transfers than the value indicated here, the internal pending read FIFO may overflow, causing the system to lockup.

## 3.4. Slave Timing

This section describes issues related to timing and sequencing of Avalon-MM slave signals.

### 3.4.1. Synchronous Interface

The Avalon-MM interface is a synchronous protocol. Each Avalon-MM port is synchronized to an associated clock interface. Signals may be combinational if they are driven from the outputs of registers that are synchronous to the clock signal. An Avalon-MM peripheral must not be sensitive to any signal besides the reference clock. This document does not dictate how or when signals transition between clock edges and timing diagrams are devoid of fine-grained timing information.

### 3.4.2. Performance

There is no guaranteed performance of the Avalon-MM interface. The maximum performance is dependent on peripheral design and system implementation.

### 3.4.3. Electrical Characteristics

The Avalon-MM interface specification does not specify any electrical characteristics.

## 3.5. Slave Transfers

This section defines two basic concepts before introducing the slave transfer types.

- *Transfer*—A transfer is a read or write operation of a word of data, between an Avalon-MM slave and the system interconnect fabric. Avalon-MM transfers words ranging in size from 8–1024 bits. Transfers take one or more clock cycles to complete.

Both masters and slaves are part of a transfer; the Avalon-MM master initiates the transfer and the Avalon-MM slave responds to it.

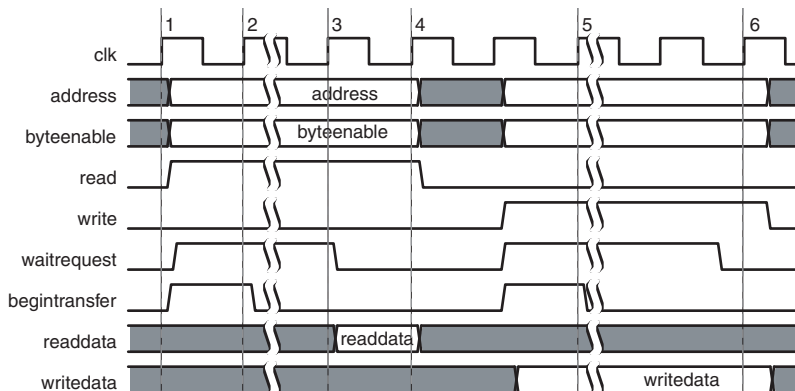
- *Master-slave pair* —This term refers to the master port and slave port involved in a transfer. During a transfer, the master port's control and data signals pass through the system interconnect fabric and interact with the slave port.

### 3.5.1. Typical Slave Read and Write Transfers

This section describes a typical Avalon-MM slave that supports read and write transfers with peripheral-controlled `waitrequest`. The slave can stall the system interconnect fabric for as many cycles as required by asserting the `waitrequest` signal. If a slave uses peripheral-controlled `waitrequest` for either read or write transfers, it must use peripheral-controlled `waitrequest` for both.

The slave receives `address`, `byteenable`, `read` or `write`, and `writedata` after the rising edge of the clock. The slave port must assert `waitrequest` before the next rising clock edge to hold off the transfers. When `waitrequest` is asserted, the transfer is delayed and the address and control signals are held constant. Transfers complete on the rising edge of the first `clk` after the slave port deasserts `waitrequest`.

There is no limit on how long a slave port can stall. Therefore, you must ensure that a slave port does not assert `waitrequest` indefinitely. [Figure 3.3](#) shows read and write transfers using `waitrequest`.

**Figure 3.3. Slave Read and Write Transfers with Peripheral-Controlled Waitrequest****Notes to Figure 3.3:**

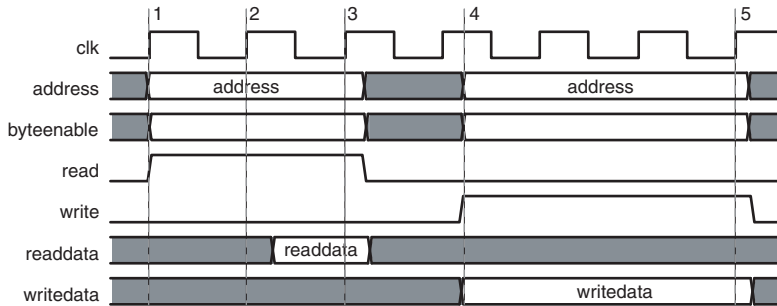
- (1) address, read and begintransfer are asserted after the rising edge of clk. The slave asserts waitrequest, stalling the transfer.
- (2) waitrequest is sampled. Because waitrequest is asserted, the cycle becomes a wait-state, and address, read, write, and byteenable remain constant. Begintransfer is not held constant.
- (3) The slave presents valid readdata and deasserts waitrequest.
- (4) readdata and deasserted waitrequest are sampled, completing the transfer.
- (5) address, writedata, byteenable, begintransfer and write signals are asserted. The slave responds by asserting waitrequest, stalling the transfer.
- (6) The slave captures writedata and deasserts waitrequest, ending the transfer.

### 3.5.2. Slave Read and Write Transfers with Fixed Wait-States

Instead of using waitrequest to hold off a transfer, a slave can specify fixed wait-states using the readWaitTime and writeWaitTime properties. The address and control signals (byteenable, read, and write) are held constant for the duration of the transfer. The read/write timing with readWaitTime/writeWaitTime set to  $N$  is exactly the same as asserting waitrequest for  $N$  cycles per transfer.

Figure 3.4 shows an example slave read and write transfers with `writeWaitTime = 2` and `readWaitTime = 1`.

**Figure 3.4. Slave Read and Write Transfer with Fixed Wait-States**



**Notes to Figure 3.4:**

- (1) address and read are asserted on the rising edge of clk.
- (2) The next rising edge of clk marks the end of the first and only wait-state cycle because the `readWaitTime` is 1.
- (3) readdata is captured on the rising edge of clk, and the read transfer ends.
- (4) writedata, address, byteenable, and write signals are available to the slave.
- (5) Because `writeWaitTime` is 2, the transfer terminates after completing. The data and control signals are held constant until this time.

Transfers with a single wait-state are commonly used for synchronous, on-chip peripherals. The peripheral can capture address and control signals on the rising edge of `clk`, and has one full cycle to return data. Components with zero wait-states are allowed, but may decrease achievable frequency because they generate the response in the same cycle as the request.

### 3.5.3. Pipelined Transfers

Avalon-MM pipelined read transfers increase the throughput for synchronous slave peripherals that require several cycles to return data for the first access, but can return one data value per cycle for some time thereafter. New pipelined read transfers can be started before readdata for the previous transfers is returned. Write transfers cannot be pipelined.

A pipelined read transfer is divided into two phases: an address phase and a data phase. A master initiates a transfer by presenting the address during the address phase; a slave port fulfills the transfer by delivering the data during the data phase. The address phase for a new transfer (or multiple transfers) can begin before the data phase of a previous transfer completes. This delay is called *pipeline latency*, which is the duration from the end of the address phase to the beginning of the data phase.



The key differences between how wait-states and pipeline latency affect transfer timing is as follows:

- *Wait-states*—Wait-states determine the length of the address phase, and limit the maximum throughput of a port. If a slave requires one wait-state to respond to a transfer request, then the port requires at least two clock cycles per transfer.
- *Pipeline Latency*—Pipeline latency determines the time until data is returned independently of the address phase. A pipelined slave port with no wait-states can sustain one transfer per cycle, even though it may require several cycles of latency to return the first unit of data.

Wait states and pipelined reads can be supported concurrently, and pipeline latency can be either fixed or variable, as discussed in the following sections.

### 3.5.3.1. Slave Pipelined Read Transfer with Variable Latency

An Avalon-MM pipelined slave takes one or more cycles to produce data after address and control signals have been captured. A pipelined slave port may have multiple pending read transfers at any given time. Variable-latency pipelined read transfers use the same set of signals as non-pipelined read transfers, with one additional signal, `readdatavalid`. Slave peripherals that use `readdatavalid` are considered pipelined with variable latency; the `readdata` and `readdatavalid` signals can be asserted the cycle after the read cycle is asserted, at the earliest.

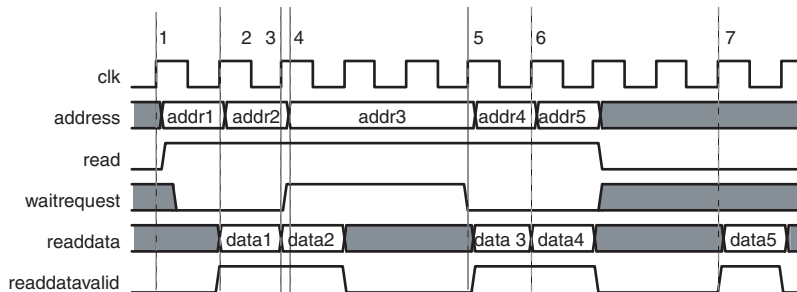
The slave port must return `readdata` in the same order that it accepted the addresses. Pipelined slave ports with variable latency must use peripheral-controlled `waitrequest`. The slave can assert `waitrequest` to stall transfers to maintain the number of pending transfers at an acceptable level.



The maximum number of pending transfers is a property of the slave interface. The system interconnect fabric builds logic which routes `readdata` to the requesting masters, parameterized by this maximum number. It is the responsibility of the slave interface, not the system interconnect fabric, to keep the number of pending reads from exceeding the stated maximum. Typically, the slave interface restricts the number of pending reads by asserting `waitrequest` when that number has reached the maximum value

Figure 3.5 shows several slave read transfers between the system interconnect fabric and a pipelined slave with variable latency. In this example, the slave can accept a maximum of two pending transfers and uses `waitrequest` to prevent overrunning this maximum.

**Figure 3.5. Slave Pipelined Read Transfers with Variable Latency**



**Notes to Figure 3.5:**

- (1) address and read are asserted, initiating a read transfer.
- (2) The slave captures `addr1`, and immediately provides the response `data1` and asserts `readdatavalid`.
- (3) The slave captures `addr2` and immediately provides the response `data2` and asserts `readdatavalid`.
- (4) The slave asserts `waitrequest` causing the third transfer to be stalled for 2 cycles.
- (5) The peripheral drives `readdatavalid` and valid `readdata` in response to the third read transfer.
- (6) The data from transfer 3 is captured by the interconnect as `addr4` is captured by the slave.
- (7) `data5` is presented with `readdatavalid` completing the data phase for the final pending read transfer.

If the slave cannot handle a write transfer while it is processing pending read transfers, the slave must assert its `waitrequest` and stall the write operation until the pending read transfers have completed. The Avalon-MM specification does not define the value of `readdata` in the event that a slave accepts a write transfer to the same address as a currently pending read transfer.

### 3.5.3.2. Restrictions

Pipelined slaves with variable latency must support peripheral-controlled `waitrequest`.

### 3.5.3.3. Slave Pipelined Read Transfer with Fixed Latency

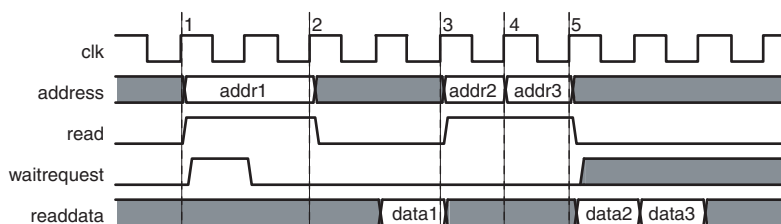
The address phase for fixed latency slave read transfers is identical to the variable latency case. After the address phase, a pipelined slave port with fixed read latency takes a fixed number of clock cycles to return valid `readdata`, as indicated by the `readWaitTime` property. The system interconnect fabric captures `readdata` on the appropriate rising clock edge, and the data phase ends.

During the address phase, the slave port can assert `waitrequest` to hold off the transfer or can specify `readWaitTime` for a fixed number of wait states. The address phase ends on the next rising edge of `clk` after wait-states, if any.

During the data phase, the slave drives `readdata` after a fixed latency. If the peripheral has a read latency of  $N$ , the slave port must present valid `readdata` on the  $N$ th rising edge of `clk` after the end of the address phase.

Figure 3.6 shows multiple data transfers to a slave pipelined port that uses peripheral-controlled `waitrequest` and has a fixed read latency of 2 cycles.

**Figure 3.6. Slave Pipelined Read Transfer with Fixed Latency of Two Cycles**



**Notes to Figure 3.6:**

- (1) A read transfer is initiated with the assertion of `read` and `addr1` and slave asserts `waitrequest` to hold off the transfer for one cycle.
- (2) The slave deasserts `waitrequest` and captures `addr1` at the rising edge of `clk`. The address phase ends here.
- (3) The slave presents valid `readdata` after 2 cycles, ending the transfer.
- (4) `addr2` and `read` are asserted for a new read transfer.
- (5) A third read transfer is issued during the next cycle, before the data from the prior transfer is returned.

### 3.5.4. Burst Transfers

A burst executes multiple transfers as a unit, rather than treating every word independently. Bursts may increase throughput for slave ports that achieve greater efficiency when handling multiple word at a time, such as DDR. The net effect of bursting is to lock the arbitration for the duration of the burst.

To support bursts, an Avalon-MM slave includes a `burstcount` input signal. The `burstcount` signal behaves as follows:

- At the start of a burst, `burstcount` presents the number of sequential transfers in the burst.
- For width  $N$  of `burstcount`, the maximum burst length is  $2^{N-1}$ . The minimum legal burst length is one.

To support slave read bursts, a slave must also support:

- peripheral-controlled wait-states with the `waitrequest` signal.
- Pipelined transfers with variable latency with the `readdatavalid` signal.

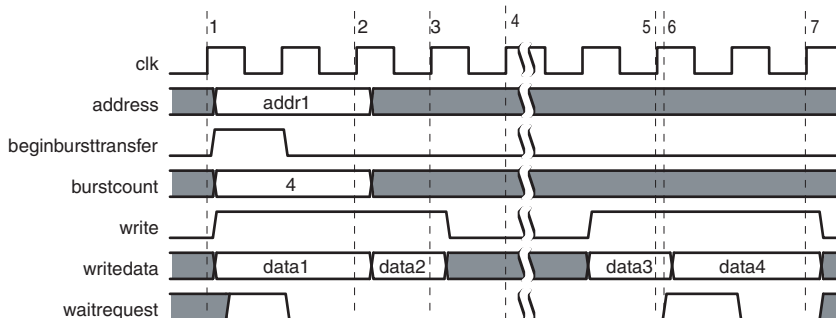
At the start of a burst, the slave sees the address and a burst length value on `burstcount`. For a burst with an address of *A* and a `burstcount` value of *B*, the slave must perform *B* consecutive transfers starting at address *A*. The burst completes after the slave receives (write) or returns (read) the *B*th word of data. The bursting slave must capture address and `burstcount` only once for each burst. The peripheral logic must infer the address for all but the first transfers in the burst. A slave can also use the input signal `beginbursttransfer`, which the system interconnect fabric asserts for the first cycle of each burst.

### 3.5.4.1. Slave Write Bursts

These rules apply when a slave write burst begins with `burstcount` greater than one:

- If a `burstcount` of *N* is presented at the beginning of the burst, then the slave must accept *N* successive units of `writedata` to complete the burst. Arbitration between the master-slave pair is locked until the burst completes, guaranteeing that data arrives, in order, from the master port that initiated the burst.
- The slave must only capture `writedata` when `write` is asserted. During the burst, `write` can be deasserted to indicate that it is not presenting valid `writedata`. Deasserting `write` does not terminate the burst; it only delays it.
- The slave can delay a transfer by asserting `waitrequest` which forces `writedata`, `write`, and `byteenable` to be held constant, as usual.
- The functionality of the `byteenable` signal is the same for bursting and non-bursting slaves. For a 32-bit master burst-writing to a 64-bit slave, starting at byte address 4, the first write transfer seen by the slave is at its address 0, with `byteenable = b'11110000`.
- The `byteenable` signals do not all have to be asserted. A burst master writing unaligned data can use the `byteenable` signal to identify the data being written.

Figure 3.7 demonstrates a slave write burst of length 4. In this example, the slave port asserts `waitrequest` twice delaying the burst.

**Figure 3.7. Slave Write Burst****Notes to Figure 3.7:**

- (1) address, burstcount, write, and the first unit of writedata are asserted. The slave immediately asserts waitrequest, indicating that it is not ready to proceed with the transfer.
- (2) waitrequest is low; the slave captures addr1, burstcount, and the first unit of writedata is accepted. On subsequent cycles of the transfer, address and burstcount are ignored.
- (3) The slave port captures the second unit of data at the rising edge of clk.
- (4) The burst is paused while write is deasserted.
- (5) The slave captures the third unit of data at the rising edge of clk.
- (6) The slave asserts waitrequest. In response, all outputs are held constant through another clock cycle.
- (7) The slave captures the last unit of data on this rising edge of clk. The slave write burst ends.

In Figure 3.7, the beginbursttransfer signal is asserted for the first clock cycle of a burst and is deasserted on the next clock cycle. Even if the slave asserts waitrequest, the beginbursttransfer signal is only asserted for the first clock cycle.

#### 3.5.4.2. Slave Read Bursts

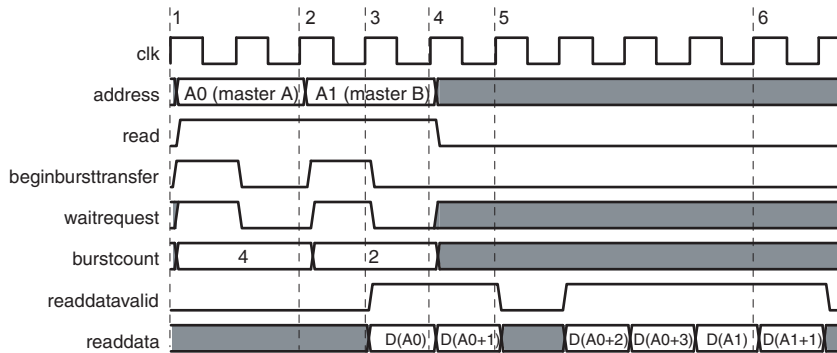
Slave read bursts are similar to slave pipelined read transfers with variable latency. A read burst has distinct address and data phases, and the slave port uses the readdatavalid signal to indicate when it is presenting valid readdata. The difference is that a single read burst address results in multiple data transfers.

These rules apply to slave read bursts:

- When burstcount is  $N$ , the slave must return  $N$  words of readdata to complete the burst.
- The slave presents each word by providing readdata and asserting readdatavalid for a cycle. Deassertion of readdatavalid delays but does not terminate the burst data phase.
- The byteenables presented with a read burst command apply to all cycles of the burst. A byteenable value of 1 means that the least significant byte is being read across all of the read cycles.

Figure 3.8 illustrates a system with two bursting masters accessing a slave. Note that Master B can drive a read request before the data has returned for Master A.

Figure 3.8. Slave Read Burst



Notes to Figure 3.8:

- (1) address (A0), burstcount, and read for master A are asserted after the rising edge of clk. The slave asserts waitrequest, causing all inputs except beginbursttransfer to be held constant through another clock cycle.
- (2) The slave captures A0 and burstcount at this rising edge of clk. A new transfer could start on the next cycle.
- (3) Master B drives address (A1), burstcount, and read. The slave asserts waitrequest, causing all inputs except beginbursttransfer to be held constant. The slave could have returned read data from the first read request at this time, at the earliest.
- (4) The slave presents valid readdata and asserts readdatavalid, transferring the first word of data for master A.
- (5) The second word for master A is transferred. The slave deasserts readdatavalid pausing the read burst. The slave port can keep readdatavalid deasserted for an arbitrary number of clock cycles.
- (6) The first word for master B is returned.

### 3.5.4.3. Line-Wrapped Bursts

Processors with data or instruction caches gain efficiency by using line-wrapped bursts. When a processor requests data, and the data is not in the cache, the cache controller reads enough data from the memory to fill the entire cache line. For a processor with a cache line size of 64 bytes, a cache miss causes 64 bytes to be read from memory. If the processor reads from address 0xC when the cache miss occurred, then an incrementing addressing burst uses read addresses 0x0, 0x4, 0x8, 0xC, 0x10, 0x14, 0x18, and 0x1C – the data that the processor requested isn't available until the fourth read. With wrapping bursts, the address order is 0xC, 0x10, 0x14, 0x18, 0x1C, 0x0, 0x4, and 0x8 such that the data that the processor requested data is returned first.



For more information about burst transfers and burst adapters refer to the *Avalon Memory-Mapped Design Optimizations* chapter in the *Embedded Design Handbook*.

#### 3.5.4.4. Flow Control

A slave, such as a FIFO, can support the `dataavailable` and `readyfordata` signals or both to indicate that it has data available for reading or has space available to which data can be written. Masters that have the `doStreamReads` and `doStreamWrites` properties set see `waitrequest` asserted when they access a slave with the `dataavailable` and `readyfordata` signals deasserted, respectively.

## 3.6. Address Alignment

For systems in which master and slave data widths differ, the interconnect manages address alignment issues. The Avalon-MM interface resolves data width differences, so that any master port can communicate with any slave port, regardless of the respective data widths.

*Dynamic bus sizing* refers to a service provided by the system interconnect fabric that dynamically manages data during transfers between master-slave pairs of differing data widths, such that all slave data are aligned in contiguous bytes in the master address space.

If the master is wider than the slave, data bytes in the master address space map to multiple locations in the slave address space. For example, when a 32-bit master port performs a read transfer from a 16-bit slave port, the system interconnect fabric executes two read transfers on the slave side on consecutive addresses, and presents 32-bits of slave data back to the master port.

If the master is narrower than the slave, then the system interconnect fabric manages the slave byte lanes. During master read transfers, the system interconnect fabric presents only the appropriate byte lanes of slave data to the narrower master. During master write transfers, the system interconnect fabric automatically asserts the `byteenable` signals to write data only to the specified slave byte lanes.

Slaves must have a data width of 8, 16, 32, 64, 128, 256, 512 or 1024 bits. Table 3.3 shows how slave data of various widths is aligned within a 32-bit master. In Table 3.3, OFFSET [N] refers to a slave word size offset into the slave address space.

**Table 3.3. Dynamic Bus Sizing Master-to-Slave Address Mapping**

Master Address	32-Bit Master Data	
	When Accessing a 16-Bit Slave Port	When Accessing a 64-Bit Slave Port
0x00	OFFSET [1] <sub>15..0</sub> :OFFSET [0] <sub>15..0</sub>	OFFSET [0] <sub>31..0</sub>
0x04	OFFSET [3] <sub>15..0</sub> :OFFSET [2] <sub>15..0</sub>	OFFSET [0] <sub>63..32</sub>
0x08	OFFSET [5] <sub>15..0</sub> :OFFSET [4] <sub>15..0</sub>	OFFSET [1] <sub>31..0</sub>
0x0C	OFFSET [7] <sub>15..0</sub> :OFFSET [6] <sub>15..0</sub>	OFFSET [1] <sub>63..32</sub>
...	...	...



Avalon-MM masters always issue byte addresses. If an Avalon-MM master is accessing a 32-bit on-chip slave, the two least significant bits are not connected. The third least significant bit connects to address [0] of the memory device. A 32-bit master port drives addresses aligned on 4-byte boundaries, such as: 0x00, 0x04, 0x08, 0x0c. To write a specific byte within a data word, the master port can use the `byteenable` signal.

In versions of the SOPC Builder software before v8.0, a slave interface could specify that it had *native addressing*. When a master port addresses a slave port with the native address alignment property, all slave data are aligned on *native master* address boundaries. When a master port reads from a narrower slave port, the slave data bits map to the lower bits of the master data, and the upper master data bits are padded with zero. During write transfers, the upper bits are ignored. For example, if a 16-bit master port reads an 8-bit slave port, the `readdata` signal is of the form `0x00<nn>`, where `<nn>` represents valid data. meaning that each word address as seen by each master addresses a different word on the slave.

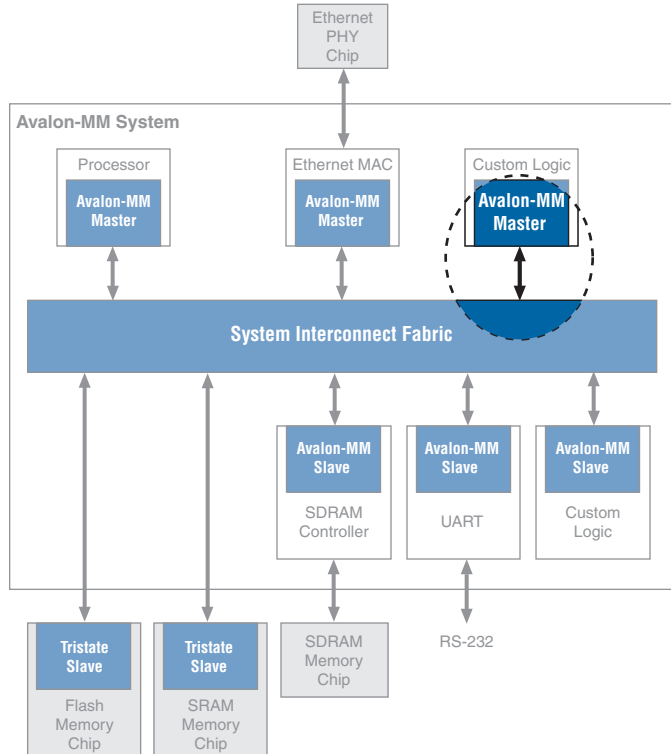
With native addressing, the effective address map of the slave is dependent on the master that is accessing it, and in some cases, the address span of the slave changes as masters are added to the system. In many cases, extra logic is required to handle accesses from different masters, leading to increased logic usage and performance degradation. Native addressing is now deprecated, meaning that it is still supported by the system interconnect fabric, but is not recommended for new components.



### 3.7. Masters

This section defines the behavior of Avalon-MM master transfers between a master and the system interconnect fabric as shown in Figure 3.9.

**Figure 3.9. Focus of Avalon-MM Master Transfers**



The signal types available for Avalon-MM masters allow you to create masters that use bursts for both reads and writes. Because the system interconnect fabric creates point-to-point connections between master and slave pairs, you can increase the throughput of your system by initiating reads with multiple pipelined slave peripherals. In responding to reads, when a slave peripheral has valid data it asserts `readdatavalid` and the system interconnect fabric enables the connection between the master and slave pair.

The following sections provide details of the signal types available for Avalon-MM masters and provide timing diagrams that detail these transfers.

### 3.8. Master Signal Types

Table 3.4 lists the signal types that constitute the Avalon-MM interface for master ports.

<b>Table 3.4. Avalon-MM Master Signals (1) (Part 1 of 4)</b>				
<b>Signal Type</b>	<b>Width</b>	<b>Direction</b>	<b>Req'd</b>	<b>Description</b>
<b>Fundamental Signals</b>				
address	1-32	Out	Yes	The address signal represents a byte address regardless of the data-width of the master. The value of the address must be aligned to the data width. To write to specific bytes within a data word, the master must use the <code>byteenable</code> signal.  Masters always issue byte addresses, regardless of the data width of the master or slave port. The system interconnect fabric translates this address into a word address in the slave's address space so that each slave access is for a word of data from the perspective of the slave.
read read_n	1	Out	No	Read request signal from the master. Not required if the master never performs read transfers. If present, <code>readdata</code> must also be present.
readdata	8,16,32,64, 128, 256, 512, 1024	In	No	Data signal for read transfers.
write write_n	1	Out	No	Write request signal from the master. Not required if the master never performs write transfers. If present, <code>writedata</code> must also be used.
writedata	8,16,32,64, 128, 256, 512, 1024	Out	No	Data signal from the master for write transfers. Not required if the master never performs write transfers. If <code>readdata</code> is also present, <code>readdata</code> and <code>writedata</code> must be the same width.

**Table 3.4. Avalon-MM Master Signals (1) (Part 2 of 4)**

Signal Type	Width	Direction	Req'd	Description														
byteenable byteenable_n	1, 2, 4, 8, 16, 32, 64, 128	Out	No	<p>Enables specific byte lanes during transfers on ports of width greater than 8 bits. Each bit in <code>byteenable</code> corresponds to a byte lane in <code>writedata</code> and <code>readdata</code>. The master bit <i>N</i> of <code>byteenable</code> indicates whether byte <i>N</i> is being written to. During writes, <code>byteenables</code> specify which bytes to write to. Other bytes should be ignored by the slave. During reads, <code>byteenables</code> indicates which bytes the master is reading.</p> <p>When more than one byte lane is asserted, all asserted lanes must be adjacent. The number of adjacent lines must be a power of 2, and the specified bytes must be aligned on an address boundary for the size of the data. The are legal values for a 32-bit slave:</p> <table> <tr> <td>1111</td> <td>write full 32 bits</td> </tr> <tr> <td>0011</td> <td>writes lower 2 bytes</td> </tr> <tr> <td>1100</td> <td>writes upper 2 bytes</td> </tr> <tr> <td>0001</td> <td>writes byte 0 only</td> </tr> <tr> <td>0010</td> <td>write byte 1 only</td> </tr> <tr> <td>0100</td> <td>write byte 2 only</td> </tr> <tr> <td>1000</td> <td>write byte 3 only</td> </tr> </table>	1111	write full 32 bits	0011	writes lower 2 bytes	1100	writes upper 2 bytes	0001	writes byte 0 only	0010	write byte 1 only	0100	write byte 2 only	1000	write byte 3 only
1111	write full 32 bits																	
0011	writes lower 2 bytes																	
1100	writes upper 2 bytes																	
0001	writes byte 0 only																	
0010	write byte 1 only																	
0100	write byte 2 only																	
1000	write byte 3 only																	
waitrequest waitrequest_n	1	In	Yes	<p>Forces the master to wait until the system interconnect fabric is ready to proceed with the transfer. At the start of all transfers, a master initiates the transfer, and waits until <code>waitrequest</code> is deasserted. Masters must keep its control signals the same on subsequent cycles if <code>waitrequest</code> is asserted</p>														

<b>Table 3.4. Avalon-MM Master Signals (1) (Part 3 of 4)</b>				
<b>Signal Type</b>	<b>Width</b>	<b>Direction</b>	<b>Req'd</b>	<b>Description</b>
arbiterlock arbiterlock_n	1	Out	No	<p>arbiterlock ensures that once a master wins arbitration, it maintains access to the slave for multiple transfers. It is de-asserted coincident with read or write and with the deassertion of the last locked transfer read or write signal.</p> <p>Arbiterlock assertion does not guarantee that arbitration will be won, but after the arbiterlock-asserting master has been granted, it retains grant until it deasserts arbiterlock, whether or not it is making an access.</p> <p>Burst masters cannot use the arbiterlock signal. Arbitration priority values for arbiterlock-equipped masters are ignored.</p> <p>arbiterlock is particularly useful for read-modify-write operations, where master A reads 32-bit data that has multiple bitfields, changes one field, and writes the 32-bit data back. If master B were to able to write between the read and the write, master A's write would undo what master B had done.</p> <p>A master that asserts arbiterlock indefinitely blocks all other masters, causing a deadlock.</p>
<b>Pipeline Signals</b>				
readdatavalid readdatavalid_n	1	In	No	For pipelined read transfers with latency. Indicates that valid data is present on the readdata lines. Required if the master supports pipelined reads.
flush flush_n	1	Out	No	Used for pipelined read transfers. The master port asserts flush with a new read or write command to indicate that read responses from all previous read transfers are to be dropped to clear any pending read transfers in the pipeline.
<b>Burst Signals</b>				
burstcount	1-32	Out	No	Used by bursting masters to indicate the number of transfers in each burst.

**Table 3.4. Avalon-MM Master Signals (1) (Part 4 of 4)**

Signal Type	Width	Direction	Req'd	Description
<b>Reset Signals</b>				
resetrequest resetrequest_n	1	Out	No	Asserted by the master to request a reset the entire system.

*Note to Table 3.4:*

- (1) All Avalon signals are active high. Avalon signals that can also be asserted low list an *\_n* version of the signal in the Signal Type column.

### 3.9. Master Interface Properties

Table 3-5 describes the interface properties for an Avalon-MM master interface.

**Table 3-5. Avalon-MM Master Interface Properties (Part 1 of 2)**

Name	Default Value	Legal Values	Description
burstOnBurstBoundariesOnly	false	true,false	If true, the master guarantees that all bursts will begin on a multiple of the burst size.
linewrapBursts	false	true,false	Some memory devices implement a wrapping burst instead of an incrementing burst. The difference between the two is that with a wrapping burst, when the address reaches a burst boundary, the address wraps back to the previous burst boundary such that only the low order bits need to be used for address counting. A wrapping burst with burst boundaries every 32 bytes across a 32-bit interface to address 0xC would write to addresses 0xC, 0x10, 0x14, 0x18, 0x1C, 0x0, 0x4, and 0x8.
maxBurstSize	1	64	The maximum burst size that a master can send.

**Table 3–5. Avalon-MM Master Interface Properties (Part 2 of 2)**

Name	Default Value	Legal Values	Description
doStreamReads	false	true,false	Indicates that the master wishes to be held off with the <code>waitrequest</code> signal whenever it reads from a slave that has <code>dataavailable</code> deasserted.
doStreamWrites	false	true,false	Indicates that the master wishes to be held off with the <code>waitrequest</code> signal whenever it writes to a slave that has <code>readyfordata</code> deasserted.

### 3.10. Master Transfers

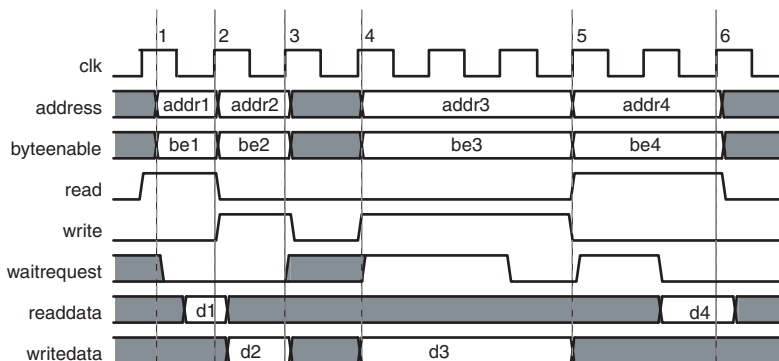
A typical transfer is initiated by the master and transfers a word of data. When necessary, `waitrequest` is asserted to stall the master until the transfer can be accepted. The transfer terminates when `waitrequest` is deasserted.

If `waitrequest` is asserted for  $N$  cycles, then the total transfer takes  $(N + 1)$  cycles. The system interconnect fabric does not provide a time-out; the master must stall for as long as `waitrequest` remains asserted.

A master can use the `byteenable` signal to indicate that it only requires data for specific bytes of `readdata` or to write specific bytes of `writedata`. If a master port does not have a `byteenable` signal, the transfer proceeds as if all `byteenable` are asserted.

A master transfer starts on the rising edge of `clk`. During the first cycle, the master asserts the address, `byteenable`, and the read or write signals. If `waitrequest` is asserted, the master must hold all outputs constant through the next cycle. The transfer ends on the first rising clock edge with a deasserted `waitrequest`, and the master may initiate another transfer immediately.

Figure 3.10 shows a typical master transfers.

**Figure 3.10. Fundamental Master Read and Write Transfers****Notes to Figure 3.10:**

- (1) The master starts a read by asserting address, byteenable and read. readdata is returned during the first cycle.
- (2) The master captures readdata and deasserts read, ending the transfer. It immediately asserts address, byteenable, writedata, and write for the next transfer.
- (3) waitrequest is not asserted at the rising edge of clk, so the write transfer completes.
- (4) The master asserts valid address, byteenable, writedata and write beginning a second write transfer. waitrequest is asserted, so the master holds all outputs.
- (5) waitrequest is not asserted so the write transfer completes. The master asserts address, byteenable and read for the next transfer. waitrequest is asserted. The master holds all outputs.
- (6) waitrequest is not asserted at the rising edge of clk, so the read transfer completes.

### 3.10.1. Master Pipelined Read Transfer

A master that supports pipelined reads can initiate a new read transfer before it receives data from a previous transfer. To support pipeline reads, a master includes the one-bit input signal `readdatavalid`. `readdatavalid` is asserted to indicate that `readdata` is valid data in response to a previous read.

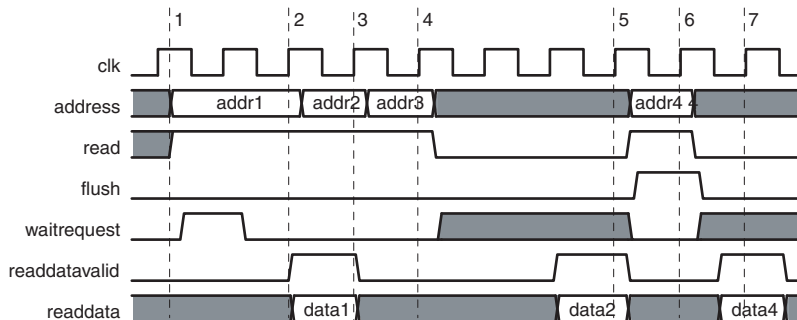
The timing and sequence of signals during the address phase is identical to that of the fundamental Avalon-MM master read transfer, except for the `readdata` signal. The master must present `read`, `address`, and `byteenable`, and must hold these signals constant as long as `waitrequest` is asserted. Once `waitrequest` is deasserted, the master can initiate another read or write transfer.

For pipelined transfers, `readdata` is returned some number of cycles later. `readdata` is always returned in the same order as the reads were issued by the master. There is no limit on the time until `readdatavalid` is asserted. Pipelined masters can have an arbitrary number of read transfers pending at any given time.

Pipelined masters can optionally use the `flush` signal, which is provided for cases in which a master peripheral determines that it does not need the data for all currently pending transfers. Flushing the pipeline is a common requirement for pipelined CPUs that prefetch instructions before knowing if the instructions are valid or not. When the master port asserts `flush` on the rising edge of `clk`, `readdatavalid` is cancelled for all pending reads. The master port can initiate a new read transfer during the same clock cycle that `flush` is asserted. In this case, the data corresponding to this transfer becomes the next valid data to be returned on `readdata`.

Figure 3.11 shows several pipelined master read transfers. This example demonstrates that the master must respond appropriately to both `waitrequest` and `readdatavalid`. In this example, the second-to-last transfer is flushed using the `flush` signal. However, the unwanted data might have appeared on `readdata` if the latency for that transfer were shorter.

**Figure 3.11. Master Pipelined Read Transfer**



**Notes to Figure 3.11:**

- (1) The master initiates a read transfer by presenting `addr1` and asserting `read`. `waitrequest` is asserted so the master port waits and asserts `addr1` and `read` for another cycle.
- (2) The system interconnect fabric deasserts `waitrequest` accepting the read command.
- (3) The system interconnect fabric accepts a second read command. `readdatavalid` is asserted, so the master captures valid `readdata` (`data1`), in response to the first read command.
- (4) The system interconnect fabric accepts a third command, making a total of two pending transfers.
- (5) `readdatavalid` is asserted, so master captures valid `readdata` (`data2`).
- (6) `readdatavalid` is not asserted, so master does not capture `readdata`. Master asserts `flush`, causing pending transfer (`addr3`) to be dropped.
- (7) `readdatavalid` is asserted, so the master captures valid `readdata` (`data4`).



### 3.10.2. Burst Transfers

A burst transfer guarantees that a master is granted uninterrupted access to a target slave for the duration of the burst. Once a burst begins no other master can access the slave port until the burst completes.

Avalon-MM bursts do not guarantee that a master or slave sustains one transfer per cycle during the burst, they only guarantee that arbitration between the master-slave pair remains locked throughout the burst. To support master read bursts, a master must also support pipelined transfers.

For an Avalon-MM master, `burstcount` is an output signal used to indicate the length of the burst. At the start of each burst, a master asserts a valid `address` and a burst length value on `burstcount`, measured in word transfers. The master presents only one address for each burst; the addresses for all subsequent transfers in the burst are inferred by the slave.

When a master starts a burst with an address of  $A$  and a `burstcount` value of  $B$ , it is committing to  $B$  consecutive transfers starting at address  $A$ . The burst does not complete until the master transfers  $B$  units of data. A master cannot abort the burst without first exhausting remaining transfers in the current burst. The master can issue a new read burst before the data for the previous burst has been returned.

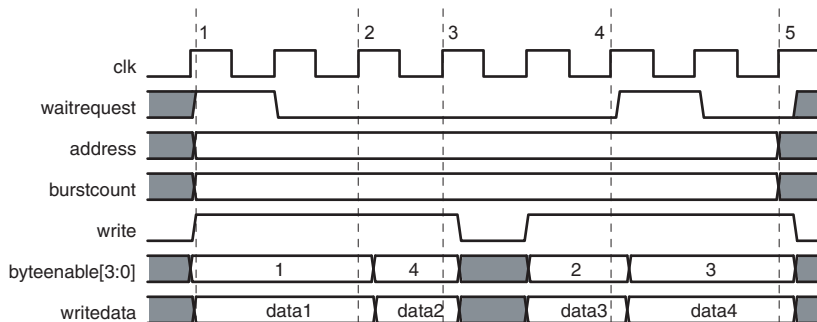
#### 3.10.2.1. Master Write Bursts

To start a write burst the master port asserts `address`, `writedata`, `write`, `byteenable`, and `burstcount`. If `waitrequest` is deasserted, `address`, `burstcount`, and the first unit of `writedata` are captured on the rising edge of `clk`. The master must hold constant values on `address` and `burstcount` throughout the write burst.

The following rules apply to burst transfers:

- The master can pause a write burst without ending it by deasserting `write`.
- When `waitrequest` is asserted, the master must hold `byteenable`, `writedata`, `write`, and `address` constant.

Figure 3.12 demonstrates an example of a master write burst of length 4.

**Figure 3.12. Master Write Burst****Notes to Figure 3.12:**

- (1) The master begins a burst of 4 transfers. `waitrequest` is asserted, pausing the burst and causing the master to hold all outputs constant.
- (2) Because `waitrequest` is deasserted, the first write transfer is accepted by the system interconnect fabric.
- (3) The second `writedata` (`data2`) is accepted. The master then deasserts `write`, pausing the burst.
- (4) The system interconnect captures `writedata` (`data3`) and then the master presents the last unit of `writedata` (`data4`) `waitrequest` pauses the burst again.
- (5) `waitrequest` is deasserted and the last unit of `writedata` (`data4`) is captured on the next rising edge of `clk` ending the burst.

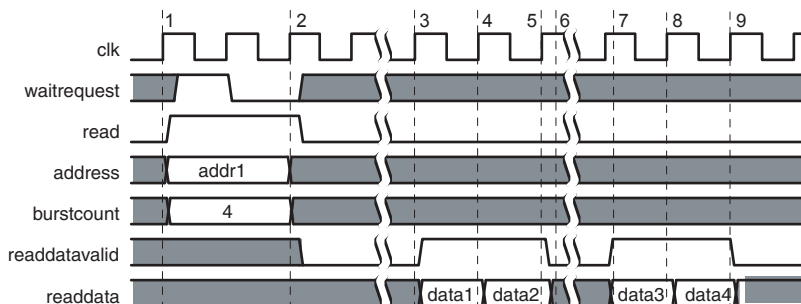
**3.10.2.2. Master Read Bursts**

Read bursts are a form of pipelined read transfer. In contrast to non-burst pipelined read transfers, a single read burst transfer corresponds to multiple data transfers. To start a read burst, the master asserts `address`, `read`, and `burstcount`. When `waitrequest` is deasserted, the address phase ends.

The data phase consists of a number of words of data being provided on `readdata`, with `readdatavalid` asserted to mark valid cycles. The burst data phase is complete once the number of words transferred is equal to the value provided by `burstcount`. `readdatavalid` may be deasserted at any time, pausing the transfer. The master cannot pause the data phase. The following rules apply when a master starts a read burst:

- Unless `flush` is asserted, if the master specifies `burstcount` of  $N$ , the master is guaranteed to see `readdatavalid` for  $N$  cycles to complete the burst.
- The master must capture `readdata` whenever `readdatavalid` is asserted. Each value of `readdata` is valid for a single clock cycle.
- The master must hold constant all `byteenable` lines throughout the burst address phase.

Figure 3.13 demonstrates a master read burst of length 4.

**Figure 3.13. Master Read Burst****Notes to Figure 3.13:**

- (1) The master asserts address, burstcount, and read. In this example, burstcount is 4. waitrequest is asserted for one cycle, pausing the transfer.
- (2) address and burstcount are captured. The master could begin a new transfer on the following cycle.
- (3) readdata and readdatavalid are presented.
- (4) Master captures the first unit of readdata (data1).
- (5) Master captures the next unit of readdata (data2).
- (6) readdatavalid is deasserted, pausing the burst. readdatavalid can be deasserted for an arbitrary number of clock cycles.
- (7) The system interconnect fabric presents valid readdata, and asserts readdatavalid again.
- (8) The master captures the next unit of readdata (data3).
- (9) The master captures the last unit of readdata (data4), ending the burst.



Interrupt interfaces allow slave components to signal events to master components. For example, a DMA controller can interrupt a processor when it has completed a DMA transfer.

### 4.1. Interrupt Sender

An interrupt sender drives a single interrupt signal to an interrupt receiver. The timing of the `irq` signal must be synchronous to the rising edge of its associated clock, but has no relationship to any transfer on any other interface. `irq` must be asserted until the interrupt has been acknowledged on the associated Avalon Memory-Mapped (Avalon-MM) slave interface.

The interrupt receiver typically determines how to respond to the event by reading an interrupt status register from an Avalon-MM slave interface. The mechanism used to acknowledge an interrupt is component specific.

#### 4.1.1. Signal Types

Table 4.1 lists the interrupt signal types.

<i>Table 4.1. Interrupt Sender Signal Types</i>				
Signal Type	Width	Direction	Required	Description
<code>irq</code> <code>irq_n</code>	1	Output	Yes	Interrupt Request. A slave asserts <code>irq</code> when it needs to be serviced.

## 4.1.2. Interrupt Sender Properties

Table 4.2 lists the properties associated with interrupt senders.

Property Name	Default Value	Legal Values	Description
<code>associatedClockReset</code>	—	Name of clock interface on this component.	The name of the clock interface that this interrupt sender is synchronous to. The sender and receiver may have different values for this property.
<code>associatedAddressablePoint</code>	—	Name of Avalon-MM slave on this component.	The name of the Avalon-MM slave that provides access to the registers that should be accessed to service the interrupt.

## 4.2. Interrupt Receiver

An interrupt receiver interface receives interrupts from interrupt sender interfaces. Components with an Avalon-MM master interface can include an interrupt receiver to detect interrupts asserted by slave components with interrupt sender interfaces. Interrupt receiver interfaces support two interrupt schemes:

- *Individual requests*—the interrupt receiver expects to see each interrupt request from each interrupt sender as a separate bit and is responsible for determining the relative priority of the interrupts,
- *Priority encoded*—the interrupt receiver expects to see a single-bit irq signal and a six-bit interrupt number signal that indicates the number of the highest priority interrupt currently being asserted. Interrupt zero is the highest priority. There can only be one interrupt sender at each priority for a total of 64 senders in a system.

## 4.2.1. Interrupt Receiver Properties

Table 4.3 lists the properties associated with interrupt receivers.

Property Name	Default Value	Legal Values	Description
irqScheme	individualRequests	individualRequests, priorityEncoded	Selects one of the two interrupt encoding schemes.
associatedAddressablePoint	—	The name of Avalon-MM slave on this component.	The name of the Avalon-MM slave that provides access to the registers that should be cleared after the interrupt is serviced.

## 4.2.2. Signal Types

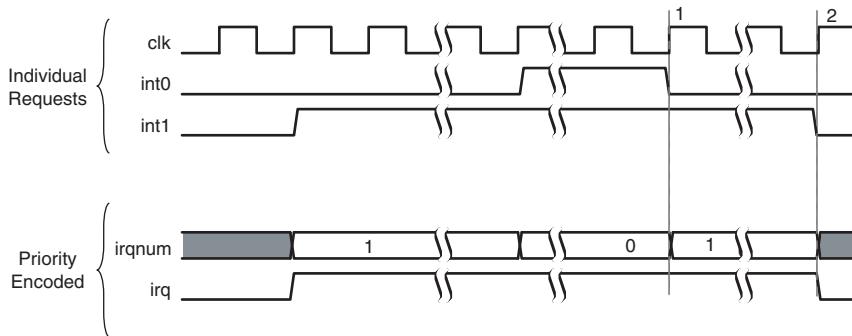
Table 4.4 lists the interrupt receiver signal types.

Signal Type	Width	Direction	Required	Description
irq	1–32	Input	Yes	Indicates when one or more slave ports have requested an interrupt. If irqScheme=individualRequests, irq is an n-bit vector, where each bit corresponds directly to one IRQ sender, with no inherent assumption of priority.  If irqScheme=priorityEncoded, irq is a one bit logical OR of all connected interrupt sender signals.
irqnumber	6	Input	No	Only used when irqScheme = priorityEncoded. irqnumber indicates the current highest priority interrupt.

## 4.2.3. Interrupt Timing

Figure 4.1 illustrates interrupt timing using both individual requests and priority encoding. In both cases, the Avalon-MM master services the priority 0 interrupt before the priority 1 interrupt.

**Figure 4.1. Interrupt Timing for Individual Request and Priority Encoded Interrupts**



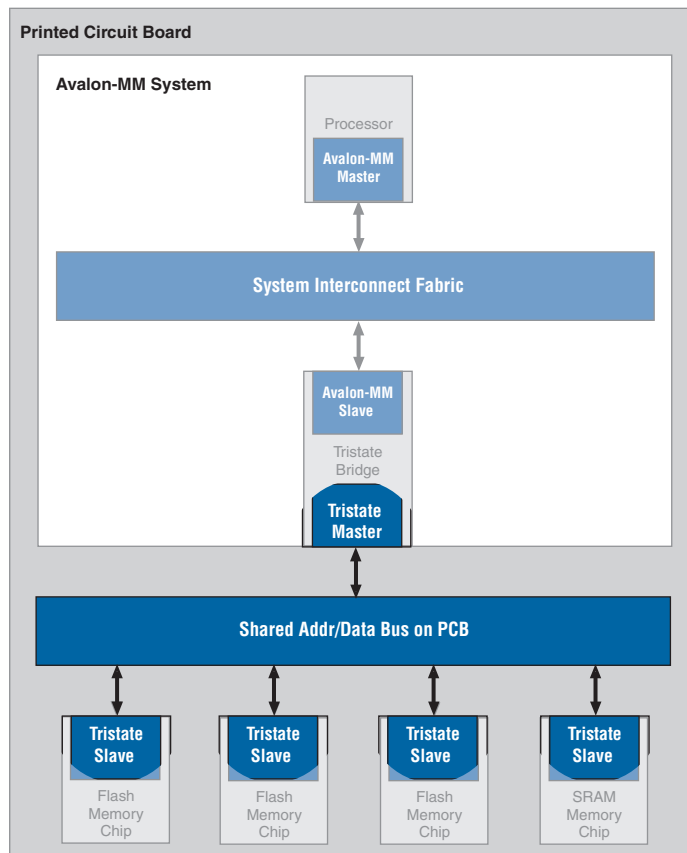
**Notes to Figure 4.1:**

- (1) Interrupt 0 serviced.
- (2) Interrupt 1 serviced.



Avalon Memory-Mapped (Avalon-MM) tristate slave interfaces allow Avalon-MM masters to drive off-chip devices. The interface allows data and address pins to be shared across multiple tristate devices. Sharing is valuable in systems that have multiple external memory devices and limited pins. Figure 5.1 shows a typical example where multiple flash memories and an SRAM device are connected to the FPGA through a tristate bridge. The Avalon-MM tristate interface is required for these external devices to share pins.

**Figure 5.1. Typical Use of Avalon-MM Tristate Interface**



## 5.1. Tristate Slave Signal Types

Tristate slave ports use the bidirectional signal data rather than the separate, unidirectional signals `readdata` and `writedata`. Avalon-MM tristate ports must also use the `outputenable` signal. Table 5.1 lists the Avalon-MM tristate signal types

Signal Type	Width	Direction	Req'd	Description
<code>address</code>	1-32	In	No	Address lines to the slave port. Specifies a byte offset into the slave's address space.
<code>read</code> <code>read_n</code>	1	In	No	Read-request signal. Not required if the slave port never outputs data. If present, <code>data</code> must also be used.
<code>write</code> <code>write_n</code>	1	In	No	Write-request signal. Not required if the slave port never receives data from a master. If present, <code>data</code> must also be present, and <code>writebyteenable</code> cannot be present.
<code>chipselct</code> <code>chipselct_n</code>	1	In	No	When present, the slave port ignores all Avalon-MM signals unless <code>chipselct</code> is asserted. <code>chipselct</code> is always present in combination with <code>read</code> or <code>write</code> .
<code>outputenable</code> <code>outputenable_n</code>	1	In	Yes	Output-enable signal. When deasserted, a tristate slave port must not drive its data lines otherwise data contention may occur.
<code>data</code>	8, 16, 32, 64, 128, 256, 512, 1024	Bidir	No	Bidirectional data. During <code>write</code> transfers, the FPGA drives the <code>data</code> lines. During <code>read</code> transfers the slave device drives the <code>data</code> lines, and the FPGA captures the <code>data</code> signals and provides them to the master.

**Table 5.1. Avalon-MM Tristate Slave Signals (1)**

Signal Type	Width	Direction	Req'd	Description
byteenable byteenable_n	2,4,8, 16, 32, 64, 128	Out	No	Enables specific byte lane(s) during transfers. Each bit in <code>byteenable</code> corresponds to a byte lane in <code>data</code> . During writes, <code>byteenables</code> specify which bytes the master is writing to the slave. During reads, <code>byteenables</code> indicates which bytes the master is reading. Slaves that simply return <code>data</code> with no side effects are free to ignore <code>byteenables</code> during reads. When more than one byte lane is asserted, all asserted lanes are guaranteed to be adjacent. The number of adjacent lines must be a power of 2, and the specified bytes must be aligned on an address boundary for the size of the data. The are legal values for a 32-bit slave: 1111           write full 32 bits 0011           writes lower 2 bytes 1100           writes upper 2 bytes 0001           writes byte 0 only 0010           write byte 1 only 0100           write byte 2 only 1000           write byte 3 only
writebyteenable writebyteenable_n	2,4,8, 16, 32, 64, 128	In	No	Equivalent to the logical AND of the <code>byteenable</code> and <code>write</code> signals. When used, the <code>write</code> signal is not used.
begintransfer	1	In	No	Asserted for the first cycle of each transfer.

**Note to Table 5.1:**

- (1) All Avalon signals are active high. Avalon signals that can also be asserted low list both versions in the **Signal Type** column.

### 5.1.1. address Behavior

For Avalon-MM tristate slaves, the address signal represents a byte address. The address signal can be shared among multiple off-chip devices which have differing data widths. If the Avalon-MM tristate slave port data width is greater than one byte, it is necessary to correctly map the address signals from the system interconnect fabric to the address lines on the slave peripheral.

Table 5.2 specifies which Avalon-MM `address` line corresponds to A0 (the least-significant address line) on the external device for a number of data widths.

<b>Data Width of External Device</b>	<b>External Device Address LSB Connects to</b>
8	<code>address[0]</code> of Avalon-MM address
16	<code>address[1]</code> of Avalon-MM address
32	<code>address[2]</code> of Avalon-MM address
64	<code>address[3]</code> of Avalon-MM address

For example, when connecting the system interconnect fabric to a 32-bit memory device using an Avalon-MM tristate slave interface, the two least-significant bits of the Avalon-MM `address` signal do not connect to the address lines on the memory chip. Avalon-MM `address[2]` connects to the device's A0 pin, `address[3]` connects to the A1 pin, and so forth.

### 5.1.2. outputenable and read Behavior

The system interconnect fabric asserts the `outputenable` signal during read transfers only. When a port's `outputenable` is deasserted, the data lines may be active with signals for a write transfer or with signals from some other peripheral that shares the data signals. Therefore, it is critical for the slave peripheral to tristate its data lines any time `outputenable` is deasserted.

### 5.1.3. write\_n and writebyteenable Behavior

If a memory device has a combined R/Wn pin, the Avalon-MM signal `write_n` can be connected to a read/write (R/Wn) pin. `write_n` is only asserted during write transfers, and remains deasserted (i.e., in read mode) at all other times. In this case, the Avalon-MM `outputenable_n` signal connects to the output enable pin on the external device, and the Avalon-MM `write_n` signal connects to the R/Wn pin.

Some synchronous memory devices use individual write-enable signals for each byte lane (such as `BWn1`, `BWn2`, `BWn3`, and `BWn4`). The Avalon-MM port `writebyteenable` is the logical AND of the `write` and `byteenable` signals, and can be connected directly to such `BWn` pins.

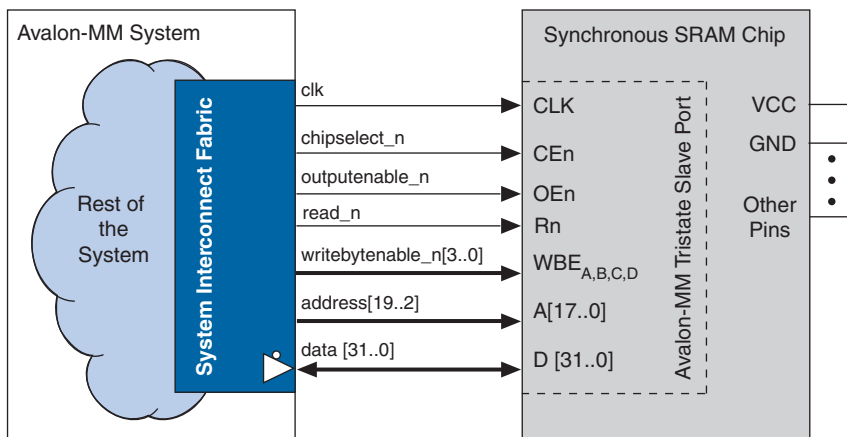
### 5.1.4. Interfacing to Synchronous Off-Chip Memory

Avalon-MM tristate slaves can write data to off-chip synchronous memory devices, such as SRAM and ZBT RAM. The hold time property is used to keep data asserted several clock cycles after `write` is deasserted.

Pipelined read transfers are supported if the component has fixed read latency. Pending pipelined read transfers are completed before initiating new write transfers to prevent possible signal contention. As a result, Avalon-MM tristate slaves might not achieve the maximum possible throughput when performing back-to-back read-write transfer sequences.

Figure 5.2 shows an example of the connections between the system interconnect fabric and a synchronous, 32-bit memory. In this example, the Avalon-MM tristate slave port is pipelined to accommodate the synchronous memory. The port uses separate `read_n` and `outputenable_n` signals. The chip in this example uses the `writebyteenable` signal for its four byte lanes. This chip has an 18-bit address. Note that the lower two bits of the 20-bit Avalon-MM address signal specify a byte address, and therefore do not connect to the chip's address lines.

Figure 5.2. Connection to Synchronous Memory Chip



## 5.2. Tristate Slave Properties

Table 5–3 lists the properties of Avalon-MM tristate slave interfaces. These include all the properties for slave interfaces defined in [Chapter 3, Avalon Memory-Mapped Interfaces](#) plus some additional properties to support off-chip devices.

**Table 5–3. Avalon-MM Tristate Interface Properties**

Name	Default Value	Legal Values	Description
readLatency	0	num_cycles	Read latency for fixed-latency slaves. Refer to <a href="#">Figure 5.5</a> for an illustration of this property.
writeLatency	0	num_cycles	Delay in cycles between acceptance of a write access and acceptance of valid writedata.
timingUnits	cycles	cycles, nanoseconds	Specifies the units for <code>setupTime</code> , <code>holdTime</code> , <code>writeWaitTime</code> and <code>readWaitTime</code> . Use cycles for synchronous devices and nanoseconds for asynchronous devices.
writeWaitTime	0	0–1000	Specifies additional time in units of <code>timingUnits</code> for write to be asserted.
holdTime	0	—	Specifies time in <code>timingUnits</code> between the deassertion of <code>write</code> and the deassertion of <code>chipselct</code> , <code>address</code> , and <code>data</code> . (Only applies to write transactions.)
readWaitTime	1	0–1000	Specifies additional time in units of <code>timingUnits</code> for read to be asserted.
setupTime	0	—	Specifies time in <code>timingUnits</code> between the assertion of <code>chipselct</code> , <code>address</code> , and <code>data</code> and assertion of <code>read/write</code> .
activeCSThroughRead Latency	false	true,false	If true, <code>chipselct</code> is asserted while <code>readdata</code> is pending.
associatedClockReset	—	—	Name of the clock interface that this tristate interface is synchronous to.

## 5.3. Slave Transfers

This section illustrates slave transfers that are specific to the Avalon-MM tristate interface.

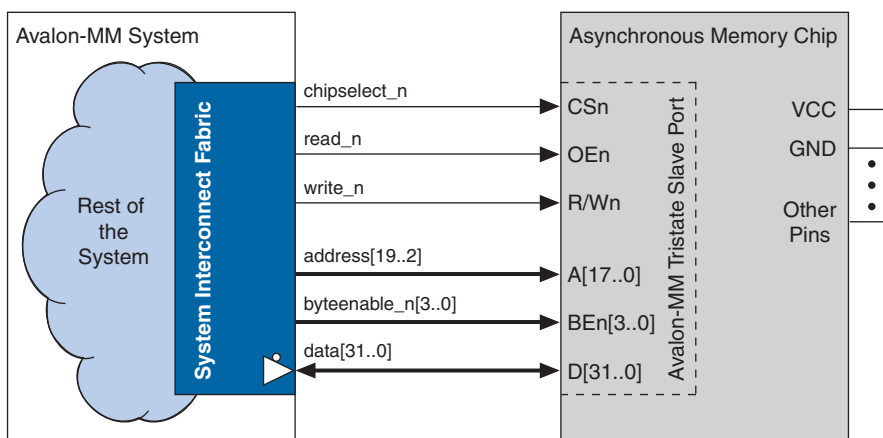
### 5.3.1. Asynchronous Transfers

[Figure 5.3](#) illustrates connections to an asynchronous memory chip. This chip has an 18-bit address and 4 byte-enable lanes. Note that the lower 2 bits of the 20-bit Avalon-MM address are not connected to the chip's address lines. For Avalon-MM tristate ports without pipelining, the read

signal and the `outputenable` signal are identical. Therefore, the Avalon-MM signal `read_n` can connect directly to both an external device's output enable pin (`OE_n`) and read-enable pin (`READ_n`).

When connecting directly to asynchronous off-chip devices with an Avalon-MM tristate slave port, the `clk` signal is not needed. Instead, pulses on the `chipselect`, `read`, and/or `write` signals synchronize the transfer, using the defined setup and hold times. All output signals are glitch-free throughout the transfer. Even though the timing units may be specified in nanoseconds, the system interconnect fabric is always synchronous, and it toggles and captures signals only at integer multiples of the clock period.

**Figure 5.3. Connection to Asynchronous Memory Chip**



#### 5.3.1.1. Setup Time

Some peripherals, require `address` and `chipselect` signals to be stable for a period of time before the `read` signal is asserted. Avalon-MM transfers with `setupTime` accommodate such requirements.

A nonzero setup time of means that after `address` and `chipselect` are asserted, there is a delay before `read` or `write` is asserted. The total number of cycles to complete the transfer depends on setup and wait time. For example, a slave port with 2 cycles of setup time and 3 cycles of wait time takes 6 cycles to complete the transfer: 2 setup cycles, plus 3 wait-state cycles, plus 1 cycle to capture data. Setup time is applied equally to both read and write transfers.

### 5.3.1.2. Hold Time

A nonzero hold time of  $N$  means that, after `write` is deasserted, `address`, `byteenable`, `writedata`, and `chipselct` remain constant for  $N$  more cycles. Hold time only applies to write transactions. The total number of cycles to complete the transfer depends on setup, wait-state, and hold cycles. For example, a slave port with 2 cycles of setup time, 3 cycles of write wait time, 2 cycles of hold time takes 8 cycles to complete the transfer: 2 setup cycles plus 3 wait time cycles plus 2 hold cycles plus 1 cycle to capture data.

A slave port does not have to use both setup and hold times.

### 5.3.1.3. Example Read and Write Using Setup, Hold and Wait Times

Figure 5.4 shows Avalon-MM tristate slave asynchronous read and write transfers, assuming a 50 MHz clock. This port uses the following Avalon-MM tristate properties:

- `timingUnits` is given in nanoseconds
- `setupTime` is 50 ns (3 clocks @ 50 MHz)
- `holdTime` is 10 ns (1 clock @ 50 MHz)
- `writeWaitTime` is 30 ns (2 clocks @ 50 MHz)
- `readWaitTime` is 30 ns (2 clocks @ 50 MHz)
- No pipelining

Note that when the wait time is expressed in nanoseconds, the read or write period, as seen on the FPGA pins, is as long as the specified wait time, rounded up to the next clock period. Table 5.4 illustrates this point.

Wait Time	Number of cycles
0 ns	1 cycle
10 ns	1 cycle
20 ns	1 cycle
21 ns	2 cycles

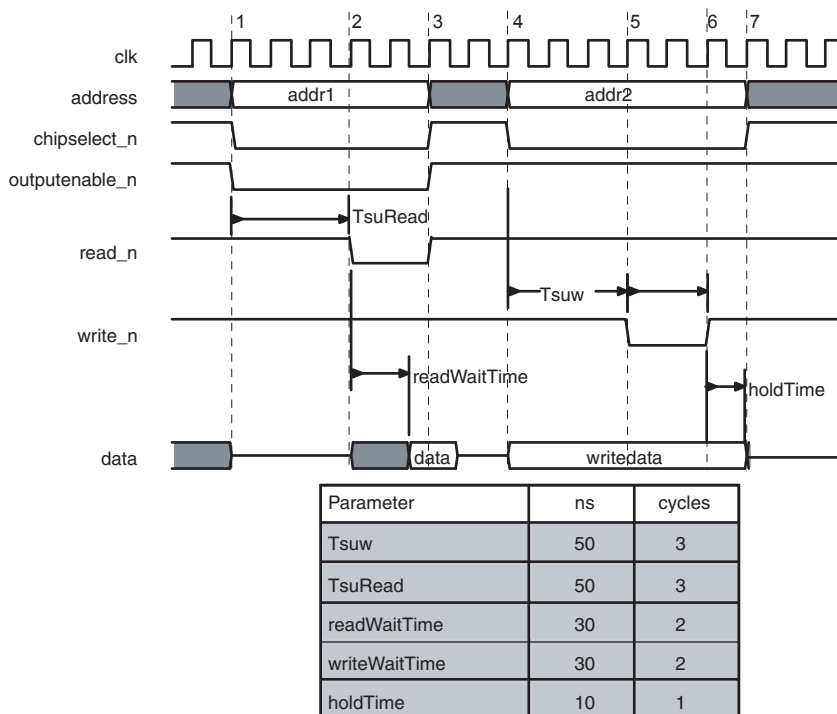


When the wait time is expressed as cycles, the number of cycles that the read or write signal is asserted is the value of `waitTime` plus one cycle for data capture.

<b>Wait Time</b>	<b>Number of cycles</b>
0 cycles	1 clock period
1 cycle	2 clock periods
2 cycles	3 clock periods

Figure 5.4 shows the tristate behavior for a single asynchronous memory. The data lines could be active at any time due to the transfer activity of other peripherals sharing the data and address signals. `clk` is shown only to illustrate the relationship between signals and the system clock; it is not connected to the asynchronous device.

**Figure 5.4. Tristate Slave Read and Write Transfers with Setup Time and Wait-States**



**Notes to Figure 5.4:**

- (1) The system interconnect fabric drives address and asserts chipselect\_n
- (2) After 3 cycles (from 50 ns) of setupTime, the system interconnect fabric asserts read\_n.
- (3) The slave port deasserts read\_n after 2 cycles (from 30 ns) of readWaitTime. Data is sampled at the rising clock edge.
- (4) address and writedata are driven.
- (5) write\_n is driven after 3 cycles (from 50 ns) setupTime.
- (6) write\_n is deasserted after two cycles (from 30 ns) of writeWaitTime.
- (7) address, chipselect, and the data bus stop being driven after 1 cycle (from 10 ns) of holdTime.

### 5.3.2. Synchronous Transfers

Synchronous read and write transfers are the same as for Avalon-MM interfaces described in [Chapter 3, Avalon Memory-Mapped Interfaces](#).

### 5.3.3. Pipelined Slave Read Transfers

The pipelined Avalon-MM tristate slave read transfer is suitable for connecting to off-chip synchronous memory devices, such as SSRAM. For Avalon-MM tristate ports with pipelining, read is asserted during the

address phase only and is deasserted through the data phase. `outputenable` is asserted before the final rising clock edge of the transfer, causing the peripheral device to drive its data pins. `outputenable` is deasserted when there are no pending read transfers. Avalon-MM slave tristate ports cannot be pipelined with variable latency. Only pipelined tristate ports with fixed latency are supported.

Some synchronous memory chips which use pipelined transfers require the `chipselct` signal to be asserted only during the address phase, while other chips require the chip select signal to be asserted until the entire transfer completes. The Avalon-MM tristate slave interface supports both cases, using the `activeCSThroughReadLatency` property.

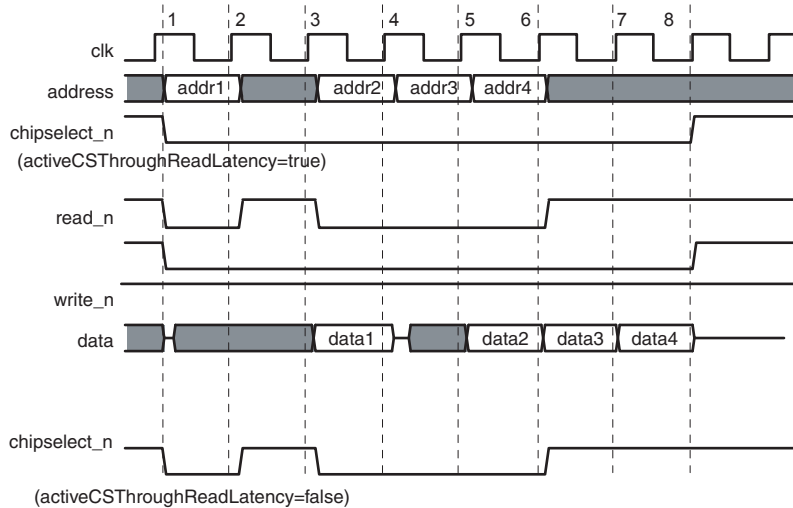
The tristate slave must declare which `chipselct` timing it supports according to the guidelines:

- When a tristate slave declares `activeCSThroughReadLatency` property to be true, `chipselct` is asserted throughout both the address and data phases of the read transfer. In this case, `chipselct` mirrors `outputenable`.
- When a port does not use the `activeCSThroughReadLatency` property, `chipselct` is only asserted during the address phase. In this case, `chipselct` mirrors `read`.

Figure 5.5 shows a pipelined Avalon-MM tristate slave read transfer. This port uses the Avalon-MM properties:

- `readLatency` is set to 2
- `writeLatency` is set to 2
- `activeCSThroughReadLatency` is shown for both the true and false settings

The diagram shows the behavior for one peripheral. However, the data lines could be active at any time due to the transfer activity of a different peripheral sharing the data and address signals.

**Figure 5.5. Pipelined Tristate Slave Read Transfers****Notes to Figure 5.5:**

- (1) `chipselect_n`, `addr1`, and `read_n` are asserted, initiating a read transfer. At this time `outputenable_n` is also asserted, so the slave peripheral can drive the data lines at any time.
- (2) The slave peripheral captures `addr1` and `read_n` on this rising edge of `clk`. The data phase begins, and the slave produces valid data two clock cycles later.
- (3) `read_n` is deasserted on this rising edge of `clk`, so the master isn't issuing a new read command. When `activeCSThroughReadLatency` is false, `chipselect_n` is deasserted, and the tristate slave must not drive the data bus.
- (4) `data1` is captured at this rising edge of `clk`. `chipselect_n`, `addr2`, and `read_n` are asserted initiating transfer 2.
- (5) The system interconnect fabric asserts `chipselect_n`, `addr3`, and `read_n` at this rising edge of `clk`, initiating transfer 3. Because `outputenable_n` is asserted, the slave peripheral could drive the data lines.
- (6) The system interconnect fabric captures `data2` at the rising edge of `clk`. `read_n` is deasserted, ending the sequence of read transfers. If `activeCSThroughReadLatency` is asserted `chipselect` remains asserted until all pending read transfers have completed, otherwise it is deasserted.
- (7) The system interconnect fabric captures `data3`.
- (8) The system interconnect fabric captures `data4`. There are no more pending transfers so `chipselect` and `outputenable_n` are deasserted, forcing the slave peripheral to stop driving its data lines.

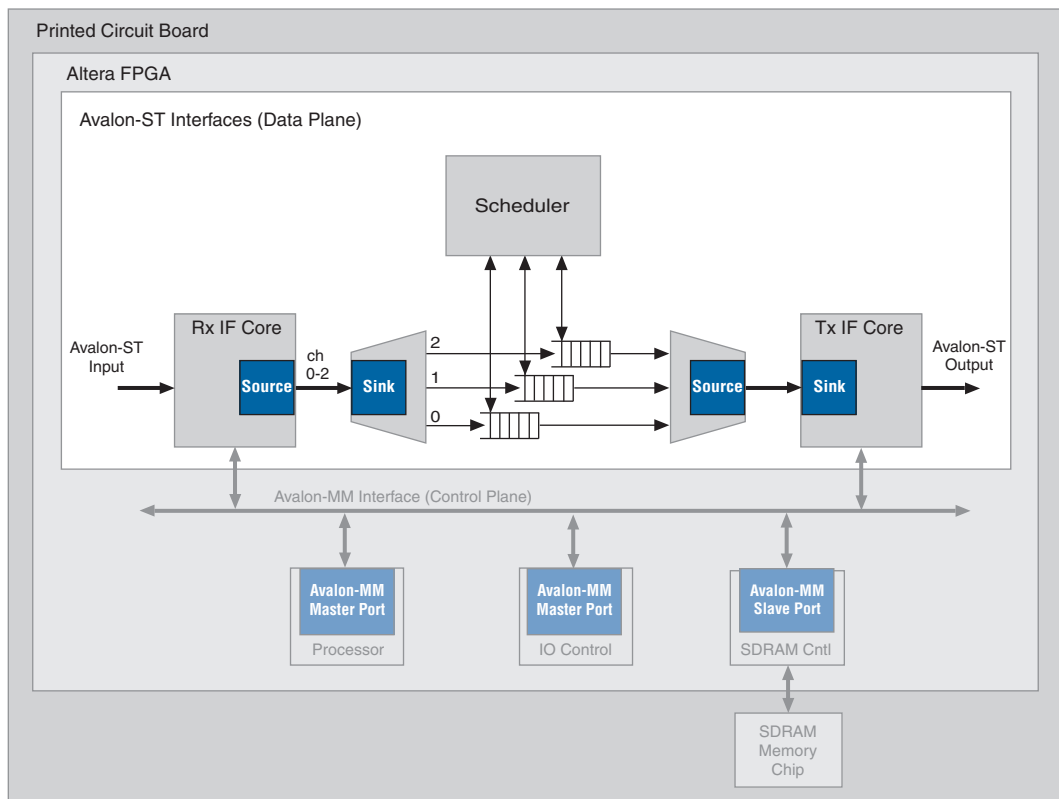
## 5.4. Master Transfers

Avalon-MM tristate slaves are mastered by Avalon-MM masters via a tristate bridge. Avalon-MM tristate masters are not supported on other components. For more information on Avalon-MM master refer to [Chapter 3, Avalon Memory-Mapped Interfaces](#).

## 6.1. Introduction

Avalon Streaming (Avalon-ST) interfaces are used for components that drive high bandwidth, low latency, unidirectional data. Typical applications include multiplexed streams, packets, and DSP data. The Avalon-ST interface signals can describe traditional streaming interfaces supporting a single stream of data without knowledge of channels or packet boundaries. The interface can also support more complex protocols capable of burst and packet transfers with packets interleaved across multiple channels. [Figure 6.1](#) illustrates a typical application of the Avalon-ST interface.

**Figure 6.1. Avalon-ST Interface - Typical Application**



All Avalon-ST source and sink interfaces are not necessarily interoperable. However, if two interfaces provide compatible functions for the same application space, adapter logic is available to allow them to interoperate.

### 6.1.1. Features

Some of the prominent features of the Avalon-ST interface are:

- Low latency, high throughput point-to-point data transfer
- Multiple channel support with flexible packet interleaving
- Sideband signaling of channel, error, and start and end of packet delineation
- Support for data bursting
- Automatic interface adaptation

### 6.1.2. Terms and Concepts

This section defines terms and concepts used in the Avalon-ST interface protocol.

- *Avalon Streaming System*—An Avalon Streaming System is a system that contains one or more Avalon-ST connections that transfer data from a source interface to a sink interface. The system shown in [Figure 6.1](#) consists of Avalon-ST interfaces to transfer data from the system input to output and Avalon Memory-Mapped (Avalon-MM) control and status register interfaces to allow software control.
- *Avalon Streaming Components*—A typical system using Avalon-ST interfaces combines multiple functional modules, called *components*. The system designer configures the components and connects them together to implement a system.
- *Source and Sink Interfaces and Connections*—When two components are connected, the data flows from the *source interface* to the *sink interface*. The combination of a source interface connected to a sink interface is referred to as a *connection*.
- *Backpressure*—Backpressure is a mechanism by which a sink can signal to a source to stop sending data. The sink typically uses backpressure to stop the flow of data when its FIFOs are full or when there is congestion on its output port. Support for backpressure is optional.

- *Transfers and Ready Cycles*—A transfer is an operation that results in data and control being propagated from a source interface to a sink interface. For data interfaces, a ready cycle is a cycle during which the sink can accept a transfer.
- *Symbol*—A symbol is the smallest atomic unit of data. For most packet interfaces, a symbol is a byte. One or more symbols make up the single unit of data transferred in a cycle.
- *Channel*—A channel is a physical or logical path or link through which information passes between two ports.
- *Packet*—A packet is an aggregation of data and control signals that is transmitted together. A packet may contain a header to help routers and other network devices direct the packet to the correct destination. The packet format is defined by the application, not this specification. Avalon-ST packets can be variable in length and can be interleaved across a connection. With an Avalon-ST interfaces, the use of packets is optional.

## 6.2. Avalon-ST Interface Signals

Each signal in an Avalon-ST source or sink interface corresponds to one Avalon-ST signal type; an Avalon-ST interface may contain only one instance of each signal type. All Avalon-ST signal types apply to both sources and sinks and have the same meaning for both.

Table 6.1 lists the signal types that comprise an Avalon-ST data interface.

Signal Type	Width	Direction	Required	Description
<b>Fundamental Signals</b>				
ready	1	Sink → Source	No	Asserted high to indicate that the sink can accept data. On interfaces supporting flow control, <code>ready</code> is asserted by the sink on cycle $N$ to mark cycle $N + \text{readyLatency}$ as a ready cycle, during which the source may assert <code>valid</code> and transfer data.  Sources without a <code>ready</code> input cannot be backpressured, and sinks without a <code>ready</code> output never need to backpressure.

<b>Table 6.1. Avalon-ST Interface Signals</b>				
<b>Signal Type</b>	<b>Width</b>	<b>Direction</b>	<b>Required</b>	<b>Description</b>
valid	1	Source → Sink	No	Asserted by the source to qualify all other source to sink signals. On ready cycles where <code>valid</code> is asserted, the data bus and other source to sink signals are sampled by the sink, and on other cycles are ignored.  Sources without a <code>valid</code> output implicitly provide valid data on every cycle that they're not being backpressured, and sinks without a <code>valid</code> input expect valid data on every cycle that they are not backpressuring.
data	1–256	Source → Sink	No	The <code>data</code> signal from the source to the sink, typically carries the bulk of the information being transferred.  The contents and format of the <code>data</code> signal is further defined by parameters.
channel	0–8	Source → Sink	No	The <code>channel</code> number for data being transferred on the current cycle.  If an interface supports the channel signal, it must also define the <code>maxChannel</code> parameter.
error	1–255	Source → Sink	No	A bit mask used to mark errors affecting the data being transferred in the current cycle. A single bit in <code>error</code> is used for each of the errors recognized by the component, as defined by the <code>errorDescriptor</code> property.
<b>Packet Transfer Signals</b>				
startofpacket	1	Source → Sink	No	Asserted by the source to mark the beginning of a packet.
endofpacket	1	Source → Sink	No	Asserted by the source to mark the end of a packet.
empty	0–8	Source → Sink	No	Indicates the number of symbols that are empty during cycles that contain the end of a packet. The <code>empty</code> signal is not used on interfaces where there is one symbol per beat. If <code>endofpacket</code> is not asserted, this signal is not interpreted.

### 6.2.1. Signal Polarity

All signal types listed in [Table 6.1](#) are active high.



## 6.2.2. Signal Sequencing and Timing

This section describes issues related to timing and sequencing of Avalon-ST signals.

### 6.2.2.1. Synchronous Interface

All transfers of an Avalon-ST connection occur synchronous to the rising edge of the associated clock signal. All outputs from a source interface to a sink interface, including the `data`, `channel`, and `error` signals, must be registered on the rising edge of clock. Inputs to a sink interface do not have to be registered. Registering signals at the source provides for high frequency operation while eliminating back-to-back registers with no intervening logic.

### 6.2.2.2. Clock Enables

Avalon-ST components typically do not include a clock enable input, because the Avalon-ST signaling itself is sufficient to determine the cycles that a component should and should not be enabled. Avalon-ST compliant components may have a clock enable input for their internal logic, but they must take care to ensure that the timing of the interface control signals still adheres to the protocol.

## 6.3. Avalon-ST Interface Properties

Table 6–2 lists the properties that characterize an Avalon-ST interface.

Name	Default Value	Legal Values	Description
<code>dataBitsPerSymbol</code>	8	1–512	Defines the number of bits per symbol. For example, byte-oriented interfaces have 8-bit symbols. This value is not restricted to be a power of 2.
<code>readyLatency</code>	0	0–8	Defines the relationship between assertion/deassertion of the <code>ready</code> signal, and cycles which are considered to be <code>ready</code> for data transfer, separately for each interface.

**Table 6–2. Avalon-ST Interface Properties (Part 2 of 2)**

Name	Default Value	Legal Values	Description
maxChannel	0	0–255	The maximum number of channels that a data interface can support.
errorDescriptor	0	list of strings	A list of words that describe the error associated with each bit of the <code>error</code> signal. The length of the list must be the same as the number of bits in the error signal, and the first word in the list applies to the highest order bit. For example, “ <code>crc, overflow</code> ” means that <code>bit[1]</code> of error indicates a CRC error, and <code>bit[0]</code> indicates an overflow error.

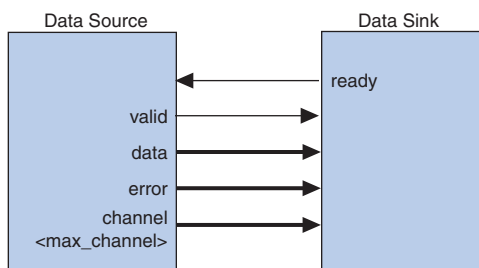
## 6.4. Typical Data Transfers

This section defines the transfer of data from a source interface to a sink interface. In all cases, the data source and the data sink must comply with the specification. It is not the responsibility of the data sink to detect source protocol errors.

### 6.4.1. Signal Details

This section describes the basic Avalon-ST protocol that all data transfers must follow. It also highlights the flexibility you have in choosing Avalon-ST signals to meet the needs of a particular component and makes recommendations concerning the signals that should be used.

**Figure 6.2. typical Avalon-ST Interface Signals**



- `ready` – On interfaces supporting backpressure, `ready` is asserted by the sink to mark *ready cycles*, cycles where transfers may take place. Data interfaces that support backpressure must define the `readyLatency` parameter so that if `ready` is asserted on cycle  $N$ , cycle  $(N + \text{readyLatency})$  is considered a ready cycle.

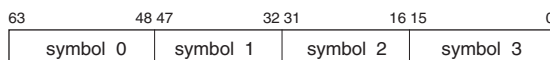
- `valid` – The `valid` signal qualifies valid data on any cycle where data is being transferred from the source to the sink. The `valid` signal is required by all interfaces. On each active cycle the data signal and other source to sink signals are sampled by the sink.
- `data` – The data signal typically carries the bulk of the information being transferred from the source to the sink, and consists of one or more symbols being transferred on every clock cycle. The `dataBitsPerSymbol` parameter defines how the data signal is divided into symbols.
- `error` – Errors are signaled with the `error` signal, where each bit in error corresponds to a possible error condition. A value of 0 on any cycle indicates the data on that cycle is error-free. The action that a component takes when an error is detected is not defined by this specification.
- `channel` – The optional `channel` signal is driven by the source to indicate the channel to which the data belongs. The meaning of `channel` for a given interface depends on the application: some applications use `channel` as a port number indication, while other applications use `channel` as a page number or timeslot indication. When the `channel` signal is used, all of the data transferred in each active cycle belongs to the same `channel`. The source may change to a different channel on successive active cycles.

An interface that uses the `channel` signal must define the `maxChannel` parameter to indicate the maximum channel number. If the number of channels that the interface supports varies while the component is operating, `maxChannel` is the maximum channel number that the interface can support.

### 6.4.2. Data Layout

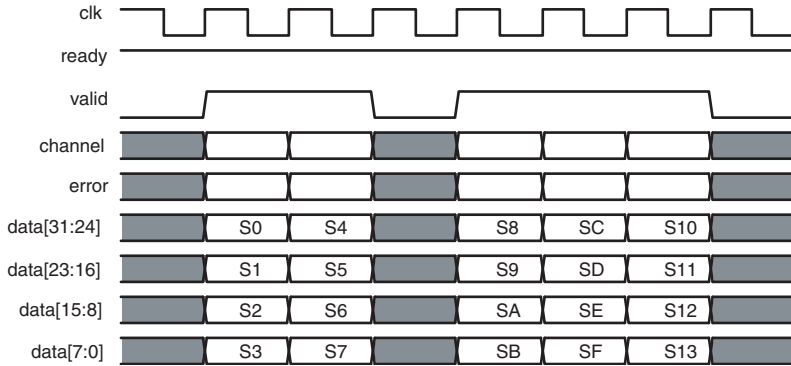
Symbol ordering is big endian, such that the high-order symbol is composed of the most significant bits. [Figure 6.3](#) shows a 64-bit data signal with `symbolsPerBeat=4` and `dataBitsPerSymbol=16`.

**Figure 6.3. Data Symbols**



The timing diagram in [Figure 6.4](#), provides a 32-bit example where  $\text{dataBitsPerSymbol}=8$   $\text{symbolsPerBeat}=4$ . In this figure, D0 is the most significant symbol and  $\text{data}[31]$  is the most significant bit of the most significant symbol.

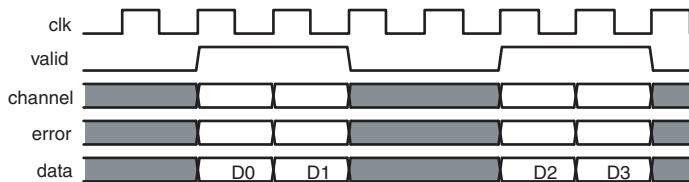
**Figure 6.4. Big Endian Layout of Data**



## 6.5. Data Transfer without Backpressure

The data transfer without backpressure is the most basic of Avalon-ST data transfers. On any given clock cycle, the source interface drives the data and the optional `channel` and `error` signals, and asserts `valid`. The sink interface samples these signals on the rising edge of the reference clock if `valid` is asserted. [Figure 6.5](#) shows an example of data transfer without backpressure.

**Figure 6.5. Data Transfer without Backpressure**



## 6.6.Data Transfer with Backpressure

The sink indicates to the source that it is ready for an active cycle by asserting the `ready` signal for a single clock cycle. Cycles during which the sink is ready for data are called *ready cycles*. During a ready cycle, the source may assert `valid` and provide data to the sink. If it has no data to send, it deasserts `valid` and can drive data to any value.

Each interface that supports backpressure defines the `readyLatency` parameter to indicate the number of cycles from the time that `ready` is asserted until valid data can be driven. If an interface defines `readyLatency` to be 0, then the cycle during which `ready` is asserted is the ready cycle. If `readyLatency` has a nonzero value, the interface considers cycle  $(N + \text{readyLatency})$  to be a ready cycle if `ready` is asserted on cycle  $N$ . Any interface that includes the `ready` signal and defines the `readyLatency` parameter supports backpressure.

When `readyLatency=0`, data is transferred only when `ready` and `valid` are asserted on the same cycle. In this mode of operation, the source does not receive the sink's `ready` signal before it begins sending valid data. The source provides the data and asserts `valid` whenever it can and waits for the sink to capture the data and assert `ready`. The sink only captures input data from the source when `ready` and `valid` are both asserted.

Figure 6.6 illustrates a transfer with backpressure and `readyLatency=0`. The source provides data and asserts `valid` on cycle 1, even though the sink is not ready. The source waits until cycle two, when the sink does assert `ready`, before moving onto the next data cycle. In cycle 3, the source drives data on the same cycle and the sink is ready to receive it; the transfer happens immediately. In cycle 4, the sink asserts `ready`, but the source does not drive valid data.

**Figure 6.6. Transfer with Backpressure, `readyLatency=0`**

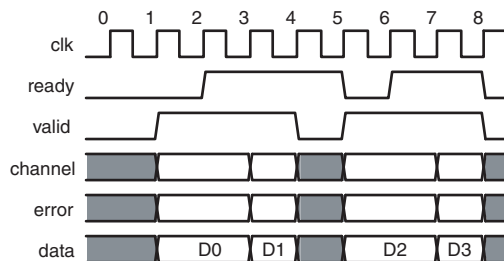
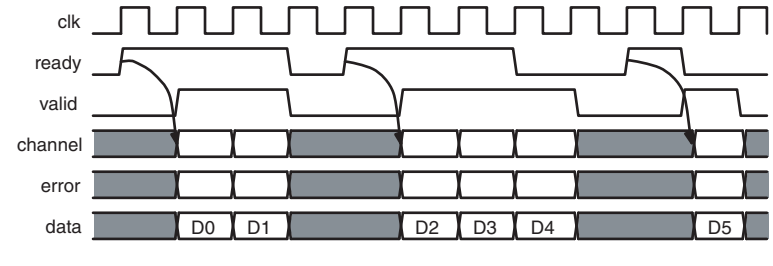


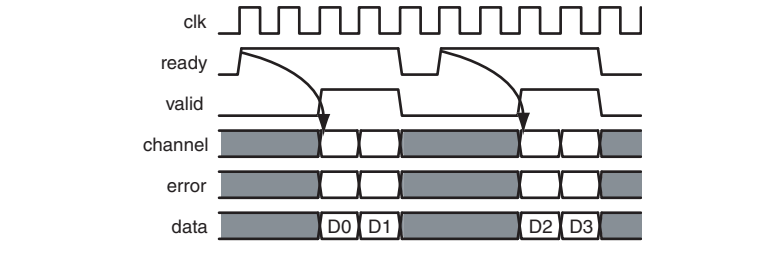
Figure 6.7 and Figure 6.8 show data transfers with `readyLatency=1` and `readyLatency=2`, respectively. In both these cases, `ready` is asserted before the ready cycle, and the source responds 1 or 2 cycles later

by providing data and asserting `valid`. When `readyLatency` is not 0, the source must deassert `valid` on non-ready cycles. The sink captures data on any cycle where `valid` is asserted, regardless of the value of `ready` on that cycle.

**Figure 6.7. Transfer with Backpressure, `readyLatency=1`**

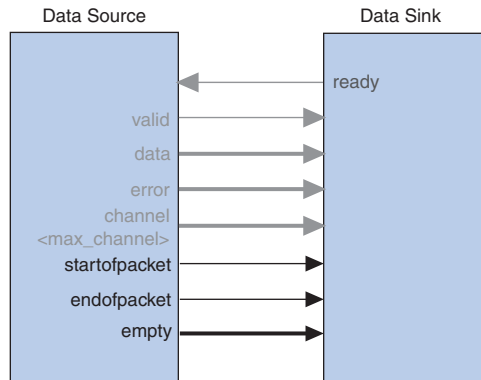


**Figure 6.8. Transfer with Backpressure, `readyLatency=2`**



## 6.7. Packet Data Transfers

The packet transfer property adds support for transferring packets from a source interface to a sink interface. Three additional signals are defined to implement the packet transfer.

**Figure 6.9. Avalon-ST Packet Interface Signals**

### 6.7.1. Signal Details

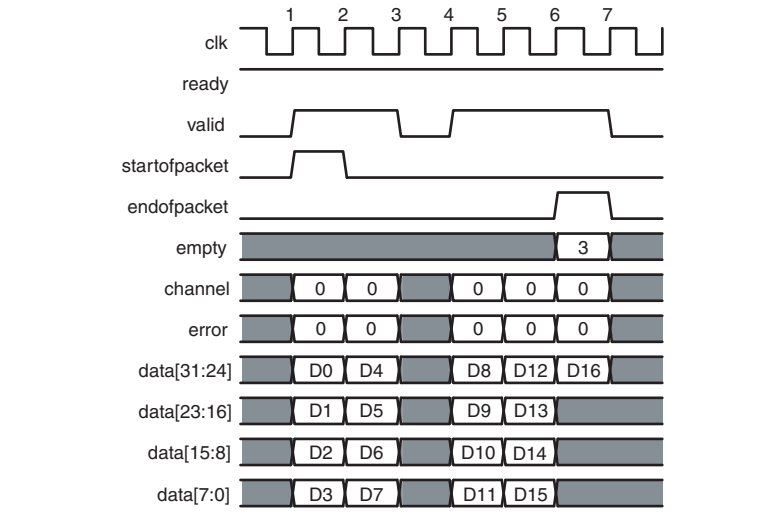
- `startofpacket` – The `startofpacket` signal is required by all interfaces supporting packet transfers and marks the active cycle containing the start of the packet. This signal is only interpreted when `valid` is asserted.
- `endofpacket` – The `endofpacket` signal is required by all interfaces supporting packet transfer and marks the active cycle containing the end of the packet. This signal is only interpreted when `valid` is asserted.
- `empty` – The optional `empty` signal indicates the number of symbols that are empty during the cycles that mark the end of a packet. The sink only checks the value of the `empty` signal during active cycles that have `endofpacket` asserted. The empty symbols are always the last symbols in `data`, those carried by the low-order bits. The `empty` signal is required on all packet interfaces whose `data` signal carries more than one symbol of data and have a variable length packet format. The size of the `empty` signal in bits is  $\log_2(\text{symbols per cycle})$ .

### 6.7.2. Protocol Details

Packet data transfer follows the same protocol as the typical data transfer described in “[Typical Data Transfers](#)” on page 6–6, with the addition of the `startofpacket`, `endofpacket`, and `empty`.

Figure 6.10 illustrates the transfer of a 17-byte packet from a source interface to a sink interface, where `readyLatency=0`. Data transfer occurs on cycles 1, 2, 4, 5, and 6, when both `ready` and `valid` are asserted. During cycle 1, `startofpacket` is asserted, and the first 4 bytes of packet are transferred. During cycle 6, `endofpacket` is asserted, and `empty` has a value of 3, indicating that this is the end of the packet and that 3 of the 4 symbols are empty. In cycle 6, the high-order byte, `data[31:24]` drives valid data because Avalon-ST is big-endian.

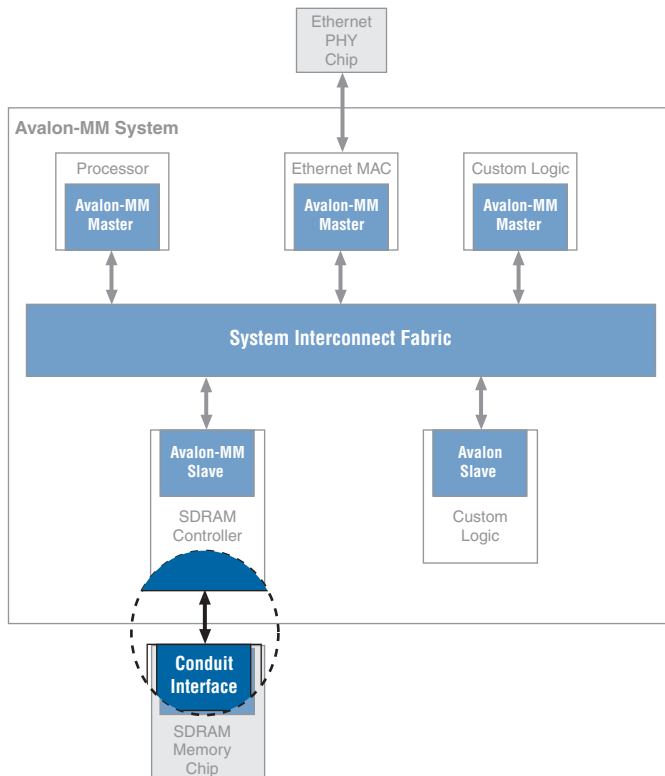
**Figure 6.10. Packet Transfer**





Conduit interfaces are used to group together an arbitrary collection of signals to be exported to the outside of an SOPC Builder system. A conduit interface can consist of both input and output signals. Directions, such as source and sink for Avalon-ST interfaces or in and out for Avalon-MM masters and slaves, do not apply to conduit interfaces. A module can have multiple conduit interfaces to provide a logical grouping of the signals being exported. [Figure 7.1](#) illustrates this interface.

**Figure 7.1. Focus on the Conduit Interface**



In this figure, signals that interface to the SDRAM, such as address, data and control signals, form a conduit interface and would have the signal type `export`.

### 7.1. Properties

There are no properties for conduit interfaces.

### 7.2. Signals

[Table 7.1](#) lists the conduit signal types.

<b>Signal Type</b>	<b>Width</b>	<b>Direction</b>	<b>Required</b>	<b>Description</b>
<code>export</code>	$n$	In, out or bidirectional	Yes	A conduit interface consists of one or more signals of arbitrary width, that are inputs or output, of type <code>export</code> . All of these signals are exported out the top level of the SOPC Builder system.



## Document Revision History

Table Info.1 shows the revision history for this document.

<i>Table Info.1. Document Revision History</i>		
Date and Document Version	Changes Made	Summary of Changes
October 2008, v1.1	<ul style="list-style-type: none"><li>• Clarified burst behavior in “Burst Transfers” on page 3–27. A master can issue a new read burst before the data for the previous burst has been returned.</li><li>• Added section discussing native addressing and the fact that it is deprecated.</li><li>• Improved description of big-endian data layout.</li><li>• Clarified behavior of <code>waitrequest</code> signal for Avalon-MM slaves. Avalon-MM masters may initiate transactions when <code>waitrequest</code> is asserted.</li></ul>	Clarification for some Avalon-MM descriptions.
March 2008, v1.0	Combined previous <i>Avalon Memory-Mapped Interface Specification</i> with <i>Avalon Streaming Interface Specification</i> . Added separate chapters for clocks, tristate slaves, interrupts, and conduits.	—

## How to Contact Altera

For the most up-to-date information about Altera products, refer to the table.








Information Type	Contact Method	Contact (1)
Technical support	Website	<a href="http://www.altera.com/support/">www.altera.com/support/</a>
Technical training	Website	<a href="http://www.altera.com/training/">www.altera.com/training/</a>
	Email	<a href="mailto:Ccustrain@altera.com">Ccustrain@altera.com</a>
Altera literature services	Email	<a href="mailto:lliterature@altera.com">lliterature@altera.com</a>
Non-technical support (General)	Email	<a href="mailto:nacomp@altera.com">nacomp@altera.com</a>
(Software Licensing)	Email	<a href="mailto:aauthorization@altera.com">aauthorization@altera.com</a>

**Note to table:**

(1) You can also contact your local Altera sales office or sales representative.

## Typographic Conventions

This document uses the typographic conventions shown below.

Visual Cue	Meaning
<b>Bold Type with Initial Capital Letters</b>	Command names, dialog box titles, checkbox options, and dialog box options are shown in bold, initial capital letters. Example: <b>Save As</b> dialog box.
<b>bold type</b>	External timing parameters, directory names, project names, disk drive names, filenames, filename extensions, and software utility names are shown in bold type. Examples: <b>f<sub>MAX</sub></b> , <b>lqdesigns</b> directory, <b>d:</b> drive, <b>chiptrip.gdf</b> file.
<i>Italic Type with Initial Capital Letters</i>	Document titles are shown in italic type with initial capital letters. Example: <i>AN 75: High-Speed Board Design</i> .
<i>Italic type</i>	Internal timing parameters and variables are shown in italic type. Examples: <i>t<sub>PIA</sub></i> , <i>n + 1</i> .  Variable names are enclosed in angle brackets (< >) and shown in italic type. Example: <file name>, <project name>.pdf file.
Initial Capital Letters	Keyboard keys and menu names are shown with initial capital letters. Examples: Delete key, the Options menu.
“Subheading Title”	References to sections within a document and titles of on-line help topics are shown in quotation marks. Example: “Typographic Conventions.”
Courier type	Signal and port names are shown in lowercase Courier type. Examples: data1, tdi, input. Active-low signals are denoted by suffix n, e.g., resetn.  Anything that must be typed exactly as it appears is shown in Courier type. For example: c:\qdesigns\tutorial\chiptrip.gdf. Also, sections of an actual file, such as a Report File, references to parts of files (e.g., the VHDL keyword BEGIN), as well as logic function names (e.g., TRI) are shown in Courier.
1., 2., 3., and a., b., c., etc.	Numbered steps are used in a list of items when the sequence of the items is important, such as the steps listed in a procedure.
	Bullets are used in a list of items when the sequence of the items is not important.
	The checkmark indicates a procedure that consists of one step only.
	The hand points to information that requires special attention.
	The caution indicates required information that needs special consideration and understanding and should be read prior to starting or continuing with the procedure or process.
	The warning indicates information that should be read prior to starting or continuing the procedure or processes
	The angled arrow indicates you should press the Enter key.
	The feet direct you to more information on a particular topic.