

CLEAR LOGIC

# CL8000 PACKAGING GUIDE

## Introduction

This document will provide you with package outlines for all available CL8000 packages. It also provides information regarding lead finish and package mass.

## Package Outlines

### LC84: 84-Pin Plastic Leaded Chip Carrier (PLCC)

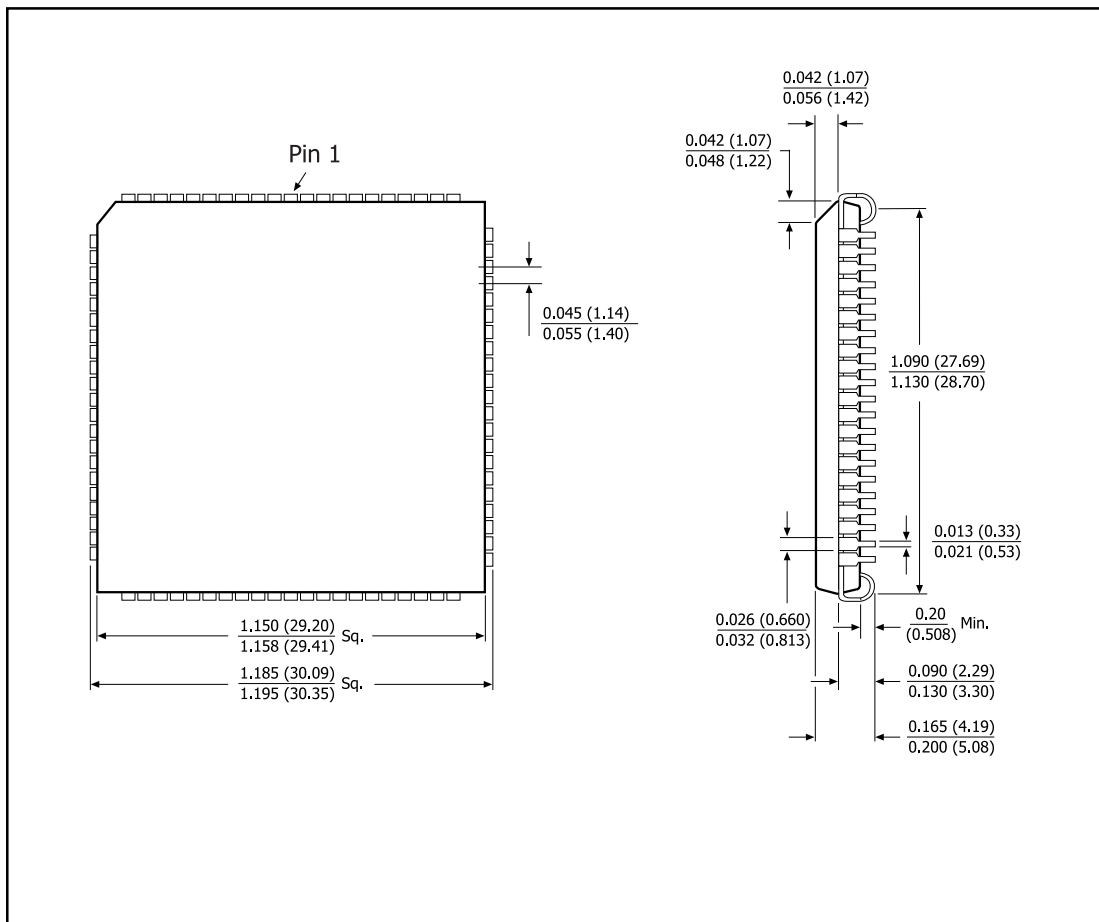

**TC100: 100-Pin Plastic Thin Quad Flat Pack (TQFP)**

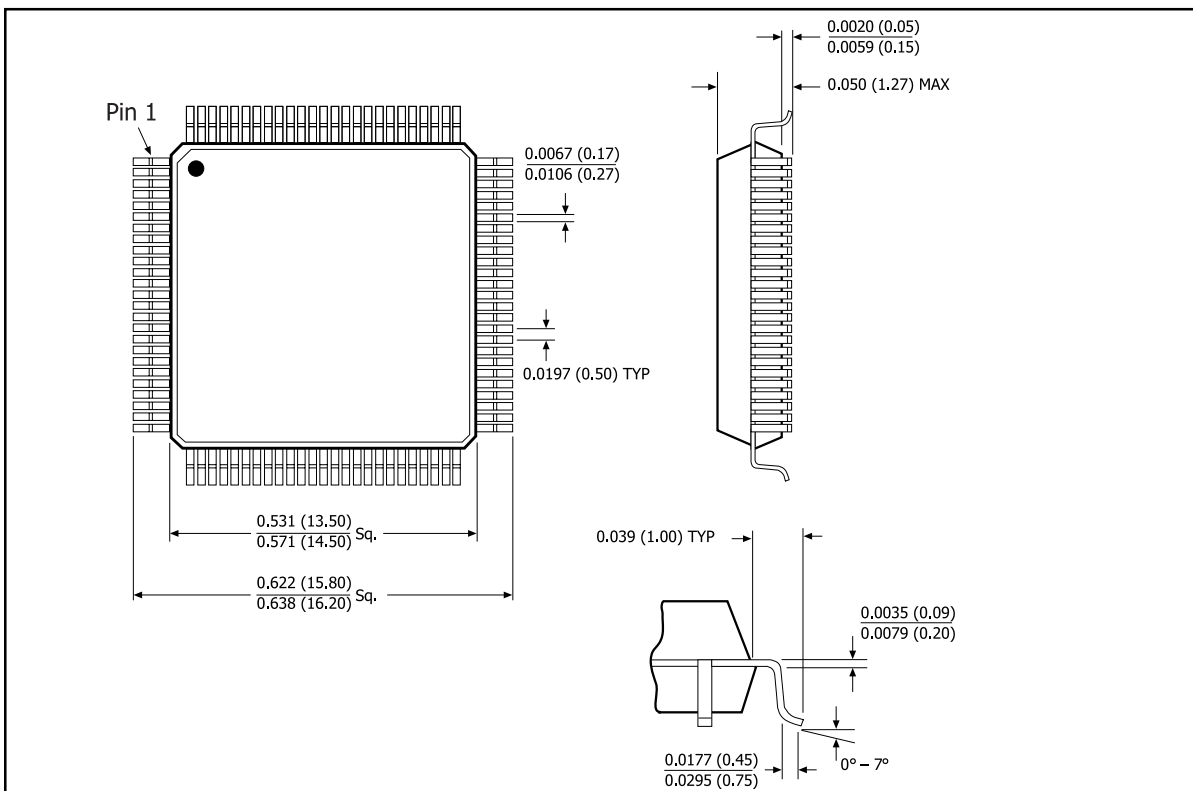

**TC144: 144-Pin Plastic Thin Quad Flat Pack (TQFP)**

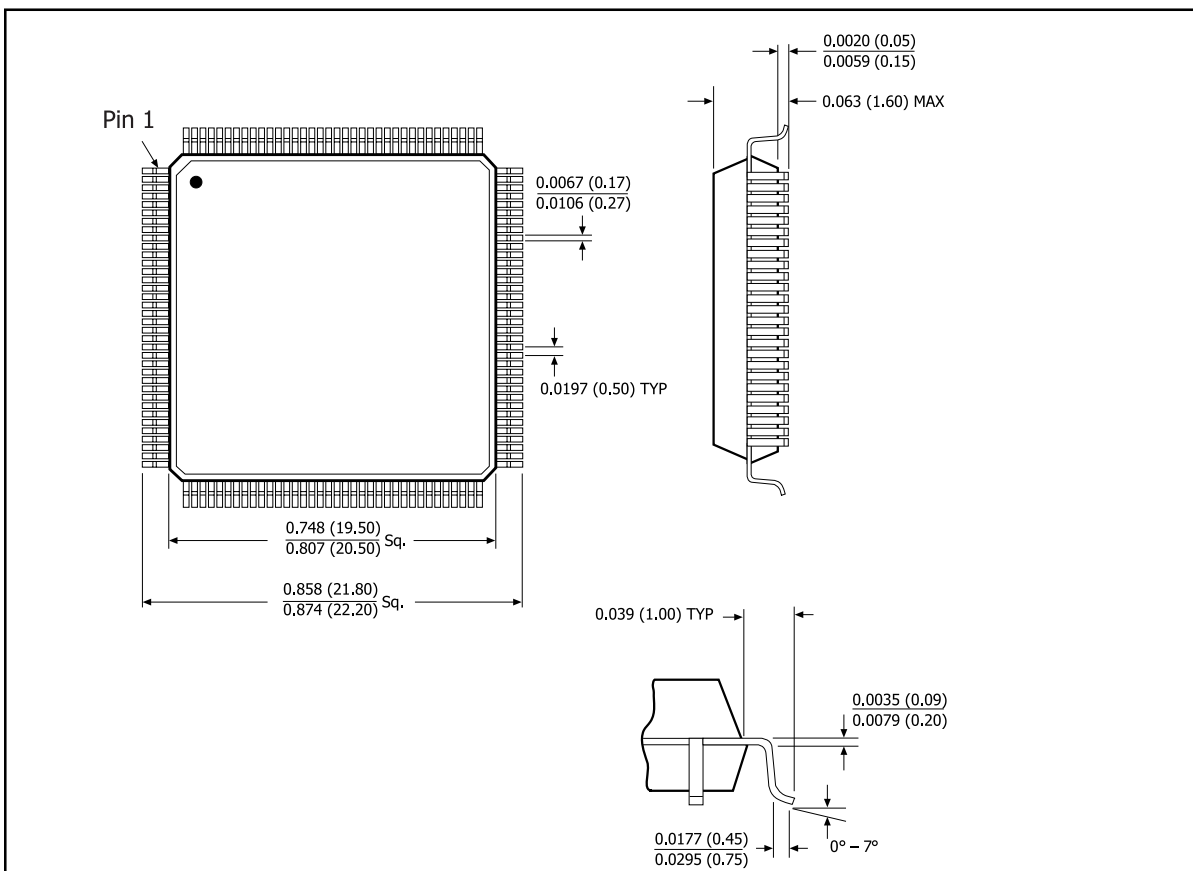

**QC160: 160-Pin Plastic Quad Flat Pack (PQFP)**

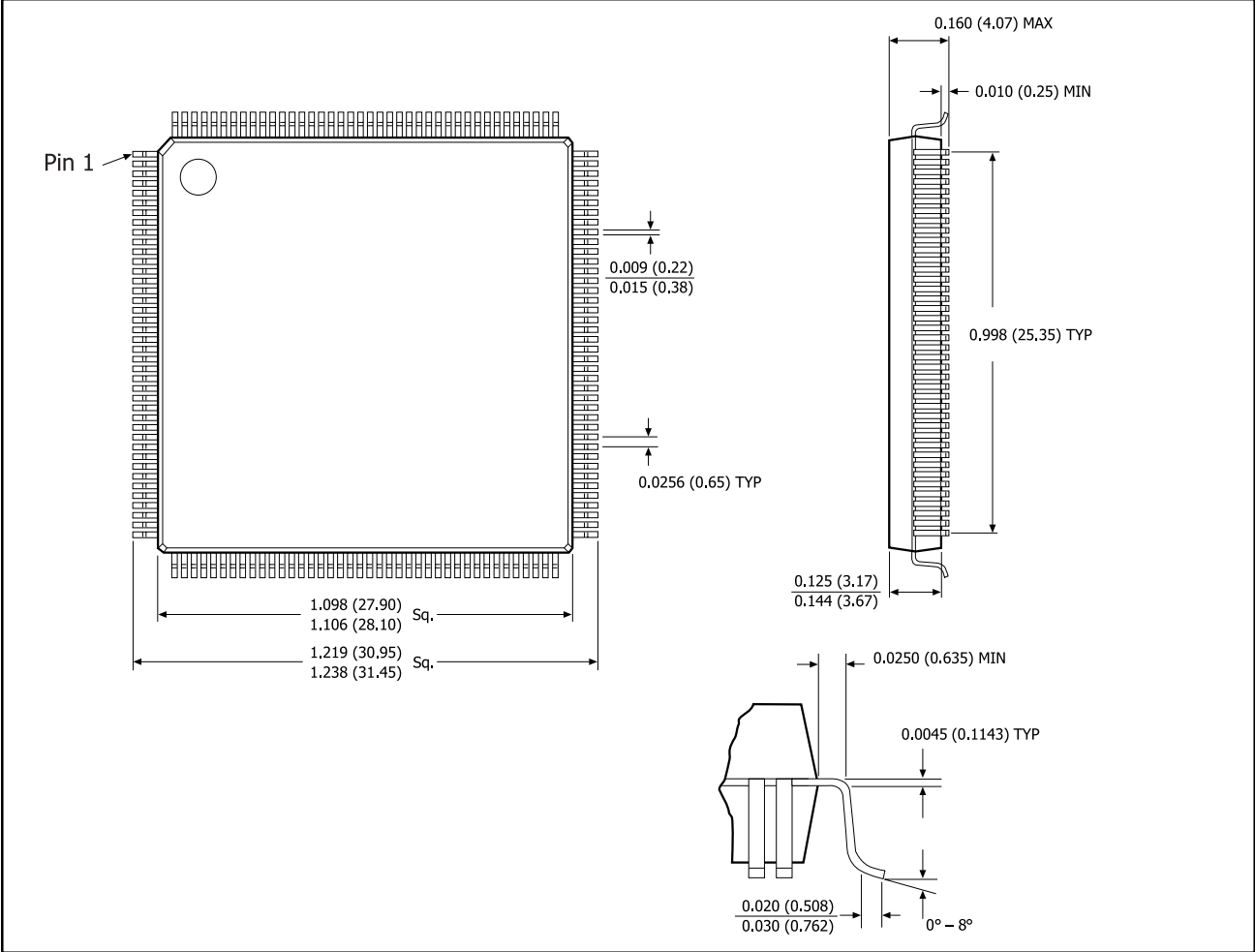

### QC208: 208-Pin Plastic Quad Flat Pack (PQFP)

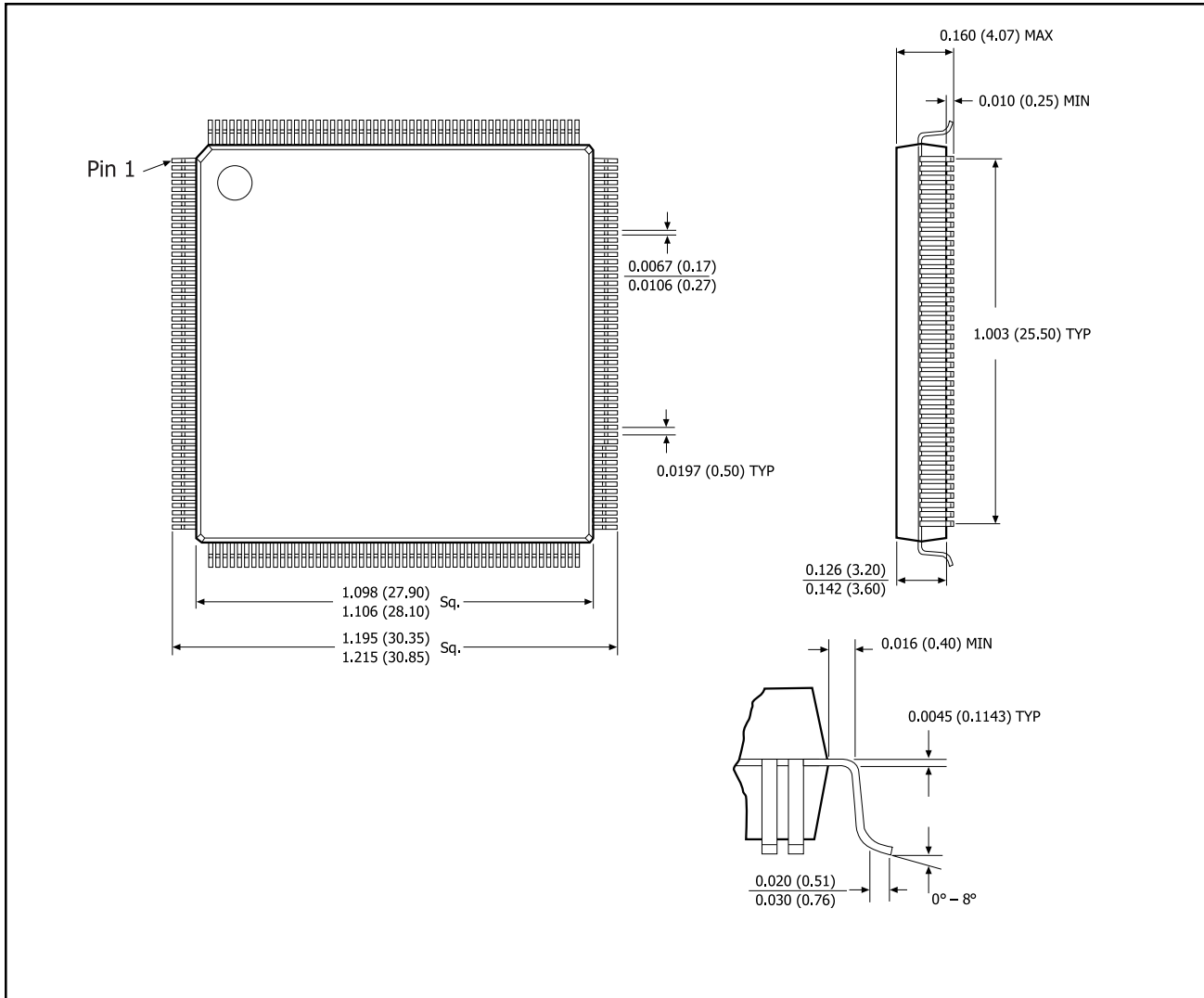

**BC225: 225-Pin Plastic Ball Grid Array (BGA)**

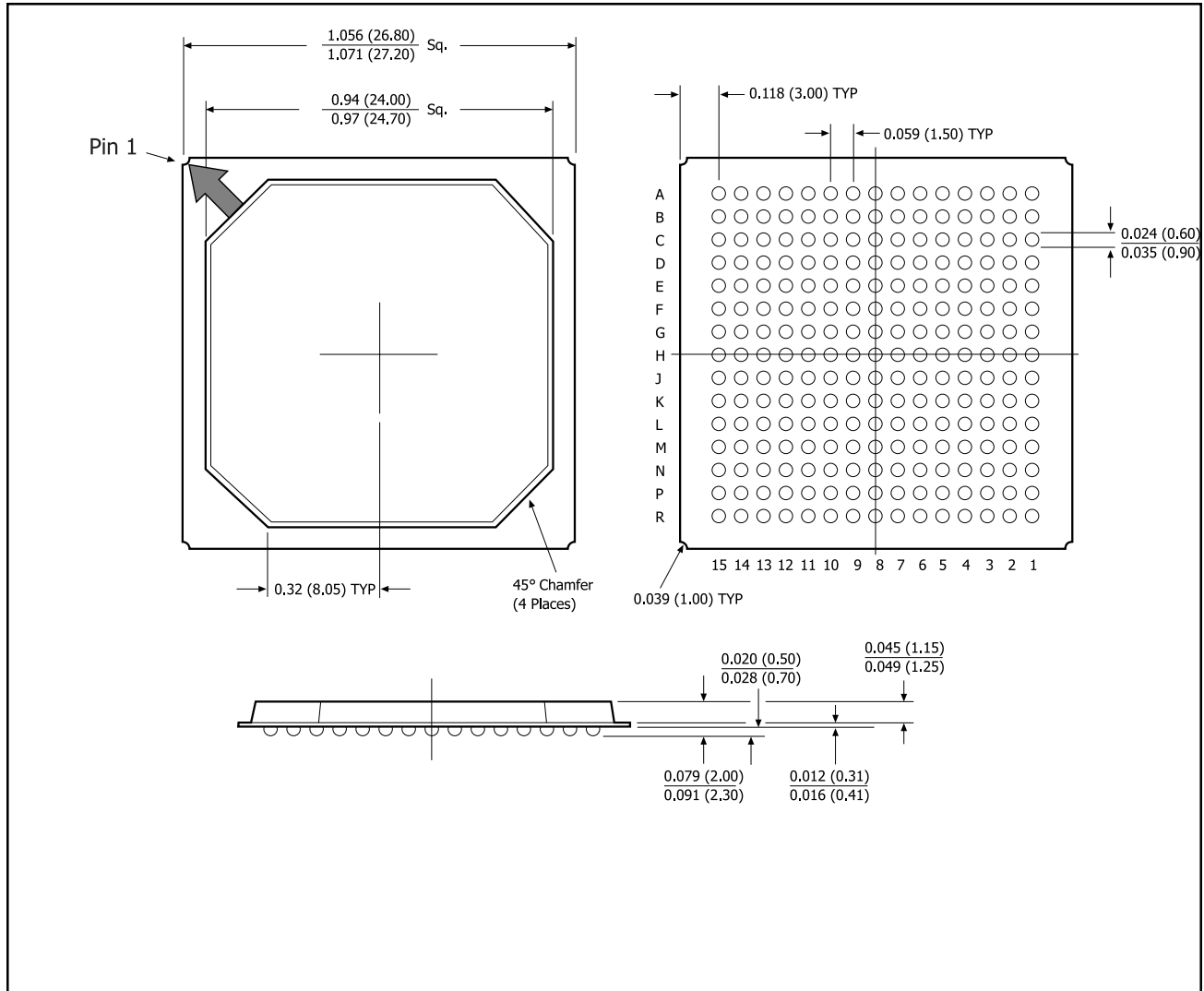

**QC240: 240-Pin Plastic Quad Flat Pack (PQFP)**

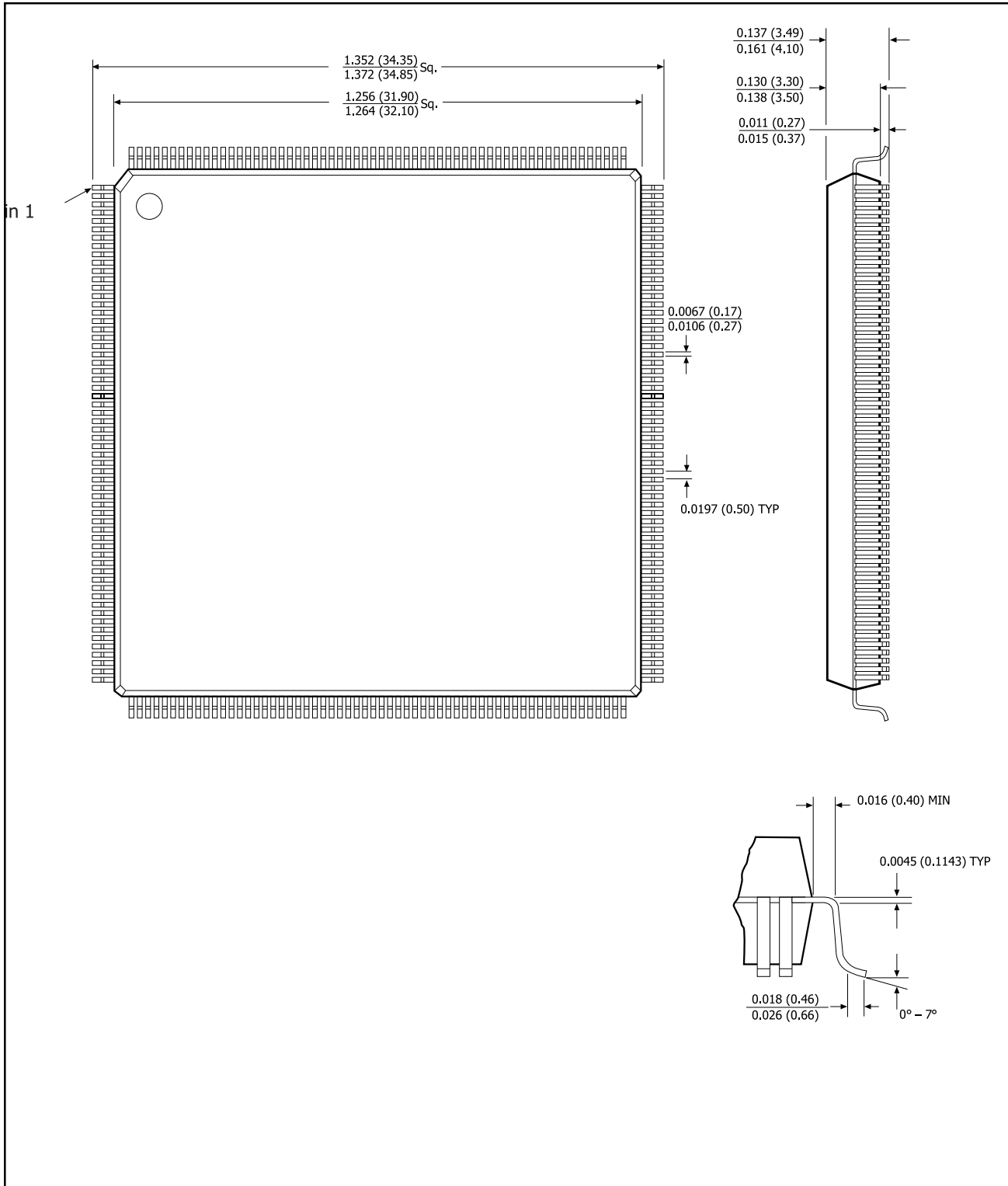

**QC304: 304-Pin Plastic Quad Flat Pack (PQFP)**

