

SEALEVEL[®]

SYSTEMS INCORPORATED

SeaLINK+485I[™]

USER MANUAL



Part # 2104

Sealevel Systems, Inc
155 Technology Place
P.O. Box 830
Liberty, SC 29657 USA

Phone: (864) 843-4343
FAX: (864) 843-3067
www.sealevel.com

Contents

INTRODUCTION	1
OVERVIEW	1
WHAT'S INCLUDED.....	1
INSTALLATION.....	2
OPERATING SYSTEM INSTALLATION	2
SYSTEM INSTALLATION	2
CONFIGURATION.....	6
ELECTRICAL INTERFACE SELECTION	6
SWITCH EXAMPLES	7
TECHNICAL DESCRIPTION	8
FEATURES	8
CONNECTOR PIN ASSIGNMENTS (DB25 MALE)	8
SPECIFICATIONS.....	9
ENVIRONMENTAL SPECIFICATIONS.....	9
MANUFACTURING.....	9
POWER CONSUMPTION	9
MEAN TIME BETWEEN FAILURES (MTBF)	9
PHYSICAL DIMENSIONS.....	9
APPENDIX A - TROUBLESHOOTING	10
APPENDIX B - HOW TO GET ASSISTANCE	11
APPENDIX C - ELECTRICAL INTERFACE.....	12
RS-422	12
RS-485	12
APPENDIX D - GROUND LOOP PHENOMENON	13
WHAT IS GROUND LOOP?.....	13
CABLING RECOMMENDATIONS	13
APPENDIX E - ASYNCHRONOUS COMMUNICATIONS.....	14
APPENDIX F - SILK-SCREEN	15

APPENDIX G - COMPLIANCE NOTICES 16
 FEDERAL COMMUNICATIONS COMMISSION STATEMENT16
 EMC DIRECTIVE STATEMENT16
WARRANTY 17

Figures

Figure 1- RS-422, 4 Wire RS-485 (Default)..... 7
Figure 2 - RS-485, 2 Wire with Echo 7
Figure 3 - RS-485, 2 Wire No Echo 7
Figure 4 – SeaLINK+485I cabling example 13
Figure 5 - Asynchronous Communications Bit Diagram..... 14

© 2002c Sealevel Systems, Incorporated. All rights reserved.

Introduction

Overview

The Sealevel Systems **SeaLINK+485I** equips the PC with 1 isolated USB to RS-422/485 Asynchronous serial port providing a versatile interface for common RS-422/485 needs. The **SeaLINK+485I** connects through the PC's external USB port, so it does not require opening the computer case. Resources such as IRQ's and I/O addresses are also not utilized. It does require a system that supports USB in hardware and operating system.

What's Included

The **SeaLINK+485I** is shipped with the following items. If any of these items is missing or damaged, contact the supplier.

- **SeaLINK+485I** Isolated USB to RS-422/485 Serial I/O Adapter
- USB Cable Part Number CA179 for Connecting to Upstream Host/Hub
- Sealevel Software

Installation

Operating System Installation

Please note that you should install the software before the hardware.

Choose **Install Software** at the beginning of the CD and select the **Serial I/O** software drivers and install **SeaCOM**.

System Installation

The screen captures below are taken from a Windows 98 installation. Your particular operating system may differ slightly from what is shown based on your version of windows.

The **SeaLINK+485I** can be connected to any Upstream Type “A” port either at the PC host or an Upstream Hub. The **SeaLINK+485I** is hot-pluggable, meaning there is no need to power down your computer prior to installation. The **SeaLINK+485I** has an onboard 8 position dip switch that is used to configure the interface. Prior to connecting the **SeaLINK+485I**, be sure to configure this dip switch for your specific application. Please see the Configuration section for more information. The **SeaLINK+485I** is defaulted to RS-422 mode so changes are only required if you will be using the product in an RS-485 application.

1. After installing the software connect **SeaLINK+485I** to an Upstream Host or Hub.



This indicates that the system has recognized the new device and will now proceed to locate a driver.



Since you have already installed the software by running “Setup”, simply click “Next” to proceed. The drivers that were installed during setup will automatically be used to configure the adapter for use.



Windows has now located a driver and installed the software. After the driver has been located click “Finish. You should see one more “New Hardware Found”, indicating the actual port being created. If you view your systems Device Manager at this point, you should have a new “COM” port in the Port(COM & LPT) Device Class. It should look similar to the screen shot on the following page.

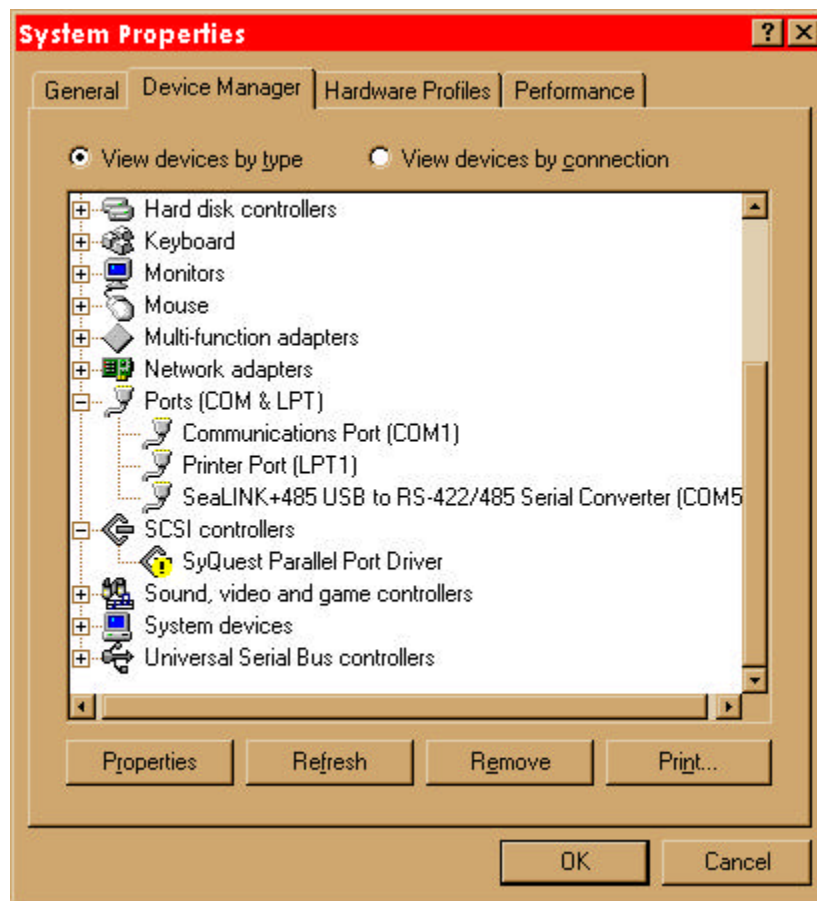

You can access your new COM: port by using the assigned COM: identifier shown above. In this case, it is COM5: but this assignment will vary from system to system. At this point, the hardware is recognized. To verify operation use Sealevel Systems supplied WinSSD diagnostic utility. WinSSD can be found in the Start menu under Programs, SeaCOM group.

Configuration

Electrical Interface Selection

The port on the **SeaLINK+485I** has the ability to be used in both half and full duplex RS-422/485 applications. This is selectable through DIP-switch SW1. The chart below describes each of the switch position's function. Please refer to the following page for switch setting examples. Switch SW1, in the "ON" position, either enables, adds or connects, based on the function of the switch position listed below. Switch SW1, position OFF, disables, removes or disconnects .

SW1	Function
1	RS-485 Two Wire Auto Enable/Disable
2	Echo Enable/Disable
3	Adds or removes the 120 ohm termination
4	Adds or removes the 1K ohm pull-up resistor in the RS-422/RS-485 receiver circuit (Receive data only)
5	Adds or removes the 1K ohm pull-down resistor in the RS-422/RS-485 receiver circuit (Receive data only)
6	Connects the TX+ to RX+ for RS-485 two wire operation
7	Connects the TX- to RX- for RS-485 two wire operation
8	Not Used

Switch Examples

Please use the following examples to configure your adapter.



Figure 1- RS-422, 4 Wire RS-485 (Default)

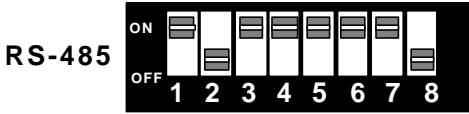

Figure 2 - RS-485, 2 Wire with Echo

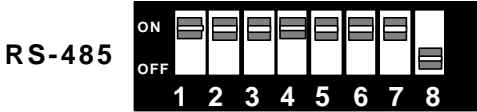

Figure 3 - RS-485, 2 Wire No Echo

Technical Description

The **SeaLINK+485I** utilizes a USB UART. This chip features programmable baud rate, data format, 128 byte Dual Port TX Buffer, and 384 byte Dual Port RX Buffer. The RS-422/485 transceiver supports data rates up to 921.6K baud.

Features

- Hot-Pluggable device
- Does not require opening the case
- No system resources are required (i.e. I/O ports or IRQ's)
- LED status indicators for “USB Enabled”, “TD”, and “RD”

Connector Pin Assignments (DB25 Male)

The **SeaLINK+485I** complies with the EIA-530 pin out with the following signals supported

Signal		Name	Pin #	Mode
GND		Ground	7	
RDB	RX+	Receive Positive	16	Input
RDA	RX-	Receive Negative	3	Input
TDB	TX+	Transmit Positive	14	Output
TDA	TX-	Transmit Negative	2	Output

Technical Note: The modem control signals are biased as follows : RTS is connected to CTS, DTR is connected to DCD and DSR, and RI is tied inactive.

Specifications

Environmental Specifications

Specification	Operating	Storage
Temperature Range	0° to 50° C (32° to 122° F)	-20° to 70° C (-4° to 158° F)
Humidity Range	10 to 90% R.H. Non-Condensing	10 to 90% R.H. Non-Condensing

Manufacturing

- All Sealevel Systems Printed Circuit boards are built to UL 94V0 rating and are 100% electrically tested. These printed circuit boards are solder mask over bare copper or solder mask over tin nickel.

Power Consumption

Supply line	+5 VDC		
Rating	100 mA		

Mean Time Between Failures (MTBF)

Greater than 150,000 hours. (Calculated)

Physical Dimensions

Package Length	3.8 inches	(9.66 cm)
Package Width	2.3 inches	(5.84 cm)
Package Height	1.0 inches	(2.54 cm)

Appendix A - Troubleshooting

Serial Utility test software is supplied with the Sealevel Systems adapter and should be used in the troubleshooting procedures. Using this software and following these steps, most common problems can be eliminated.

1. If your adapter isn't working, first check to make sure that USB support is enabled in the System BIOS and it is functioning properly in the operating system. This can be done by using either the Windows 98/ME or Windows 2000 Device Manager.
2. Ensure that the Sealevel Systems software has been installed on the machine so that the necessary files are in place to complete the installation.
3. When the **SeaLINK+485I** is configured properly, the USB Enabled LED (EN) will be lit. This should allow you to use Sealevel's WinSSD utility and the supplied loopback plug to check communications. The supplied loopback plug connects TD to RD. If you decide to test the Modem Control Signals, a full pin loopback plug will be required. Details on loopback plugs are included on WinSSD. Contact Sealevel Systems if you need further assistance
4. When testing the **SeaLINK+485I** in loopback mode, you should see both the TD and RD LED's flashing as well as seeing echoed data on the screen. The loopback test first transmits a HEX pattern, 55AA, and then an ASCII string of data. If this test passes, then the **SeaLINK+485I** is ready for use in your application.
5. Please note that if the card is configured for 2 wire RS-485 with no echo a loopback test is not possible. The receiver in this case will be turned off and the test will fail. If you plan on using this device in two wire mode test the adapter in RS-422 mode first. Then configure the adapter for your application.

Appendix B - How To Get Assistance

Please refer to
Appendix A - Troubleshooting prior to calling Technical Support.

1. Read this manual thoroughly before attempting to install the adapter in your system.
2. When calling for technical assistance, please have your user manual and current adapter settings ready. If possible, please have the adapter connected in a computer ready to run diagnostic tests.
3. Please visit www.sealevel.com for the latest software updates and manuals.
4. Technical support is available Monday through Friday from 8:00 a.m. to 5:00 p.m. Eastern time. Technical support can be reached at (864) 843-4343.

RETURN AUTHORIZATION MUST BE OBTAINED FROM SEALEVEL SYSTEMS BEFORE RETURNED MERCHANDISE WILL BE ACCEPTED. AUTHORIZATION CAN BE OBTAINED BY CALLING SEALEVEL SYSTEMS AND REQUESTING A RETURN MERCHANDISE AUTHORIZATION (RMA) NUMBER.

Appendix C - Electrical Interface

RS-422

The RS-422 specification defines the electrical characteristics of balanced voltage digital interface circuits. RS-422 is a differential interface that defines voltage levels and driver/receiver electrical specifications. On a differential interface, logic levels are defined by the difference in voltage between a pair of outputs or inputs. In contrast, a single ended interface, for example RS-232, defines the logic levels as the difference in voltage between a single signal and a common ground connection. Differential interfaces are typically more immune to noise or voltage spikes that may occur on the communication lines. Differential interfaces also have greater drive capabilities that allow for longer cable lengths. RS-422 is rated up to 10 Megabits per second and can have cabling 4000 feet long. RS-422 also defines driver and receiver electrical characteristics that will allow 1 driver and up to 32 receivers on the line at once. RS-422 signal levels range from 0 to +5 volts. RS-422 does not define a physical connector.

RS-485

RS-485 is backwardly compatible with RS-422; however, it is optimized for partyline or multi-drop applications. The output of the RS-422/485 driver is capable of being **Active** (enabled) or **Tri-State** (disabled). This capability allows multiple ports to be connected in a multi-drop bus and selectively polled. RS-485 allows cable lengths up to 4000 feet and data rates up to 10 Megabits per second. The signal levels for RS-485 are the same as those defined by RS-422. RS-485 has electrical characteristics that allow for 32 drivers and 32 receivers to be connected to one line. This interface is ideal for multi-drop or network environments. RS-485 tri-state driver (not dual-state) will allow the electrical presence of the driver to be removed from the line. Only one driver may be active at a time and the other driver(s) must be tri-stated. RS-485 can be cabled in two ways, two wire and four wire mode. Two wire mode does not allow for full duplex communication and requires that data be transferred in only one direction at a time. For half-duplex operation, the two transmit pins should be connected to the two receive pins (Tx+ to Rx+ and Tx- to Rx-). Four wire mode allows full duplex data transfers. RS-485 does not define a connector pin-out or a set of modem control signals. RS-485 does not define a physical connector.

Appendix D - Ground Loop Phenomenon

What is Ground Loop?

Ground loop Phenomenon occurs when two (or more) pieces of equipment are connected together with a common ground and a different ground potential exists at each location. This current can cause the connected equipment to experience noise that in turn causes data transmission errors. In extreme cases ground current can cause equipment malfunction or even destruction.

Cabling Recommendations

When connecting the **SeaLINK+485I** in an RS-485 network, care should be taken that both ends of the network are not isolated from ground (see Figure 4). This “floating” ground condition could cause capacitive or inductive coupling of voltages that will cause a break down in the DC to DC converter circuit or in the opto-isolator circuit. This condition will cause data errors and possibly destruction of the receiver circuit.

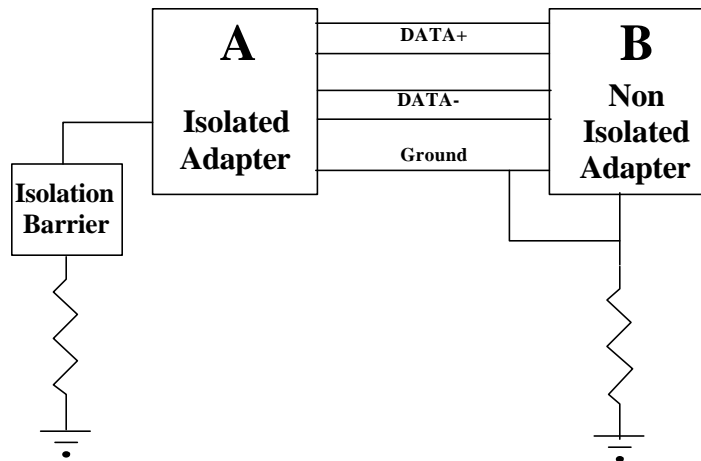

Figure 4 – **SeaLINK+485I** cabling example

Appendix E - Asynchronous Communications

Serial data communications implies that individual bits of a character are transmitted consecutively to a receiver that assembles the bits back into a character. Data rate, error checking, handshaking, and character framing (start/stop bits) are pre-defined and must correspond at both the transmitting and receiving ends.

Asynchronous communications is the standard means of serial data communication for PC compatibles and PS/2 computers. The original PC was equipped with a communication or COM: port that was designed around an 8250 Universal Asynchronous Receiver Transmitter (UART). This device allows asynchronous serial data to be transferred through a simple and straightforward programming interface. Character boundaries for asynchronous communications are defined by a starting bit followed by a pre-defined number of data bits (5, 6, 7, or 8). The end of the character is defined by the transmission of a pre-defined number of stop bits (usually 1, 1.5 or 2). An extra bit used for error detection is often appended before the stop bits.

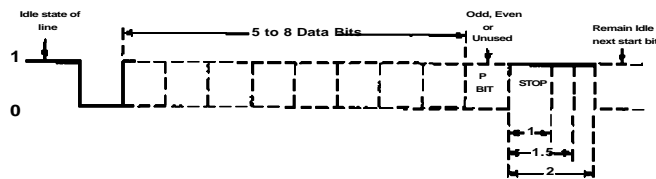

Figure 5 - Asynchronous Communications Bit Diagram

This special bit is called the parity bit. Parity is a simple method of determining if a data bit has been lost or corrupted during transmission. There are several methods for implementing a parity check to guard against data corruption. Common methods are called (E)ven Parity or (O)dd Parity. Sometimes parity is not used to detect errors on the data stream. This is referred to as (N)o parity. Because each bit in asynchronous communications is sent consecutively, it is easy to generalize asynchronous communications by stating that each character is wrapped (framed) by pre-defined bits to mark the beginning and end of the serial transmission of the character. The data rate and communication parameters for asynchronous communications have to be the same at both the transmitting and receiving ends. The communication parameters are baud rate, parity, number of data bits per character, and stop bits (i.e. 9600,N,8,1).

Appendix F - Silk-Screen



Appendix G - Compliance Notices

Federal Communications Commission Statement

FCC - This equipment has been tested and found to comply with the limits for Class A digital device, pursuant to Part 15 of the FCC Rules. These limits are designed to provide reasonable protection against harmful interference when the equipment is operated in a commercial environment. This equipment generates, uses, and can radiate radio frequency energy and, if not installed and used in accordance with the instruction manual, may cause harmful interference to radio communications. Operation of this equipment in a residential area is likely to cause harmful interference. In such case the user will be required to correct the interference at his own expense.

EMC Directive Statement



Products bearing the CE Label fulfill the requirements of the EMC directive (89/336/EEC) and of the low-voltage directive (73/23/EEC) issued by the European Commission.

To obey these directives, the following European standards must be met:

EN55022 Class B - 'Limits and methods of measurement of radio interference characteristics of information technology equipment'

EN55024 - 'Information technology equipment Immunity characteristics Limits and methods of measurement.'

EN60950 (IEC950) - 'Safety of information technology equipment, including electrical business equipment'

Always use cabling provided with this product if possible. If no cable is provided or if an alternate cable is required, use high quality shielded cabling to maintain compliance with EMC directives.

Warranty



Sealevel Systems, Inc. provides a lifetime warranty for this product. Should this product fail to be in good working order at any time during this period, Sealevel Systems will, at its option, replace or repair it at no additional charge except as set forth in the following terms. This warranty does not apply to products damaged by misuse, modifications, accident or disaster.

Sealevel Systems assumes no liability for any damages, lost profits, lost savings or any other incidental or consequential damage resulting from the use, misuse of, or inability to use this product. Sealevel Systems will not be liable for any claim made by any other related party.

RETURN AUTHORIZATION MUST BE OBTAINED FROM SEALEVEL SYSTEMS BEFORE RETURNED MERCHANDISE WILL BE ACCEPTED. AUTHORIZATION CAN BE OBTAINED BY CALLING SEALEVEL SYSTEMS AND REQUESTING A RETURN MERCHANDISE AUTHORIZATION (RMA) NUMBER.

Sealevel Systems, Incorporated
155 Technology Place
P.O. Box 830
Liberty, SC 29657 USA
(864) 843-4343 FAX: (864) 843-3067
www.sealevel.com
email: support@sealevel.com

Technical Support is available from 8 a.m. to 5 p.m. Eastern time.
Monday - Friday

Trademarks

Sealevel Systems, Incorporated acknowledges that all trademarks referenced in this manual are the service mark, trademark, or registered trademark of the respective company.

SeaLINK+485I is a trademark of Sealevel Systems, Incorporated.