



SeaPORT REL-16™

USER MANUAL



Part # 8208

Sealevel Systems, Inc
155 Technology Place
P.O. Box 830
Littleton, CO 80120 USA

Phone: (864) 843-4343
FAX: (864) 843-3067
www.sealevel.com

Contents

INTRODUCTION.....	1
OVERVIEW	1
WHAT'S INCLUDED.....	1
INSTALLATION.....	1
TECHNICAL DESCRIPTION	2
FEATURES	2
REED RELAYS	2
RELAY SPECIFICATIONS	2
APPLICATION PROGRAMMERS INTERFACE (API)	3
SERIAL STRING.....	3
RELATIVE ADDRESSING VS. ABSOLUTE ADDRESSING.....	3
<i>Side Panel View Port A</i>	5
<i>Side Panel View Port B</i>	5
3 RD PARTY SOFTWARE SUPPORT	6
SPECIFICATIONS	7
ENVIRONMENTAL SPECIFICATIONS.....	7
POWER CONSUMPTION	7
MEAN TIME BETWEEN FAILURES (MTBF)	7
APPENDIX A - TROUBLESHOOTING.....	8
APPENDIX B - HOW TO GET ASSISTANCE.....	9
APPENDIX C - SILK-SCREEN	10
APPENDIX D - COMPLIANCE NOTICES.....	11
FEDERAL COMMUNICATIONS COMMISSION STATEMENT	11
EMC DIRECTIVE STATEMENT.....	11
WARRANTY	12
© 2002c Sealevel Systems, Incorporated. All rights reserved.	
Figure 1:Addressing Tables.....	4
Figure 2:Pin Assignments.....	5
Figure 3:Box Layout View	5

Introduction

Overview

The **SeaPORT REL-16** provides 16 reed relays that can latch power, data or other electronic signals for control applications. The **SEAPORT REL-16** is USB 1.1 compliant.

What's Included

The **SeaPORT REL-16** is shipped with the following items. If any of these items is missing or damaged, contact the supplier.

- **SeaPORT REL-16** Adapter
- Sealevel Software
- USB A to B Cable, Part number CA179

Installation

Be sure to install the software before the hardware.

Choose **Install Software** at the beginning of the CD. Select the **Digital I/O** software drivers and install **SeaIO** prior to installing hardware. After installing the software, connect the USB cable to the **SeaPORT REL-16** with the other end connecting to any Upstream Type "A" USB port. The port can be either the PC host or an upstream hub. When connected and properly enumerated, the device's enable LED will come on. The device will not open properly until it has been enumerated by the operating system.

Technical Description

The **SeaPORT REL-16** provides two parallel reed relay output ports. The ports are organized as ports A, and B. The **SeaPORT REL-16** is a line-powered device requiring a USB port capable of sourcing 500 mA.

Features

- 16 SPST relays
- Removal Terminal block connectors
- Highly reliable 10 VA DIP reed relays utilized
- Multiple adapters can be used in same computer

Reed Relays

Reed relays provide very high quality, long life, low power, dry contact switch closures. Reed relays are not suited for high current applications, or inductive loads. The relays are normally open, and close when energized.

Relay Specifications

- Contact Power Ratings: 10-Watts Maximum
- Contact Voltage Maximum: 100 Volts DC or AC Maximum
- Contact Current Maximum: .5 Amps DC or AC RMS
- Contact Resistance, Initial: .15 Ohms
- Rated Life:
 - Low Load: 200 Million Closures
 - Maximum Load: 100 Million Closures
- Contact Speed:
 - Operate: .5 mS
 - Release: .5 mS
 - Bounce: .5 mS
- Maximum Operating Speed: 600 Hertz

Application Programmers Interface (API)

Most modern operating systems do not allow direct hardware access. The **SeaI/O** driver and API have been included to provide control over the hardware in Windows. The purpose of this section of the manual is to help the customer with the mapping of the API to the actual I/O and relays for the **SeaPORT REL-16** specifically. Complete documentation of the API can be found in the **SeaI/O** help file.

Serial String

Each device has an eight digit alphanumeric serial string stored in non-volatile memory. On the Windows platforms, this number is used to give each unit a separate identity. This identity allows the device to be moved to any USB port or hub port on your computer while retaining its device number. If a device becomes damaged and is replaced the new device should be given the same serial string as the device it is replacing. This string is stored in a EEPROM along with other critical information. This EEPROM is read during enumeration. The device should not be unplugged during its enumeration due to remote possibility that the data in the EEPROM could be corrupted if power is removed during a read/write cycle to the EEPROM. Enumerator is complete when the LED is lit.

The control panel utility provides the capability to read or modify this string. However, **setting the same string for two units will cause the second unit to fail enumeration, and make it invisible to the operating system.** Should this occur, unplug one unit and set the serial string for the other unit to a different value.

Relative Addressing vs. Absolute Addressing

The **SeaI/O** API makes a distinction between “absolute” and “relative” addressing modes. In absolute addressing mode, the Port argument to the API function acts as a simple byte offset from the base I/O address of the device. For instance, Port #0 refers to the I/O 0; Port #1 refers to the I/O address 1.

Relative addressing mode, on the other hand, refers to input and output ports in a logical fashion. With a Port argument of 0 and an API function meant to output data, the first (0th) output port on the device will be utilized. Likewise, with a Port argument of 0 and an API function designed to input data, the first (0th) input port of the device will be utilized.

In all addressing modes, port numbers are zero-indexed; that is, the first port is port #0, the second port is #1, the third #2, and so on.

Tables: API Port/bit reference numbers for Absolute and Relative Addressing

R = Read
 W = Write
 R/W = Read or Write

Figure 1: Addressing Tables

Port	API Port # Absolute Address (function)	API Port # Relative Address (function)	Port Type
A	0 (R/W)	0 (W)	Reed Relay output port
B	1 (R/W)	1 (W)	Reed Relay output port

API Bit # Absolute Address (function)	API Bit # Relative Address (function)	Port Bit
0 (R/W)	0 (W)	A0 - Output
1 (R/W)	1 (W)	A1 - Output
2 (R/W)	2 (W)	A2 - Output
3 (R/W)	3 (W)	A3 - Output
4 (R/W)	4 (W)	A4 - Output
5 (R/W)	5 (W)	A5 - Output
6 (R/W)	6 (W)	A6 - Output
7 (R/W)	7 (W)	A7 - Output
8 (R/W)	0 (W)	B0 – Output
9 (R/W)	1 (W)	B1 – Output
10 (R/W)	2 (W)	B2 – Output
11 (R/W)	3 (W)	B3 – Output
12 (R/W)	4 (W)	B4 – Output
13 (R/W)	5 (W)	B5 – Output
14 (R/W)	6 (W)	B6 – Output
15 (R/W)	7 (W)	B7 – Output

Pin Assignments (Removable Terminal Block)

Port A Bit	Port A Terminals
0	0,1
1	2,3
2	4,5
3	6,7
4	8,9
5	10,11
6	12,13
7	14,15

Port B Bit	Port B Terminals
0	0,1
1	2,3
2	4,5
3	6,7
4	8,9
5	10,11
6	12,13
7	14,15

Figure 2: Pin Assignments

Side Panel View Port A

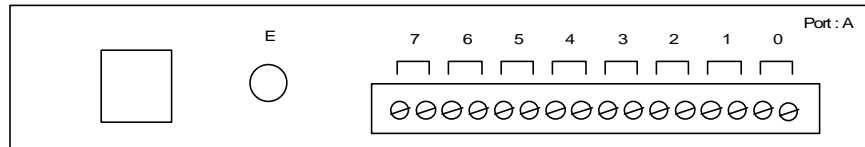

Side Panel View Port B

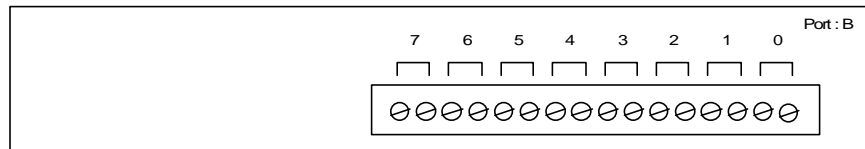

Figure 3: Enclosure Layout View

3rd Party Software Support

Third party software support for many HMI/MMI and other process control software is included on the product installation CD. For the most up to date information on third party software support, please visit <http://www.sealevel.com/3rdpartysw.htm>.



Specifications

Environmental Specifications

Specification	Operating	Storage
Temperature Range	0° to 70° C (32° to 158° F)	-20° to 70° C (-4° to 158° F)
Humidity Range	10 to 90% R.H. Non-Condensing	10 to 90% R.H. Non-Condensing

Power Consumption

Supply line	+5 VDC
Rating	500 mA

Mean Time Between Failures (MTBF)

Greater than 150,000 hours. (Calculated)

Appendix A - Troubleshooting

Following these simple steps can eliminate most common problems.

Install software **first**. After installing the software then proceed to adding the hardware. This places the required installation files in the correct locations.

1. Read this manual thoroughly before attempting to install the adapter in your system.
2. Use Device Manager under Windows to verify proper installation.
3. Use the SeaIO control panel applet for card identification and configuration.

If these steps do not solve your problem, please call Sealevel Systems' Technical Support, (864) 843-4343. Our technical support is free and available from 8:00AM-5PM Eastern Time Monday through Friday.

Appendix B - How To Get Assistance

1. Begin by reading through the Trouble Shooting Guide in Appendix A. If assistance is still needed please see below.
2. When calling for technical assistance, please have your user manual and current adapter settings. If possible, please have the adapter installed in a computer ready to run diagnostics.
3. Sealevel Systems provides an FAQ section on its web site. Please refer to this for many commonly asked questions. This section can be found at <http://www.sealevel.com/faq.htm>.
4. Visit Sealevel's website at www.sealevel.com for the latest software updates and newest manuals.
5. Technical support is available Monday to Friday from 8:00 a.m. to 5:00 p.m. eastern time. Technical support can be reached at (864) 843-4343.

RETURN AUTHORIZATION MUST BE OBTAINED FROM SEALEVEL SYSTEMS BEFORE RETURNED MERCHANDISE WILL BE ACCEPTED. AUTHORIZATION CAN BE OBTAINED BY CALLING SEALEVEL SYSTEMS AND REQUESTING A RETURN MERCHANDISE AUTHORIZATION (RMA) NUMBER.

Appendix C - Silk-Screen

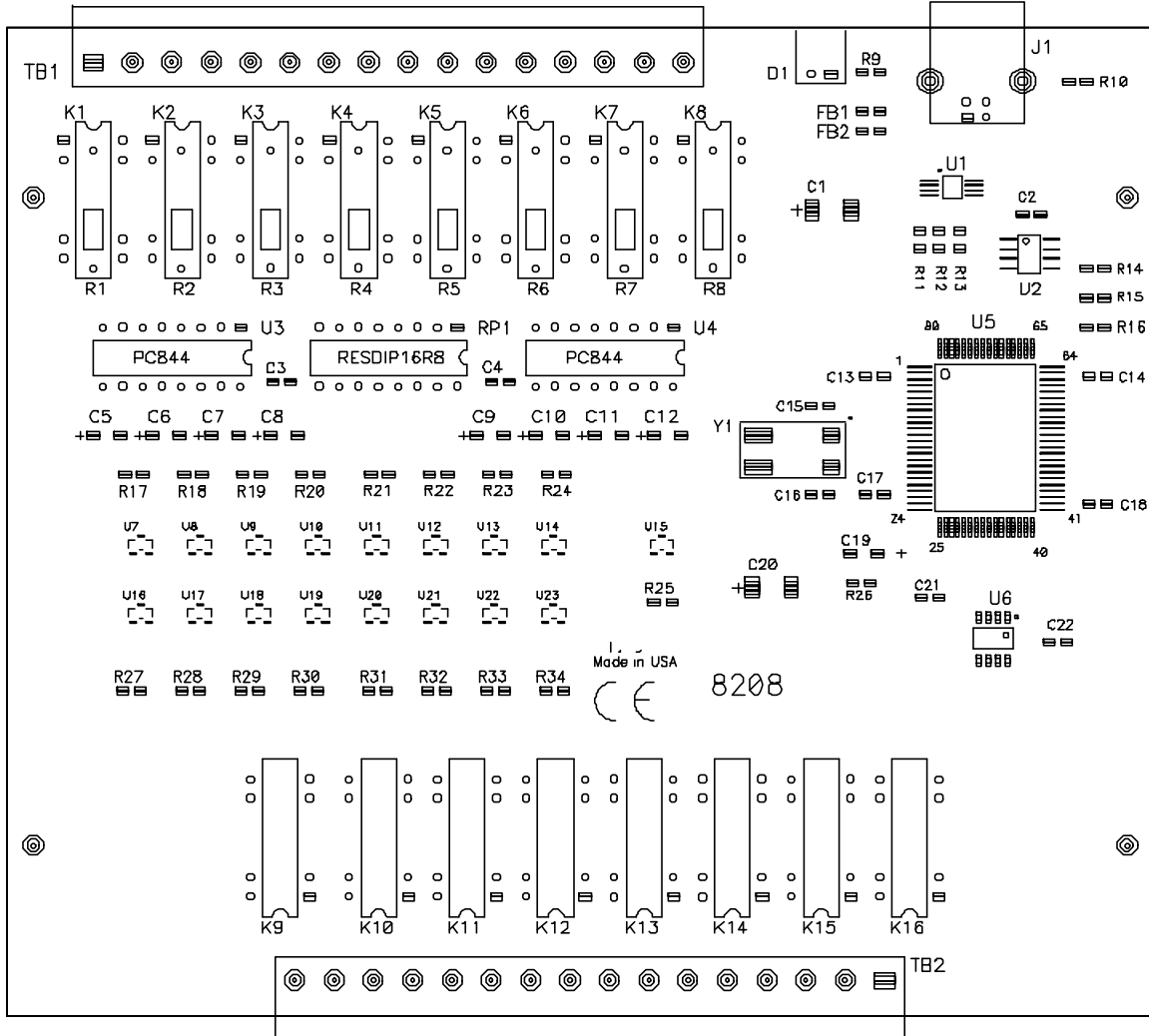

Appendix D - Compliance Notices

Federal Communications Commission Statement

FCC - This equipment has been tested and found to comply with the limits for Class A digital device, pursuant to Part 15 of the FCC Rules. These limits are designed to provide reasonable protection against harmful interference when the equipment is operated in a commercial environment. This equipment generates, uses, and can radiate radio frequency energy and, if not installed and used in accordance with the instruction manual, may cause harmful interference to radio communications. Operation of this equipment in a residential area is likely to cause harmful interference. In such case the user will be required to correct the interference at his own expense.

EMC Directive Statement



Products bearing the CE Label fulfill the requirements of the EMC directive (89/336/EEC) and of the low-voltage directive (73/23/EEC) issued by the European Commission.

To obey these directives, the following European standards must be met:

- **EN55022 Class A** - "Limits and methods of measurement of radio interference characteristics of information technology equipment"
- **EN55024** - 'Information technology equipment Immunity characteristics Limits and methods of measurement'
- **EN60950 (IEC950)** - "Safety of information technology equipment, including electrical business equipment"

Warning

This is a Class A Product. In a domestic environment this product may cause radio interference in which case the user may be required to take adequate measures.

Always use cabling provided with this product if possible. If no cable is provided or if an alternate cable is required, use high quality shielded cabling to maintain compliance with FCC/EMC directives.

Warranty



Sealevel Systems, Inc. provides a limited lifetime warranty. Should this product fail to be in good working order at any time during this period, Sealevel Systems will, at its option, replace or repair it at no additional charge except as set forth in the following terms. This warranty does not apply to products damaged by misuse, modifications, accident or disaster.

Sealevel Systems assumes no liability for any damages, lost profits, lost savings or any other incidental or consequential damage resulting from the use, misuse of, or inability to use this product. Sealevel Systems will not be liable for any claim made by any other related party.

RETURN AUTHORIZATION MUST BE OBTAINED FROM SEALEVEL SYSTEMS BEFORE RETURNED MERCHANDISE WILL BE ACCEPTED. AUTHORIZATION CAN BE OBTAINED BY CALLING SEALEVEL SYSTEMS AND REQUESTING A RETURN MERCHANDISE AUTHORIZATION (RMA) NUMBER.

Sealevel Systems, Incorporated
155 Technology Place
P.O. Box 830
Liberty, SC 29657 USA
(864) 843-4343 FAX:(864) 843-3067
www.sealevel.com
email: support@sealevel.com

Technical Support is available from 8 a.m. to 5 p.m. Eastern time.
Monday - Friday

Trademarks

Sealevel Systems, Incorporated acknowledges that all trademarks referenced in this manual are the service mark, trademark, or registered trademark of the respective company.

SeaPORT REL-16 is a trademark of Sealevel Systems, Incorporated.