



SeaPORT DIO-16TM

USER MANUAL



Part # 8209

Sealevel Systems, Inc
155 Technology Place
P.O. Box 830
Farmingdale, SC 20657 USA

Phone: (864) 843-4343
FAX: (864) 843-3067
www.sealevel.com

Contents

INTRODUCTION.....	1
OVERVIEW	1
WHAT'S INCLUDED.....	1
INSTALLATION.....	1
TECHNICAL DESCRIPTION	2
<i>Digital Inputs</i>	2
DIGITAL INPUT PORT	2
TURN-ON VOLTAGE.....	3
REED RELAY OUTPUT PORT.....	4
RELAY SPECIFICATIONS	4
PROGRAMMING.....	5
APPLICATION PROGRAMMERS INTERFACE (API)	5
SERIAL STRING.....	5
RELATIVE ADDRESSING VS. ABSOLUTE ADDRESSING.....	5
3 RD PARTY SOFTWARE SUPPORT.....	6
PIN ASSIGNMENTS (REMOVABLE TERMINAL BLOCK).....	8
<i>Side Panel View Port A</i>	8
<i>Side Panel View Port B</i>	8
SPECIFICATIONS	9
ENVIRONMENTAL SPECIFICATIONS.....	9
POWER CONSUMPTION.....	9
MEAN TIME BETWEEN FAILURES (MTBF)	9
APPENDIX A - TROUBLESHOOTING.....	10
APPENDIX B - HOW TO GET ASSISTANCE.....	11
APPENDIX C - SILK-SCREEN	12

APPENDIX D - COMPLIANCE NOTICES..... 13
FEDERAL COMMUNICATIONS COMMISSION STATEMENT..... 13
EMC DIRECTIVE STATEMENT 13
WARRANTY 14

© 2002c Sealevel Systems, Incorporated. All rights reserved.

Figures

Figure 1:Input Wiring2
Figure 2:Addressing Tables.....7
Figure 3:Pin Out8
Figure 4:Enclosure Layout View.....8

Introduction

Overview

The **SeaPORT DIO-16** provides 16 optically isolated inputs to allow monitoring of off board switch closures, relays or any other general purpose monitoring needs.

What's Included

The **SeaPORT DIO-16** is shipped with the following items. If any of these items is missing or damaged, contact the supplier.

- **SeaPORT DIO-16** Adapter
- Sealevel Software
- USB A to B Cable, Part number CA179

Installation

Be sure to install the software before the hardware.

Choose **Install Software** at the beginning of the CD. Select the **Digital I/O** software drivers and install **SeaIO** prior to installing hardware. After installing the software, connect the USB cable to the **SeaPORT DIO-16** with the other end connecting to any Upstream Type "A" USB port. The port can be either the PC host or an upstream hub. When connected and properly enumerated, the device's enable LED will come on. The device will not open properly until it has been enumerated by the operating system..

Technical Description

The **SeaPORT DIO-16** provides one parallel input port and one parallel reed relay output port. The ports are organized as ports A, and B. The **SeaPORT DIO-16** is a line-powered device requiring a USB port capable of sourcing 500 mA.

Digital Inputs

- Number of inputs: Sixteen.
- Type: Non-polarized, optically isolated from each other and from the computer.
- Voltage Range: 0 to 24V DC or AC

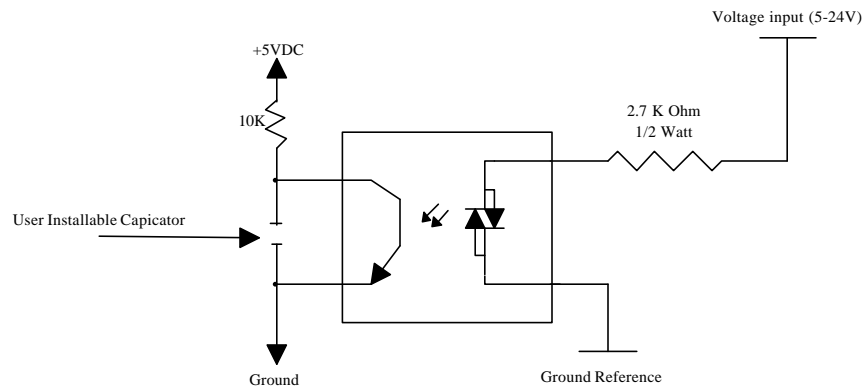

Figure 1: Input Wiring

Digital Input Port

Port A is an 8 bit input port connected to optically isolated input sensors. Each sensor can be used to interface a voltage input and then sense whether the voltage is on or off. Each sensor is isolated (with respect to a common ground) from every other sensor, and also isolated with respect to the host PC ground. This means that signals such as low-level AC line voltage, motor servo voltage, and control relay signals can be 'sensed', or read by the PC, without the risk of damage due to ground loops or ground faults.

Each sensor input pair has a current limiting resistor (2.7K ohm) that is used to limit the input current to the opto-isolator. A current path is required to 'turn-on' the sensor.

The opto-isolator has two 'back-to-back' diodes internally. This allows AC or DC signals to be sensed, regardless of polarity.

Turn-On Voltage

The opto-isolator requires approximately 1 mA to turn on. The maximum input current is 60 mA. Adding additional resistors to the input current limiting resistor can increase the voltage to be sensed. Two things to consider when selecting additional input resistance:

1. Turn on voltage for the circuit to sense.
2. The maximum input voltage. Maximum input voltage is a function of power. The resistor must not allow the opto-isolator to be overdriven. The following formulas apply:

Turn on current: 1 mA
Isolator diode drop: 1.1 V
Resistor power Max: 1/2 W

Turn on Voltage = diode drop + (turn on current) x (resistance)
Maximum voltage = square root of (resistor value * resistor power)

Default Configuration :

Input Turn on Voltage = $1.1V + 0.001A * 2700ohm = 3.8 VDC$

Current Draw = $(Voltage - 1.1) / 2700$

1 mA @ 3.8 VDC

4 mA @ 12 VDC

8.5 mA @ 24 VDC

Absolute Max Voltage (Inputs) =
square root of $(2700ohm * 0.5w) = 36VDC$

The input circuits are not for monitoring 120-volt AC circuits.

Reed Relay Output Port

Reed relays provide very high quality, long life, low power, dry contact switch closures. Reed relays are not suited for high current applications, or inductive loads. The relays are normally open, and close when energized.

Relay Specifications

- Contact Power Ratings: 10-Watts Maximum
- Contact Voltage Maximum: 100 Volts DC or AC Maximum
- Contact Current Maximum: .5 Amps DC or AC RMS
- Contact Resistance, Initial: .15 Ohms
- Rated Life:
 - Low Load: 200 Million Closures
 - Maximum Load: 100 Million Closures
- Contact Speed:
 - Operate: .5 mS
 - Release: .5 mS
 - Bounce: .5 mS
- Maximum Operating Speed: 600 Hertz

Programming

Application Programmers Interface (API)

Most modern operating systems do not allow direct hardware access. The **SeaI/O** driver and API have been included to provide control over the hardware in Windows. The purpose of this section of the manual is to help the customer with the mapping of the API to the actual I/O and relays for the **SeaPORT DIO-16** specifically. Complete documentation of the API can be found in the SeaI/O help file.

Serial String

Each device has an eight digit alphanumeric serial string stored in non-volatile memory. On the Windows platforms, this number is used to give each unit a separate identity. This identity allows the device to be moved to any USB port or hub port on your computer while retaining its device number. If a device becomes damaged and is replaced the new device should be given the same serial string as the device it is replacing. This string is stored in a EEPROM along with other critical information. This EEPROM is read during enumeration. The device should not be unplugged during its enumeration due to remote possibility that the data in the EEPROM could be corrupted if power is removed during a read/write cycle to the EEPROM. Enumeration is complete when the LED is lit.

The control panel utility provides the capability to read or modify this string. However, **setting the same string for two units will cause the second unit to fail enumeration, and make it invisible to the operating system.** Should this occur, unplug one unit and set the serial string for the other unit to a different string.

Relative Addressing vs. Absolute Addressing

The **SeaI/O** API makes a distinction between “absolute” and “relative” addressing modes. In absolute addressing mode, the Port argument to the API function acts as a simple byte offset from the base I/O address of the device. For instance, Port #0 refers to the I/O 0; Port #1 refers to the I/O address 1.

Relative addressing mode, on the other hand, refers to input and output ports in a logical fashion. With a Port argument of 0 and an API function meant to output data, the first (0th) output port on the device will be utilized. Likewise, with a Port argument of 0 and an API function designed to input data, the first (0th) input port of the device will be utilized.

In all addressing modes, port numbers are zero-indexed; that is, the first port is port #0, the second port is #1, the third #2, and so on.

3rd Party Software Support

Third party software support for many HMI/MMI and other process control software is included on the product installation CD. For the most up to date information on third party software support, please visit <http://www.sealevel.com/3rdpartysw.htm>.



Tables: API Port/bit reference numbers for Absolute and Relative Addressing

R = Read
 W = Write
 R/W = Read or Write

Figure 2: Addressing Tables

Port	API Port # Absolute Address (function)	API Port # Relative Address (function)	Port Type
A	0 (R)	0 (R)	Input Port (Opto Input)
B	1 (R/W)	0 (W)	Output Port (Reed Relay)

API Bit # Absolute Address (function)	API Bit # Relative Address (function)	Port Bit
0 (R)	0 (R)	A0 - Input
1 (R)	1 (R)	A1 - Input
2 (R)	2 (R)	A2 - Input
3 (R)	3 (R)	A3 - Input
4 (R)	4 (R)	A4 - Input
5 (R)	5 (R)	A5 - Input
6 (R)	6 (R)	A6 - Input
7 (R)	7 (R)	A7 - Input
8 (R/W)	0 (W)	B0 – Output
9 (R/W)	1 (W)	B1 – Output
10 (R/W)	2 (W)	B2 – Output
11 (R/W)	3 (W)	B3 – Output
12 (R/W)	4 (W)	B4 – Output
13 (R/W)	5 (W)	B5 – Output
14 (R/W)	6 (W)	B6 – Output
15 (R/W)	7 (W)	B7 – Output

Pin Assignments (Removable Terminal Block)

Port A (Input) Bit	Port A Terminals
0	0,1
1	2,3
2	4,5
3	6,7
4	8,9
5	10,11
6	12,13
7	14,15

Port B (Output) Bit	Port B Terminals
0	0,1
1	2,3
2	4,5
3	6,7
4	8,9
5	10,11
6	12,13
7	14,15

Figure 3: Pin Out

Side Panel View Port A

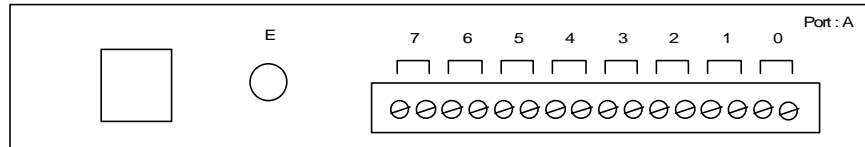

Side Panel View Port B

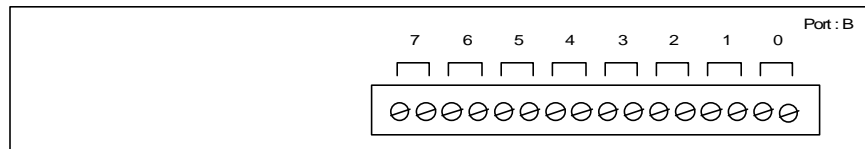

Figure 4: Enclosure Layout View

Specifications

Environmental Specifications

Specification	Operating	Storage
Temperature Range	0° to 70° C (32° to 158° F)	-20° to 70° C (-4° to 158° F)
Humidity Range	10 to 90% R.H. Non-Condensing	10 to 90% R.H. Non-Condensing

Power Consumption

Supply line	+5 VDC
Rating	500 mA

Mean Time Between Failures (MTBF)

Greater than 150,000 hours. (Calculated)

Appendix A - Troubleshooting

Following these simple steps can eliminate most common problems.

Install software **first**. After installing the software then proceed to adding the hardware. This places the required installation files in the correct locations.

1. Read this manual thoroughly before attempting to install the adapter in your system.
2. Use Device Manager under Windows to verify proper installation.
3. Use the SeaIO control panel applet for card identification and configuration.

If these steps do not solve your problem, please call Sealevel Systems' Technical Support, (864) 843-4343. Our technical support is free and available from 8:00AM-5PM Eastern Time Monday through Friday.

Appendix B - How To Get Assistance

1. Begin by reading through the Trouble Shooting Guide in Appendix A. If assistance is still needed please see below.
2. When calling for technical assistance, please have your user manual and current adapter settings. If possible, please have the adapter installed in a computer ready to run diagnostics.
3. Sealevel Systems provides an FAQ section on its web site. Please refer to this for many commonly asked questions. This section can be found at <http://www.sealevel.com/faq.htm>.
4. Visit Sealevel's website at www.sealevel.com for the latest software updates and newest manuals.
5. Technical support is available Monday to Friday from 8:00 a.m. to 5:00 p.m. eastern time. Technical support can be reached at (864) 843-4343.

RETURN AUTHORIZATION MUST BE OBTAINED FROM SEALEVEL SYSTEMS BEFORE RETURNED MERCHANDISE WILL BE ACCEPTED. AUTHORIZATION CAN BE OBTAINED BY CALLING SEALEVEL SYSTEMS AND REQUESTING A RETURN MERCHANDISE AUTHORIZATION (RMA) NUMBER.

Appendix C - Silk-Screen

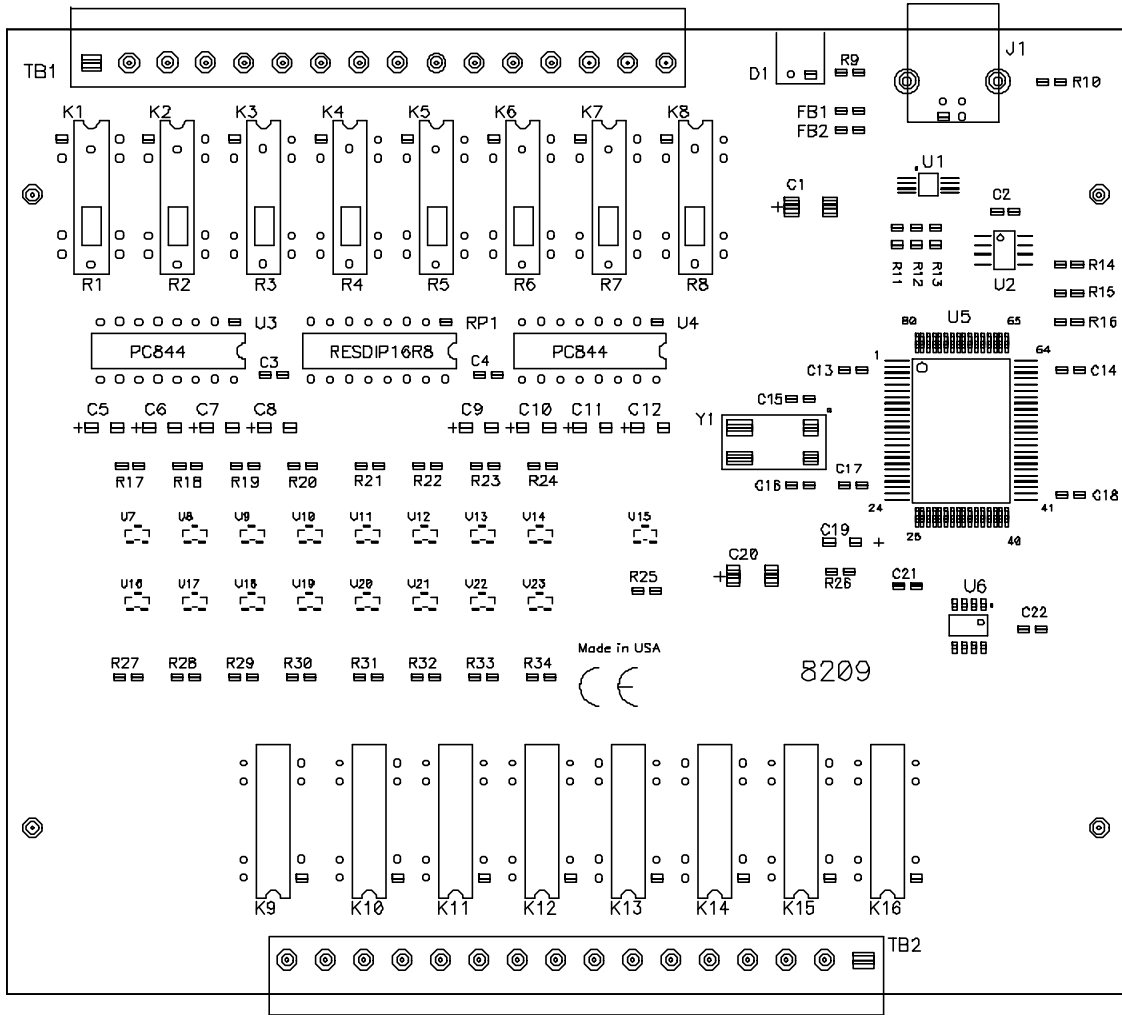

Appendix D - Compliance Notices

Federal Communications Commission Statement

FCC - This equipment has been tested and found to comply with the limits for Class A digital device, pursuant to Part 15 of the FCC Rules. These limits are designed to provide reasonable protection against harmful interference when the equipment is operated in a commercial environment. This equipment generates, uses, and can radiate radio frequency energy and, if not installed and used in accordance with the instruction manual, may cause harmful interference to radio communications. Operation of this equipment in a residential area is likely to cause harmful interference. In such case the user will be required to correct the interference at his own expense.

EMC Directive Statement



Products bearing the CE Label fulfill the requirements of the EMC directive (89/336/EEC) and of the low-voltage directive (73/23/EEC) issued by the European Commission.

To obey these directives, the following European standards must be met:

- **EN55022 Class A** - "Limits and methods of measurement of radio interference characteristics of information technology equipment"
- **EN55024** - 'Information technology equipment Immunity characteristics Limits and methods of measurement'
- **EN60950 (IEC950)** - "Safety of information technology equipment, including electrical business equipment"

Warning

This is a Class A Product. In a domestic environment this product may cause radio interference in which case the user may be required to take adequate measures.

Always use cabling provided with this product if possible. If no cable is provided or if an alternate cable is required, use high quality shielded cabling to maintain compliance with FCC/EMC directives.

Warranty



Sealevel Systems, Inc. provides a limited lifetime warranty. Should this product fail to be in good working order at any time during this period, Sealevel Systems will, at its option, replace or repair it at no additional charge except as set forth in the following terms. This warranty does not apply to products damaged by misuse, modifications, accident or disaster.

Sealevel Systems assumes no liability for any damages, lost profits, lost savings or any other incidental or consequential damage resulting from the use, misuse of, or inability to use this product. Sealevel Systems will not be liable for any claim made by any other related party.

RETURN AUTHORIZATION MUST BE OBTAINED FROM SEALEVEL SYSTEMS BEFORE RETURNED MERCHANDISE WILL BE ACCEPTED. AUTHORIZATION CAN BE OBTAINED BY CALLING SEALEVEL SYSTEMS AND REQUESTING A RETURN MERCHANDISE AUTHORIZATION (RMA) NUMBER.

Sealevel Systems, Incorporated
155 Technology Place
P.O. Box 830
Liberty, SC 29657 USA
(864) 843-4343 FAX:(864) 843-3067
www.sealevel.com
email: support@sealevel.com

Technical Support is available from 8 a.m. to 5 p.m. Eastern time.
Monday - Friday

Trademarks

Sealevel Systems, Incorporated acknowledges that all trademarks referenced in this manual are the service mark, trademark, or registered trademark of the respective company.

SeaPORT DIO-16 is a trademark of Sealevel Systems, Incorporated.