

## Features

- 15 ns pin-to-pin logic delays on all pins
- $f_{CNT}$  to 95 MHz
- 288 macrocells with 6,400 usable gates
- Up to 192 user I/O pins
- 5 V in-system programmable
  - Endurance of 10,000 program/erase cycles
  - Program/erase over full commercial voltage and temperature range
- Enhanced pin-locking architecture
- Flexible 36V18 Function Block
  - 90 product terms drive any or all of 18 macrocells within Function Block
  - Global and product term clocks, output enables, set and reset signals
- Extensive IEEE Std 1149.1 boundary-scan (JTAG) support
- Programmable power reduction mode in each macrocell
- Slew rate control on individual outputs
- User programmable ground pin capability
- Extended pattern security features for design protection
- High-drive 24 mA outputs
- 3.3 V or 5 V I/O capability
- PCI compliant (-10 speed grade)
- Advanced CMOS 5V FastFLASH technology
- Supports parallel programming of more than one XC9500 concurrently
- Available in 352-pin BGA and 208-pin HQFP packages

## Description

The XC95288 is a high-performance CPLD providing advanced in-system programming and test capabilities for general purpose logic integration. It is comprised of sixteen 36V18 Function Blocks, providing 6,400 usable gates with propagation delays of 10 ns. See Figure 2 for the architecture overview.

## Power Management

Power dissipation can be reduced in the XC95288 by configuring macrocells to standard or low-power modes of operation. Unused macrocells are turned off to minimize power dissipation.

Operating current for each design can be approximated for specific operating conditions using the following equation:

$$I_{CC} \text{ (mA)} =$$

$$MC_{HP} (1.7) + MC_{LP} (0.9) + MC (0.006 \text{ mA/MHz}) f$$

Where:

$MC_{HP}$  = Macrocells in high-performance mode

$MC_{LP}$  = Macrocells in low-power mode

$MC$  = Total number of macrocells used

$f$  = Clock frequency (MHz)

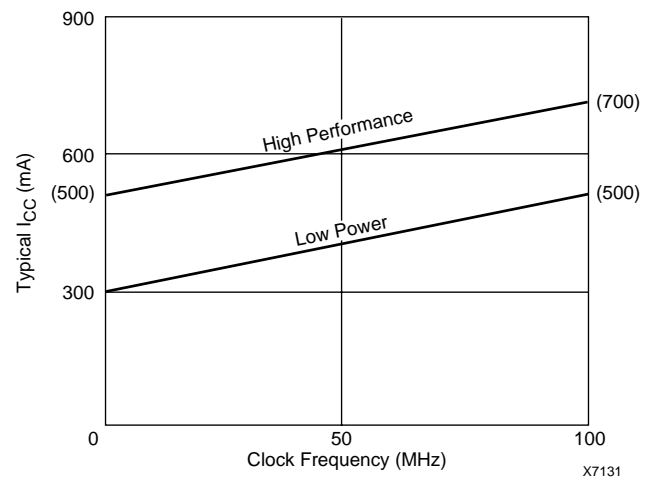
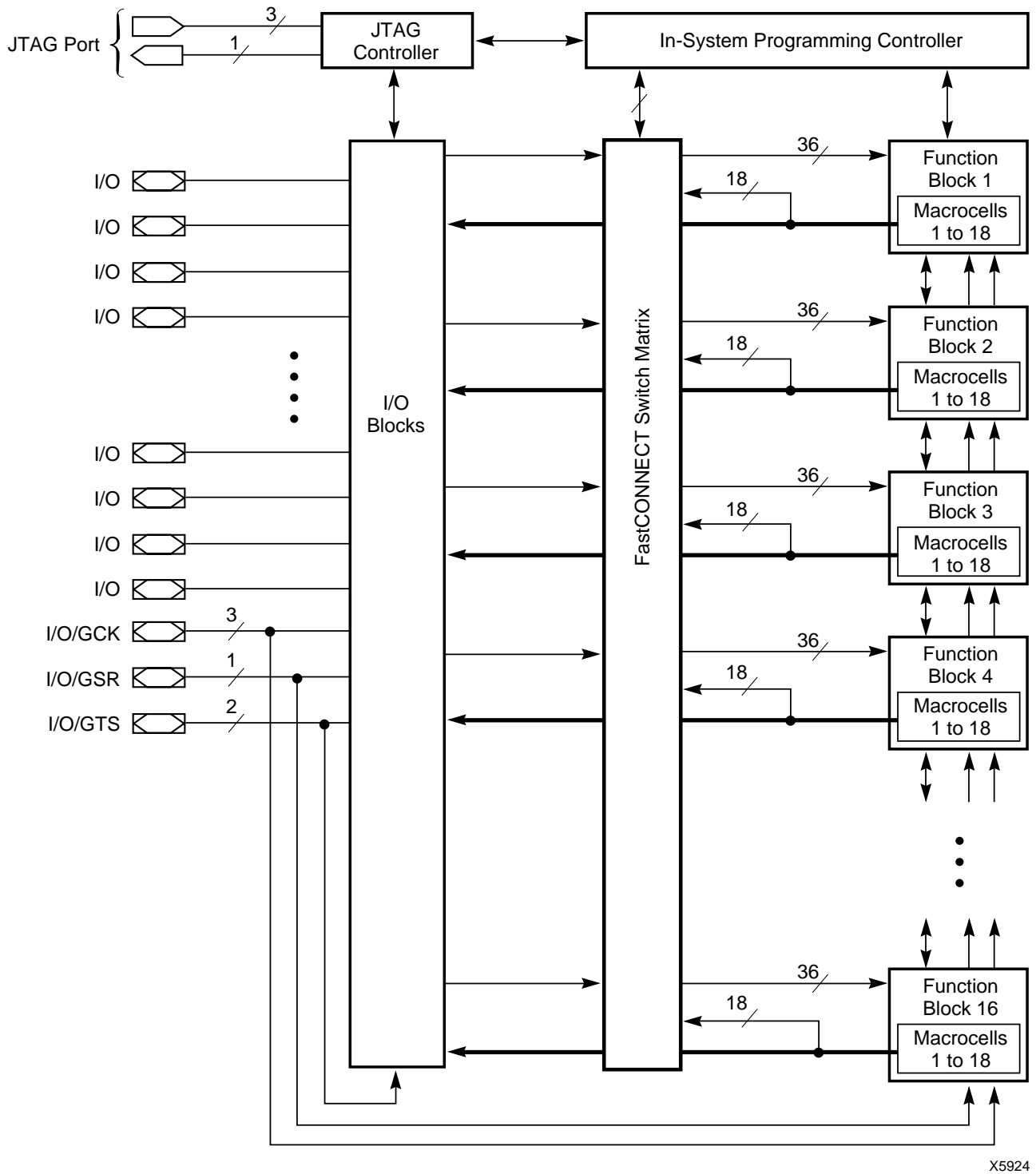

Figure 1: Typical  $I_{CC}$  vs. Frequency For XC95288



**Figure 2: XC95288 Architecture**

**Note:** Function Block outputs (indicated by the bold line) drive the I/O Blocks directly

## Absolute Maximum Ratings

Symbol	Parameter	Value	Units
$V_{CC}$	Supply voltage relative to GND	-0.5 to 7.0	V
$V_{IN}$	DC input voltage relative to GND	-0.5 to $V_{CC} + 0.5$	V
$V_{TS}$	Voltage applied to 3-state output with respect to GND	-0.5 to $V_{CC} + 0.5$	V
$T_{STG}$	Storage temperature	-65 to +150	°C
$T_{SOL}$	Max soldering temperature (10 s @ 1/16 in = 1.5 mm)	+260	°C

**Warning:** Stresses beyond those listed under Absolute Maximum Ratings may cause permanent damage to the device. These are stress ratings only, and functional operation of the device at these or any other conditions beyond those listed under Recommended Operating Conditions is not implied. Exposure to Absolute Maximum Rating conditions for extended periods of time may affect device reliability.

## Recommended Operation Conditions<sup>1</sup>

Symbol	Parameter	Min	Max	Units
$V_{CCINT}$	Supply voltage for internal logic and input buffer	4.75 (4.5)	5.25 (5.5)	V
$V_{CCIO}$	Supply voltage for output drivers for 5 V operation	4.75 (4.5)	5.25 (5.5)	V
	Supply voltage for output drivers for 3.3 V operation	3.0	3.6	V
$V_{IL}$	Low-level input voltage	0	0.80	V
$V_{IH}$	High-level input voltage	2.0	$V_{CCINT} + 0.5$	V
$V_O$	Output voltage	0	$V_{CCIO}$	V

**Note:** 1. Numbers in parenthesis are for industrial-temperature range versions.

## Endurance Characteristics

Symbol	Parameter	Min	Max	Units
$t_{DR}$	Data Retention	20	-	Years
$N_{PE}$	Program/Erase Cycles	10,000	-	Cycles

## DC Characteristics Over Recommended Operating Conditions

Symbol	Parameter	Test Conditions	Min	Max	Units
V <sub>OH</sub>	Output high voltage for 5 V operation	I <sub>OH</sub> = -4.0 mA V <sub>CC</sub> = Min	2.4		V
	Output high voltage for 3.3 V operation	I <sub>OH</sub> = -3.2 mA V <sub>CC</sub> = Min	2.4		V
V <sub>OL</sub>	Output low voltage for 5 V operation	I <sub>OL</sub> = 24 mA V <sub>CC</sub> = Min		0.5	V
	Output low voltage for 3.3 V operation	I <sub>OL</sub> = 10 mA V <sub>CC</sub> = Min		0.4	V
I <sub>IL</sub>	Input leakage current	V <sub>CC</sub> = Max V <sub>IN</sub> = GND or V <sub>CC</sub>		±10.0	μA
I <sub>IH</sub>	I/O high-Z leakage current	V <sub>CC</sub> = Max V <sub>IN</sub> = GND or V <sub>CC</sub>		±10.0	μA
C <sub>IN</sub>	I/O capacitance	V <sub>IN</sub> = GND f = 1.0 MHz		10.0	pF
I <sub>CC</sub>	Operating Supply Current (low power mode, active)	V <sub>I</sub> = GND, No load f = 1.0 MHz	300 (Typ)		ma

## AC Characteristics

Symbol	Parameter	XC95288-15		XC95288-20		Units
		Min	Max	Min	Max	
t <sub>PD</sub>	I/O to output valid		15.0		20.0	ns
t <sub>SU</sub>	I/O setup time before GCK	8.0		10.0		ns
t <sub>H</sub>	I/O hold time after GCK	0.0		0.0		ns
t <sub>CO</sub>	GCK to output valid		8.0		10.0	ns
f <sub>CNT</sub> <sup>1</sup>	16-bit counter frequency	95		83		MHz
f <sub>SYSTEM</sub> <sup>2</sup>	Multiple FB internal operating frequency	56		50		MHz
t <sub>PSU</sub>	I/O setup time before p-term clock input	4.0		4.0		ns
t <sub>PH</sub>	I/O hold time after p-term clock input	4.0		6.0		ns
t <sub>PCO</sub>	P-term clock to output valid		12.0		16.0	ns
t <sub>OE</sub>	GTS to output valid		15.0		20.0	ns
t <sub>OD</sub>	GTS to output disable		15.0		20.0	ns
t <sub>POE</sub>	Product term OE to output enabled		18.0		22.0	ns
t <sub>POD</sub>	Product term OE to output disabled		18.0		22.0	ns
t <sub>WLH</sub>	GCK pulse width (High or Low)		5.5		5.5	ns

- Note:**
- f<sub>CNT</sub> is the fastest 16-bit counter frequency available, using the local feedback when applicable.  
f<sub>CNT</sub> is also the Export Control Maximum flip-flop toggle rate, f<sub>TOG</sub>.
  - f<sub>SYSTEM</sub> is the internal operating frequency for general purpose system designs spanning multiple FBs.

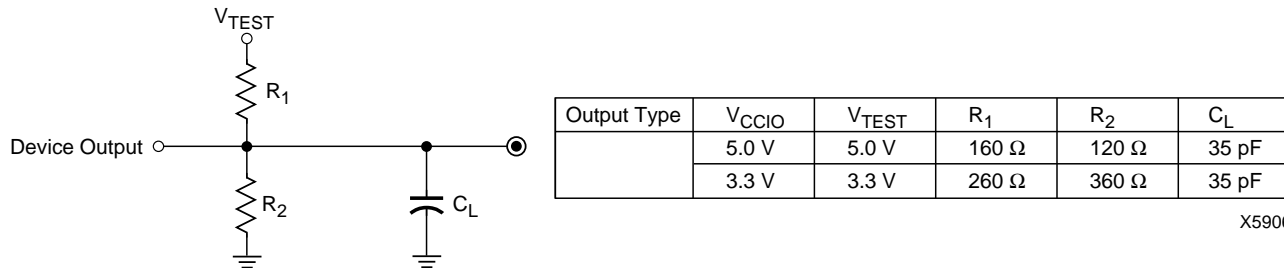

X5906

Figure 3: AC Load Circuit

## Internal Timing Parameters

Symbol	Parameter	XC95288-15		XC95288-20		Units
		Min	Max	Min	Max	
<b>Buffer Delays</b>						
t <sub>IN</sub>	Input buffer delay		4.5		6.5	ns
t <sub>GCK</sub>	GCK buffer delay		3.0		3.0	ns
t <sub>GSR</sub>	GSR buffer delay		7.5		9.5	ns
t <sub>GTS</sub>	GTS buffer delay		15.0		20.0	ns
t <sub>OUT</sub>	Output buffer delay		4.5		6.5	ns
t <sub>EN</sub>	Output buffer enable/disable delay		0.0		0.0	ns
<b>Product Term Control Delays</b>						
t <sub>PTCK</sub>	Product term clock delay		2.5		2.5	ns
t <sub>PTSR</sub>	Product term set/reset delay		3.0		3.0	ns
t <sub>PTTS</sub>	Product term 3-state delay		13.5		15.5	ns
<b>Internal Register and Combinatorial delays</b>						
t <sub>PDI</sub>	Combinatorial logic propagation delay		3.0		4.0	ns
t <sub>SUI</sub>	Register setup time	3.5		3.5		ns
t <sub>HI</sub>	Register hold time	4.5		6.5		ns
t <sub>COI</sub>	Register clock to output valid time		0.5		0.5	ns
t <sub>AOI</sub>	Register async. S/R to output delay		8.0		9.0	ns
t <sub>RAI</sub>	Register async. S/R recovery before clock	15.0		20.0		ns
t <sub>LOGI</sub>	Internal logic delay		3.0		3.0	ns
t <sub>LOGILP</sub>	Internal low power logic delay		11.5		11.5	ns
<b>Feedback Delays</b>						
t <sub>F</sub>	FastCONNECT matrix feedback delay		11.0		13.0	ns
t <sub>LF</sub>	Function Block local feedback delay		3.5		5.0	ns
<b>Time Adders</b>						
t <sub>PTA</sub> <sup>3</sup>	Incremental Product Term Allocator delay		1.5		1.5	ns
t <sub>SLEW</sub>	Slew-rate limited delay		5.0		5.5	ns

**Note:** 3. t<sub>PTA</sub> is multiplied by the span of the function as defined in the family data sheet.

## XC95288 I/O Pins

Function Block	Macrocell	HQ208	BG352	BScan Order	Notes
1	1	–	–	861	
1	2	28	N26	858	
1	3	29	P25	855	
1	4	–	–	852	
1	5	30	P23	849	
1	6	31	P24	846	
1	7	–	–	843	
1	8	32	R26	840	
1	9	–	R25	837	
1	10	33	R24	834	
1	11	–	R23	831	
1	12	34	T26	828	
1	13	–	–	825	
1	14	35	T25	822	
1	15	36	T23	819	
1	16	–	–	816	
1	17	37	V26	813	
1	18	–	–	810	
2	1	–	–	807	
2	2	15	K23	804	
2	3	16	K24	801	
2	4	–	–	798	
2	5	17	J25	795	
2	6	18	L24	792	
2	7	–	–	789	
2	8	19	K25	786	
2	9	–	L25	783	
2	10	20	L26	780	
2	11	–	M23	777	
2	12	21	M24	774	
2	13	–	–	771	
2	14	22	M25	768	
2	15	23	M26	765	
2	16	–	–	762	
2	17	25	N25	759	
2	18	–	–	756	

Function Block	Macrocell	HQ208	BG352	BScan Order	Notes
3	1	–	–	753	
3	2	38	U24	750	
3	3	39	U23	747	
3	4	–	–	744	
3	5	40	Y26	741	
3	6	41	W25	738	
3	7	–	–	735	
3	8	43	AA26	732	
3	9	–	Y25	729	
3	10	44	Y24	726	[1]
3	11	–	AA25	723	
3	12	45	AB25	720	
3	13	–	–	717	
3	14	46	AA24	714	[1]
3	15	47	Y23	711	
3	16	–	–	708	
3	17	48	AC26	705	
3	18	–	–	702	
4	1	–	–	699	
4	2	3	E23	696	[1]
4	3	4	C26	693	
4	4	–	–	690	
4	5	5	E24	687	[1]
4	6	6	F24	684	
4	7	–	–	681	
4	8	7	E25	678	[1]
4	9	–	D26	675	
4	10	8	G24	672	
4	11	–	F25	669	
4	12	9	F26	666	[1]
4	13	–	–	663	
4	14	10	H23	660	
4	15	12	G26	657	
4	16	–	–	654	
4	17	14	H25	651	
4	18	–	–	648	

**Notes:** [1] Global control pin

Macrocell outputs to package pins subject to change, contact factory for latest information. Power, GND, JTAG and Global Signals are fixed.

## XC95288 I/O Pins (continued)

Function Block	Macrocell	HQ208	BG352	BScan Order	Notes
5	1	–	–	645	
5	2	49	AA23	642	
5	3	50	AB24	639	
5	4	–	–	636	
5	5	51	AD25	633	
5	6	54	AE24	630	
5	7	–	–	627	
5	8	55	AD23	624	[1]
5	9	–	AC22	621	
5	10	56	AF24	618	
5	11	–	AD22	615	
5	12	57	AE23	612	
5	13	–	–	609	
5	14	58	AE22	606	
5	15	60	AE21	603	
5	16	–	–	600	
5	17	61	AF21	597	
5	18	–	–	594	
6	1	–	–	591	
6	2	197	C19	588	
6	3	198	D18	585	
6	4	–	–	582	
6	5	199	A21	579	
6	6	200	B20	576	
6	7	–	–	573	
6	8	201	C20	570	
6	9	–	B21	567	
6	10	202	B22	564	
6	11	–	C21	561	
6	12	203	D20	558	
6	13	–	–	555	
6	14	205	B24	552	
6	15	206	C23	549	[1]
6	16	–	–	546	
6	17	208	D22	543	
6	18	–	–	540	

Function Block	Macrocell	HQ208	BG352	BScan Order	Notes
7	1	–	–	537	
7	2	62	AC19	534	
7	3	63	AD19	531	
7	4	–	–	528	
7	5	64	AE20	525	
7	6	66	AC18	522	
7	7	–	–	519	
7	8	67	AD18	516	
7	9	–	AE19	513	
7	10	69	AD17	510	
7	11	–	AE18	507	
7	12	70	AF18	504	
7	13	–	–	501	
7	14	71	AE17	498	
7	15	72	AE16	495	
7	16	–	–	492	
7	17	73	AF16	489	
7	18	–	–	486	
8	1	–	–	483	
8	2	186	A15	480	
8	3	187	B15	477	
8	4	–	–	474	
8	5	188	C15	471	
8	6	189	D15	468	
8	7	–	–	465	
8	8	191	A16	462	
8	9	–	B16	459	
8	10	192	C16	456	
8	11	–	B17	453	
8	12	193	C17	450	
8	13	–	–	447	
8	14	194	B18	444	
8	15	195	A20	441	
8	16	–	–	438	
8	17	196	B19	435	
8	18	–	–	432	

**Note:** [1] Global control pin

## XC95288 I/O Pins (continued)

Function Block	Macrocell	HQ208	BG352	BScan Order	Notes
9	1	–	–	429	
9	2	74	AE14	426	
9	3	75	AF14	423	
9	4	–	–	420	
9	5	76	AE13	417	
9	6	77	AC13	414	
9	7	–	–	411	
9	8	78	AD13	408	
9	9	–	AF12	405	
9	10	80	AE12	402	
9	11	82	AD12	399	
9	12	83	AC12	396	
9	13	–	–	393	
9	14	84	AF11	390	
9	15	85	AE11	387	
9	16	–	–	384	
9	17	86	AE9	381	
9	18	–	–	378	
10	1	–	–	375	
10	2	170	C10	372	
10	3	171	B9	369	
10	4	–	–	366	
10	5	173	A9	363	
10	6	174	D11	360	
10	7	–	–	357	
10	8	175	B11	354	
10	9	–	A11	351	
10	10	178	C12	348	
10	11	179	B12	345	
10	12	180	A12	342	
10	13	–	–	339	
10	14	182	A13	336	
10	15	183	B14	333	
10	16	–	–	330	
10	17	185	C14	327	
10	18	–	–	324	

Function Block	Macrocell	HQ208	BG352	BScan Order	Notes
11	1	–	–	321	
11	2	87	AD9	318	
11	3	88	AC10	315	
11	4	–	–	312	
11	5	89	AF7	309	
11	6	90	AE8	306	
11	7	–	–	303	
11	8	91	AD8	300	
11	9	–	AE7	297	
11	10	95	AD7	294	
11	11	97	AE5	291	
11	12	99	AC7	288	
11	13	–	–	285	
11	14	100	AE3	282	
11	15	101	AD4	279	
11	16	–	–	276	
11	17	102	AC5	273	
11	18	–	–	270	
12	1	–	–	267	
12	2	158	B3	264	
12	3	159	A3	261	
12	4	–	–	258	
12	5	160	D6	255	
12	6	161	C6	252	
12	7	–	–	249	
12	8	162	B5	246	
12	9	–	A4	243	
12	10	164	B6	240	
12	11	165	A6	237	
12	12	166	D8	234	
12	13	–	–	231	
12	14	167	B7	228	
12	15	168	A7	225	
12	16	–	–	222	
12	17	169	D9	219	
12	18	–	–	216	



## XC95288 I/O Pins (continued)

Function Block	Macrocell	HQ208	BG352	BScan Order	Notes
13	1	–	–	213	
13	2	103	AD3	210	
13	3	106	AD2	207	
13	4	–	–	204	
13	5	107	AC3	201	
13	6	109	AD1	198	
13	7	–	–	195	
13	8	110	AA4	192	
13	9	–	AA3	189	
13	10	111	AB2	186	
13	11	112	AC1	183	
13	12	113	AA2	180	
13	13	–	–	177	
13	14	114	AA1	174	
13	15	115	Y1	171	
13	16	–	–	168	
13	17	116	V4	165	
13	18	–	–	162	
14	1	–	–	159	
14	2	144	K3	156	
14	3	145	G1	153	
14	4	–	–	150	
14	5	146	H2	147	
14	6	147	H3	144	
14	7	–	–	141	
14	8	148	J4	138	
14	9	–	F1	135	
14	10	149	G2	132	
14	11	150	G3	129	
14	12	151	F2	126	
14	13	–	–	123	
14	14	152	E2	120	
14	15	154	D2	117	
14	16	–	–	114	
14	17	155	F4	111	
14	18	–	–	108	

Function Block	Macrocell	HQ208	BG352	BScan Order	Notes
15	1	–	–	105	
15	2	117	V3	102	
15	3	118	W2	99	
15	4	–	–	96	
15	5	119	U4	93	
15	6	120	U3	90	
15	7	–	–	87	
15	8	121	V2	84	
15	9	–	V1	81	
15	10	122	U2	78	
15	11	123	T2	75	
15	12	125	R4	72	
15	13	–	–	69	
15	14	126	R3	66	
15	15	127	R2	63	
15	16	–	–	60	
15	17	128	R1	57	
15	18	–	–	54	
16	1	–	–	51	
16	2	131	P1	48	
16	3	133	N2	45	
16	4	–	–	42	
16	5	134	N4	39	
16	6	135	N3	36	
16	7	–	–	33	
16	8	136	M1	30	
16	9	–	M2	27	
16	10	137	M3	24	
16	11	138	M4	21	
16	12	139	L1	18	
16	13	–	–	15	
16	14	140	L2	12	
16	15	142	L3	9	
16	16	–	–	6	
16	17	143	J1	3	
16	18	–	–	0	

**XC95288 Global, JTAG and Power Pins**

Pin Type	HQ208	BG352
I/O/GCK1	44	Y24
I/O/GCK2	46	AA24
I/O/GCK3	55	AD23
I/O/GTS1	7	E25
I/O/GTS2	9	F26
I/O/GTS3	3	E23
I/O/GTS4	5	E24
I/O/GSR	206	C23
TCK	98	AD6
TDI	94	AF6
TDO	176	D12
TMS	96	AE6
V <sub>CCINT</sub> 5 V	11, 59, 124, 153, 204	J23, V24, AF23, AC15, AF15, AD11, AD5, Y3, T1, J3, G4, D5, D10, B13, D17, C22, H24
V <sub>CCIO</sub> 3.3 V/5 V	1, 26, 53, 65, 79, 92, 105, 132, 157, 172, 181, 184	A10, A17, B2, B25, D7, D13, D19, G23, H4, K1, K26, N23, P4, U1, U26, W23, Y4, AC8, AC14, AC20, AE25, AF10, AF17
GND	2, 13, 24, 27, 42, 52, 68, 81, 93, 104, 108, 129, 130, 141, 156, 163, 177, 190, 207	A1, A2, A5, A8, A14, A19, A22, A25, A26, B1, B26, C7, C9, C13, C18, D24, E1, E26, H1, H26, K4, N1, N24, P3, P26, V23, W1, W4, W26, AB1, AB4, AB26, AC9, AD10, AD14, AD15, AD20, AE1, AE26, AF1, AF2, AF5, AF8, AF13, AF19, AF22, AF25, AF26
No Connects		A18, A23, A24, B4, B8, B10, B23, C1, C2, C3, C4, C5, C8, C11, C24, C25, D1, D3, D4, D14, D16, D21, D23, D25, E3, E4, F3, F23, G25, J2, J24, J26, K2, L4, L23, P2, T3, T4, T24, U25, V25, W3, W24, Y2, AB3, AB23, AC2, AC4, AC6, AC11, AC16, AC17, AC21, AC23, AC24, AC25, AD16, AD21, AD24, AD26, AE2, AE4, AE10, AE15, AF3, AF4, AF9, AF20

## Ordering Information

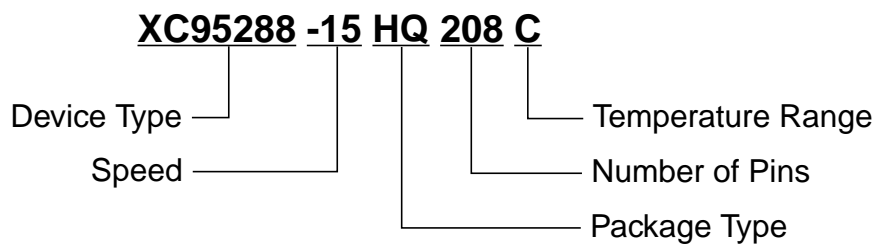

### Speed Options

- 20 20 ns pin-to-pin delay
- 15 15 ns pin-to-pin delay

### Packaging Options

- HQ208 208-Pin Heat Sink Quad Flat Pack (HQFP)
- BG352 352-Pin Plastic Ball Grid Array (BGA)

### Temperature Options

- C Commercial 0°C to 70°C
- I Industrial -40°C to 85°C

## Component Availability

Pins		208	352
Type		Plastic HQFP	Plastic BGA
Code		HQ	BG
XC95288	-20	C,I	C,I
	-15	C	C

C = Commercial = 0° to +70°C    I = Industrial = -40° to 85°C