

Device-Specific Pinout Tables

Device-specific tables include all packages for each XC4000 and XC4000X Series device. They follow the pad locations around the die, and include boundary scan register locations.

Pin Locations for XC4003E Devices

XC4003E Pad Name	PC84	PQ100	VQ100	PG120	Bndry Scan
VCC	P2	P92	P89	G3	-
I/O (A8)	P3	P93	P90	G1	32
I/O (A9)	P4	P94	P91	F1	35
I/O	-	P95	P92	E1	38
I/O	-	P96	P93	F2	41
I/O (A10)	P5	P97	P94	F3	44
I/O (A11)	P6	P98	P95	D1	47
I/O (A12)	P7	P99	P96	C1	50
I/O (A13)	P8	P100	P97	D2	53
I/O (A14)	P9	P1	P98	C2	56
I/O, SGCK1 (A15)	P10	P2	P99	D3	59
VCC	P11	P3	P100	C3	-
GND	P12	P4	P1	C4	-
I/O, PGCK1 (A16)	P13	P5	P2	B2	62
I/O (A17)	P14	P6	P3	B3	65
I/O, TDI	P15	P7	P4	C5	68
I/O, TCK	P16	P8	P5	B4	71
I/O, TMS	P17	P9	P6	B5	74
I/O	P18	P10	P7	A4	77
I/O	-	-	-	C6	80
I/O	-	P11	P8	A5	83
I/O	P19	P12	P9	B6	86
I/O	P20	P13	P10	A6	89
GND	P21	P14	P11	B7	-
VCC	P22	P15	P12	C7	-
I/O	P23	P16	P13	A7	92
I/O	P24	P17	P14	A8	95
I/O	-	P18	P15	A9	98
I/O	-	-	-	B8	101
I/O	P25	P19	P16	C8	104
I/O	P26	P20	P17	A10	107
I/O	P27	P21	P18	B9	110
I/O	-	P22	P19	A11	113
I/O	P28	P23	P20	C9	116
I/O, SGCK2	P29	P24	P21	A12	119
O (M1)	P30	P25	P22	B11	122
GND	P31	P26	P23	C10	-
I (M0)	P32	P27	P24	C11	125
VCC	P33	P28	P25	D11	-
I (M2)	P34	P29	P26	B12	126
I/O, PGCK2	P35	P30	P27	C12	127
I/O (HDC)	P36	P31	P28	A13	130
I/O	-	P32	P29	D12	133
I/O (LDC)	P37	P33	P30	C13	136
I/O	P38	P34	P31	E12	139
I/O	P39	P35	P32	D13	142
I/O	-	P36	P33	F11	145
I/O	-	P37	P34	E13	148
I/O	P40	P38	P35	F12	151
I/O (INIT)	P41	P39	P36	F13	154
VCC	P42	P40	P37	G12	-
GND	P43	P41	P38	G11	-
I/O	P44	P42	P39	G13	157
I/O	P45	P43	P40	H13	160
I/O	-	P44	P41	J13	163
I/O	-	P45	P42	H12	166
I/O	P46	P46	P43	H11	169

XC4003E Pad Name	PC84	PQ100	VQ100	PG120	Bndry Scan
I/O	P47	P47	P44	K13	172
I/O	P48	P48	P45	J12	175
I/O	P49	P49	P46	L13	178
I/O	P50	P50	P47	M13	181
I/O, SGCK3	P51	P51	P48	L12	184
GND	P52	P52	P49	K11	-
DONE	P53	P53	P50	L11	-
VCC	P54	P54	P51	L10	-
PROGRAM	P55	P55	P52	M12	-
I/O (D7)	P56	P56	P53	M11	187
I/O, PGCK3	P57	P57	P54	N13	190
I/O (D6)	P58	P58	P55	M10	193
I/O	-	P59	P56	N11	196
I/O (D5)	P59	P60	P57	M9	199
I/O (CS0)	P60	P61	P58	N10	202
I/O	-	P62	P59	L8	205
I/O	-	P63	P60	N9	208
I/O (D4)	P61	P64	P61	M8	211
I/O	P62	P65	P62	N8	214
VCC	P63	P66	P63	M7	-
GND	P64	P67	P64	L7	-
I/O (D3)	P65	P68	P65	N7	217
I/O (RS)	P66	P69	P66	N6	220
I/O	-	P70	P67	N5	223
I/O	-	-	-	M6	226
I/O (D2)	P67	P71	P68	L6	229
I/O	P68	P72	P69	N4	232
I/O (D1)	P69	P73	P70	M5	235
I/O (RCLK, RDY/BUSY)	P70	P74	P71	N3	238
I/O (D0, DIN)	P71	P75	P72	N2	241
I/O, SGCK4 (DOUT)	P72	P76	P73	M3	244
CCLK	P73	P77	P74	L4	-
VCC	P74	P78	P75	L3	-
O, TDO	P75	P79	P76	M2	0
GND	P76	P80	P77	K3	-
I/O (A0, WS)	P77	P81	P78	L2	2
I/O, PGCK4 (A1)	P78	P82	P79	N1	5
I/O (CS1, A2)	P79	P83	P80	K2	8
I/O (A3)	P80	P84	P81	L1	11
I/O (A4)	P81	P85	P82	J2	14
I/O (A5)	P82	P86	P83	K1	17
I/O	-	P87	P84	H3	20
I/O	-	P88	P85	J1	23
I/O (A6)	P83	P89	P86	H2	26
I/O (A7)	P84	P90	P87	H1	29
GND	P1	P91	P88	G2	-

5/5/97

Additional XC4003E Package Pins

PG120

N.C. Pins					
A1	A2	A3	B1	B10	B13
E2	E3	E11	J3	J11	K12
L5	L9	M1	M4	N12	-

5/5/97

Pin Locations for XC4005E/XL Devices

The following table may contain pinout information for unsupported device/package combinations. Please see the availability charts elsewhere in the XC4000 Series data sheet for availability information.

XC4005E/XL Pad Name	PC 84	PQ 100	VQ 100††	TQ 144	PG 156†	PQ 160	PQ 208	Bndry Scan
VCC	P2	P92	P89	P128	H3	P142	P183	-
I/O (A8)	P3	P93	P90	P129	H1	P143	P184	44
I/O (A9)	P4	P94	P91	P130	G1	P144	P185	47
I/O (A19) ††	-	P95	P92	P131	G2	P145	P186	50
I/O (A18) ††	-	P96	P93	P132	G3	P146	P187	53
I/O (A10)	P5	P97	P94	P133	F1	P147	P190	56
I/O (A11)	P6	P98	P95	P134	F2	P148	P191	59
I/O	-	-	-	P135	E1	P149	P192	62
I/O	-	-	-	P136	E2	P150	P193	65
GND	-	-	-	P137	F3	P151	P194	-
I/O (A12)	P7	P99	P96	P138	E3	P154	P199	68
I/O (A13)	P8	P100	P97	P139	C1	P155	P200	71
I/O	-	-	-	P140	C2	P156	P201	74
I/O	-	-	-	P141	D3	P157	P202	77
I/O (A14)	P9	P1	P98	P142	B1	P158	P203	80
I/O, SGCK1 †, GCK8 †† (A15)	P10	P2	P99	P143	B2	P159	P204	83
VCC	P11	P3	P100	P144	C3	P160	P205	-
GND	P12	P4	P1	P1	C4	P1	P2	-
I/O, PGCK1†, GCK1†† (A16)	P13	P5	P2	P2	B3	P2	P4	86
I/O (A17)	P14	P6	P3	P3	A1	P3	P5	89
I/O	-	-	-	P4	A2	P4	P6	92
I/O	-	-	-	P5	C5	P5	P7	95
I/O, TDI	P15	P7	P4	P6	B4	P6	P8	98
I/O, TCK	P16	P8	P5	P7	A3	P7	P9	101
GND	-	-	-	P8	C6	P10	P14	-
I/O	-	-	-	P9	B5	P11	P15	104
I/O	-	-	-	P10	B6	P12	P16	107
I/O, TMS	P17	P9	P6	P11	A5	P13	P17	110
I/O	P18	P10	P7	P12	C7	P14	P18	113
I/O	-	-	-	P13	B7	P15	P21	116
I/O	-	P11	P8	P14	A6	P16	P22	119
I/O	P19	P12	P9	P15	A7	P17	P23	122
I/O	P20	P13	P10	P16	A8	P18	P24	125
GND	P21	P14	P11	P17	C8	P19	P25	-
VCC	P22	P15	P12	P18	B8	P20	P26	-
I/O	P23	P16	P13	P19	C9	P21	P27	128
I/O	P24	P17	P14	P20	B9	P22	P28	131
I/O	-	P18	P15	P21	A9	P23	P29	134
I/O	-	-	-	P22	B10	P24	P30	137
I/O	P25	P19	P16	P23	C10	P25	P33	140
I/O	P26	P20	P17	P24	A10	P26	P34	143
I/O	-	-	-	P25	A11	P27	P35	146
I/O	-	-	-	P26	B11	P28	P36	149
GND	-	-	-	P27	C11	P29	P37	-
I/O	P27	P21	P18	P28	B12	P32	P42	152
I/O	-	P22	P19	P29	A13	P33	P43	155
I/O	-	-	-	P30	A14	P34	P44	158
I/O	-	-	-	P31	C12	P35	P45	161
I/O	P28	P23	P20	P32	B13	P36	P46	164
I/O, SGCK2 †, GCK2 ††	P29	P24	P21	P33	B14	P37	P47	167
O (M1)	P30	P25	P22	P34	A15	P38	P48	170
GND	P31	P26	P23	P35	C13	P39	P49	-
I (M0)	P32	P27	P24	P36	A16	P40	P50	173
VCC	P33	P28	P25	P37	C14	P41	P55	-
I (M2)	P34	P29	P26	P38	B15	P42	P56	174
I/O, PGCK2 †, GCK3 ††	P35	P30	P27	P39	B16	P43	P57	175
I/O (HDC)	P36	P31	P28	P40	D14	P44	P58	178
I/O	-	-	-	P41	C15	P45	P59	181
I/O	-	-	-	P42	D15	P46	P60	184
I/O	-	P32	P29	P43	E14	P47	P61	187
I/O (LDC)	P37	P33	P30	P44	C16	P48	P62	190

XC4005E/XL Pad Name	PC 84	PQ 100	VQ 100††	TQ 144	PG 156†	PQ 160	PQ 208	Bndry Scan
GND	-	-	-	P45	F14	P51	P67	-
I/O	-	-	-	P46	F15	P52	P68	193
I/O	-	-	-	P47	E16	P53	P69	196
I/O	P38	P34	P31	P48	F16	P54	P70	199
I/O	P39	P35	P32	P49	G14	P55	P71	202
I/O	-	P36	P33	P50	G15	P56	P74	205
I/O	-	P37	P34	P51	G16	P57	P75	208
I/O	P40	P38	P35	P52	H16	P58	P76	211
I/O (INIT)	P41	P39	P36	P53	H15	P59	P77	214
VCC	P42	P40	P37	P54	H14	P60	P78	-
GND	P43	P41	P38	P55	J14	P61	P79	-
I/O	P44	P42	P39	P56	J15	P62	P80	217
I/O	P45	P43	P40	P57	J16	P63	P81	220
I/O	-	P44	P41	P58	K16	P64	P82	223
I/O	-	P45	P42	P59	K15	P65	P83	226
I/O	P46	P46	P43	P60	K14	P66	P86	229
I/O	P47	P47	P44	P61	L16	P67	P87	232
I/O	-	-	-	P62	M16	P68	P88	235
I/O	-	-	-	P63	L15	P69	P89	238
GND	-	-	-	P64	L14	P70	P90	-
I/O	P48	P48	P45	P65	P16	P73	P95	241
I/O	P49	P49	P46	P66	M14	P74	P96	244
I/O	-	-	-	P67	N15	P75	P97	247
I/O	-	-	-	P68	P15	P76	P98	250
I/O	P50	P50	P47	P69	N14	P77	P99	253
I/O, SGCK3 †, GCK4 ††	P51	P51	P48	P70	R16	P78	P100	256
GND	P52	P52	P49	P71	P14	P79	P101	-
DONE	P53	P53	P50	P72	R15	P80	P103	-
VCC	P54	P54	P51	P73	P13	P81	P106	-
PROGRAM	P55	P55	P52	P74	R14	P82	P108	-
I/O (D7)	P56	P56	P53	P75	T16	P83	P109	259
I/O, PGCK3†, GCK5††	P57	P57	P54	P76	T15	P84	P110	262
I/O	-	-	-	P77	R13	P85	P111	265
I/O	-	-	-	P78	P12	P86	P112	268
I/O (D6)	P58	P58	P55	P79	T14	P87	P113	271
I/O	-	P59	P56	P80	T13	P88	P114	274
GND	-	-	-	P81	P11	P91	P119	-
I/O	-	-	-	P82	R11	P92	P120	277
I/O	-	-	-	P83	T11	P93	P121	280
I/O (D5)	P59	P60	P57	P84	T10	P94	P122	283
I/O (CS0)	P60	P61	P58	P85	P10	P95	P123	286
I/O	-	P62	P59	P86	R10	P96	P126	289
I/O	-	P63	P60	P87	T9	P97	P127	292
I/O (D4)	P61	P64	P61	P88	R9	P98	P128	295
I/O	P62	P65	P62	P89	P9	P99	P129	298
VCC	P63	P66	P63	P90	R8	P100	P130	-
GND	P64	P67	P64	P91	P8	P101	P131	-
I/O (D3)	P65	P68	P65	P92	T8	P102	P132	301
I/O (RS)	P66	P69	P66	P93	T7	P103	P133	304
I/O	-	P70	P67	P94	T6	P104	P134	307
I/O	-	-	-	P95	R7	P105	P135	310
I/O (D2)	P67	P71	P68	P96	P7	P106	P138	313
I/O	P68	P72	P69	P97	T5	P107	P139	316
I/O	-	-	-	P98	R6	P108	P140	319
I/O	-	-	-	P99	T4	P109	P141	322
GND	-	-	-	P100	P6	P110	P142	-
I/O (D1)	P69	P73	P70	P101	T3	P113	P147	325
I/O (RCLK, RDY/BUSY)	P70	P74	P71	P102	P5	P114	P148	328
I/O	-	-	-	P103	R4	P115	P149	331
I/O	-	-	-	P104	R3	P116	P150	334
I/O (D0, DIN)	P71	P75	P72	P105	P4	P117	P151	337

XC4005E/XL Pad Name	PC 84	PQ 100	VQ 100††	TQ 144	PG 156†	PQ 160	PQ 208	Bndry Scan
I/O, SGCK4 †, GCK6 †† (DOUT)	P72	P76	P73	P106	T2	P118	P152	340
CCLK	P73	P77	P74	P107	R2	P119	P153	-
VCC	P74	P78	P75	P108	P3	P120	P154	-
O, TDO	P75	P79	P76	P109	T1	P121	P159	0
GND	P76	P80	P77	P110	N3	P122	P160	-
I/O (A0, WS)	P77	P81	P78	P111	R1	P123	P161	2
I/O, PGCK4 †, GCK7 †† (A1)	P78	P82	P79	P112	P2	P124	P162	5
I/O	-	-	-	P113	N2	P125	P163	8
I/O	-	-	-	P114	M3	P126	P164	11
I/O (CS1, A2)	P79	P83	P80	P115	P1	P127	P165	14
I/O (A3)	P80	P84	P81	P116	N1	P128	P166	17
GND	-	-	-	P118	L3	P131	P171	-
I/O	-	-	-	P119	L2	P132	P172	20
I/O	-	-	-	P120	L1	P133	P173	23
I/O (A4)	P81	P85	P82	P121	K3	P134	P174	26
I/O (A5)	P82	P86	P83	P122	K2	P135	P175	29
I/O (A21) ††	-	P87	P84	P123	K1	P137	P178	32
I/O (A20) ††	-	P88	P85	P124	J1	P138	P179	35
I/O (A6)	P83	P89	P86	P125	J2	P139	P180	38
I/O (A7)	P84	P90	P87	P126	J3	P140	P181	41
GND	P1	P91	P88	P127	H2	P141	P182	-

6/10/97

† = E only

†† = XL only

Additional XC4005E/XL Package Pins

TQ144

N.C. Pins							
P117	-	-	-	-	-	-	-

5/5/97

PG156

N.C. Pins					
A4	A12	D1	D2	D16	E15
M1	M2	M15	N16	R5	R12
T12	-	-	-	-	-

5/5/97

PQ160

N.C. Pins					
P8	P9	P30	P31	P49	P50
P71	P72	P89	P90	P111	P112
P129	P130	P136	P152	P153	-

6/16/97

PQ208

N.C. Pins					
P1	P3	P10	P11	P12	P13
P19	P20	P31	P32	P38	P39
P40	P41	P51	P52	P53	P54
P63	P64	P65	P66	P72	P73
P84	P85	P91	P92	P93	P94
P102	P104	P105	P107	P115	P116
P117	P118	P124	P125	P136	P137
P143	P144	P145	P146	P155	P156
P157	P158	P167	P168	P169	P170
P176	P177	P188	P189	P195	P196
P197	P198	P206	P207	P208	-

6/5/97

Pin Locations for XC4006E Devices

XC4006E Pad Name	PC 84	TQ 144	PG 156	PQ 160	PQ 208	Bndry Scan
VCC	P2	P128	H3	P142	P183	-
I/O (A8)	P3	P129	H1	P143	P184	50
I/O (A9)	P4	P130	G1	P144	P185	53
I/O	-	P131	G2	P145	P186	56
I/O	-	P132	G3	P146	P187	59
I/O (A10)	P5	P133	F1	P147	P190	62
I/O (A11)	P6	P134	F2	P148	P191	65
I/O	-	P135	E1	P149	P192	68
I/O	-	P136	E2	P150	P193	71
GND	-	P137	F3	P151	P194	-
I/O	-	-	D1	P152	P197	74
I/O	-	-	D2	P153	P198	77
I/O (A12)	P7	P138	E3	P154	P199	80
I/O (A13)	P8	P139	C1	P155	P200	83
I/O	-	P140	C2	P156	P201	86
I/O	-	P141	D3	P157	P202	89
I/O (A14)	P9	P142	B1	P158	P203	92
I/O, SGCK1 (A15)	P10	P143	B2	P159	P204	95
VCC	P11	P144	C3	P160	P205	-
GND	P12	P1	C4	P1	P2	-
I/O, PGCK1 (A16)	P13	P2	B3	P2	P4	98
I/O (A17)	P14	P3	A1	P3	P5	101
I/O	-	P4	A2	P4	P6	104
I/O	-	P5	C5	P5	P7	107
I/O, TDI	P15	P6	B4	P6	P8	110
I/O, TCK	P16	P7	A3	P7	P9	113
I/O	-	-	A4	P8	P10	116
I/O	-	-	-	P9	P11	119
GND	-	P8	C6	P10	P14	-

XC4006E Pad Name	PC 84	TQ 144	PG 156	PQ 160	PQ 208	Bndry Scan
I/O	-	P9	B5	P11	P15	122
I/O	-	P10	B6	P12	P16	125
I/O, TMS	P17	P11	A5	P13	P17	128
I/O	P18	P12	C7	P14	P18	131
I/O	-	P13	B7	P15	P21	134
I/O	-	P14	A6	P16	P22	137
I/O	P19	P15	A7	P17	P23	140
I/O	P20	P16	A8	P18	P24	143
GND	P21	P17	C8	P19	P25	-
VCC	P22	P18	B8	P20	P26	-
I/O	P23	P19	C9	P21	P27	146
I/O	P24	P20	B9	P22	P28	149
I/O	-	P21	A9	P23	P29	152
I/O	-	P22	B10	P24	P30	155
I/O	P25	P23	C10	P25	P33	158
I/O	P26	P24	A10	P26	P34	161
I/O	-	P25	A11	P27	P35	164
I/O	-	P26	B11	P28	P36	167
GND	-	P27	C11	P29	P37	-
I/O	-	-	A12	P30	P40	170
I/O	-	-	-	P31	P41	173
I/O	P27	P28	B12	P32	P42	176
I/O	-	P29	A13	P33	P43	179
I/O	-	P30	A14	P34	P44	182
I/O	-	P31	C12	P35	P45	185
I/O	P28	P32	B13	P36	P46	188
I/O, SGCK2	P29	P33	B14	P37	P47	191
O (M1)	P30	P34	A15	P38	P48	194
GND	P31	P35	C13	P39	P49	-

XC4006E Pad Name	PC 84	TQ 144	PG 156	PQ 160	PQ 208	Bndry Scan
I (M0)	P32	P36	A16	P40	P50	197
VCC	P33	P37	C14	P41	P55	-
I (M2)	P34	P38	B15	P42	P56	198
I/O, PGCK2	P35	P39	B16	P43	P57	199
I/O (HDC)	P36	P40	D14	P44	P58	202
I/O	-	P41	C15	P45	P59	205
I/O	-	P42	D15	P46	P60	208
I/O	-	P43	E14	P47	P61	211
I/O (LDC)	P37	P44	C16	P48	P62	214
I/O	-	-	E15	P49	P63	217
I/O	-	-	D16	P50	P64	220
GND	-	P45	F14	P51	P67	-
I/O	-	P46	F15	P52	P68	223
I/O	-	P47	E16	P53	P69	226
I/O	P38	P48	F16	P54	P70	229
I/O	P39	P49	G14	P55	P71	232
I/O	-	P50	G15	P56	P74	235
I/O	-	P51	G16	P57	P75	238
I/O	P40	P52	H16	P58	P76	241
I/O (INIT)	P41	P53	H15	P59	P77	244
VCC	P42	P54	H14	P60	P78	-
GND	P43	P55	J14	P61	P79	-
I/O	P44	P56	J15	P62	P80	247
I/O	P45	P57	J16	P63	P81	250
I/O	-	P58	K16	P64	P82	253
I/O	-	P59	K15	P65	P83	256
I/O	P46	P60	K14	P66	P86	259
I/O	P47	P61	L16	P67	P87	262
I/O	-	P62	M16	P68	P88	265
I/O	-	P63	L15	P69	P89	268
GND	-	P64	L14	P70	P90	-
I/O	-	-	N16	P71	P93	271
I/O	-	-	M15	P72	P94	274
I/O	P48	P65	P16	P73	P95	277
I/O	P49	P66	M14	P74	P96	280
I/O	-	P67	N15	P75	P97	283
I/O	-	P68	P15	P76	P98	286
I/O	P50	P69	N14	P77	P99	289
I/O, SGCK3	P51	P70	R16	P78	P100	292
GND	P52	P71	P14	P79	P101	-
DONE	P53	P72	R15	P80	P103	-
VCC	P54	P73	P13	P81	P106	-
PROGRAM	P55	P74	R14	P82	P108	-
I/O (D7)	P56	P75	T16	P83	P109	295
I/O, PGCK3	P57	P76	T15	P84	P110	298
I/O	-	P77	R13	P85	P111	301
I/O	-	P78	P12	P86	P112	304
I/O (D6)	P58	P79	T14	P87	P113	307
I/O	-	P80	T13	P88	P114	310
I/O	-	-	R12	P89	P115	313
I/O	-	-	T12	P90	P116	316
GND	-	P81	P11	P91	P119	-
I/O	-	P82	R11	P92	P120	319
I/O	-	P83	T11	P93	P121	322
I/O (D5)	P59	P84	T10	P94	P122	325
I/O (CS0)	P60	P85	P10	P95	P123	328
I/O	-	P86	R10	P96	P126	331
I/O	-	P87	T9	P97	P127	334
I/O (D4)	P61	P88	R9	P98	P128	337
I/O	P62	P89	P9	P99	P129	340
VCC	P63	P90	R8	P100	P130	-
GND	P64	P91	P8	P101	P131	-
I/O (D3)	P65	P92	T8	P102	P132	343
I/O (RS)	P66	P93	T7	P103	P133	346

XC4006E Pad Name	PC 84	TQ 144	PG 156	PQ 160	PQ 208	Bndry Scan
I/O	-	P94	T6	P104	P134	349
I/O	-	P95	R7	P105	P135	352
I/O (D2)	P67	P96	P7	P106	P138	355
I/O	P68	P97	T5	P107	P139	358
I/O	-	P98	R6	P108	P140	361
I/O	-	P99	T4	P109	P141	364
GND	-	P100	P6	P110	P142	-
I/O	-	-	R5	P111	P145	367
I/O	-	-	-	P112	P146	370
I/O (D1)	P69	P101	T3	P113	P147	373
I/O (RCLK, RDY/BUSY)	P70	P102	P5	P114	P148	376
I/O	-	P103	R4	P115	P149	379
I/O	-	P104	R3	P116	P150	382
I/O (D0, DIN)	P71	P105	P4	P117	P151	385
I/O, SGCK4 (DOUT)	P72	P106	T2	P118	P152	388
CCLK	P73	P107	R2	P119	P153	-
VCC	P74	P108	P3	P120	P154	-
O, TDO	P75	P109	T1	P121	P159	0
GND	P76	P110	N3	P122	P160	-
I/O (A0, WS)	P77	P111	R1	P123	P161	2
I/O, PGCK4 (A1)	P78	P112	P2	P124	P162	5
I/O	-	P113	N2	P125	P163	8
I/O	-	P114	M3	P126	P164	11
I/O (CS1, A2)	P79	P115	P1	P127	P165	14
I/O (A3)	P80	P116	N1	P128	P166	17
I/O	-	P117	M2	P129	P167	20
I/O	-	-	M1	P130	P168	23
GND	-	P118	L3	P131	P171	-
I/O	-	P119	L2	P132	P172	26
I/O	-	P120	L1	P133	P173	29
I/O (A4)	P81	P121	K3	P134	P174	32
I/O (A5)	P82	P122	K2	P135	P175	35
I/O	-	P123	K1	P137	P178	38
I/O	-	P124	J1	P138	P179	41
I/O (A6)	P83	P125	J2	P139	P180	44
I/O (A7)	P84	P126	J3	P140	P181	47
GND	P1	P127	H2	P141	P182	-

5/5/97

Additional XC4006E Package Pins

PQ160

N.C. Pins				
P136	-	-	-	-

5/5/97

PQ208

N.C. Pins				
P1	P3	P12	P13	P19
P20	P31	P32	P38	P39
P51	P52	P53	P54	P65
P66	P72	P73	P84	P85
P91	P92	P102	P104	P105
P107	P117	P118	P124	P125
P136	P137	P143	P144	P155
P156	P157	P158	P169	P170
P176	P177	P188	P189	P195
P196	P206	P207	P208	-

6/5/97

Pin Locations for XC4008E Devices

XC4008E Pad Name	PC84	PQ160	PG191	PQ208	Bndry Scan
VCC	P2	P142	J4	P183	-
I/O (A8)	P3	P143	J3	P184	56
I/O (A9)	P4	P144	J2	P185	59
I/O	-	P145	J1	P186	62
I/O	-	P146	H1	P187	65
I/O	-	-	H2	P188	68
I/O	-	-	H3	P189	71
I/O (A10)	P5	P147	G1	P190	74
I/O (A11)	P6	P148	G2	P191	77
I/O	-	P149	F1	P192	80
I/O	-	P150	E1	P193	83
GND	-	P151	G3	P194	-
I/O	-	P152	C1	P197	86
I/O	-	P153	E2	P198	89
I/O (A12)	P7	P154	F3	P199	92
I/O (A13)	P8	P155	D2	P200	95
I/O	-	P156	B1	P201	98
I/O	-	P157	E3	P202	101
I/O (A14)	P9	P158	C2	P203	104
I/O, SGCK1 (A15)	P10	P159	B2	P204	107
VCC	P11	P160	D3	P205	-
GND	P12	P1	D4	P2	-
I/O, PGCK1 (A16)	P13	P2	C3	P4	110
I/O (A17)	P14	P3	C4	P5	113
I/O	-	P4	B3	P6	116
I/O	-	P5	C5	P7	119
I/O, TDI	P15	P6	A2	P8	122
I/O, TCK	P16	P7	B4	P9	125
I/O	-	P8	C6	P10	128
I/O	-	P9	A3	P11	131
GND	-	P10	C7	P14	-
I/O	-	P11	A4	P15	134
I/O	-	P12	A5	P16	137
I/O, TMS	P17	P13	B7	P17	140
I/O	P18	P14	A6	P18	143
I/O	-	-	C8	P19	146
I/O	-	-	A7	P20	149
I/O	-	P15	B8	P21	152
I/O	-	P16	A8	P22	155
I/O	P19	P17	B9	P23	158
I/O	P20	P18	C9	P24	161
GND	P21	P19	D9	P25	-
VCC	P22	P20	D10	P26	-
I/O	P23	P21	C10	P27	164
I/O	P24	P22	B10	P28	167
I/O	-	P23	A9	P29	170
I/O	-	P24	A10	P30	173
I/O	-	-	A11	P31	176
I/O	-	-	C11	P32	179
I/O	P25	P25	B11	P33	182
I/O	P26	P26	A12	P34	185
I/O	-	P27	B12	P35	188
I/O	-	P28	A13	P36	191
GND	-	P29	C12	P37	-
I/O	-	P30	A15	P40	194
I/O	-	P31	C13	P41	197
I/O	P27	P32	B14	P42	200
I/O	-	P33	A16	P43	203
I/O	-	P34	B15	P44	206
I/O	-	P35	C14	P45	209
I/O	P28	P36	A17	P46	212
I/O, SGCK2	P29	P37	B16	P47	215
O (M1)	P30	P38	C15	P48	218
GND	P31	P39	D15	P49	-
I (M0)	P32	P40	A18	P50	221
VCC	P33	P41	D16	P55	-
I (M2)	P34	P42	C16	P56	222
I/O, PGCK2	P35	P43	B17	P57	223

XC4008E Pad Name	PC84	PQ160	PG191	PQ208	Bndry Scan
I/O (HDC)	P36	P44	E16	P58	226
I/O	-	P45	C17	P59	229
I/O	-	P46	D17	P60	232
I/O	-	P47	B18	P61	235
I/O (LDC)	P37	P48	E17	P62	238
I/O	-	P49	F16	P63	241
I/O	-	P50	C18	P64	244
GND	-	P51	G16	P67	-
I/O	-	P52	E18	P68	247
I/O	-	P53	F18	P69	250
I/O	P38	P54	G17	P70	253
I/O	P39	P55	G18	P71	256
I/O	-	-	H16	P72	259
I/O	-	-	H17	P73	262
I/O	-	P56	H18	P74	265
I/O	-	P57	J18	P75	268
I/O	P40	P58	J17	P76	271
I/O (INIT)	P41	P59	J16	P77	274
VCC	P42	P60	J15	P78	-
GND	P43	P61	K15	P79	-
I/O	P44	P62	K16	P80	277
I/O	P45	P63	K17	P81	280
I/O	-	P64	K18	P82	283
I/O	-	P65	L18	P83	286
I/O	-	-	L17	P84	289
I/O	-	-	L16	P85	292
I/O	P46	P66	M18	P86	295
I/O	P47	P67	M17	P87	298
I/O	-	P68	N18	P88	301
I/O	-	P69	P18	P89	304
GND	-	P70	M16	P90	-
I/O	-	P71	T18	P93	307
I/O	-	P72	P17	P94	310
I/O	P48	P73	N16	P95	313
I/O	P49	P74	T17	P96	316
I/O	-	P75	R17	P97	319
I/O	-	P76	P16	P98	322
I/O	P50	P77	U18	P99	325
I/O, SGCK3	P51	P78	T16	P100	328
GND	P52	P79	R16	P101	-
DONE	P53	P80	U17	P103	-
VCC	P54	P81	R15	P106	-
PROGRAM	P55	P82	V18	P108	-
I/O (D7)	P56	P83	T15	P109	331
I/O, PGCK3	P57	P84	U16	P110	334
I/O	-	P85	T14	P111	337
I/O	-	P86	U15	P112	340
I/O (D6)	P58	P87	V17	P113	343
I/O	-	P88	V16	P114	346
I/O	-	P89	T13	P115	349
I/O	-	P90	U14	P116	352
GND	-	P91	T12	P119	-
I/O	-	P92	U13	P120	355
I/O	-	P93	V13	P121	358
I/O (D5)	P59	P94	U12	P122	361
I/O (CS0)	P60	P95	V12	P123	364
I/O	-	-	T11	P124	367
I/O	-	-	U11	P125	370
I/O	-	P96	V11	P126	373
I/O	-	P97	V10	P127	376
I/O (D4)	P61	P98	U10	P128	379
I/O	P62	P99	T10	P129	382
VCC	P63	P100	R10	P130	-
GND	P64	P101	R9	P131	-
I/O (D3)	P65	P102	T9	P132	385
I/O (RS)	P66	P103	U9	P133	388
I/O	-	P104	V9	P134	391
I/O	-	P105	V8	P135	394
I/O	-	-	U8	P136	397

XC4008E Pad Name	PC84	PQ160	PG191	PQ208	Bndry Scan
I/O	-	-	T8	P137	400
I/O (D2)	P67	P106	V7	P138	403
I/O	P68	P107	U7	P139	406
I/O	-	P108	V6	P140	409
I/O	-	P109	U6	P141	412
GND	-	P110	T7	P142	-
I/O	-	P111	U5	P145	415
I/O	-	P112	T6	P146	418
I/O (D1)	P69	P113	V3	P147	421
I/O (RCLK, RDY/BUSY)	P70	P114	V2	P148	424
I/O	-	P115	U4	P149	427
I/O	-	P116	T5	P150	430
I/O (D0, DIN)	P71	P117	U3	P151	433
I/O, SGCK4 (DOUT)	P72	P118	T4	P152	436
CCLK	P73	P119	V1	P153	-
VCC	P74	P120	R4	P154	-
O, TDO	P75	P121	U2	P159	0
GND	P76	P122	R3	P160	-
I/O (A0, WS)	P77	P123	T3	P161	2
I/O, PGCK4 (A1)	P78	P124	U1	P162	5
I/O	-	P125	P3	P163	8
I/O	-	P126	R2	P164	11
I/O (CS1, A2)	P79	P127	T2	P165	14
I/O (A3)	P80	P128	N3	P166	17
I/O	-	P129	P2	P167	20
I/O	-	P130	T1	P168	23
GND	-	P131	M3	P171	-
I/O	-	P132	P1	P172	26
I/O	-	P133	N1	P173	29
I/O (A4)	P81	P134	M2	P174	32
I/O (A5)	P82	P135	M1	P175	35

XC4008E Pad Name	PC84	PQ160	PG191	PQ208	Bndry Scan
I/O	-	-	L3	P176	38
I/O	-	P136	L2	P177	41
I/O	-	P137	L1	P178	44
I/O	-	P138	K1	P179	47
I/O (A6)	P83	P139	K2	P180	50
I/O (A7)	P84	P140	K3	P181	53
GND	P1	P141	K4	P182	-

5/5/97

Additional XC4008E Package Pins

PG191

N.C. Pins					
A14	B5	B6	B13	D1	D18
F2	F17	N2	N17	R1	R18
V4	V5	V14	V15	-	-

6/3/97

PQ208

N.C. Pins					
P1	P3	P12	P13	P38	P39
P51	P52	P53	P54	P65	P66
P91	P92	P102	P104	P105	P107
P117	P118	P143	P144	P155	P156
P157	P158	P169	P170	P195	P196
P206	P207	P208	-	-	-

6/3/97

Pin Locations for XC4010E/XL Devices

The following table may contain pinout information for unsupported device/package combinations. Please see the availability charts elsewhere in the XC4000 Series data sheet for availability information.

XC4010E/XL Pad Name	PC 84	PQ 100††	TQ 144††	PQ 160	TQ 176††	PG 191†	PQ/HQ 208	BG 225†	BG 256††	Bndry Scan
VCC	P2	P92	P128	P142	P155	VCC*	P183	VCC*	VCC*	-
I/O (A8)	P3	P93	P129	P143	P156	J3	P184	E8	C10	62
I/O (A9)	P4	P94	P130	P144	P157	J2	P185	B7	D10	65
I/O (I9)	-	P95	P131	P145	P158	J1	P186	A7	A9	68
I/O (I18)	-	P96	P132	P146	P159	H1	P187	C7	B9	71
I/O	-	-	-	-	P160	H2	P188	D7	C9	74
I/O	-	-	-	-	P161	H3	P189	E7	D9	77
I/O (A10)	P5	P97	P133	P147	P162	G1	P190	A6	A8	80
I/O (A11)	P6	P98	P134	P148	P163	G2	P191	B6	B8	83
VCC	-	-	-	-	-	VCC*	-	VCC*	VCC*	-
I/O	-	-	P135	P149	P164	F1	P192	A5	B6	86
I/O	-	-	P136	P150	P165	E1	P193	B5	A5	89
GND	-	-	P137	P151	P166	GND*	P194	GND*	GND*	-
I/O	-	-	-	-	-	F2	P195	D6	C6	92
I/O	-	-	-	-	P167	D1	P196	C5	B5	95
I/O	-	-	-	P152	P168	C1	P197	A4	A4	98
I/O	-	-	-	P153	P169	E2	P198	E6	C5	101
I/O (A12)	P7	P99	P138	P154	P170	F3	P199	B4	B4	104
I/O (A13)	P8	P100	P139	P155	P171	D2	P200	D5	A3	107
I/O	-	-	P140	P156	P172	B1	P201	B3	B3	110
I/O	-	-	P141	P157	P173	E3	P202	F6	B2	113
I/O (A14)	P9	P1	P142	P158	P174	C2	P203	A2	A2	116
I/O, SGCK1 †, GCK8 †† (A15)	P10	P2	P143	P159	P175	B2	P204	C3	C3	119
VCC	P11	P3	P144	P160	P176	VCC*	P205	VCC*	VCC*	-
GND	P12	P4	P1	P1	P1	GND*	P2	GND*	GND*	-
I/O, PGCK1†, GCK1†† (A16)	P13	P5	P2	P2	P2	C3	P4	D4	B1	122
I/O (A17)	P14	P6	P3	P3	P3	C4	P5	B1	C2	125

XC4010E/XL Pad Name	PC 84	PQ 100††	TQ 144††	PQ 160	TQ 176††	PG 191†	PQ/HQ 208	BG 225†	BG 256††	Bndry Scan
I/O	-	-	P4	P4	P4	B3	P6	C2	D2	128
I/O	-	-	P5	P5	P5	C5	P7	E5	D3	131
I/O, TDI	P15	P7	P6	P6	P6	A2	P8	D3	E4	134
I/O, TCK	P16	P8	P7	P7	P7	B4	P9	C1	C1	137
I/O	-	-	-	P8	P8	C6	P10	D2	D1	140
I/O	-	-	-	P9	P9	A3	P11	G6	E3	143
I/O	-	-	-	-	-	B5	P12	E4	E2	146
I/O	-	-	-	-	-	B6	P13	D1	E1	149
GND	-	-	P8	P10	P10	GND*	P14	GND*	GND*	-
I/O	-	-	P9	P11	P11	A4	P15	F5	G3	152
I/O	-	-	P10	P12	P12	A5	P16	E1	G2	155
I/O, TMS	P17	P9	P11	P13	P13	B7	P17	F4	G1	158
I/O	P18	P10	P12	P14	P14	A6	P18	F3	H3	161
VCC	-	-	-	-	-	VCC*	-	VCC*	VCC*	-
I/O	-	-	-	-	P15	C8	P19	G4	J2	164
I/O	-	-	-	-	P16	A7	P20	G3	J1	167
I/O	-	-	P13	P15	P17	B8	P21	G2	K2	170
I/O	-	P11	P14	P16	P18	A8	P22	G1	K3	173
I/O	P19	P12	P15	P17	P19	B9	P23	G5	K1	176
I/O	P20	P13	P16	P18	P20	C9	P24	H3	L1	179
GND	P21	P14	P17	P19	P21	GND*	P25	GND*	GND*	-
VCC	P22	P15	P18	P20	P22	VCC*	P26	VCC*	VCC*	-
I/O	P23	P16	P19	P21	P23	C10	P27	H4	L2	182
I/O	P24	P17	P20	P22	P24	B10	P28	H5	L3	185
I/O	-	P18	P21	P23	P25	A9	P29	J2	L4	188
I/O	-	-	P22	P24	P26	A10	P30	J1	M1	191
I/O	-	-	-	-	P27	A11	P31	J3	M2	194
I/O	-	-	-	-	P28	C11	P32	J4	M3	197
VCC	-	-	-	-	-	VCC*	-	VCC*	VCC*	-
I/O	P25	P19	P23	P25	P29	B11	P33	K2	P1	200
I/O	P26	P20	P24	P26	P30	A12	P34	K3	P2	203

XC4010E/XL Pad Name	PC 84	PQ 100††	TQ 144††	PQ 160	TQ 176††	PG 191†	PQ/HQ 208	BG 225†	BG 256††	Bndry Scan
I/O	-	-	P25	P27	P31	B12	P35	J6	R1	206
I/O	-	-	P26	P28	P32	A13	P36	L1	P3	209
GND	-	-	P27	P29	P33	GND*	P37	GND*	GND*	-
I/O	-	-	-	-	-	B13	P38	L3	T2	212
I/O	-	-	-	-	-	A14	P39	M1	U1	215
I/O	-	-	-	P30	P34	A15	P40	K5	T3	218
I/O	-	-	-	P31	P35	C13	P41	M2	U2	221
I/O	P27	P21	P28	P32	P36	B14	P42	L4	V1	224
I/O	-	P22	P29	P33	P37	A16	P43	N1	T4	227
I/O	-	-	P30	P34	P38	B15	P44	M3	U3	230
I/O	-	-	P31	P35	P39	C14	P45	N2	V2	233
I/O	P28	P23	P32	P36	P40	A17	P46	K6	W1	236
I/O, SGCK2 †, GCK2 ††	P29	P24	P33	P37	P41	B16	P47	P1	V3	239
O (M1)	P30	P25	P34	P38	P42	C15	P48	N3	W2	242
GND	P31	P26	P35	P39	P43	GND*	P49	GND*	GND*	-
I (M0)	P32	P27	P36	P40	P44	A18	P50	P2	Y1	245
VCC	P33	P28	P37	P41	P45	VCC*	P55	VCC*	VCC*	-
I (M2)	P34	P29	P38	P42	P46	C16	P56	M4	W3	246
I/O, PGCK2 †, GCK3 ††	P35	P30	P39	P43	P47	B17	P57	R2	Y2	247
I/O (HDC)	P36	P31	P40	P44	P48	E16	P58	P3	W4	250
I/O	-	-	P41	P45	P49	C17	P59	L5	V4	253
I/O	-	-	P42	P46	P50	D17	P60	N4	U5	256
I/O	-	P32	P43	P47	P51	B18	P61	R3	Y3	259
I/O (LDC)	P37	P33	P44	P48	P52	E17	P62	P4	Y4	262
I/O	-	-	-	P49	P53	F16	P63	K7	V5	265
I/O	-	-	-	P50	P54	C18	P64	M5	W5	268
I/O	-	-	-	-	-	D18	P65	R4	Y5	271
I/O	-	-	-	-	-	F17	P66	N5	V6	274
GND	-	-	P45	P51	P55	GND*	P67	GND*	GND*	-
I/O	-	-	P46	P52	P56	E18	P68	R5	W7	277
I/O	-	-	P47	P53	P57	F18	P69	M6	Y7	280
I/O	P38	P34	P48	P54	P58	G17	P70	N6	V8	283
I/O	P39	P35	P49	P55	P59	G18	P71	P6	W8	286
VCC	-	-	-	-	-	VCC*	-	VCC*	VCC*	-
I/O	-	-	-	-	P60	H16	P72	R6	Y8	289
I/O	-	-	-	-	P61	H17	P73	M7	U9	292
I/O	-	P36	P50	P56	P62	H18	P74	R7	V10	295
I/O	-	P37	P51	P57	P63	J18	P75	L7	Y10	298
I/O	P40	P38	P52	P58	P64	J17	P76	N8	Y11	301
I/O (INIT)	P41	P39	P53	P59	P65	J16	P77	P8	W11	304
VCC	P42	P40	P54	P60	P66	VCC*	P78	VCC*	VCC*	-
GND	P43	P41	P55	P61	P67	GND*	P79	GND*	GND*	-
I/O	P44	P42	P56	P62	P68	K16	P80	L8	V11	307
I/O	P45	P43	P57	P63	P69	K17	P81	P9	U11	310
I/O	-	P44	P58	P64	P70	K18	P82	R9	Y12	313
I/O	-	P45	P59	P65	P71	L18	P83	N9	W12	316
I/O	-	-	-	-	P72	L17	P84	M9	V12	319
I/O	-	-	-	-	P73	L16	P85	L9	U12	322
VCC	-	-	-	-	-	VCC*	-	VCC*	VCC*	-
I/O	P46	P46	P60	P66	P74	M18	P86	N10	Y15	325
I/O	P47	P47	P61	P67	P75	M17	P87	K9	V14	328
I/O	-	-	P62	P68	P76	N18	P88	R11	W15	331
I/O	-	-	P63	P69	P77	P18	P89	P11	Y16	334
GND	-	-	P64	P70	P78	GND*	P90	GND*	GND*	-
I/O	-	-	-	-	-	N17	P91	R12	Y17	337
I/O	-	-	-	-	-	R18	P92	L10	V16	340
I/O	-	-	-	P71	P79	T18	P93	P12	W17	343
I/O	-	-	-	P72	P80	P17	P94	M11	Y18	346
I/O	P48	P48	P65	P73	P81	N16	P95	R13	U16	349
I/O	P49	P49	P66	P74	P82	T17	P96	N12	V17	352
I/O	-	-	P67	P75	P83	R17	P97	P13	W18	355
I/O	-	-	P68	P76	P84	P16	P98	K10	Y19	358
I/O	P50	P50	P69	P77	P85	U18	P99	R14	V18	361
I/O, SGCK3 †, GCK4 ††	P51	P51	P70	P78	P86	T16	P100	N13	W19	364
GND	P52	P52	P71	P79	P87	GND*	P101	GND*	GND*	-
DONE	P53	P53	P72	P80	P88	U17	P103	P14	Y20	-
VCC	P54	P54	P73	P81	P89	VCC*	P106	VCC*	VCC*	-
PROGRAM	P55	P55	P74	P82	P90	V18	P108	M12	V19	-
I/O (D7)	P56	P56	P75	P83	P91	T15	P109	P15	U19	367
I/O, PGCK3 †, GCK5 ††	P57	P57	P76	P84	P92	U16	P110	N14	U18	370

XC4010E/XL Pad Name	PC 84	PQ 100††	TQ 144††	PQ 160	TQ 176††	PG 191†	PQ/HQ 208	BG 225†	BG 256††	Bndry Scan
I/O	-	-	P77	P85	P93	T14	P111	L11	T17	373
I/O	-	-	P78	P86	P94	U15	P112	M13	V20	376
I/O (D6)	P58	P58	P79	P87	P95	V17	P113	J10	T19	379
I/O	-	P59	P80	P88	P96	V16	P114	L12	T20	382
I/O	-	-	-	P89	P97	T13	P115	M15	R18	385
I/O	-	-	-	P90	P98	U14	P116	L13	R19	388
I/O	-	-	-	-	-	V15	P117	L14	R20	391
I/O	-	-	-	-	-	V14	P118	K11	P18	394
GND	-	-	P81	P91	P99	GND*	P119	GND*	GND*	-
I/O	-	-	P82	P92	P100	U13	P120	K13	N19	397
I/O	-	-	P83	P93	P101	V13	P121	K14	N20	400
VCC	-	-	-	-	-	VCC*	-	VCC*	VCC*	-
I/O (D5)	P59	P60	P84	P94	P102	U12	P122	K15	M17	403
I/O (CS0)	P60	P61	P85	P95	P103	V12	P123	J12	M18	406
I/O	-	-	-	-	P104	T11	P124	J13	M20	409
I/O	-	-	-	-	P105	U11	P125	J14	L19	412
I/O	-	P62	P86	P96	P106	V11	P126	J15	L18	415
I/O	-	P63	P87	P97	P107	V10	P127	J11	L20	418
I/O (D4)	P61	P64	P88	P98	P108	U10	P128	H13	K20	421
I/O	P62	P65	P89	P99	P109	T10	P129	H14	K19	424
VCC	P63	P66	P90	P100	P110	VCC*	P130	VCC*	VCC*	-
GND	P64	P67	P91	P101	P111	GND*	P131	GND*	GND*	-
I/O (D3)	P65	P68	P92	P102	P112	T9	P132	H12	K18	427
I/O (RS)	P66	P69	P93	P103	P113	U9	P133	H11	K17	430
I/O	-	P70	P94	P104	P114	V9	P134	G14	J20	433
I/O	-	-	P95	P105	P115	V8	P135	G15	J19	436
I/O	-	-	-	-	P116	U8	P136	G13	J18	439
I/O	-	-	-	-	P117	T8	P137	G12	J17	442
I/O (D2)	P67	P71	P96	P106	P118	V7	P138	G11	H19	445
I/O	P68	P72	P97	P107	P119	U7	P139	F15	H18	448
VCC	-	-	-	-	-	VCC*	-	VCC*	VCC*	-
I/O	-	-	P98	P108	P120	V6	P140	F14	G19	451
I/O	-	-	P99	P109	P121	U6	P141	F13	F20	454
GND	-	-	P100	P110	P122	GND*	P142	GND*	GND*	-
I/O	-	-	-	-	-	V5	P143	E13	D20	457
I/O	-	-	-	-	-	V4	P144	D15	E18	460
I/O	-	-	-	P111	P123	U5	P145	F11	D19	463
I/O	-	-	-	P112	P124	T6	P146	D14	C20	466
I/O (D1)	P69	P73	P101	P113	P125	V3	P147	E12	E17	469
I/O (RCLK, RDY/BUSY)	P70	P74	P102	P114	P126	V2	P148	C15	D18	472
I/O	-	-	P103	P115	P127	U4	P149	D13	C19	475
I/O	-	-	P104	P116	P128	T5	P150	C14	B20	478
I/O (D0, DIN)	P71	P75	P105	P117	P129	U3	P151	F10	C18	481
I/O, SGCK4 †, GCK6 †† (DOUT)	P72	P76	P106	P118	P130	T4	P152	B15	B19	484
CCLK	P73	P77	P107	P119	P131	V1	P153	C13	A20	-
VCC	P74	P78	P108	P120	P132	VCC*	P154	VCC*	VCC*	-
O, TDO	P75	P79	P109	P121	P133	U2	P159	A15	A19	0
GND	P76	P80	P110	P122	P134	GND*	P160	GND*	GND*	-
I/O (A0, WS)	P77	P81	P111	P123	P135	T3	P161	A14	B18	2
I/O, PGCK4 †, GCK7 †† (A1)	P78	P82	P112	P124	P136	U1	P162	B13	B17	5
I/O	-	-	P113	P125	P137	P3	P163	E11	C17	8
I/O	-	-	P114	P126	P138	R2	P164	C12	D16	11
I/O (CS1, A2)	P79	P83	P115	P127	P139	T2	P165	A13	A18	14
I/O (A3)	P80	P84	P116	P128	P140	N3	P166	B12	A17	17
I/O	-	-	P117	P129	P141	P2	P167	A12	A16	20
I/O	-	-	-	P130	P142	T1	P168	C11	C15	23
I/O	-	-	-	-	-	R1	P169	B11	B15	26
I/O	-	-	-	-	-	N2	P170	E10	A15	29
GND	-	-	P118	P131	P143	GND*	P171	GND*	GND*	-
I/O	-	-	P119	P132	P144	P1	P172	A11	B14	32
I/O	-	-	P120	P133	P145	N1	P173	D10	A14	35
VCC	-	-	-	-	-	VCC*	-	VCC*	VCC*	-
I/O (A4)	P81	P85	P121	P134	P146	M2	P174	A10	C12	38
I/O (A5)	P82	P86	P122	P135	P147	M1	P175	D9	B12	41
I/O	-	-	-	-	P148	L3	P176	C9	A12	44
I/O	-	-	-	P136	P149	L2	P177	B9	B11	47
I/O (A21)††	-	P87	P123	P137	P150	L1	P178	A9	C11	50
I/O (A20)††	-	P88	P124	P138	P151	K1	P179	E9	A11	53
I/O (A6)	P83	P89	P125	P139	P152	K2	P180	C8	A10	56
I/O (A7)	P84	P90	P126	P140	P153	K3	P181	B8	B10	59

XC4010E/XL Pad Name	PC 84	PQ 100††	TQ 144††	PQ 160	TQ 176††	PG 191†	PQ/HQ 208	BG 225†	BG 256††	Bndry Scan
GND	P1	P91	P127	P141	P154	GND*	P182	GND*	GND*	-

6/19/97

* Pads labelled GND* or VCC* are internally bonded to Ground or VCC planes within the package. They have no direct connection to any specific package pin.

† = E only

†† = XL only

Additional XC4010E/XL Package Pins

PQ/HQ208

N.C. Pins						
P1	P3	P51	P52	P53	P54	P102
P104	P105	P107	P155	P156	P157	P158
P206	P207	P208	-	-	-	-

5/27/97

PG191

VCC Pins						
D3	D10	D16	J4	J15	R4	R10
R15	-	-	-	-	-	-
GND Pins						
C7	C12	D4	D9	D15	G3	G16
K4	K15	M3	M16	R3	R9	R16
T7	T12	-	-	-	-	-

5/27/97

BG225

VCC Pins						
B2	B14	D8	H1	H15	R1	R8
R15	-	-	-	-	-	-
GND Pins						
A1	A8	D12	F8	G7	G8	G9
H2	H6	H7	H8	H9	H10	J7
J8	J9	K8	M8	-	-	-
N.C. Pins						
A3	B10	C4	C6	C10	D11	E2
E3	E14	E15	F1	F2	F7	F9
F12	G10	J5	K1	K4	K12	L2
L6	L15	M10	M14	N7	N11	N15
P5	P7	P10	R10	-	-	-

6/16/97

BG256

VCC Pins						
C14	D6	D7	D11	D14	D15	E20
F1	F4	F17	G4	G17	K4	L17
P4	P17	P19	R2	R4	R17	U6
U7	U10	U14	U15	V7	W20	-
GND Pins						
A1	B7	D4	D8	D13	D17	G20
H4	H17	N3	N4	N17	U4	U8
U13	U17	W14	-	-	-	-
N.C. Pins						
A6	A7	A13	B13	B16	C4	C7
C8	C13	C16	D5	D12	E19	F2
F3	F18	F19	G18	H1	H2	H20
J3	J4	M4	M19	N1	N2	N18
P20	R3	T1	T18	U20	V9	V13
V15	W6	W9	W10	W13	W16	Y6
Y9	Y13	Y14	-	-	-	-

5/27/97

Pin Locations for XC4013E/XL Devices

The following table may contain pinout information for unsupported device/package combinations. Please see the availability charts elsewhere in the XC4000 Series data sheet for availability information.

XC4013E /XL Pad Name	HT 144††	PQ 160	HT 176††	PQ/HQ 208	PG 223†	BG 225†	PQ/HQ 240	BG 256††	Bndry Scan
VCC	P128	P142	P155	P183	VCC*	VCC*	P212	VCC*	-
I/O (A8)	P129	P143	P156	P184	J3	E8	P213	C10	74
I/O (A9)	P130	P144	P157	P185	J2	B7	P214	D10	77
I/O (A19) ††	P131	P145	P158	P186	J1	A7	P215	A9	80
I/O (A18) ††	P132	P146	P159	P187	H1	C7	P216	B9	83
I/O	-	-	P160	P188	H2	D7	P217	C9	86
I/O	-	-	P161	P189	H3	E7	P218	D9	89
I/O (A10)	P133	P147	P162	P190	G1	A6	P220	A8	92
I/O (A11)	P134	P148	P163	P191	G2	B6	P221	B8	95
VCC	-	-	-	-	VCC*	VCC*	P222	VCC*	-
I/O	-	-	-	-	H4	C6	P223	A6	98
I/O	-	-	-	-	G4	F7	P224	C7	101
I/O	P135	P149	P164	P192	F1	A5	P225	B6	104
I/O	P136	P150	P165	P193	E1	B5	P226	A5	107
GND	P137	P151	P166	P194	GND*	GND*	P227	GND*	-
I/O	-	-	-	P195	F2	D6	P228	C6	110
I/O	-	-	P167	P196	D1	C5	P229	B5	113
I/O	-	P152	P168	P197	C1	A4	P230	A4	116
I/O	-	P153	P169	P198	E2	E6	P231	C5	119
I/O (A12)	P138	P154	P170	P199	F3	B4	P232	B4	122
I/O (A13)	P139	P155	P171	P200	D2	D5	P233	A3	125
I/O	-	-	-	-	F4	A3	P234	D5	128
I/O	-	-	-	-	E4	C4	P235	C4	131
I/O	P140	P156	P172	P201	B1	B3	P236	B3	134
I/O	P141	P157	P173	P202	E3	F6	P237	B2	137

XC4013E /XL Pad Name	HT 144††	PQ 160	HT 176††	PQ/HQ 208	PG 223†	BG 225†	PQ/HQ 240	BG 256††	Bndry Scan
I/O (A14)	P142	P158	P174	P203	C2	A2	P238	A2	140
I/O, SGCK1 †, GCK8 †† (A15)	P143	P159	P175	P204	B2	C3	P239	C3	143
VCC	P144	P160	P176	P205	VCC*	VCC*	P240	VCC*	-
GND	P1	P1	P1	P2	GND*	GND*	P1	GND*	-
I/O, PGCK1 †, GCK1 †† (A16)	P2	P2	P2	P4	C3	D4	P2	B1	146
I/O (A17)	P3	P3	P3	P5	C4	B1	P3	C2	149
I/O	P4	P4	P4	P6	B3	C2	P4	D2	152
I/O	P5	P5	P5	P7	C5	E5	P5	D3	155
I/O, TDI	P6	P6	P6	P8	A2	D3	P6	E4	158
I/O, TCK	P7	P7	P7	P9	B4	C1	P7	C1	161
I/O	-	P8	P8	P10	C6	D2	P8	D1	164
I/O	-	P9	P9	P11	A3	G6	P9	E3	167
I/O	-	-	-	P12	B5	E4	P10	E2	170
I/O	-	-	-	P13	B6	D1	P11	E1	173
I/O	-	-	-	-	D5	E3	P12	F3	176
I/O	-	-	-	-	D6	E2	P13	F2	179
GND	P8	P10	P10	P14	GND*	GND*	P14	GND*	-
I/O	P9	P11	P11	P15	A4	F5	P15	G3	182
I/O	P10	P12	P12	P16	A5	E1	P16	G2	185
I/O, TMS	P11	P13	P13	P17	B7	F4	P17	G1	188
I/O	P12	P14	P14	P18	A6	F3	P18	H3	191
VCC	-	-	-	-	VCC*	VCC*	P19	VCC*	-

XC4013E /XL Pad Name	HT 144††	PQ 160	HT 176††	PQ/HQ 208	PG 223†	BG 225†	PQ/ HQ 240	BG 256††	Bndry Scan
I/O	-	-	-	-	D7	F2	P20	H2	194
I/O	-	-	-	-	D8	F1	P21	H1	197
I/O	-	-	P15	P19	C8	G4	P23	J2	200
I/O	-	-	P16	P20	A7	G3	P24	J1	203
I/O	P13	P15	P17	P21	B8	G2	P25	K2	206
I/O	P14	P16	P18	P22	A8	G1	P26	K3	209
I/O	P15	P17	P19	P23	B9	G5	P27	K1	212
I/O	P16	P18	P20	P24	C9	H3	P28	L1	215
GND	P17	P19	P21	P25	GND*	GND*	P29	GND*	-
VCC	P18	P20	P22	P26	VCC*	VCC*	P30	VCC*	-
I/O	P19	P21	P23	P27	C10	H4	P31	L2	218
I/O	P20	P22	P24	P28	B10	H5	P32	L3	221
I/O	P21	P23	P25	P29	A9	J2	P33	L4	224
I/O	P22	P24	P26	P30	A10	J1	P34	M1	227
I/O	-	-	P27	P31	A11	J3	P35	M2	230
I/O	-	-	P28	P32	C11	J4	P36	M3	233
I/O	-	-	-	-	D11	J5	P38	N1	236
I/O	-	-	-	-	D12	K1	P39	N2	239
VCC	-	-	-	-	VCC*	VCC*	P40	VCC*	-
I/O	P23	P25	P29	P33	B11	K2	P41	P1	242
I/O	P24	P26	P30	P34	A12	K3	P42	P2	245
I/O	P25	P27	P31	P35	B12	J6	P43	R1	248
I/O	P26	P28	P32	P36	A13	L1	P44	P3	251
GND	P27	P29	P33	P37	GND*	GND*	P45	GND*	-
I/O	-	-	-	-	D13	L2	P46	T1	254
I/O	-	-	-	-	D14	K4	P47	R3	257
I/O	-	-	-	P38	B13	L3	P48	T2	260
I/O	-	-	-	P39	A14	M1	P49	U1	263
I/O	-	P30	P34	P40	A15	K5	P50	T3	266
I/O	-	P31	P35	P41	C13	M2	P51	U2	269
I/O	P28	P32	P36	P42	B14	L4	P52	V1	272
I/O	P29	P33	P37	P43	A16	N1	P53	T4	275
I/O	P30	P34	P38	P44	B15	M3	P54	U3	278
I/O	P31	P35	P39	P45	C14	N2	P55	V2	281
I/O	P32	P36	P40	P46	A17	K6	P56	W1	284
I/O, SGCK2 †, GCK2 ††	P33	P37	P41	P47	B16	P1	P57	V3	287
O (M1)	P34	P38	P42	P48	C15	N3	P58	W2	290
GND	P35	P39	P43	P49	GND*	GND*	P59	GND*	-
I (M0)	P36	P40	P44	P50	A18	P2	P60	Y1	293
VCC	P37	P41	P45	P55	VCC*	VCC*	P61	VCC*	-
I (M2)	P38	P42	P46	P56	C16	M4	P62	W3	294
I/O, PGCK2 †, GCK3 ††	P39	P43	P47	P57	B17	R2	P63	Y2	295
I/O (HDC)	P40	P44	P48	P58	E16	P3	P64	W4	298
I/O	P41	P45	P49	P59	C17	L5	P65	V4	301
I/O	P42	P46	P50	P60	D17	N4	P66	U5	304
I/O	P43	P47	P51	P61	B18	R3	P67	Y3	307
I/O (LDC)	P44	P48	P52	P62	E17	P4	P68	Y4	310
I/O	-	P49	P53	P63	F16	K7	P69	V5	313
I/O	-	P50	P54	P64	C18	M5	P70	W5	316
I/O	-	-	-	P65	D18	R4	P71	Y5	319
I/O	-	-	-	P66	F17	N5	P72	V6	322
I/O	-	-	-	-	E15	P5	P73	W6	325
I/O	-	-	-	-	F15	L6	P74	Y6	328
GND	P45	P51	P55	P67	GND*	GND*	P75	GND*	-
I/O	P46	P52	P56	P68	E18	R5	P76	W7	331
I/O	P47	P53	P57	P69	F18	M6	P77	Y7	334
I/O	P48	P54	P58	P70	G17	N6	P78	V8	337
I/O	P49	P55	P59	P71	G18	P6	P79	W8	340
VCC	-	-	-	-	VCC*	VCC*	P80	VCC*	-
I/O	-	-	P60	P72	H16	R6	P81	Y8	343
I/O	-	-	P61	P73	H17	M7	P82	U9	346
I/O	-	-	-	-	G15	N7	P84	Y9	349
I/O	-	-	-	-	H15	P7	P85	W10	352
I/O	P50	P56	P62	P74	H18	R7	P86	V10	355
I/O	P51	P57	P63	P75	J18	L7	P87	Y10	358
I/O	P52	P58	P64	P76	J17	N8	P88	Y11	361
I/O (INIT)	P53	P59	P65	P77	J16	P8	P89	W11	364
VCC	P54	P60	P66	P78	VCC*	VCC*	P90	VCC*	-
GND	P55	P61	P67	P79	GND*	GND*	P91	GND*	-
I/O	P56	P62	P68	P80	K16	L8	P92	V11	367

XC4013E /XL Pad Name	HT 144††	PQ 160	HT 176††	PQ/HQ 208	PG 223†	BG 225†	PQ/ HQ 240	BG 256††	Bndry Scan
I/O	P57	P63	P69	P81	K17	P9	P93	U11	370
I/O	P58	P64	P70	P82	K18	R9	P94	Y12	373
I/O	P59	P65	P71	P83	L18	N9	P95	W12	376
I/O	-	-	P72	P84	L17	M9	P96	V12	379
I/O	-	-	P73	P85	L16	L9	P97	U12	382
I/O	-	-	-	-	L15	R10	P99	V13	385
I/O	-	-	-	-	M15	P10	P100	Y14	388
VCC	-	-	-	-	VCC*	VCC*	P101	VCC*	-
I/O	P60	P66	P74	P86	M18	N10	P102	Y15	391
I/O	P61	P67	P75	P87	M17	K9	P103	V14	394
I/O	P62	P68	P76	P88	N18	R11	P104	W15	397
I/O	P63	P69	P77	P89	P18	P11	P105	Y16	400
GND	P64	P70	P78	P90	GND*	GND*	P106	GND*	-
I/O	-	-	-	-	N15	M10	P107	V15	403
I/O	-	-	-	-	P15	N11	P108	W16	406
I/O	-	-	-	P91	R17	R12	P109	Y17	409
I/O	-	-	-	P92	R18	L10	P110	V16	412
I/O	-	P71	P79	P93	T18	P12	P111	W17	415
I/O	-	P72	P80	P94	P17	M11	P112	Y18	418
I/O	P65	P73	P81	P95	N16	R13	P113	U16	421
I/O	P66	P74	P82	P96	T17	N12	P114	V17	424
I/O	P67	P75	P83	P97	R17	P13	P115	W18	427
I/O	P68	P76	P84	P98	P16	K10	P116	Y19	430
I/O	P69	P77	P85	P99	U18	R14	P117	V18	433
I/O, SGCK3 †, GCK4 ††	P70	P78	P86	P100	T16	N13	P118	W19	436
GND	P71	P79	P87	P101	GND*	GND*	P119	GND*	-
DONE	P72	P80	P88	P103	U17	P14	P120	Y20	-
VCC	P73	P81	P89	P106	VCC*	VCC*	P121	VCC*	-
PRO- GRAM	P74	P82	P90	P108	V18	M12	P122	V19	-
I/O (D7)	P75	P83	P91	P109	T15	P15	P123	U19	439
I/O, PGCK3 †, GCK5 ††	P76	P84	P92	P110	U16	N14	P124	U18	442
I/O	P77	P85	P93	P111	T14	L11	P125	T17	445
I/O	P78	P86	P94	P112	U15	M13	P126	V20	448
I/O	-	-	-	-	R14	N15	P127	U20	451
I/O	-	-	-	-	R13	M14	P128	T18	454
I/O (D6)	P79	P87	P95	P113	V17	J10	P129	T19	457
I/O	P80	P88	P96	P114	V16	L12	P130	T20	460
I/O	-	P89	P97	P115	T13	M15	P131	R18	463
I/O	-	P90	P98	P116	U14	L13	P132	R19	466
I/O	-	-	-	P117	V15	L14	P133	R20	469
I/O	-	-	-	P118	V14	K11	P134	P18	472
GND	P81	P91	P99	P119	GND*	GND*	P135	GND*	-
I/O	-	-	-	-	R12	L15	P136	P20	475
I/O	-	-	-	-	R11	K12	P137	N18	478
I/O	P82	P92	P100	P120	U13	K13	P138	N19	481
I/O	P83	P93	P101	P121	V13	K14	P139	N20	484
VCC	-	-	-	-	VCC*	VCC*	P140	VCC*	-
I/O (D5)	P84	P94	P102	P122	U12	K15	P141	M17	487
I/O (CS0)	P85	P95	P103	P123	V12	J12	P142	M18	490
I/O	-	-	P104	P124	T11	J13	P144	M20	493
I/O	-	-	P105	P125	U11	J14	P145	L19	496
I/O	P86	P96	P106	P126	V11	J15	P146	L18	499
I/O	P87	P97	P107	P127	V10	J11	P147	L20	502
I/O (D4)	P88	P98	P108	P128	U10	H13	P148	K20	505
I/O	P89	P99	P109	P129	T10	H14	P149	K19	508
VCC	P90	P100	P110	P130	VCC*	VCC*	P150	VCC*	-
GND	P91	P101	P111	P131	GND*	GND*	P151	GND*	-
I/O (D3)	P92	P102	P112	P132	T9	H12	P152	K18	511
I/O (RS)	P93	P103	P113	P133	U9	H11	P153	K17	514
I/O	P94	P104	P114	P134	V9	G14	P154	J20	517
I/O	P95	P105	P115	P135	V8	G15	P155	J19	520
I/O	-	-	P116	P136	U8	G13	P156	J18	523
I/O	-	-	P117	P137	T8	G12	P157	J17	526
I/O (D2)	P96	P106	P118	P138	V7	G11	P159	H19	529
I/O	P97	P107	P119	P139	U7	F15	P160	H18	532
VCC	-	-	-	-	VCC*	VCC*	P161	VCC*	-
I/O	P98	P108	P120	P140	V6	F14	P162	G19	535
I/O	P99	P109	P121	P141	U6	F13	P163	F20	538
I/O	-	-	-	-	R8	G10	P164	G18	541

XC4013E /XL Pad Name	HT 144††	PQ 160	HT 176††	PQ/HQ 208	PG 223†	BG 225†	PQ/HQ 240	BG 256††	Bdry Scan
I/O	-	-	-	-	R7	E15	P165	F19	544
GND	P100	P110	P122	P142	GND*	GND*	P166	GND*	-
I/O	-	-	-	-	R6	E14	P167	F18	547
I/O	-	-	-	-	R5	F12	P168	E19	550
I/O	-	-	-	P143	V5	E13	P169	D20	553
I/O	-	-	-	P144	V4	D15	P170	E18	556
I/O	-	P111	P123	P145	U5	F11	P171	D19	559
I/O	-	P112	P124	P146	T6	D14	P172	C20	562
I/O (D1)	P101	P113	P125	P147	V3	E12	P173	E17	565
I/O (RCLK, RDY/ BUSY)	P102	P114	P126	P148	V2	C15	P174	D18	568
I/O	P103	P115	P127	P149	U4	D13	P175	C19	571
I/O	P104	P116	P128	P150	T5	C14	P176	B20	574
I/O (D0, DIN)	P105	P117	P129	P151	U3	F10	P177	C18	577
I/O, SGCK4 †, GCK6 †† (DOUT)	P106	P118	P130	P152	T4	B15	P178	B19	580
CCLK	P107	P119	P131	P153	V1	C13	P179	A20	-
VCC	P108	P120	P132	P154	VCC*	VCC*	P180	VCC*	-
O, TDO	P109	P121	P133	P159	U2	A15	P181	A19	0
GND	P110	P122	P134	P160	GND*	GND*	P182	GND*	-
I/O (A0, WS)	P111	P123	P135	P161	T3	A14	P183	B18	2
I/O, PGCK4 †, GCK7 †† (A1)	P112	P124	P136	P162	U1	B13	P184	B17	5
I/O	P113	P125	P137	P163	P3	E11	P185	C17	8
I/O	P114	P126	P138	P164	R2	C12	P186	D16	11
I/O (CS1, A2)	P115	P127	P139	P165	T2	A13	P187	A18	14
I/O (A3)	P116	P128	P140	P166	N3	B12	P188	A17	17
I/O	-	-	-	-	P4	F9	P189	C16	20
I/O	-	-	-	-	N4	D11	P190	B16	23
I/O	P117	P129	P141	P167	P2	A12	P191	A16	26
I/O	-	P130	P142	P168	T1	C11	P192	C15	29
I/O	-	-	-	P169	R1	B11	P193	B15	32
I/O	-	-	-	P170	N2	E10	P194	A15	35
GND	P118	P131	P143	P171	GND*	GND*	P196	GND*	-
I/O	P119	P132	P144	P172	P1	A11	P197	B14	38
I/O	P120	P133	P145	P173	N1	D10	P198	A14	41
I/O	-	-	-	-	M4	C10	P199	C13	44
I/O	-	-	-	-	L4	B10	P200	B13	47
VCC	-	-	-	-	VCC*	VCC*	P201	VCC*	-
I/O (A4)	P121	P134	P146	P174	M2	A10	P202	C12	50
I/O (A5)	P122	P135	P147	P175	M1	D9	P203	B12	53
I/O	-	-	P148	P176	L3	C9	P205	A12	56
I/O	-	P136	P149	P177	L2	B9	P206	B11	59
I/O (A21) ††	P123	P137	P150	P178	L1	A9	P207	C11	62
I/O (A20) ††	P124	P138	P151	P179	K1	E9	P208	A11	65
I/O (A6)	P125	P139	P152	P180	K2	C8	P209	A10	68
I/O (A7)	P126	P140	P153	P181	K3	B8	P210	B10	71
GND	P127	P141	P154	P182	GND*	GND*	P211	GND*	-

6/9/97

* Pads labelled GND* or VCC* are internally bonded to Ground or VCC planes within the package. They have no direct connection to any specific package pin.

† = E only, †† = XL only

Additional XC4013E/XL Package Pins

PQ/HQ208

N.C. Pins					
P1	P3	P51	P52	P53	P54
P102	P104	P105	P107	P155	P156
P157	P158	P206	P207	P208	-

5/5/97

BG223

VCC Pins					
D3	D10	D16	J4	J15	R4
R10	R15	-	-	-	-
GND Pins					
C7	C12	D4	D9	D15	G3
G16	K4	K15	M3	M16	R3
R9	R16	T7	T12	-	-

5/5/97

BG225

VCC Pins				
B2	B14	D8	H1	H15
R1	R8	R15	-	-
GND Pins				
A1	A8	D12	F8	G7
G8	G9	H2	H6	H7
H8	H9	H10	J7	J8
J9	K8	M8	-	-

5/5/97

The BG225 package pins in this table are bonded to an internal Ground plane on the XC4013E die. They must all be externally connected to Ground.

PQ/HQ240

GND Pins					
P22‡	P37‡	P83‡	P98‡	P143‡	P158‡
P204‡	P219‡	-	-	-	-
N.C. Pins					
P195	-	-	-	-	-

6/9/97

‡ Pins marked with this symbol are used for Ground connections on some revisions of the device. These pins may not physically connect to anything on the current device revision. However, they should be externally connected to Ground, if possible.

BG256

VCC Pins					
C14	D6	D7	D11	D14	D15
E20	F1	F4	F17	G4	G17
K4	L17	P4	P17	P19	R2
R4	R17	U6	U7	U10	U14
U15	V7	W20	-	-	-
GND Pins					
A1	B7	D4	D8	D13	D17
G20	H4	H17	N3	N4	N17
U4	U8	U13	U17	W14	-
N.C. Pins					
A7	A13	C8	D12	H20	J3
J4	M4	M19	V9	W9	W13
Y13	-	-	-	-	-

6/4/97

Pin Locations for XC4020E/XL Devices

The following table may contain pinout information for unsupported device/package combinations. Please see the availability charts elsewhere in the XC4000 Series data sheet for availability information.

XC4020E/XL Pad Name	HT 144††	PQ 160††	HT 176††	HQ208† PQ208††	PG 223†	HQ240† PQ240††	BG 256††	Bndry Scan
VCC	P128	P142	P155	P183	VCC*	P212	VCC*	-
I/O (A8)	P129	P143	P156	P184	J3	P213	C10	86
I/O (A9)	P130	P144	P157	P185	J2	P214	D10	89
I/O (A19) ††	P131	P145	P158	P186	J1	P215	A9	92
I/O (A18) ††	P132	P146	P159	P187	H1	P216	B9	95
I/O	-	-	P160	P188	H2	P217	C9	98
I/O	-	-	P161	P189	H3	P218	D9	101
I/O (A10)	P133	P147	P162	P190	G1	P220	A8	104
I/O (A11)	P134	P148	P163	P191	G2	P221	B8	107
I/O	-	-	-	-	-	-	C8	110
I/O	-	-	-	-	-	-	A7	113
VCC	-	-	-	-	VCC*	P222	VCC*	-
I/O	-	-	-	-	H4	P223	A6	116
I/O	-	-	-	-	G4	P224	C7	119
I/O	P135	P149	P164	P192	F1	P225	B6	122
I/O	P136	P150	P165	P193	E1	P226	A5	125
GND	P137	P151	P166	P194	GND*	P227	GND*	-
I/O	-	-	-	P195	F2	P228	C6	128
I/O	-	-	P167	P196	D1	P229	B5	131
I/O	-	P152	P168	P197	C1	P230	A4	134
I/O	-	P153	P169	P198	E2	P231	C5	137
I/O (A12)	P138	P154	P170	P199	F3	P232	B4	140
I/O (A13)	P139	P155	P171	P200	D2	P233	A3	143
I/O	-	-	-	-	F4	P234	D5	152
I/O	-	-	-	-	E4	P235	C4	155
I/O	P140	P156	P172	P201	B1	P236	B3	158
I/O	P141	P157	P173	P202	E3	P237	B2	161
I/O (A14)	P142	P158	P174	P203	C2	P238	A2	164
I/O, SGCK1 †, GCK8 †† (A15)	P143	P159	P175	P204	B2	P239	C3	167
VCC	P144	P160	P176	P205	VCC*	P240	VCC*	-
GND	P1	P1	P1	P2	GND*	P1	GND*	-
I/O, PGCK1 †, GCK1 †† (A16)	P2	P2	P2	P4	C3	P2	B1	170
I/O (A17)	P3	P3	P3	P5	C4	P3	C2	173
I/O	P4	P4	P4	P6	B3	P4	D2	176
I/O	P5	P5	P5	P7	C5	P5	D3	179
I/O, TDI	P6	P6	P6	P8	A2	P6	E4	182
I/O, TCK	P7	P7	P7	P9	B4	P7	C1	185
I/O	-	P8	P8	P10	C6	P8	D1	194
I/O	-	P9	P9	P11	A3	P9	E3	197
I/O	-	-	-	P12	B5	P10	E2	200
I/O	-	-	-	P13	B6	P11	E1	203
I/O	-	-	-	-	D5	P12	F3	206
I/O	-	-	-	-	D6	P13	F2	209
GND	P8	P10	P10	P14	GND*	P14	GND*	-
I/O	P9	P11	P11	P15	A4	P15	G3	212
I/O	P10	P12	P12	P16	A5	P16	G2	215
I/O, TMS	P11	P13	P13	P17	B7	P17	G1	218
I/O	P12	P14	P14	P18	A6	P18	H3	221
VCC	-	-	-	-	VCC*	P19	VCC*	-
I/O	-	-	-	-	D7	P20	H2	224
I/O	-	-	-	-	D8	P21	H1	227
I/O	-	-	-	-	-	-	J4	230
I/O	-	-	-	-	-	-	J3	233
I/O	-	-	P15	P19	C8	P23	J2	236
I/O	-	-	P16	P20	A7	P24	J1	239
I/O	P13	P15	P17	P21	B8	P25	K2	242
I/O	P14	P16	P18	P22	A8	P26	K3	245
I/O	P15	P17	P19	P23	B9	P27	K1	248
I/O	P16	P18	P20	P24	C9	P28	L1	251
GND	P17	P19	P21	P25	GND*	P29	GND*	-
VCC	P18	P20	P22	P26	VCC*	P30	VCC*	-
I/O	P19	P21	P23	P27	C10	P31	L2	254
I/O	P20	P22	P24	P28	B10	P32	L3	257
I/O	P21	P23	P25	P29	A9	P33	L4	260
I/O	P22	P24	P26	P30	A10	P34	M1	263
I/O	-	-	P27	P31	A11	P35	M2	266
I/O	-	-	P28	P32	C11	P36	M3	269
I/O	-	-	-	-	-	-	M4	272
I/O	-	-	-	-	D11	P38	N1	278
I/O	-	-	-	-	D12	P39	N2	281
VCC	-	-	-	-	VCC*	P40	VCC*	-
I/O	P23	P25	P29	P33	B11	P41	P1	284

XC4020E/XL Pad Name	HT 144††	PQ 160††	HT 176††	HQ208† PQ208††	PG 223†	HQ240† PQ240††	BG 256††	Bndry Scan
I/O	P24	P26	P30	P34	A12	P42	P2	287
I/O	P25	P27	P31	P35	B12	P43	R1	290
I/O	P26	P28	P32	P36	A13	P44	P3	293
GND	P27	P29	P33	P37	GND*	P45	GND*	-
I/O	-	-	-	-	D13	P46	T1	296
I/O	-	-	-	-	D14	P47	R3	299
I/O	-	-	-	P38	B13	P48	T2	302
I/O	-	-	-	P39	A14	P49	U1	305
I/O	-	P30	P34	P40	A15	P50	T3	308
I/O	-	P31	P35	P41	C13	P51	U2	311
I/O	P28	P32	P36	P42	B14	P52	V1	320
I/O	P29	P33	P37	P43	A16	P53	T4	323
I/O	P30	P34	P38	P44	B15	P54	U3	326
I/O	P31	P35	P39	P45	C14	P55	V2	329
I/O	P32	P36	P40	P46	A17	P56	W1	332
I/O, SGCK2 †, GCK2 ††	P33	P37	P41	P47	B16	P57	V3	335
O (M1)	P34	P38	P42	P48	C15	P58	W2	338
GND	P35	P39	P43	P49	GND*	P59	GND*	-
I (M0)	P36	P40	P44	P50	A18	P60	Y1	341
VCC	P37	P41	P45	P55	VCC*	P61	VCC*	-
I (M2)	P38	P42	P46	P56	C16	P62	W3	342
I/O, PGCK2 †, GCK3 ††	P39	P43	P47	P57	B17	P63	Y2	343
I/O (HDC)	P40	P44	P48	P58	E16	P64	W4	346
I/O	P41	P45	P49	P59	C17	P65	V4	349
I/O	P42	P46	P50	P60	D17	P66	U5	352
I/O	P43	P47	P51	P61	B18	P67	Y3	355
I/O (LDC)	P44	P48	P52	P62	E17	P68	Y4	358
I/O	-	P49	P53	P63	F16	P69	V5	367
I/O	-	P50	P54	P64	C18	P70	W5	370
I/O	-	-	-	P65	D18	P71	Y5	373
I/O	-	-	-	P66	F17	P72	V6	376
I/O	-	-	-	-	E15	P73	W6	379
I/O	-	-	-	-	F15	P74	Y6	382
GND	P45	P51	P55	P67	GND*	P75	GND*	-
I/O	P46	P52	P56	P68	E18	P76	W7	385
I/O	P47	P53	P57	P69	F18	P77	Y7	388
I/O	P48	P54	P58	P70	G17	P78	V8	391
I/O	P49	P55	P59	P71	G18	P79	W8	394
VCC	-	-	-	-	VCC*	P80	VCC*	-
I/O	-	-	P60	P72	H16	P81	Y8	397
I/O	-	-	P61	P73	H17	P82	U9	400
I/O	-	-	-	-	-	-	V9	403
I/O	-	-	-	-	-	-	W9	406
I/O	-	-	-	-	G15	P84	Y9	409
I/O	-	-	-	-	H15	P85	W10	412
I/O	P50	P56	P62	P74	H18	P86	V10	415
I/O	P51	P57	P63	P75	J18	P87	Y10	418
I/O	P52	P58	P64	P76	J17	P88	Y11	421
I/O (INIT)	P53	P59	P65	P77	J16	P89	W11	424
VCC	P54	P60	P66	P78	VCC*	P90	VCC*	-
GND	P55	P61	P67	P79	GND*	P91	GND*	-
I/O	P56	P62	P68	P80	K16	P92	V11	427
I/O	P57	P63	P69	P81	K17	P93	U11	430
I/O	P58	P64	P70	P82	K18	P94	Y12	433
I/O	P59	P65	P71	P83	L18	P95	W12	436
I/O	-	-	P72	P84	L17	P96	V12	439
I/O	-	-	P73	P85	L16	P97	U12	442
I/O	-	-	-	-	-	-	Y13	445
I/O	-	-	-	-	-	-	W13	448
I/O	-	-	-	-	L15	P99	V13	451
I/O	-	-	-	-	M15	P100	Y14	454
VCC	-	-	-	-	VCC*	P101	VCC*	-
I/O	P60	P66	P74	P86	M18	P102	Y15	457
I/O	P61	P67	P75	P87	M17	P103	V14	460
I/O	P62	P68	P76	P88	N18	P104	W15	463
I/O	P63	P69	P77	P89	P18	P105	Y16	466
GND	P64	P70	P78	P90	GND*	P106	GND*	-
I/O	-	-	-	-	N15	P107	V15	469
I/O	-	-	-	-	P15	P108	W16	472
I/O	-	-	-	P91	N17	P109	Y17	475
I/O	-	-	-	P92	R18	P110	V16	478
I/O	-	-	P79	P93	T18	P111	W17	481
I/O	-	-	P72	P80	P94	P112	Y18	484

XC4020E/XL Pad Name	HT 144††	PQ 160††	HT 176††	HQ208† PQ208††	PG 223†	HQ240† PQ240††	BG 256††	Bndry Scan
I/O	P65	P73	P81	P95	N16	P113	U16	493
I/O	P66	P74	P82	P96	T17	P114	V17	496
I/O	P67	P75	P83	P97	R17	P115	W18	499
I/O	P68	P76	P84	P98	P16	P116	Y19	502
I/O	P69	P77	P85	P99	U18	P117	V18	505
I/O, SGCK3 †, GCK4 ††	P70	P78	P86	P100	T16	P118	W19	508
GND	P71	P79	P87	P101	GND*	P119	GND*	-
DONE	P72	P80	P88	P103	U17	P120	Y20	-
VCC	P73	P81	P89	P106	VCC*	P121	VCC*	-
PROGRAM	P74	P82	P90	P108	V18	P122	V19	-
I/O (D7)	P75	P83	P91	P109	T15	P123	U19	511
I/O, PGCK3 †, GCK5 ††	P76	P84	P92	P110	U16	P124	U18	514
I/O	P77	P85	P93	P111	T14	P125	T17	517
I/O	P78	P86	P94	P112	U15	P126	V20	520
I/O	-	-	-	-	R14	P127	U20	523
I/O	-	-	-	-	R13	P128	T18	526
I/O (D6)	P79	P87	P95	P113	V17	P129	T19	535
I/O	P80	P88	P96	P114	V16	P130	T20	538
I/O	-	P89	P97	P115	T13	P131	R18	541
I/O	-	P90	P98	P116	U14	P132	R19	544
I/O	-	-	-	P117	V15	P133	R20	547
I/O	-	-	-	P118	V14	P134	P18	550
GND	P81	P91	P99	P119	GND*	P135	GND*	-
I/O	-	-	-	-	R12	P136	P20	553
I/O	-	-	-	-	R11	P137	N18	556
I/O	P82	P92	P100	P120	U13	P138	N19	559
I/O	P83	P93	P101	P121	V13	P139	N20	562
VCC	-	-	-	-	VCC*	P140	VCC*	-
I/O (D5)	P84	P94	P102	P122	U12	P141	M17	565
I/O (CS0)	P85	P95	P103	P123	V12	P142	M18	568
I/O	-	-	-	-	-	-	M19	574
I/O	-	-	P104	P124	T11	P144	M20	577
I/O	-	-	P105	P125	U11	P145	L19	580
I/O	P86	P96	P106	P126	V11	P146	L18	583
I/O	P87	P97	P107	P127	V10	P147	L20	586
I/O (D4)	P88	P98	P108	P128	U10	P148	K20	589
I/O	P89	P99	P109	P129	T10	P149	K19	592
VCC	P90	P100	P110	P130	VCC*	P150	VCC*	-
GND	P91	P101	P111	P131	GND*	P151	GND*	-
I/O (D3)	P92	P102	P112	P132	T9	P152	K18	595
I/O (RS)	P93	P103	P113	P133	U9	P153	K17	598
I/O	P94	P104	P114	P134	V9	P154	J20	601
I/O	P95	P105	P115	P135	V8	P155	J19	604
I/O	-	-	P116	P136	U8	P156	J18	607
I/O	-	-	P117	P137	T8	P157	J17	610
I/O	-	-	-	-	-	-	H20	613
I/O (D2)	P96	P106	P118	P138	V7	P159	H19	619
I/O	P97	P107	P119	P139	U7	P160	H18	622
VCC	-	-	-	-	VCC*	P161	VCC*	-
I/O	P98	P108	P120	P140	V6	P162	G19	625
I/O	P99	P109	P121	P141	U6	P163	F20	628
I/O	-	-	-	-	R8	P164	G18	631
I/O	-	-	-	-	R7	P165	F19	634
GND	P100	P110	P122	P142	GND*	P166	GND*	-
I/O	-	-	-	-	R6	P167	F18	637
I/O	-	-	-	-	R5	P168	E19	640
I/O	-	-	-	P143	V5	P169	D20	643
I/O	-	-	-	P144	V4	P170	E18	646
I/O	-	P111	P123	P145	U5	P171	D19	649
I/O	-	P112	P124	P146	T6	P172	C20	652
I/O (D1)	P101	P113	P125	P147	V3	P173	E17	655
I/O (RCLK, RDY/BUSY)	P102	P114	P126	P148	V2	P174	D18	658
I/O	P103	P115	P127	P149	U4	P175	C19	667
I/O	P104	P116	P128	P150	T5	P176	B20	670
I/O (D0, DIN)	P105	P117	P129	P151	U3	P177	C18	673
I/O, SGCK4 †, GCK6 †† (DOUT)	P106	P118	P130	P152	T4	P178	B19	676
CCLK	P107	P119	P131	P153	V1	P179	A20	-
VCC	P108	P120	P132	P154	VCC*	P180	VCC*	-
O, TDO	P109	P121	P133	P159	U2	P181	A19	0
GND	P110	P122	P134	P160	GND*	P182	GND*	-
I/O (A0, WS)	P111	P123	P135	P161	T3	P183	B18	2
I/O, PGCK4 †, GCK7 †† (A1)	P112	P124	P136	P162	U1	P184	B17	5
I/O	P113	P125	P137	P163	P3	P185	C17	8
I/O	P114	P126	P138	P164	R2	P186	D16	11
I/O (CS1, A2)	P115	P127	P139	P165	T2	P187	A18	14
I/O (A3)	P116	P128	P140	P166	N3	P188	A17	17

XC4020E/XL Pad Name	HT 144††	PQ 160††	HT 176††	HQ208† PQ208††	PG 223†	HQ240† PQ240††	BG 256††	Bndry Scan
I/O	-	-	-	-	P4	P189	C16	26
I/O	-	-	-	-	N4	P190	B16	29
I/O	P117	P129	P141	P167	P2	P191	A16	32
I/O	-	P130	P142	P168	T1	P192	C15	35
I/O	-	-	-	P169	R1	P193	B15	38
I/O	-	-	-	P170	N2	P194	A15	41
GND	P118	P131	P143	P171	GND*	P196	GND*	-
I/O	P119	P132	P144	P172	P1	P197	B14	44
I/O	P120	P133	P145	P173	N1	P198	A14	47
I/O	-	-	-	-	M4	P199	C13	50
I/O	-	-	-	-	L4	P200	B13	53
VCC	-	-	-	-	VCC*	P201	VCC*	-
I/O	-	-	-	-	-	-	A13	56
I/O	-	-	-	-	-	-	D12	59
I/O (A4)	P121	P134	P146	P174	M2	P202	C12	62
I/O (A5)	P122	P135	P147	P175	M1	P203	B12	65
I/O	-	-	P148	P176	L3	P205	A12	68
I/O	-	P136	P149	P177	L2	P206	B11	71
I/O (A21) ††	P123	P137	P150	P178	L1	P207	C11	74
I/O (A20) ††	P124	P138	P151	P179	K1	P208	A11	77
I/O (A6)	P125	P139	P152	P180	K2	P209	A10	80
I/O (A7)	P126	P140	P153	P181	K3	P210	B10	83
GND	P127	P141	P154	P182	GND*	P211	GND*	-

6/24/97

† = E only

†† = XL only

Additional XC4020E/XL Package Pins

PQ/HQ208

N.C. Pins					
P1	P3	P51	P52	P53	P54
P102	P104	P105	P107	P155	P156
P157	P158	P206	P207	P208	-

5/5/97

PG223

VCC Pins					
D3	D10	D16	J4	J15	R4
R10	R15	-	-	-	-
GND Pins					
C7	C12	D4	D9	D15	G3
G16	K4	K15	M3	M16	R3
R9	R16	T7	T12	-	-

5/5/97

PQ/HQ240

GND Pins					
P22‡	P37‡	P83‡	P98‡	P143‡	P158‡
P204‡	P219‡	-	-	-	-
N.C. Pins					
P195	-	-	-	-	-

6/9/97

‡ Pins marked with this symbol are used for Ground connections on some revisions of the device. These pins may not physically connect to anything on the current device revision. However, they should be externally connected to Ground, if possible.

BG256

VCC Pins					
C14	D6	D7	D11	D14	D15
E20	F1	F4	F17	G4	G17
K4	L17	P4	P17	P19	R2
R4	R17	U6	U7	U10	U14
U15	V7	W20	-	-	-
GND Pins					
A1	B7	D4	D8	D13	D17
G20	H4	H17	N3	N4	N17
U4	U8	U13	U17	W14	-

6/17/97

Pin Locations for XC4025E, XC4028EX/XL Devices

The following table may contain pinout information for unsupported device/package combinations. Please see the availability charts elsewhere in the XC4000 Series data sheet for availability information.

XC4025E, XC4028 EX/XL Pad Name	HQ 160††	HQ 208‡	PG 223‡	HQ 240	BG 256††	PG 299	HQ 304	BG 352‡	Bndry Scan
VCC	P142	P183	VCC*	P212	VCC*	VCC*	P38	VCC*	-
I/O (A8)	P143	P184	J3	P213	C10	K2	P37	D14	98
I/O (A9)	P144	P185	J2	P214	D10	K3	P36	C14	101
I/O (A19) ‡	P145	P186	J1	P215	A9	K5	P35	A15	104
I/O (A18) ‡	P146	P187	H1	P216	B9	K4	P34	B15	107
I/O	-	P188	H2	P217	C9	J1	P33	C15	110
I/O	-	P189	H3	P218	D9	J2	P32	D15	113
I/O (A10)	P147	P190	G1	P220	A8	H1	P31	A16	116
I/O (A11)	P148	P191	G2	P221	B8	J3	P30	B16	119
GND	-	-	-	-	GND*	GND*	-	GND*	-
I/O	-	-	-	-	-	J4	P29	C16	122
I/O	-	-	-	-	-	J5	P28	B17	125
I/O	-	-	-	-	C8	H2	P27	C17	128
I/O	-	-	-	-	A7	G1	P26	B18	131
VCC	-	-	VCC*	P222	VCC*	VCC*	P25	VCC*	-
I/O	-	-	H4	P223	A6	H3	P23	C18	134
I/O	-	-	G4	P224	C7	G2	P22	D17	137
I/O	P149	P192	F1	P225	B6	H4	P21	A20	140
I/O	P150	P193	E1	P226	A5	F2	P20	B19	143
GND	P151	P194	GND*	P227	GND*	GND*	P19	GND*	-
I/O	-	-	-	-	-	H5	P18	C19	146
I/O	-	-	-	-	-	G3	P17	D18	149
I/O	-	P195	F2	P228	C6	D1	P16	A21	152
I/O	-	P196	D1	P229	B5	G4	P15	B20	155
I/O	P152	P197	C1	P230	A4	E2	P14	C20	158
I/O	P153	P198	E2	P231	C5	F3	P13	B21	161
I/O (A12)	P154	P199	F3	P232	B4	G5	P12	B22	164
I/O (A13)	P155	P200	D2	P233	A3	C1	P10	C21	167
GND	-	-	-	-	GND*	GND*	-	GND*	-
VCC	-	-	-	-	VCC*	VCC*	-	VCC*	-
I/O	-	-	-	-	-	F4	P9	D20	170
I/O	-	-	-	-	-	E3	P8	A23	173
I/O	-	-	F4	P234	D5	D2	P7	D21	176
I/O	-	-	E4	P235	C4	C2	P6	C22	179
I/O	P156	P201	B1	P236	B3	F5	P5	B24	182
I/O	P157	P202	E3	P237	B2	E4	P4	C23	185
I/O (A14)	P158	P203	C2	P238	A2	D3	P3	D22	188
I/O, SGCK1 †, GCK8 ‡ (A15)	P159	P204	B2	P239	C3	C3	P2	C24	191
VCC	P160	P205	VCC*	P240	VCC*	VCC*	P1	VCC*	-
GND	P1	P2	GND*	P1	GND*	GND*	P304	GND*	-
I/O, PGCK1 †, GCK1 ‡ (A16)	P2	P4	C3	P2	B1	D4	P303	D23	194
I/O (A17)	P3	P5	C4	P3	C2	B2	P302	C25	197
I/O	P4	P6	B3	P4	D2	B3	P301	D24	200
I/O	P5	P7	C5	P5	D3	E6	P300	E23	203
I/O, TDI	P6	P8	A2	P6	E4	D5	P299	C26	206
I/O, TCK	P7	P9	B4	P7	C1	C4	P298	E24	209
I/O	-	-	-	-	-	A3	P297	F24	212
I/O	-	-	-	-	-	D6	P296	E25	215
VCC	-	-	-	-	VCC*	VCC*	-	VCC*	-
GND	-	-	-	-	GND*	GND*	-	GND*	-
I/O	P8	P10	C6	P8	D1	E7	P295	D26	218
I/O	P9	P11	A3	P9	E3	B4	P294	G24	221
I/O	-	P12	B5	P10	E2	C5	P293	F25	224
I/O	-	P13	B6	P11	E1	A4	P292	F26	227
I/O	-	-	D5	P12	F3	D7	P291	H23	230
I/O	-	-	D6	P13	F2	C6	P290	H24	233
I/O	-	-	-	-	-	E8	P289	G25	236

XC4025E, XC4028 EX/XL Pad Name	HQ 160††	HQ 208‡	PG 223‡	HQ 240	BG 256††	PG 299	HQ 304	BG 352‡	Bndry Scan
I/O	-	-	-	-	-	B5	P288	G26	239
GND	P10	P14	GND*	P14	GND*	GND*	P287	GND*	-
I/O	P11	P15	A4	P15	G3	B6	P286	J23	242
I/O	P12	P16	A5	P16	G2	D8	P285	J24	245
I/O, TMS	P13	P17	B7	P17	G1	C7	P284	H25	248
I/O	P14	P18	A6	P18	H3	B7	P283	K23	251
VCC	-	-	VCC*	P19	VCC*	VCC*	P282	VCC*	-
I/O	-	-	D7	P20	H2	C8	P280	K24	254
I/O	-	-	D8	P21	H1	E9	P279	J25	257
I/O	-	-	-	-	-	A7	P278	L24	260
I/O	-	-	-	-	-	D9	P277	K25	263
GND	-	-	-	P22	GND*	GND*	-	GND*	-
I/O	-	-	-	-	J4	B8	P276	L25	266
I/O	-	-	-	-	J3	A8	P275	L26	269
I/O	-	P19	C8	P23	J2	C9	P274	M23	272
I/O	-	P20	A7	P24	J1	B9	P273	M24	275
I/O	P15	P21	B8	P25	K2	E10	P272	M25	278
I/O	P16	P22	A8	P26	K3	A9	P271	M26	281
I/O	P17	P23	B9	P27	K1	D10	P270	N24	284
I/O	P18	P24	C9	P28	L1	C10	P269	N25	287
GND	P19	P25	GND*	P29	GND*	GND*	P268	GND*	-
VCC	P20	P26	VCC*	P30	VCC*	VCC*	P267	VCC*	-
I/O	P21	P27	C10	P31	L2	B10	P266	N26	290
I/O	P22	P28	B10	P32	L3	B11	P265	P25	293
I/O	P23	P29	A9	P33	L4	C11	P264	P23	296
I/O	P24	P30	A10	P34	M1	E11	P263	P24	299
I/O	-	P31	A11	P35	M2	D11	P262	R26	302
I/O	-	P32	C11	P36	M3	A12	P261	R25	305
I/O	-	-	-	-	M4	B12	P260	R24	308
I/O	-	-	-	-	-	A13	P259	R23	311
GND	-	-	-	P37	GND*	GND*	-	GND*	-
I/O	-	-	-	-	-	C12	P258	T26	314
I/O	-	-	-	-	-	D12	P257	T25	317
I/O	-	-	D11	P38	N1	E12	P256	T23	320
I/O	-	-	D12	P39	N2	B13	P255	V26	323
VCC	-	-	VCC*	P40	VCC*	VCC*	P253	VCC*	-
I/O	P25	P33	B11	P41	P1	A14	P252	U24	326
I/O	P26	P34	A12	P42	P2	C13	P251	V25	329
I/O	P27	P35	B12	P43	R1	B14	P250	V24	332
I/O	P28	P36	A13	P44	P3	D13	P249	U23	335
GND	P29	P37	GND*	P45	GND*	GND*	P248	GND*	-
I/O	-	-	-	-	-	B15	P247	Y26	338
I/O	-	-	-	-	-	E13	P246	W25	341
I/O	-	-	D13	P46	T1	C14	P245	W24	344
I/O	-	-	D14	P47	R3	A17	P244	V23	347
I/O	-	P38	B13	P48	T2	D14	P243	AA26	350
I/O	-	P39	A14	P49	U1	B16	P242	Y25	353
I/O	P30	P40	A15	P50	T3	C15	P241	Y24	356
I/O	P31	P41	C13	P51	U2	E14	P240	AA25	359
GND	-	-	-	-	GND*	GND*	-	GND*	-
VCC	-	-	-	-	VCC*	VCC*	-	VCC*	-
I/O	-	-	-	-	-	A18	P239	AB25	362
I/O	-	-	-	-	-	D15	P238	AA24	365
I/O	P32	P42	B14	P52	V1	C16	P237	Y23	368
I/O	P33	P43	A16	P53	T4	B17	P236	AC26	371
I/O	P34	P44	B15	P54	U3	B18	P235	AA23	374
I/O	P35	P45	C14	P55	V2	E15	P234	AB24	377
I/O	P36	P46	A17	P56	W1	D16	P233	AD25	380
I/O, SGCK2 †, GCK2 ‡	P37	P47	B16	P57	V3	C17	P232	AC24	383
O (M1)	P38	P48	C15	P58	W2	A20	P231	AB23	386
GND	P39	P49	GND*	P59	GND*	GND*	P230	GND*	-

XC4000E and XC4000X Series Field Programmable Gate Arrays

XC4025E, XC4028 EX/XL Pad Name	HQ 160††	HQ 208‡	PG 223†	HQ 240	BG 256††	PG 299	HQ 304	BG 352‡	Bndry Scan
I (M0)	P40	P50	A18	P60	Y1	C18	P229	AD24	389
VCC	P41	P55	VCC*	P61	VCC*	VCC*	P228	VCC*	-
I (M2)	P42	P56	C16	P62	W3	D17	P227	AC23	390
I/O, PGCK2 †, GCK3 ‡	P43	P57	B17	P63	Y2	B19	P226	AE24	391
I/O (HDC)	P44	P58	E16	P64	W4	C19	P225	AD23	394
I/O	P45	P59	C17	P65	V4	F16	P224	AC22	397
I/O	P46	P60	D17	P66	U5	E17	P223	AF24	400
I/O	P47	P61	B18	P67	Y3	D18	P222	AD22	403
I/O (LDC)	P48	P62	E17	P68	Y4	C20	P221	AE23	406
I/O	-	-	-	-	-	F17	P220	AE22	409
I/O	-	-	-	-	-	G16	P219	AF23	412
VCC	-	-	-	-	VCC*	VCC*	-	VCC*	-
GND	-	-	-	-	GND*	GND*	-	GND*	-
I/O	P49	P63	F16	P69	V5	D19	P218	AD20	415
I/O	P50	P64	C18	P70	W5	E18	P217	AE21	418
I/O	-	P65	D18	P71	Y5	D20	P216	AF21	421
I/O	-	P66	F17	P72	V6	G17	P215	AC19	424
I/O	-	E15	P73	W6	F18	P214	AD19	427	
I/O	-	F15	P74	Y6	H16	P213	AE20	430	
I/O	-	-	-	-	-	E19	P212	AF20	433
I/O	-	-	-	-	-	F19	P211	AC18	436
GND	P51	P67	GND*	P75	GND*	GND*	P210	GND*	-
I/O	P52	P68	E18	P76	W7	H17	P209	AD18	439
I/O	P53	P69	F18	P77	Y7	G18	P208	AE19	442
I/O	P54	P70	G17	P78	V8	G19	P207	AC17	445
I/O	P55	P71	G18	P79	W8	H18	P206	AD17	448
VCC	-	-	VCC*	P80	VCC*	VCC*	P204	VCC*	-
I/O	-	P72	H16	P81	Y8	J16	P203	AE18	451
I/O	-	P73	H17	P82	U9	G20	P202	AF18	454
I/O	-	-	-	-	-	J17	P201	AE17	457
I/O	-	-	-	-	-	H19	P200	AE16	460
GND	-	-	-	P83	GND*	GND*	-	GND*	-
I/O	-	-	-	-	V9	H20	P199	AF16	463
I/O	-	-	-	-	W9	J18	P198	AC15	466
I/O	-	-	G15	P84	Y9	J19	P197	AD15	469
I/O	-	-	H15	P85	W10	K16	P196	AE15	472
I/O	P56	P74	H18	P86	V10	J20	P195	AF15	475
I/O	P57	P75	J18	P87	Y10	K17	P194	AD14	478
I/O	P58	P76	J17	P88	Y11	K18	P193	AE14	481
I/O (INIT)	P59	P77	J16	P89	W11	K19	P192	AF14	484
VCC	P60	P78	VCC*	P90	VCC*	VCC*	P191	VCC*	-
GND	P61	P79	GND*	P91	GND*	GND*	P190	GND*	-
I/O	P62	P80	K16	P92	V11	L19	P189	AE13	487
I/O	P63	P81	K17	P93	U11	L18	P188	AC13	490
I/O	P64	P82	K18	P94	Y12	L16	P187	AD13	493
I/O	P65	P83	L18	P95	W12	L17	P186	AF12	496
I/O	-	P84	L17	P96	V12	M20	P185	AE12	499
I/O	-	P85	L16	P97	U12	M19	P184	AD12	502
I/O	-	-	-	-	Y13	N20	P183	AC12	505
I/O	-	-	-	-	W13	M18	P182	AF11	508
GND	-	-	-	P98	GND*	GND*	-	GND*	-
I/O	-	-	-	-	-	M17	P181	AE11	511
I/O	-	-	-	-	-	M16	P180	AD11	514
I/O	-	-	L15	P99	V13	N19	P179	AF9	517
I/O	-	-	M15	P100	Y14	P20	P178	AD10	520
VCC	-	-	VCC*	P101	VCC*	VCC*	P177	VCC*	-
I/O	P66	P86	M18	P102	Y15	N18	P175	AE9	523
I/O	P67	P87	M17	P103	V14	P19	P174	AD9	526
I/O	P68	P88	N18	P104	W15	N17	P173	AC10	529
I/O	P69	P89	P18	P105	Y16	R19	P172	AF7	532
GND	P70	P90	GND*	P106	GND*	GND*	P171	GND*	-
I/O	-	-	-	-	-	N16	P170	AE8	535
I/O	-	-	-	-	-	P18	P169	AD8	538
I/O	-	-	N15	P107	V15	U20	P168	AC9	541
I/O	-	-	P15	P108	W16	P17	P167	AF6	544
I/O	-	P91	N17	P109	Y17	T19	P166	AE7	547

XC4025E, XC4028 EX/XL Pad Name	HQ 160††	HQ 208‡	PG 223†	HQ 240	BG 256††	PG 299	HQ 304	BG 352‡	Bndry Scan
I/O	-	P92	R18	P110	V16	R18	P165	AD7	550
I/O	P71	P93	T18	P111	W17	P16	P164	AE6	553
I/O	P72	P94	P17	P112	Y18	V20	P163	AE5	556
GND	-	-	-	-	GND*	GND*	-	GND*	-
VCC	-	-	-	-	VCC*	VCC*	-	VCC*	-
I/O	-	-	-	-	-	R17	P162	AD6	559
I/O	-	-	-	-	-	T18	P161	AC7	562
I/O	P73	P95	N16	P113	U16	U19	P160	AF4	565
I/O	P74	P96	T17	P114	V17	V19	P159	AF3	568
I/O	P75	P97	R17	P115	W18	R16	P158	AD5	571
I/O	P76	P98	P16	P116	Y19	T17	P157	AE3	574
I/O	P77	P99	U18	P117	V18	U18	P156	AD4	577
I/O, SGCK3 †, GCK4 ‡	P78	P100	T16	P118	W19	X20	P155	AC5	580
GND	P79	P101	GND*	P119	GND*	GND*	P154	GND*	-
DONE	P80	P103	U17	P120	Y20	V18	P153	AD3	-
VCC	P81	P106	VCC*	P121	VCC*	VCC*	P152	VCC*	-
PRO- GRAM	P82	P108	V18	P122	V19	U17	P151	AC4	-
I/O (D7)	P83	P109	T15	P123	U19	W19	P150	AD2	583
I/O, PGCK3 †, GCK5 ‡	P84	P110	U16	P124	U18	W18	P149	AC3	586
I/O	P85	P111	T14	P125	T17	T15	P148	AB4	589
I/O	P86	P112	U15	P126	V20	U16	P147	AD1	592
I/O	-	-	R14	P127	U20	V17	P146	AA4	595
I/O	-	-	R13	P128	T18	X18	P145	AA3	598
I/O	-	-	-	-	-	U15	P144	AB2	601
I/O	-	-	-	-	-	T14	P143	AC1	604
VCC	-	-	-	-	VCC*	VCC*	-	VCC*	-
GND	-	-	-	-	GND*	GND*	-	GND*	-
I/O (D6)	P87	P113	V17	P129	T19	W17	P142	Y3	607
I/O	P88	P114	V16	P130	T20	V16	P141	AA2	610
I/O	P89	P115	T13	P131	R18	X17	P140	AA1	613
I/O	P90	P116	U14	P132	R19	U14	P139	W4	616
I/O	-	P117	V15	P133	R20	V15	P138	W3	619
I/O	-	P118	V14	P134	P18	T13	P137	Y2	622
I/O	-	-	-	-	-	W16	P136	Y1	625
I/O	-	-	-	-	-	W15	P135	V4	628
GND	P91	P119	GND*	P135	GND*	GND*	P134	GND*	-
I/O	-	-	R12	P136	P20	U13	P133	V3	631
I/O	-	-	R11	P137	N18	V14	P132	W2	634
I/O	P92	P120	U13	P138	N19	W14	P131	U4	637
I/O	P93	P121	V13	P139	N20	V13	P130	U3	640
VCC	-	-	VCC*	P140	VCC*	VCC*	P129	VCC*	-
I/O (D5)	P94	P122	U12	P141	M17	T12	P127	V2	643
I/O (CS0)	P95	P123	V12	P142	M18	X14	P126	V1	646
I/O	-	-	-	-	-	U12	P125	U2	649
I/O	-	-	-	-	-	W13	P124	T2	652
GND	-	-	-	P143	GND*	GND*	-	GND*	-
I/O	-	-	-	-	-	X13	P123	T1	655
I/O	-	-	-	-	M19	V12	P122	R4	658
I/O	-	P124	T11	P144	M20	W12	P121	R3	661
I/O	-	P125	U11	P145	L19	T11	P120	R2	664
I/O	P96	P126	V11	P146	L18	X12	P119	R1	667
I/O	P97	P127	V10	P147	L20	U11	P118	P3	670
I/O (D4)	P98	P128	U10	P148	K20	V11	P117	P2	673
I/O	P99	P129	T10	P149	K19	W11	P116	P1	676
VCC	P100	P130	VCC*	P150	VCC*	VCC*	P115	VCC*	-
GND	P101	P131	GND*	P151	GND*	GND*	P114	GND*	-
I/O (D3)	P102	P132	T9	P152	K18	W10	P113	N2	679
I/O (RS)	P103	P133	U9	P153	K17	V10	P112	N4	682
I/O	P104	P134	V9	P154	J20	T10	P111	N3	685
I/O	P105	P135	V8	P155	J19	U10	P110	M1	688
I/O	-	P136	U8	P156	J18	X9	P109	M2	691
I/O	-	P137	T8	P157	J17	W9	P108	M3	694
I/O	-	-	-	-	H20	X8	P107	M4	697

XC4025E, XC4028 EX/XL Pad Name	HQ 160††	HQ 208‡	PG 223†	HQ 240	BG 256††	PG 299	HQ 304	BG 352‡	Bndry Scan
I/O	-	-	-	-	-	V9	P106	L1	700
GND	-	-	-	P158	GND*	-	-	GND*	-
I/O	-	-	-	-	-	U9	P105	L2	703
I/O	-	-	-	-	-	T9	P104	L3	706
I/O (D2)	P106	P138	V7	P159	H19	W8	P103	J1	709
I/O	P107	P139	U7	P160	H18	X7	P102	K3	712
VCC	-	-	VCC*	P161	VCC*	VCC*	P101	VCC*	-
I/O	P108	P140	V6	P162	G19	V8	P99	J2	715
I/O	P109	P141	U6	P163	F20	W7	P98	J3	718
I/O	-	-	R8	P164	G18	U8	P97	K4	721
I/O	-	-	R7	P165	F19	W6	P96	G1	724
GND	P110	P142	GND*	P166	GND*	GND*	P95	GND*	-
I/O	-	-	-	-	-	T8	P94	H2	727
I/O	-	-	-	-	-	V7	P93	H3	730
I/O	-	-	R6	P167	F18	X4	P92	J4	733
I/O	-	-	R5	P168	E19	U7	P91	F1	736
I/O	-	P143	V5	P169	D20	W5	P90	G2	739
I/O	-	P144	V4	P170	E18	V6	P89	G3	742
I/O	P111	P145	U5	P171	D19	T7	P88	F2	745
I/O	P112	P146	T6	P172	C20	X3	P87	E2	748
GND	-	-	-	-	GND*	GND*	-	GND*	-
VCC	-	-	-	-	VCC*	VCC*	-	VCC*	-
I/O (D1)	P113	P147	V3	P173	E17	U6	P86	F3	751
I/O (RCLK, RDY/ BUSY)	P114	P148	V2	P174	D18	V5	P85	G4	754
I/O	-	-	-	-	-	W4	P84	D2	757
I/O	-	-	-	-	-	W3	P83	F4	760
I/O	P115	P149	U4	P175	C19	T6	P82	E3	763
I/O	P116	P150	T5	P176	B20	U5	P81	C2	766
I/O (D0, DIN)	P117	P151	U3	P177	C18	V4	P80	D3	769
I/O, SGCK4 †, GCK6 ‡ (DOU)	P118	P152	T4	P178	B19	X1	P79	E4	772
CCLK	P119	P153	V1	P179	A20	V3	P78	C3	-
VCC	P120	P154	VCC*	P180	VCC*	VCC*	P77	VCC*	-
O, TDO	P121	P159	U2	P181	A19	U4	P76	D4	0
GND	P122	P160	GND*	P182	GND*	GND*	P75	GND*	-
I/O (A0, WS)	P123	P161	T3	P183	B18	W2	P74	B3	2
I/O, PGCK4 †, GCK7 ‡ (A1)	P124	P162	U1	P184	B17	V2	P73	C4	5
I/O	P125	P163	P3	P185	C17	R5	P72	D5	8
I/O	P126	P164	R2	P186	D16	T4	P71	A3	11
I/O (CS1, A2)	P127	P165	T2	P187	A18	U3	P70	D6	14
I/O (A3)	P128	P166	N3	P188	A17	V1	P69	C6	17
I/O	-	-	-	-	-	R4	P68	B5	20
I/O	-	-	-	-	-	P5	P67	A4	23
VCC	-	-	-	-	VCC*	VCC*	-	VCC*	-
GND	-	-	-	-	GND*	GND*	-	GND*	-
I/O	-	-	P4	P189	C16	U2	P66	C7	26
I/O	-	-	N4	P190	B16	T3	P65	B6	29
I/O	P129	P167	P2	P191	A16	U1	P64	A6	32
I/O	P130	P168	T1	P192	C15	P4	P63	D8	35
I/O	-	P169	R1	P193	B15	R3	P62	B7	38
I/O	-	P170	N2	P194	A15	N5	P61	A7	41
I/O	-	-	-	P195	-	T2	P60	D9	44
I/O	-	-	-	-	-	R2	P59	C9	47
GND	P131	P171	GND*	P196	GND*	GND*	P58	GND*	-
I/O	P132	P172	P1	P197	B14	N4	P57	B8	50
I/O	P133	P173	N1	P198	A14	P3	P56	D10	53
I/O	-	-	M4	P199	C13	P2	P55	C10	56
I/O	-	-	L4	P200	B13	N3	P54	B9	59
VCC	-	-	VCC*	P201	VCC*	VCC*	P52	VCC*	-

XC4025E, XC4028 EX/XL Pad Name	HQ 160††	HQ 208‡	PG 223†	HQ 240	BG 256††	PG 299	HQ 304	BG 352‡	Bndry Scan
I/O	-	-	-	-	A13	M5	P51	A9	62
I/O	-	-	-	-	D12	P1	P50	D11	65
I/O	-	-	-	-	-	M4	P49	B11	68
I/O	-	-	-	-	-	N2	P48	A11	71
GND	-	-	-	-	GND*	GND*	-	GND*	-
I/O (A4)	P134	P174	M2	P202	C12	N1	P47	D12	74
I/O (A5)	P135	P175	M1	P203	B12	M3	P46	C12	77
I/O	-	P176	L3	P205	A12	M2	P45	B12	80
I/O	P136	P177	L2	P206	B11	L5	P44	A12	83
I/O (A21) ‡	P137	P178	L1	P207	C11	M1	P43	C13	86
I/O (A20) ‡	P138	P179	K1	P208	A11	L4	P42	B13	89
I/O (A6)	P139	P180	K2	P209	A10	L3	P41	A13	92
I/O (A7)	P140	P181	K3	P210	B10	L2	P40	B14	95
GND	P141	P182	GND*	P211	GND*	GND*	P39	GND*	-

6/19/97

* Pads labelled GND* or VCC* are internally bonded to Ground or VCC planes within the associated package. They have no direct connection to any specific package pin.

† = E only

†† = XL only

‡ = EX, XL only

Additional XC4025E, XC4028EX/XL Package Pins

HQ208

N.C. Pins					
P1	P52	P102	P107	P157	P207
P3	P53	P104	P155	P158	P208
P51	P54	P105	P156	P206	

5/9/97

PG223

VCC Pins			
D3	D10	D16	J4
J15	R4	R10	R15
GND Pins			
C7	C12	D4	D9
D15	G3	G16	K4
K15	M3	M16	R3
R9	R16	T7	T12

5/9/97

HQ240

GND Pins	
P204	P219

5/9/97

Note: These pins may be N.C. for this device revision, however for compatibility with other devices in this package, these pins should be tied to GND.

BG256

VCC Pins			
C14	D6	D7	D11
D14	D15	E20	F1
F4	F17	G4	G17
K4	L17	P4	P17
P19	R2	R4	R17
U6	U7	U10	U14
U15	V7	W20	-
GND Pins			
A1	B7	D4	D8
D13	D17	G20	H4
H17	N3	N4	N17
U4	U8	U13	U17
W14	-	-	-

5/9/97

PG299

VCC Pins			
A2	A6	A11	A16
B20	E1	E5	F20
K1	L20	R1	T16
T20	W1	X5	X10
X15	X19	-	-
GND Pins			
A5	A10	A15	A19
B1	E16	E20	F1
K20	L1	R20	T1
T5	W20	X2	X6
X11	X16	-	-

6/18/97

HQ304

N.C. Pins				
P11	P53	P128	P205	P281
P24	P100	P176	P254	-

5/15/97

Note: In XC4025 (no extension) devices in the HQ304 package, P101 is a No Connect (N.C.) pin. P101 is Vcc in XC4025E and XC4028EX/XL devices. Where necessary for compatibility, this pin can be left unconnected.

BG352

VCC Pins					
A10	A17	B2	B25	D7	D13
D19	G23	H4	K1	K26	N23
P4	U1	U26	W23	Y4	AC8
AC14	AC20	AE2	AE25	AF10	AF17
GND Pins					
A1	A2	A5	A8	A14	A19
A22	A25	A26	B1	B26	E1
E26	H1	H26	N1	P26	W1
W26	AB1	AB26	AE1	AE26	AF1
AF2	AF5	AF8	AF13	AF19	AF22
AF25	AF26	-	-	-	-
N.C. Pins					
A18	A24	B4	B10	B23	C1
C5	C8	C11	D1	D16	D25
F23	J26	K2	L4	L23	T3
T4	T24	U25	AB3	AC2	AC6
AC11	AC16	AC21	AC25	AD16	AD21
AD26	AE4	AE10	-	-	-

5/9/97

Pin Locations for XC4036EX/XL

The following table may contain pinout information for unsupported device/package combinations. Please see the availability charts elsewhere in the XC4000 Series data sheet for availability information.

XC4036EX/XL Pad Name	PQ 160††	HQ 208††	HQ 240	HQ 304	BG 352	PG 411	BG 432	Bndry Scan
VCC	P142	P183	P212	P38	VCC*	VCC*	VCC*	-
I/O (A8)	P143	P184	P213	P37	D14	W3	D17	110
I/O (A9)	P144	P185	P214	P36	C14	Y2	A17	113
I/O (A19)	P145	P186	P215	P35	A15	V4	C18	116
I/O (A18)	P146	P187	P216	P34	B15	T2	D18	119
I/O	-	P188	P217	P33	C15	U1	B18	122
I/O	-	P189	P218	P32	D15	V6	A19	125
I/O (A10)	P147	P190	P220	P31	A16	U3	B19	128
I/O (A11)	P148	P191	P221	P30	B16	R1	C19	131
VCC	-	-	-	-	VCC*	VCC*	VCC*	-
GND	-	-	-	-	GND*	GND*	GND*	-
I/O	-	-	-	P29	C16	U5	D19	134
I/O	-	-	-	P28	B17	T4	A20	137
I/O	-	-	-	-	D16	P2	B20	140
I/O	-	-	-	-	A18	N1	C20	143
I/O	-	-	-	P27	C17	R5	C21	146
I/O	-	-	-	P26	B18	M2	A22	149
VCC	-	-	P222	P25	VCC*	VCC*	VCC*	-
I/O	-	-	P223	P23	C18	L3	B22	152
I/O	-	-	P224	P22	D17	T6	C22	155
I/O	P149	P192	P225	P21	A20	N5	B23	158
I/O	P150	P193	P226	P20	B19	M4	A24	161
GND	P151	P194	P227	P19	GND*	GND*	GND*	-
I/O	-	-	-	P18	C19	K2	D22	164
I/O	-	-	-	P17	D18	K4	C23	167
I/O	-	P195	P228	P16	A21	P6	B24	170
I/O	-	P196	P229	P15	B20	M6	C24	173
I/O	P152	P197	P230	P14	C20	J3	A26	176
I/O	P153	P198	P231	P13	B21	H2	C25	179
I/O (A12)	P154	P199	P232	P12	B22	H4	D24	182

XC4036EX/XL Pad Name	PQ 160††	HQ 208††	HQ 240	HQ 304	BG 352	PG 411	BG 432	Bndry Scan
I/O (A13)	P155	P200	P233	P10	C21	G3	B26	185
GND	-	-	-	-	GND*	GND*	GND*	-
VCC	-	-	-	-	VCC*	VCC*	VCC*	-
I/O	-	-	-	P9	D20	K6	A27	188
I/O	-	-	-	P8	A23	G1	D25	191
I/O	-	-	-	-	A24	E1	C26	194
I/O	-	-	-	-	B23	E3	B27	197
I/O	-	-	P234	P7	D21	J7	C27	200
I/O	-	-	P235	P6	C22	H6	B28	203
I/O	P156	P201	P236	P5	B24	C3	D27	206
I/O	P157	P202	P237	P4	C23	D2	B29	209
I/O (A14)	P158	P203	P238	P3	D22	E5	C28	212
I/O, GCK8 (A15)	P159	P204	P239	P2	C24	G7	D28	215
VCC	P160	P205	P240	P1	VCC*	VCC*	VCC*	-
GND	P1	P2	P1	P304	GND*	GND*	GND*	-
I/O, GCK1 (A16)	P2	P4	P2	P303	D23	H8	D29	218
I/O (A17)	P3	P5	P3	P302	C25	F6	C30	221
I/O	P4	P6	P4	P301	D24	B4	E28	224
I/O	P5	P7	P5	P300	E23	D4	E29	227
I/O, TDI	P6	P8	P6	P299	C26	B2	D30	230
I/O, TCK	P7	P9	P7	P298	E24	G9	D31	233
I/O	-	-	-	-	D25	F8	E30	236
I/O	-	-	-	-	F23	C5	E31	239
I/O	-	-	-	P297	F24	A7	G28	242
I/O	-	-	-	P296	E25	A5	G29	245
VCC	-	-	-	-	VCC*	VCC*	VCC*	-
GND	-	-	-	-	GND*	GND*	GND*	-
I/O	P8	P10	P8	P295	D26	B8	H28	248
I/O	P9	P11	P9	P294	G24	C9	H29	251
I/O	-	P12	P10	P293	F25	E9	G30	254

XC4036EX/XL Pad Name	PQ 160††	HQ 208††	HQ 240	HQ 304	BG 352	PG 411	BG 432	Bndry Scan
I/O	-	P13	P11	P292	F26	F12	H30	257
I/O	-	-	P12	P291	H23	D10	J28	260
I/O	-	-	P13	P290	H24	B10	J29	263
I/O	-	-	-	P289	G25	F10	H31	266
I/O	-	-	-	P288	G26	F14	J30	269
GND	P10	P14	P14	P287	GND*	GND*	GND*	-
I/O	P11	P15	P15	P286	J23	C11	K28	272
I/O	P12	P16	P16	P285	J24	B12	K29	275
I/O, TMS	P13	P17	P17	P284	H25	E11	K30	278
I/O	P14	P18	P18	P283	K23	E15	K31	281
VCC	-	-	P19	P282	VCC*	VCC*	VCC*	-
I/O	-	-	P20	P280	K24	F16	L29	284
I/O	-	-	P21	P279	J25	C13	L30	287
I/O	-	-	-	-	J26	B14	M29	290
I/O	-	-	-	-	L23	E17	M31	293
I/O	-	-	-	P278	L24	E13	N31	296
I/O	-	-	-	P277	K25	A15	N28	299
GND	-	-	P22	-	GND*	GND*	GND*	-
VCC	-	-	-	-	VCC*	VCC*	VCC*	-
I/O	-	-	-	P276	L25	B16	P30	302
I/O	-	-	-	P275	L26	D16	P28	305
I/O	-	P19	P23	P274	M23	D18	P29	308
I/O	-	P20	P24	P273	M24	A17	R31	311
I/O	P15	P21	P25	P272	M25	E19	R30	314
I/O	P16	P22	P26	P271	M26	B18	R28	317
I/O	P17	P23	P27	P270	N24	C17	R29	320
I/O	P18	P24	P28	P269	N25	C19	T31	323
GND	P19	P25	P29	P268	GND*	GND*	GND*	-
VCC	P20	P26	P30	P267	VCC*	VCC*	VCC*	-
I/O	P21	P27	P31	P266	N26	F20	T30	326
I/O	P22	P28	P32	P265	P25	B20	T29	329
I/O	P23	P29	P33	P264	P23	C21	U31	332
I/O	P24	P30	P34	P263	P24	B22	U30	335
I/O	-	P31	P35	P262	R26	E21	U28	338
I/O	-	P32	P36	P261	R25	D22	U29	341
I/O	-	-	-	P260	R24	A23	V30	344
I/O	-	-	-	P259	R23	B24	V29	347
VCC	-	-	-	-	VCC*	VCC*	VCC*	-
GND	-	-	P37	-	GND*	GND*	GND*	-
I/O	-	-	-	P258	T26	A25	W30	350
I/O	-	-	-	P257	T25	D24	W29	353
I/O	-	-	-	-	T24	B26	Y30	356
I/O	-	-	-	-	U25	A27	Y29	359
I/O	-	-	P38	P256	T23	C27	Y28	362
I/O	-	-	P39	P255	V26	F24	AA30	365
VCC	-	-	P40	P253	VCC*	VCC*	VCC*	-
I/O	P25	P33	P41	P252	U24	E25	AA29	368
I/O	P26	P34	P42	P251	V25	E27	AB31	371
I/O	P27	P35	P43	P250	V24	B28	AB30	374
I/O	P28	P36	P44	P249	U23	C29	AB29	377
GND	P29	P37	P45	P248	GND*	GND*	GND*	-
I/O	-	-	-	P247	Y26	F26	AB28	380
I/O	-	-	-	P246	W25	D28	AC30	383
I/O	-	-	P46	P245	W24	B30	AC29	386
I/O	-	-	P47	P244	V23	E29	AC28	389
I/O	-	P38	P48	P243	AA26	F28	AD29	392
I/O	-	P39	P49	P242	Y25	F30	AD28	395
I/O	P30	P40	P50	P241	Y24	C31	AE30	398
I/O	P31	P41	P51	P240	AA25	E31	AE29	401
GND	-	-	-	-	GND*	GND*	GND*	-
VCC	-	-	-	-	VCC*	VCC*	VCC*	-
I/O	-	-	-	P239	AB25	B32	AF31	404
I/O	-	-	-	P238	AA24	A33	AE28	407
I/O	P32	P42	P52	P237	Y23	A35	AG31	410
I/O	P33	P43	P53	P236	AC26	F32	AF28	413
I/O	-	-	-	-	AD26	C35	AG30	416
I/O	-	-	-	-	AC25	B38	AG29	419
I/O	P34	P44	P54	P235	AA23	E33	AH31	422
I/O	P35	P45	P55	P234	AB24	G31	AG28	425
I/O	P36	P46	P56	P233	AD25	H32	AH30	428
I/O, GCK2	P37	P47	P57	P232	AC24	B36	AJ30	431
O (M1)	P38	P48	P58	P231	AB23	A39	AH29	434
GND	P39	P49	P59	P230	GND*	GND*	GND*	-
I (M0)	P40	P50	P60	P229	AD24	E35	AH28	437
VCC	P41	P55	P61	P228	VCC*	VCC*	VCC*	-

XC4036EX/XL Pad Name	PQ 160††	HQ 208††	HQ 240	HQ 304	BG 352	PG 411	BG 432	Bndry Scan	
I (M2)	P42	P56	P62	P227	AC23	G33	AJ28	438	
I/O, GCK3	P43	P57	P63	P226	AE24	D36	AK29	439	
I/O (HDC)	P44	P58	P64	P225	AD23	C37	AH27	442	
I/O	P45	P59	P65	P224	AC22	F34	AK28	445	
I/O	P46	P60	P66	P223	AF24	J33	AJ27	448	
I/O	P47	P61	P67	P222	AD22	D38	AL28	451	
I/O (LDC)	P48	P62	P68	P221	AE23	G35	AH26	454	
I/O	-	-	-	-	AC21	E39	AL27	457	
I/O	-	-	-	-	AD21	K34	AH25	460	
I/O	-	-	-	P220	AE22	F38	AK26	463	
I/O	-	-	-	P219	AF23	G37	AL26	466	
VCC	-	-	-	-	VCC*	VCC*	VCC*	-	
GND	-	-	-	-	GND*	GND*	GND*	-	
I/O	P49	P63	P69	P218	AD20	H38	AH24	469	
I/O	P50	P64	P70	P217	AE21	J37	AJ25	472	
I/O	-	P65	P71	P216	AF21	G39	AK25	475	
I/O	-	P66	P72	P215	AC19	M34	AJ24	478	
I/O	-	-	P73	P214	AD19	N35	AL24	481	
I/O	-	-	P74	P213	AE20	P34	AH22	484	
I/O	-	-	-	P212	AF20	J35	AJ23	487	
I/O	-	-	-	P211	AC18	L37	AK23	490	
GND	P51	P67	P75	P210	GND*	GND*	GND*	-	
I/O	P52	P68	P76	P209	AD18	M38	AJ22	493	
I/O	P53	P69	P77	P208	AE19	R35	AK22	496	
I/O	P54	P70	P78	P207	AC17	H36	AL22	499	
I/O	P55	P71	P79	P206	AD17	T34	AJ21	502	
VCC	-	-	P80	P204	VCC*	VCC*	VCC*	-	
I/O	-	P72	P81	P203	AE18	N37	AH20	505	
I/O	-	P73	P82	P202	AF18	N39	AK21	508	
I/O	-	-	-	-	AC16	U35	AK20	511	
I/O	-	-	-	-	AD16	R39	AJ19	514	
I/O	-	-	-	P201	AE17	M36	AL20	517	
I/O	-	-	-	P200	AE16	V34	AH18	520	
GND	-	-	P83	-	GND*	GND*	GND*	-	
VCC	-	-	-	-	VCC*	VCC*	VCC*	-	
I/O	-	-	-	P199	AF16	R37	AK19	523	
I/O	-	-	-	P198	AC15	T38	AJ18	526	
I/O	-	-	P84	P197	AD15	T36	AL19	529	
I/O	-	-	P85	P196	AE15	V36	AK18	532	
I/O	P56	P74	P86	P195	AF15	U37	AH17	535	
I/O	P57	P75	P87	P194	AD14	U39	AJ17	538	
I/O	P58	P76	P88	P193	AE14	V38	AJ16	541	
I/O (INIT)	P59	P77	P89	P192	AF14	W37	AK16	544	
VCC	P60	P78	P90	P191	VCC*	VCC*	VCC*	-	
GND	P61	P79	P91	P190	GND*	GND*	GND*	-	
I/O	P62	P80	P92	P189	AE13	Y34	AL16	547	
I/O	P63	P81	P93	P188	AC13	AC37	AH15	550	
I/O	P64	P82	P94	P187	AD13	AB38	AK15	553	
I/O	P65	P83	P95	P186	AF12	AD36	AJ14	556	
I/O	-	P84	P96	P185	AE12	AA35	AH14	559	
I/O	-	P85	P97	P184	AD12	AE37	AK14	562	
I/O	-	-	-	-	P183	AC12	AB36	AL13	565
I/O	-	-	-	-	P182	AF11	AD38	AK13	568
VCC	-	-	-	-	VCC*	VCC*	VCC*	-	
GND	-	-	P98	-	GND*	GND*	GND*	-	
I/O	-	-	-	P181	AE11	AB34	AJ13	571	
I/O	-	-	-	P180	AD11	AE39	AH13	574	
I/O	-	-	-	-	AE10	AM36	AL12	577	
I/O	-	-	-	-	AC11	AC35	AK12	580	
I/O	-	-	P99	P179	AF9	AG39	AH12	583	
I/O	-	-	P100	P178	AD10	AG37	AJ11	586	
VCC	-	-	P101	P177	VCC*	VCC*	VCC*	-	
I/O	P66	P86	P102	P175	AE9	AD34	AL10	589	
I/O	P67	P87	P103	P174	AD9	AN39	AK10	592	
I/O	P68	P88	P104	P173	AC10	AE35	AJ10	595	
I/O	P69	P89	P105	P172	AF7	AH38	AK9	598	
GND	P70	P90	P106	P171	GND*	GND*	GND*	-	
I/O	-	-	-	P170	AE8	AJ37	AL8	601	
I/O	-	-	-	P169	AD8	AG35	AH10	604	
I/O	-	-	P107	P168	AC9	AF34	AJ9	607	
I/O	-	-	P108	P167	AF6	AH36	AK8	610	
I/O	-	P91	P109	P166	AE7	AK36	AK7	613	
I/O	-	P92	P110	P165	AD7	AM34	AL6	616	
I/O	P71	P93	P111	P164	AE6	AH34	AJ7	619	
I/O	P72	P94	P112	P163	AE5	AJ35	AH8	622	

XC4000E and XC4000X Series Field Programmable Gate Arrays

XC4036EX/XL Pad Name	PQ 160††	HQ 208††	HQ 240	HQ 304	BG 352	PG 411	BG 432	Bndry Scan
GND	-	-	-	-	GND*	GND*	GND*	-
VCC	-	-	-	-	VCC*	VCC*	VCC*	-
I/O	-	-	-	P162	AD6	AL37	AK6	625
I/O	-	-	-	P161	AC7	AT38	AL5	628
I/O	P73	P95	P113	P160	AF4	AM38	AH7	631
I/O	P74	P96	P114	P159	AF3	AN37	AJ6	634
I/O	-	-	-	-	AE4	AK34	AK5	637
I/O	-	-	-	-	AC6	AR39	AL4	640
I/O	P75	P97	P115	P158	AD5	AN35	AK4	643
I/O	P76	P98	P116	P157	AE3	AL33	AH5	646
I/O	P77	P99	P117	P156	AD4	AV38	AK3	649
I/O, GCK4	P78	P100	P118	P155	AC5	AT36	AJ4	652
GND	P79	P101	P119	P154	GND*	GND*	GND*	-
DONE	P80	P103	P120	P153	AD3	AR35	AH4	-
VCC	P81	P106	P121	P152	VCC*	VCC*	VCC*	-
PROGRAM	P82	P108	P122	P151	AC4	AN33	AH3	-
I/O (D7)	P83	P109	P123	P150	AD2	AM32	AJ2	655
I/O, GCK5	P84	P110	P124	P149	AC3	AP34	AG4	658
I/O	P85	P111	P125	P148	AB4	AW39	AG3	661
I/O	P86	P112	P126	P147	AD1	AN31	AH2	664
I/O	-	-	-	-	AB3	AV36	AH1	667
I/O	-	-	-	-	AC2	AR33	AF4	670
I/O	-	-	P127	P146	AA4	AP32	AF3	673
I/O	-	-	P128	P145	AA3	AU35	AG2	676
I/O	-	-	-	P144	AB2	AW33	AE3	679
I/O	-	-	-	P143	AC1	AU33	AF2	682
VCC	-	-	-	-	VCC*	VCC*	VCC*	-
GND	-	-	-	-	GND*	GND*	GND*	-
I/O (D6)	P87	P113	P129	P142	Y3	AV32	AF1	685
I/O	P88	P114	P130	P141	AA2	AU31	AD4	688
I/O	P89	P115	P131	P140	AA1	AR31	AD3	691
I/O	P90	P116	P132	P139	W4	AP28	AE2	694
I/O	-	P117	P133	P138	W3	AT32	AC3	697
I/O	-	P118	P134	P137	Y2	AV30	AD1	700
I/O	-	-	-	P136	Y1	AR29	AC2	703
I/O	-	-	-	P135	V4	AP26	AB4	706
GND	P91	P119	P135	P134	GND*	GND*	GND*	-
I/O	-	-	P136	P133	V3	AU29	AB3	709
I/O	-	-	P137	P132	W2	AV28	AB2	712
I/O	P92	P120	P138	P131	U4	AT28	AB1	715
I/O	P93	P121	P139	P130	U3	AR25	AA3	718
VCC	-	-	P140	P129	VCC*	VCC*	VCC*	-
I/O (D5)	P94	P122	P141	P127	V2	AP24	AA2	721
I/O (CS0)	P95	P123	P142	P126	V1	AU27	Y2	724
I/O	-	-	-	-	T4	AR27	Y4	727
I/O	-	-	-	-	T3	AW27	Y3	730
I/O	-	-	-	P125	U2	AT24	W4	733
I/O	-	-	-	P124	T2	AR23	W3	736
GND	-	-	P143	-	GND*	GND*	GND*	-
VCC	-	-	-	-	VCC*	VCC*	VCC*	-
I/O	-	-	-	P123	T1	AP22	V4	739
I/O	-	-	-	P122	R4	AV24	V3	742
I/O	-	P124	P144	P121	R3	AU23	U1	745
I/O	-	P125	P145	P120	R2	AT22	U2	748
I/O	P96	P126	P146	P119	R1	AR21	U4	751
I/O	P97	P127	P147	P118	P3	AV22	U3	754
I/O (D4)	P98	P128	P148	P117	P2	AP20	T1	757
I/O	P99	P129	P149	P116	P1	AU21	T2	760
VCC	P100	P130	P150	P115	VCC*	VCC*	VCC*	-
GND	P101	P131	P151	P114	GND*	GND*	GND*	-
I/O (D3)	P102	P132	P152	P113	N2	AU19	T3	763
I/O (RS)	P103	P133	P153	P112	N4	AV20	R1	766
I/O	P104	P134	P154	P111	N3	AV18	R2	769
I/O	P105	P135	P155	P110	M1	AR19	R4	772
I/O	-	P136	P156	P109	M2	AT18	R3	775
I/O	-	P137	P157	P108	M3	AW17	P2	778
I/O	-	-	-	P107	M4	AV16	P3	781
I/O	-	-	-	P106	L1	AP18	P4	784
VCC	-	-	-	-	VCC*	VCC*	VCC*	-
GND	-	-	P158	-	GND*	GND*	GND*	-
I/O	-	-	-	P105	L2	AR17	N3	787
I/O	-	-	-	P104	L3	AT16	N4	790
I/O	-	-	-	-	K2	AV14	M1	793
I/O	-	-	-	-	L4	AW13	M2	796
I/O (D2)	P106	P138	P159	P103	J1	AR15	L2	799

XC4036EX/XL Pad Name	PQ 160††	HQ 208††	HQ 240	HQ 304	BG 352	PG 411	BG 432	Bndry Scan
I/O	P107	P139	P160	P102	K3	AP16	L3	802
VCC	-	-	P161	P101	VCC*	VCC*	VCC*	-
I/O	P108	P140	P162	P99	J2	AV12	K1	805
I/O	P109	P141	P163	P98	J3	AR13	K2	808
I/O	-	-	P164	P97	K4	AU11	K3	811
I/O	-	-	P165	P96	G1	AT12	K4	814
GND	P110	P142	P166	P95	GND*	GND*	GND*	-
I/O	-	-	-	P94	H2	AP14	J2	817
I/O	-	-	-	P93	H3	AR11	J3	820
I/O	-	-	P167	P92	J4	AV10	H4	823
I/O	-	-	P168	P91	F1	AT8	H1	826
I/O	-	P143	P169	P90	G2	AT10	H2	829
I/O	-	P144	P170	P89	G3	AP10	H3	832
I/O	P111	P145	P171	P88	F2	AP12	H4	835
I/O	P112	P146	P172	P87	E2	AR9	G2	838
GND	-	-	-	-	GND*	GND*	GND*	-
VCC	-	-	-	-	VCC*	VCC*	VCC*	-
I/O (D1)	P113	P147	P173	P86	F3	AU7	G4	841
I/O (RCLK, RDY/ BUSY)	P114	P148	P174	P85	G4	AW7	F2	844
I/O	-	-	-	-	D1	AW5	F3	847
I/O	-	-	-	-	C1	AV6	E1	850
I/O	-	-	-	P84	D2	AR7	E3	853
I/O	-	-	-	P83	F4	AV4	D1	856
I/O	P115	P149	P175	P82	E3	AN9	E4	859
I/O	P116	P150	P176	P81	C2	AW1	D2	862
I/O (D0, DIN)	P117	P151	P177	P80	D3	AP6	C2	865
I/O, GCK6 (DOUT)	P118	P152	P178	P79	E4	AU3	D3	868
CCLK	P119	P153	P179	P78	C3	AR5	D4	-
VCC	P120	P154	P180	P77	VCC*	VCC*	VCC*	-
O, TDO	P121	P159	P181	P76	D4	AN7	C4	0
GND	P122	P160	P182	P75	GND*	GND*	GND*	-
I/O (A0, WS)	P123	P161	P183	P74	B3	AT4	B3	2
I/O, GCK7 (A1)	P124	P162	P184	P73	C4	AV2	D5	5
I/O	P125	P163	P185	P72	D5	AM8	B4	8
I/O	P126	P164	P186	P71	A3	AL7	C5	11
I/O	-	-	-	-	C5	AR3	B5	14
I/O	-	-	-	-	B4	AR1	C6	17
I/O (CS1, A2)	P127	P165	P187	P70	D6	AK6	A5	20
I/O (A3)	P128	P166	P188	P69	C6	AN3	D7	23
I/O	-	-	-	P68	B5	AM6	B6	26
I/O	-	-	-	P67	A4	AM2	A6	29
VCC	-	-	-	-	VCC*	VCC*	VCC*	-
GND	-	-	-	-	GND*	GND*	GND*	-
I/O	-	-	P189	P66	C7	AL3	D8	32
I/O	-	-	P190	P65	B6	AH6	C7	35
I/O	P129	P167	P191	P64	A6	AP2	B7	38
I/O	P130	P168	P192	P63	D8	AK4	D9	41
I/O	-	P169	P193	P62	B7	AG5	D10	44
I/O	-	P170	P194	P61	A7	AF6	C9	47
I/O	-	-	P195	P60	D9	AL5	B9	50
I/O	-	-	-	P59	C9	AJ3	C10	53
GND	P131	P171	P196	P58	GND*	GND*	GND*	-
I/O	P132	P172	P197	P57	B8	AH2	B10	56
I/O	P133	P173	P198	P56	D10	AE5	A10	59
I/O	-	-	P199	P55	C10	AM4	C11	62
I/O	-	-	P200	P54	B9	AD6	D12	65
VCC	-	-	P201	P52	VCC*	VCC*	VCC*	-
I/O	-	-	-	P51	A9	AG3	B11	68
I/O	-	-	-	P50	D11	AG1	C12	71
I/O	-	-	-	-	C11	AC5	C13	74
I/O	-	-	-	-	B10	AE1	A12	77
I/O	-	-	-	P49	B11	AH4	D14	80
I/O	-	-	-	P48	A11	AB6	B13	83
GND	-	-	-	-	GND*	GND*	GND*	-
VCC	-	-	-	-	VCC*	VCC*	VCC*	-
I/O (A4)	P134	P174	P202	P47	D12	AD2	C14	86
I/O (A5)	P135	P175	P203	P46	C12	AB4	A13	89
I/O	-	P176	P205	P45	B12	AE3	B14	92
I/O	P136	P177	P206	P44	A12	AC1	D15	95
I/O (A21)	P137	P178	P207	P43	C13	AD4	C15	98
I/O (A20)	P138	P179	P208	P42	B13	AA5	B15	101
I/O (A6)	P139	P180	P209	P41	A13	AA3	B16	104
I/O (A7)	P140	P181	P210	P40	B14	Y6	A16	107

XC4036EX/XL Pad Name	PQ 160††	HQ 208††	HQ 240	HQ 304	BG 352	PG 411	BG 432	Bdry Scan
GND	P141	P182	P211	P39	GND*	GND*	GND*	-

6/17/97

* Pads labelled GND* or VCC* are internally bonded to Ground or VCC planes within the associated package. They have no direct connection to any specific package pin.

†† = XL only

Additional XC4036EX/XL Package Pins

HQ208

N.C. Pins				
P1	P3	P51	P52	P53
P54	P102	P104	P105	P107
P155	P156	P157	P158	P206
P207	P208	-	-	-

5/15/97

HQ240

GND Pins				
P204	P219	-	-	-

6/17/97

The Ground (GND) package pins in the above table should be externally connected to Ground if possible; however, they can be left unconnected if necessary for compatibility with other devices.

HQ304

N.C. Pins				
P11	P24	P53	P100	P128
P176	P205	P254	P281	-

5/15/97

BG352

VCC Pins					
A10	A17	B2	B25	D7	D13
D19	G23	H4	K1	K26	N23
P4	U1	U26	W23	Y4	AC8
AC14	AC20	AE2	AE25	AF10	AF17
GND Pins					
A1	A2	A5	A8	A14	A19
A22	A25	A26	B1	B26	E1
E26	H1	H26	N1	P26	W1
W26	AB1	AB26	AE1	AE26	AF1
AF2	AF5	AF8	AF13	AF19	AF22
AF25	AF26	-	-	-	-
N.C. Pins					
C8	-	-	-	-	-

6/16/97

PG411

VCC Pins					
A3	A11	A21	A31	C39	D6
F36	J1	L39	W1	AA39	AJ1
AL39	AP4	AT34	AU1	AW9	AW19
AW29	AW37	-	-	-	-
GND Pins					
A9	A19	A29	A37	C1	D14
D20	D26	D34	F4	J39	L1
P4	P36	W39	Y4	Y36	AA1
AF4	AF36	AJ39	AL1	AP36	AT6
AT14	AT20	AT26	AU39	AW3	AW11
AW21	AW31	-	-	-	-
N.C. Pins					
A13	B6	B34	C7	C15	C23
C25	C33	D8	D12	D30	D32
E7	E23	E37	F2	F18	F22
G5	H34	J5	K36	K38	L5
L35	N3	P38	R3	V2	W5
W35	Y38	AA37	AB2	AC3	AC39
AF2	AF38	AJ5	AK2	AK38	AL35
AN1	AN5	AP8	AP30	AP38	AR37
AT2	AT30	AU5	AU9	AU13	AU15
AU17	AU25	AU37	AV8	AV26	AV34
AW15	AW23	AW25	AW35	-	-

6/16/97

BG432

VCC Pins					
A1	A11	A21	A31	C3	C29
D11	D21	L1	L4	L28	L31
AA1	AA4	AA28	AA31	AH11	AH21
AJ3	AJ29	AL1	AL11	AL21	AL31
GND Pins					
A2	A3	A7	A9	A14	A18
A23	A25	A29	A30	B1	B2
B30	B31	C1	C31	D16	G1
G31	J1	J31	P1	P31	T4
T28	V1	V31	AC1	AC31	AE1
AE31	AH16	AJ1	AJ31	AK1	AK2
AK30	AK31	AL2	AL3	AL7	AL9
AL14	AL18	AL23	AL25	AL29	AL30
N.C. Pins					
A4	A8	A15	A28	B8	B12
B17	B21	B25	C8	C16	C17
D6	D13	D20	D23	D26	E2
F1	F4	F28	F29	F30	F31
G3	M3	M4	M28	M30	N1
N2	N29	N30	V2	V28	W1
W2	W28	W31	Y1	Y31	AC4
AD2	AD30	AD31	AE4	AF29	AF30
AG1	AH6	AH9	AH19	AH23	AJ5
AJ8	AJ12	AJ15	AJ20	AJ26	AK11
AK17	AK24	AK27	AL15	AL17	-

5/15/97

Pin Locations for XC4044XL Devices

(Note: XC4044XL is also available in the HQ304 package. The pinout is identical to the XC4036XL in the HQ304.)

XC4044XL Pad Name	HQ 160	HQ 208	HQ 240	BG 352	PG 411	BG 432
VCC	P142	P183	P212	VCC*	VCC*	VCC*
I/O (A8)	P143	P184	P213	D14	W3	D17
I/O (A9)	P144	P185	P214	C14	Y2	A17
I/O	-	-	-	-	V2	C17
I/O	-	-	-	-	W5	B17
I/O (A19)	P145	P186	P215	A15	V4	C18

XC4044XL Pad Name	HQ 160	HQ 208	HQ 240	BG 352	PG 411	BG 432
I/O (A18)	P146	P187	P216	B15	T2	D18
I/O	-	P188	P217	C15	U1	B18
I/O	-	P189	P218	D15	V6	A19
I/O (A10)	P147	P190	P220	A16	U3	B19
I/O (A11)	P148	P191	P221	B16	R1	C19
VCC	-	-	-	VCC*	VCC*	VCC*
GND	-	-	-	GND*	GND*	GND*
I/O	-	-	-	C16	U5	D19
I/O	-	-	-	B17	T4	A20

XC4000E and XC4000X Series Field Programmable Gate Arrays

XC4044XL Pad Name	HQ 160	HQ 208	HQ 240	BG 352	PG 411	BG 432
I/O	-	-	-	D16	P2	B20
I/O	-	-	-	A18	N1	C20
I/O	-	-	-	C17	R5	C21
I/O	-	-	-	B18	M2	A22
VCC	-	-	P222	VCC*	VCC*	VCC*
I/O	-	-	P223	C18	L3	B22
I/O	-	-	P224	D17	T6	C22
I/O	P149	P192	P225	A20	N5	B23
I/O	P150	P193	P226	B19	M4	A24
GND	P151	P194	P227	GND*	GND*	GND*
I/O	-	-	-	C19	K2	D22
I/O	-	-	-	D18	K4	C23
I/O	-	P195	P228	A21	P6	B24
I/O	-	P196	P229	B20	M6	C24
I/O	-	-	-	-	L5	D23
I/O	-	-	-	-	J5	B25
I/O	P152	P197	P230	C20	J3	A26
I/O	P153	P198	P231	B21	H2	C25
I/O (A12)	P154	P199	P232	B22	H4	D24
I/O (A13)	P155	P200	P233	C21	G3	B26
GND	-	-	-	GND*	GND*	GND*
VCC	-	-	-	VCC*	VCC*	VCC*
I/O	-	-	-	D20	K6	A27
I/O	-	-	-	A23	G1	D25
I/O	-	-	-	A24	E1	C26
I/O	-	-	-	B23	E3	B27
I/O	-	-	P234	D21	J7	C27
I/O	-	-	P235	C22	H6	B28
I/O	P156	P201	P236	B24	C3	D27
I/O	P157	P202	P237	C23	D2	B29
I/O (A14)	P158	P203	P238	D22	E5	C28
I/O, GCK8 (A15)	P159	P204	P239	C24	G7	D28
VCC	P160	P205	P240	VCC*	VCC*	VCC*
GND	P1	P2	P1	GND*	GND*	GND*
I/O, GCK1 (A16)	P2	P4	P2	D23	H8	D29
I/O (A17)	P3	P5	P3	C25	F6	C30
I/O	P4	P6	P4	D24	B4	E28
I/O	P5	P7	P5	E23	D4	E29
I/O, TDI	P6	P8	P6	C26	B2	D30
I/O, TCK	P7	P9	P7	E24	G9	D31
I/O	-	-	-	D25	F8	E30
I/O	-	-	-	F23	C5	E31
I/O	-	-	-	F24	A7	G28
I/O	-	-	-	E25	A5	G29
VCC	-	-	-	VCC*	VCC*	VCC*
GND	-	-	-	GND*	GND*	GND*
I/O	-	-	-	-	C7	F30
I/O	-	-	-	-	D8	F31
I/O	P8	P10	P8	D26	B8	H28
I/O	P9	P11	P9	G24	C9	H29
I/O	-	P12	P10	F25	E9	G30
I/O	-	P13	P11	F26	F12	H30
I/O	-	-	P12	H23	D10	J28
I/O	-	-	P13	H24	B10	J29
I/O	-	-	-	G25	F10	H31
I/O	-	-	-	G26	F14	J30
GND	P10	P14	P14	GND*	GND*	GND*
I/O	P11	P15	P15	J23	C11	K28
I/O	P12	P16	P16	J24	B12	K29
I/O, TMS	P13	P17	P17	H25	E11	K30
I/O	P14	P18	P18	K23	E15	K31
VCC	-	-	P19	VCC*	VCC*	VCC*
I/O	-	-	P20	K24	F16	L29
I/O	-	-	P21	J25	C13	L30
I/O	-	-	-	J26	B14	M29
I/O	-	-	-	L23	E17	M31
I/O	-	-	-	L24	E13	N31
I/O	-	-	-	K25	A15	N28
GND	-	-	P22	GND*	GND*	GND*
VCC	-	-	-	VCC*	VCC*	VCC*
I/O	-	-	-	-	F18	N29
I/O	-	-	-	-	C15	N30
I/O	-	-	-	L25	B16	P30
I/O	-	-	-	L26	D16	P28
I/O	-	P19	P23	M23	D18	P29

XC4044XL Pad Name	HQ 160	HQ 208	HQ 240	BG 352	PG 411	BG 432
I/O	-	P20	P24	M24	A17	R31
I/O	P15	P21	P25	M25	E19	R30
I/O	P16	P22	P26	M26	B18	R28
I/O	P17	P23	P27	N24	C17	R29
I/O	P18	P24	P28	N25	C19	T31
GND	P19	P25	P29	GND*	GND*	GND*
VCC	P20	P26	P30	VCC*	VCC*	VCC*
I/O	P21	P27	P31	N26	F20	T30
I/O	P22	P28	P32	P25	B20	T29
I/O	P23	P29	P33	P23	C21	U31
I/O	P24	P30	P34	P24	B22	U30
I/O	-	P31	P35	R26	E21	U28
I/O	-	P32	P36	R25	D22	U29
I/O	-	-	-	R24	A23	V30
I/O	-	-	-	R23	B24	V29
I/O	-	-	-	-	C23	V28
I/O	-	-	-	-	F22	W31
VCC	-	-	-	VCC*	VCC*	VCC*
GND	-	-	P37	GND*	GND*	GND*
I/O	-	-	-	T26	A25	W30
I/O	-	-	-	T25	D24	W29
I/O	-	-	-	T24	B26	Y30
I/O	-	-	-	U25	A27	Y29
I/O	-	-	P38	T23	C27	Y28
I/O	-	-	P39	V26	F24	AA30
VCC	-	-	P40	VCC*	VCC*	VCC*
I/O	P25	P33	P41	U24	E25	AA29
I/O	P26	P34	P42	V25	E27	AB31
I/O	P27	P35	P43	V24	B28	AB30
I/O	P28	P36	P44	U23	C29	AB29
GND	P29	P37	P45	GND*	GND*	GND*
I/O	-	-	-	Y26	F26	AB28
I/O	-	-	-	W25	D28	AC30
I/O	-	-	P46	W24	B30	AC29
I/O	-	-	P47	V23	E29	AC28
I/O	-	-	-	-	D30	AD31
I/O	-	-	-	-	D32	AD30
I/O	-	P38	P48	AA26	F28	AD29
I/O	-	P39	P49	Y25	F30	AD28
I/O	P30	P40	P50	Y24	C31	AE30
I/O	P31	P41	P51	AA25	E31	AE29
GND	-	-	-	GND*	GND*	GND*
VCC	-	-	-	VCC*	VCC*	VCC*
I/O	-	-	-	AB25	B32	AF31
I/O	-	-	-	AA24	A33	AE28
I/O	P32	P42	P52	Y23	A35	AG31
I/O	P33	P43	P53	AC26	F32	AF28
I/O	-	-	-	AD26	C35	AG30
I/O	-	-	-	AC25	B38	AG29
I/O	P34	P44	P54	AA23	E33	AH31
I/O	P35	P45	P55	AB24	G31	AG28
I/O	P36	P46	P56	AD25	H32	AH30
I/O, GCK2	P37	P47	P57	AC24	B36	AJ30
O (M1)	P38	P48	P58	AB23	A39	AH29
GND	P39	P49	P59	GND*	GND*	GND*
I (M0)	P40	P50	P60	AD24	E35	AH28
VCC	P41	P55	P61	VCC*	VCC*	VCC*
I (M2)	P42	P56	P62	AC23	G33	AJ28
I/O, GCK3	P43	P57	P63	AE24	D36	AK29
I/O (HDC)	P44	P58	P64	AD23	C37	AH27
I/O	P45	P59	P65	AC22	F34	AK28
I/O	P46	P60	P66	AF24	J33	AJ27
I/O	P47	P61	P67	AD22	D38	AL28
I/O (LDC)	P48	P62	P68	AE23	G35	AH26
I/O	-	-	-	AC21	E39	AL27
I/O	-	-	-	AD21	K34	AH25
I/O	-	-	-	AE22	F38	AK26
I/O	-	-	-	AF23	G37	AL26
VCC	-	-	-	VCC*	VCC*	VCC*
GND	-	-	-	GND*	GND*	GND*
I/O	P49	P63	P69	AD20	H38	AH24
I/O	P50	P64	P70	AE21	J37	AJ25
I/O	-	P65	P71	AF21	G39	AK25
I/O	-	P66	P72	AC19	M34	AJ24
I/O	-	-	-	-	K36	AH23

XC4044XL Pad Name	HQ 160	HQ 208	HQ 240	BG 352	PG 411	BG 432
I/O	-	-	-	-	K38	AK24
I/O	-	-	P73	AD19	N35	AL24
I/O	-	-	P74	AE20	P34	AH22
I/O	-	-	-	AF20	J35	AJ23
I/O	-	-	-	AC18	L37	AK23
GND	P51	P67	P75	GND*	GND*	GND*
I/O	P52	P68	P76	AD18	M38	AJ22
I/O	P53	P69	P77	AE19	R35	AK22
I/O	P54	P70	P78	AC17	H36	AL22
I/O	P55	P71	P79	AD17	T34	AJ21
VCC	-	-	P80	VCC*	VCC*	VCC*
I/O	-	P72	P81	AE18	N37	AH20
I/O	-	P73	P82	AF18	N39	AK21
I/O	-	-	-	AC16	U35	AK20
I/O	-	-	-	AD16	R39	AJ19
I/O	-	-	-	AE17	M36	AL20
I/O	-	-	-	AE16	V34	AH18
GND	-	-	P83	GND*	GND*	GND*
VCC	-	-	-	VCC*	VCC*	VCC*
I/O	-	-	-	AF16	R37	AK19
I/O	-	-	-	AC15	T38	AJ18
I/O	-	-	P84	AD15	T36	AL19
I/O	-	-	P85	AE15	V36	AK18
I/O	P56	P74	P86	AF15	U37	AH17
I/O	P57	P75	P87	AD14	U39	AJ17
I/O	-	-	-	-	W35	AK17
I/O	-	-	-	-	AC39	AL17
I/O	P58	P76	P88	AE14	V38	AJ16
I/O (INIT)	P59	P77	P89	AF14	W37	AK16
VCC	P60	P78	P90	VCC*	VCC*	VCC*
GND	P61	P79	P91	GND*	GND*	GND*
I/O	P62	P80	P92	AE13	Y34	AL16
I/O	P63	P81	P93	AC13	AC37	AH15
I/O	-	-	-	-	Y38	AL15
I/O	-	-	-	-	AA37	AJ15
I/O	P64	P82	P94	AD13	AB38	AK15
I/O	P65	P83	P95	AF12	AD36	AJ14
I/O	-	P84	P96	AE12	AA35	AH14
I/O	-	P85	P97	AD12	AE37	AK14
I/O	-	-	-	AC12	AB36	AL13
I/O	-	-	-	AF11	AD38	AK13
VCC	-	-	-	VCC*	VCC*	VCC*
GND	-	-	P98	GND*	GND*	GND*
I/O	-	-	-	AE11	AB34	AJ13
I/O	-	-	-	AD11	AE39	AH13
I/O	-	-	-	AE10	AM36	AL12
I/O	-	-	-	AC11	AC35	AK12
I/O	-	-	P99	AF9	AG39	AH12
I/O	-	-	P100	AD10	AG37	AJ11
VCC	-	-	P101	VCC*	VCC*	VCC*
I/O	P66	P86	P102	AE9	AD34	AL10
I/O	P67	P87	P103	AD9	AN39	AK10
I/O	P68	P88	P104	AC10	AE35	AJ10
I/O	P69	P89	P105	AF7	AH38	AK9
GND	P70	P90	P106	GND*	GND*	GND*
I/O	-	-	-	AE8	AJ37	AL8
I/O	-	-	-	AD8	AG35	AH10
I/O	-	-	P107	AC9	AF34	AJ9
I/O	-	-	P108	AF6	AH36	AK8
I/O	-	-	-	-	AK38	AJ8
I/O	-	-	-	-	AP38	AH9
I/O	-	P91	P109	AE7	AK36	AK7
I/O	-	P92	P110	AD7	AM34	AL6
I/O	P71	P93	P111	AE6	AH34	AJ7
I/O	P72	P94	P112	AE5	AJ35	AH8
GND	-	-	-	GND*	GND*	GND*
VCC	-	-	-	VCC*	VCC*	VCC*
I/O	-	-	-	AD6	AL37	AK6
I/O	-	-	-	AC7	AT38	AL5
I/O	P73	P95	P113	AF4	AM38	AH7
I/O	P74	P96	P114	AF3	AN37	AJ6
I/O	-	-	-	AE4	AK34	AK5
I/O	-	-	-	AC6	AR39	AL4
I/O	P75	P97	P115	AD5	AN35	AK4
I/O	P76	P98	P116	AE3	AL33	AH5

XC4044XL Pad Name	HQ 160	HQ 208	HQ 240	BG 352	PG 411	BG 432
I/O	P77	P99	P117	AD4	AV38	AK3
I/O, GCK4	P78	P100	P118	AC5	AT36	AJ4
GND	P79	P101	P119	GND*	GND*	GND*
DONE	P80	P103	P120	AD3	AR35	AH4
VCC	P81	P106	P121	VCC*	VCC*	VCC*
PROGRAM	P82	P108	P122	AC4	AN33	AH3
I/O (D7)	P83	P109	P123	AD2	AM32	AJ2
I/O, GCK5	P84	P110	P124	AC3	AP34	AG4
I/O	P85	P111	P125	AB4	AW39	AG3
I/O	P86	P112	P126	AD1	AN31	AH2
I/O	-	-	-	AB3	AV36	AH1
I/O	-	-	-	AC2	AR33	AF4
I/O	-	-	P127	AA4	AP32	AF3
I/O	-	-	P128	AA3	AU35	AG2
I/O	-	-	-	AB2	AW33	AE3
I/O	-	-	-	AC1	AU33	AF2
VCC	-	-	-	VCC*	VCC*	VCC*
GND	-	-	-	GND*	GND*	GND*
I/O (D6)	P87	P113	P129	Y3	AV32	AF1
I/O	P88	P114	P130	AA2	AU31	AD4
I/O	P89	P115	P131	AA1	AR31	AD3
I/O	P90	P116	P132	W4	AP28	AE2
I/O	-	-	-	-	AP30	AD2
I/O	-	-	-	-	AT30	AC4
I/O	-	P117	P133	W3	AT32	AC3
I/O	-	P118	P134	Y2	AV30	AD1
I/O	-	-	-	Y1	AR29	AC2
I/O	-	-	-	V4	AP26	AB4
GND	P91	P119	P135	GND*	GND*	GND*
I/O	-	-	P136	V3	AU29	AB3
I/O	-	-	P137	W2	AV28	AB2
I/O	P92	P120	P138	U4	AT28	AB1
I/O	P93	P121	P139	U3	AR25	AA3
VCC	-	-	P140	VCC*	VCC*	VCC*
I/O (D5)	P94	P122	P141	V2	AP24	AA2
I/O (CS0)	P95	P123	P142	V1	AU27	Y2
I/O	-	-	-	T4	AR27	Y4
I/O	-	-	-	T3	AW27	Y3
I/O	-	-	-	U2	AT24	W4
I/O	-	-	-	T2	AR23	W3
GND	-	-	P143	GND*	GND*	GND*
VCC	-	-	-	VCC*	VCC*	VCC*
I/O	-	-	-	-	AW25	W2
I/O	-	-	-	-	AW23	V2
I/O	-	-	-	T1	AP22	V4
I/O	-	-	-	R4	AV24	V3
I/O	-	P124	P144	R3	AU23	U1
I/O	-	P125	P145	R2	AT22	U2
I/O	P96	P126	P146	R1	AR21	U4
I/O	P97	P127	P147	P3	AV22	U3
I/O (D4)	P98	P128	P148	P2	AP20	T1
I/O	P99	P129	P149	P1	AU21	T2
VCC	P100	P130	P150	VCC*	VCC*	VCC*
GND	P101	P131	P151	GND*	GND*	GND*
I/O (D3)	P102	P132	P152	N2	AU19	T3
I/O (RS)	P103	P133	P153	N4	AV20	R1
I/O	P104	P134	P154	N3	AV18	R2
I/O	P105	P135	P155	M1	AR19	R4
I/O	-	P136	P156	M2	AT18	R3
I/O	-	P137	P157	M3	AW17	P2
I/O	-	-	-	M4	AV16	P3
I/O	-	-	-	L1	AP18	P4
I/O	-	-	-	-	AU17	N1
I/O	-	-	-	-	AW15	N2
VCC	-	-	-	VCC*	VCC*	VCC*
GND	-	-	P158	GND*	GND*	GND*
I/O	-	-	-	L2	AR17	N3
I/O	-	-	-	L3	AT16	N4
I/O	-	-	-	K2	AV14	M1
I/O	-	-	-	L4	AW13	M2
I/O (D2)	P106	P138	P159	J1	AR15	L2
I/O	P107	P139	P160	K3	AP16	L3
VCC	-	-	P161	VCC*	VCC*	VCC*
I/O	P108	P140	P162	J2	AV12	K1
I/O	P109	P141	P163	J3	AR13	K2

XC4044XL Pad Name	HQ 160	HQ 208	HQ 240	BG 352	PG 411	BG 432	
I/O	-	-	P164	K4	AU11	K3	
I/O	-	-	P165	G1	AT12	K4	
GND	P110	P142	P166	GND*	GND*	GND*	
I/O	-	-	-	H2	AP14	J2	
I/O	-	-	-	H3	AR11	J3	
I/O	-	-	P167	J4	AV10	J4	
I/O	-	-	-	P168	F1	AT8	H1
I/O	-	P143	P169	G2	AT10	H2	
I/O	-	P144	P170	G3	AP10	H3	
I/O	P111	P145	P171	F2	AP12	H4	
I/O	P112	P146	P172	E2	AR9	G2	
I/O	-	-	-	-	AU9	G3	
I/O	-	-	-	-	AV8	F1	
GND	-	-	-	GND*	GND*	GND*	
VCC	-	-	-	VCC*	VCC*	VCC*	
I/O (D1)	P113	P147	P173	F3	AU7	G4	
I/O (RCLK, RDY/BUSY)	P114	P148	P174	G4	AW7	F2	
I/O	-	-	-	D1	AW5	F3	
I/O	-	-	-	C1	AV6	E1	
I/O	-	-	-	D2	AR7	E3	
I/O	-	-	-	F4	AV4	D1	
I/O	P115	P149	P175	E3	AN9	E4	
I/O	P116	P150	P176	C2	AW1	D2	
I/O (D0, DIN)	P117	P151	P177	D3	AP6	C2	
I/O, GCK6 (DOOUT)	P118	P152	P178	E4	AU3	D3	
CCLK	P119	P153	P179	C3	AR5	D4	
VCC	P120	P154	P180	VCC*	VCC*	VCC*	
O, TDO	P121	P159	P181	D4	AN7	C4	
GND	P122	P160	P182	GND*	GND*	GND*	
I/O (A0, WS)	P123	P161	P183	B3	AT4	B3	
I/O, GCK7 (A1)	P124	P162	P184	C4	AV2	D5	
I/O	P125	P163	P185	D5	AM8	B4	
I/O	P126	P164	P186	A3	AL7	C5	
I/O	-	-	-	C5	AR3	B5	
I/O	-	-	-	B4	AR1	C6	
I/O (CS1,A2)	P127	P165	P187	D6	AK6	A5	
I/O (A3)	P128	P166	P188	C6	AN3	D7	
I/O	-	-	-	B5	AM6	B6	
I/O	-	-	-	A4	AM2	A6	
VCC	-	-	-	VCC*	VCC*	VCC*	
GND	-	-	-	GND*	GND*	GND*	
I/O	-	-	P189	C7	AL3	D8	
I/O	-	-	P190	B6	AH6	C7	
I/O	P129	P167	P191	A6	AP2	B7	
I/O	P130	P168	P192	D8	AK4	D9	
I/O	-	-	-	C8	AN1	B8	
I/O	-	-	-	-	AK2	A8	
I/O	-	P169	P193	B7	AG5	D10	
I/O	-	P170	P194	A7	AF6	C9	
I/O	-	-	P195	D9	AL5	B9	
I/O	-	-	-	C9	AJ3	C10	
GND	P131	P171	P196	GND*	GND*	GND*	
I/O	P132	P172	P197	B8	AH2	B10	
I/O	P133	P173	P198	D10	AE5	A10	
I/O	-	-	P199	C10	AM4	C11	
I/O	-	-	P200	B9	AD6	D12	
VCC	-	-	P201	VCC*	VCC*	VCC*	
I/O	-	-	-	A9	AG3	B11	
I/O	-	-	-	D11	AG1	C12	
I/O	-	-	-	C11	AC5	C13	
I/O	-	-	-	B10	AE1	A12	
I/O	-	-	-	B11	AH4	D14	
I/O	-	-	-	A11	AB6	B13	
GND	-	-	-	GND*	GND*	GND*	
VCC	-	-	-	VCC*	VCC*	VCC*	
I/O (A4)	P134	P174	P202	D12	AD2	C14	
I/O (A5)	P135	P175	P203	C12	AB4	A13	
I/O	-	P176	P205	B12	AE3	B14	
I/O	P136	P177	P206	A12	AC1	D15	
I/O (A21)	P137	P178	P207	C13	AD4	C15	
I/O (A20)	P138	P179	P208	B13	AA5	B15	
I/O	-	-	-	-	AB2	A15	
I/O	-	-	-	-	AC3	C16	
I/O (A6)	P139	P180	P209	A13	AA3	B16	
I/O (A7)	P140	P181	P210	B14	Y6	A16	

XC4044XL Pad Name	HQ 160	HQ 208	HQ 240	BG 352	PG 411	BG 432
GND	P141	P182	P211	GND*	GND*	GND*

6/18/97

* Pads labelled GND* or VCC* are internally bonded to Ground or VCC planes within the associated package. They have no direct connection to any specific package pin.

Additional XC4044XL Package Pins

HQ208

N.C. Pins						
P1	P3	P51	P52	P53	P54	P102
P104	P105	P107	P155	P156	P157	P158
P206	P207	P208	-	-	-	-

5/29/97

HQ240

GND Pins						
P204	P219	-	-	-	-	-

5/29/97

Note: These pins may be N.C. for this device revision, however for compatibility with other devices in this package, these pins should be tied to GND.

BG352

VCC Pins						
A10	A17	B2	B25	D7	D13	D19
G23	H4	K1	K26	N23	P4	U1
U26	W23	Y4	AC8	AC14	AC20	AE2
AE25	AF10	AF17	-	-	-	-
GND Pins						
A1	A2	A5	A8	A14	A19	A22
A25	A26	B1	B26	E1	E26	H1
H26	N1	P26	W1	W26	AB1	AB26
AE1	AE26	AF1	AF2	AF5	AF8	AF13
AF19	AF22	AF25	AF26	-	-	-

6/13/97

PG411

VCC Pins						
A3	A11	A21	A31	C39	D6	F36
J1	L39	W1	AA39	AJ1	AL39	AP4
AT34	AU1	AW9	AW19	AW29	AW37	-
GND Pins						
A9	A19	A29	A37	C1	D14	D20
D26	D34	F4	J39	L1	P4	P36
W39	Y4	Y36	AA1	AF4	AF36	AJ39
AL1	AP36	AT6	AT14	AT20	AT26	AU39
AW3	AW11	AW21	AW31	-	-	-
N.C. Pins						
A13	B6	B34	C25	C33	D12	E7
E23	E37	F2	G5	H34	L35	N3
P38	R3	AF2	AF38	AJ5	AL35	AN5
AP8	AR37	AT2	AU5	AU13	AU15	AU25
AU37	AV26	AV34	AW35	-	-	-

6/2/97

BG432

VCC Pins						
A1	A11	A21	A31	C3	C29	D11
D21	L1	L4	L28	L31	AA1	AA4
AA28	AA31	AH11	AH21	AJ3	AJ29	AL1
AL11	AL21	AL31	-	-	-	-
GND Pins						
A2	A3	A7	A9	A14	A18	A23
A25	A29	A30	B1	B2	B30	B31
C1	C31	D16	G1	G31	J1	J31
P1	P31	T4	T28	V1	V31	AC1
AC31	AE1	AE31	AH16	AJ1	AJ31	AK1
AK2	AK30	AK31	AL2	AL3	AL7	AL9
AL14	AL18	AL23	AL25	AL29	AL30	-
N.C. Pins						
A4	A28	B12	B21	C8	D6	D13
D20	D26	E2	F4	F28	F29	M3
M4	M28	M30	W1	W28	Y1	Y31
AE4	AF29	AF30	AG1	AH6	AH19	AJ5
AJ12	AJ20	AJ26	AK11	AK27	-	-

5/29/97

Pin Locations for XC4052XL Devices

(Note: XC4052XL is also available in the HQ304 package. The pinout is identical to the XC4036XL in HQ304.)

XC4052XL Pad Name	HQ 240	PG 411	BG 432	BG 560
VCC	P212	VCC*	VCC*	VCC*
I/O (A8)	P213	W3	D17	A17
I/O (A9)	P214	Y2	A17	B18
I/O	-	V2	C17	C18
I/O	-	W5	B17	E18
GND	-	GND*	GND*	GND*
I/O (A19)	P215	V4	C18	C19
I/O (A18)	P216	T2	D18	D19
I/O	P217	U1	B18	E19
I/O	P218	V6	A19	B20
I/O (A10)	P220	U3	B19	C20
I/O (A11)	P221	R1	C19	D20
VCC	-	VCC*	VCC*	VCC*
GND	-	GND*	GND*	GND*
I/O	-	U5	D19	A21
I/O	-	T4	A20	E20
I/O	-	P2	B20	B21
I/O	-	N1	C20	C21
I/O	-	R3	B21	D21
I/O	-	N3	D20	B22
GND	-	GND*	GND*	GND*
I/O	-	R5	C21	C23
I/O	-	M2	A22	E22
VCC	P222	VCC*	VCC*	VCC*
I/O	P223	L3	B22	B24
I/O	P224	T6	C22	D23
I/O	P225	N5	B23	C24
I/O	P226	M4	A24	A25
GND	P227	GND*	GND*	GND*
I/O	-	K2	D22	E23
I/O	-	K4	C23	B25
I/O	P228	P6	B24	D24
I/O	P229	M6	C24	C25
GND	-	GND*	GND*	GND*
I/O	-	L5	D23	E25
I/O	-	J5	B25	C27
I/O	P230	J3	A26	D26
I/O	P231	H2	C25	B28
I/O (A12)	P232	H4	D24	B29
I/O (A13)	P233	G3	B26	E26

XC4052XL Pad Name	HQ 240	PG 411	BG 432	BG 560
GND	-	GND*	GND*	GND*
VCC	-	VCC*	VCC*	VCC*
I/O	-	K6	A27	C28
I/O	-	G1	D25	D27
I/O	-	E1	C26	B30
I/O	-	E3	B27	C29
I/O	-	F2	A28	E27
I/O	-	G5	D26	A31
GND	-	GND*	GND*	GND*
I/O	P234	J7	C27	D28
I/O	P235	H6	B28	C30
I/O	P236	C3	D27	D29
I/O	P237	D2	B29	E28
I/O (A14)	P238	E5	C28	D30
I/O, GCK8 (A15)	P239	G7	D28	E29
VCC	P240	VCC*	VCC*	VCC*
GND	P1	GND*	GND*	GND*
I/O, GCK1 (A16)	P2	H8	D29	B33
I/O (A17)	P3	F6	C30	F29
I/O	P4	B4	E28	E30
I/O	P5	D4	E29	D31
I/O, TDI	P6	B2	D30	F30
I/O, TCK	P7	G9	D31	C33
GND	-	GND*	GND*	GND*
I/O	-	E7	F28	G29
I/O	-	B6	F29	E31
I/O	-	F8	E30	D32
I/O	-	C5	E31	G30
I/O	-	A7	G28	F31
I/O	-	A5	G29	H29
VCC	-	VCC*	VCC*	VCC*
GND	-	GND*	GND*	GND*
I/O	-	C7	F30	H30
I/O	-	D8	F31	G31
I/O	P8	B8	H28	J29
I/O	P9	C9	H29	F33
I/O	P10	E9	G30	G32
I/O	P11	F12	H30	J30
GND	-	GND*	GND*	GND*
I/O	P12	D10	J28	K30
I/O	P13	B10	J29	H33
I/O	-	F10	H31	L29
I/O	-	F14	J30	K31
GND	P14	GND*	GND*	GND*
I/O	P15	C11	K28	L30

XC4000E and XC4000X Series Field Programmable Gate Arrays

XC4052XL Pad Name	HQ 240	PG 411	BG 432	BG 560
I/O	P16	B12	K29	K32
I/O, TMS	P17	E11	K30	J33
I/O	P18	E15	K31	M29
VCC	P19	VCC*	VCC*	VCC*
I/O	P20	F16	L29	L32
I/O	P21	C13	L30	M31
GND	-	GND*	GND*	GND*
I/O	-	A13	M30	N29
I/O	-	D12	M28	L33
I/O	-	B14	M29	M32
I/O	-	E17	M31	P29
I/O	-	E13	N31	P30
I/O	-	A15	N28	N33
GND	P22	GND*	GND*	GND*
VCC	-	VCC*	VCC*	VCC*
I/O	-	F18	N29	P31
I/O	-	C15	N30	P32
I/O	-	B16	P30	R29
I/O	-	D16	P28	R30
I/O	P23	D18	P29	R31
I/O	P24	A17	R31	R33
GND	-	GND*	GND*	GND*
I/O	P25	E19	R30	T31
I/O	P26	B18	R28	T29
I/O	P27	C17	R29	U32
I/O	P28	C19	T31	U31
GND	P29	GND*	GND*	GND*
VCC	P30	VCC*	VCC*	VCC*
I/O	P31	F20	T30	U29
I/O	P32	B20	T29	U30
I/O	P33	C21	U31	V31
I/O	P34	B22	U30	V29
GND	-	GND*	GND*	GND*
I/O	P35	E21	U28	V30
I/O	P36	D22	U29	W33
I/O	-	A23	V30	W31
I/O	-	B24	V29	W30
I/O	-	C23	V28	W29
I/O	-	F22	W31	Y32
VCC	-	VCC*	VCC*	VCC*
GND	P37	GND*	GND*	GND*
I/O	-	A25	W30	Y31
I/O	-	D24	W29	Y30
I/O	-	E23	W28	AA32
I/O	-	C25	Y31	AA31
I/O	-	B26	Y30	AA30
I/O	-	A27	Y29	AB32
GND	-	GND*	GND*	GND*
I/O	P38	C27	Y28	AA29
I/O	P39	F24	AA30	AB31
VCC	P40	VCC*	VCC*	VCC*
I/O	P41	E25	AA29	AC31
I/O	P42	E27	AB31	AB29
I/O	P43	B28	AB30	AD32
I/O	P44	C29	AB29	AC30
GND	P45	GND*	GND*	GND*
I/O	-	F26	AB28	AD31
I/O	-	D28	AC30	AE33
I/O	P46	B30	AC29	AC29
I/O	P47	E29	AC28	AE32
GND	-	GND*	GND*	GND*
I/O	-	D30	AD31	AG33
I/O	-	D32	AD30	AH33
I/O	P48	F28	AD29	AE29
I/O	P49	F30	AD28	AG31
I/O	P50	C31	AE30	AF30
I/O	P51	E31	AE29	AH32
GND	-	GND*	GND*	GND*
VCC	-	VCC*	VCC*	VCC*
I/O	-	B32	AF31	AJ32

XC4052XL Pad Name	HQ 240	PG 411	BG 432	BG 560
I/O	-	A33	AE28	AF29
I/O	-	C33	AF30	AH31
I/O	-	B34	AF29	AG30
I/O	P52	A35	AG31	AK32
I/O	P53	F32	AF28	AJ31
GND	-	GND*	GND*	GND*
I/O	-	C35	AG30	AG29
I/O	-	B38	AG29	AL33
I/O	P54	E33	AH31	AH30
I/O	P55	G31	AG28	AK31
I/O	P56	H32	AH30	AJ30
I/O, GCK2	P57	B36	AJ30	AH29
O (M1)	P58	A39	AH29	AK30
GND	P59	GND*	GND*	GND*
I (M0)	P60	E35	AH28	AJ29
VCC	P61	VCC*	VCC*	VCC*
I (M2)	P62	G33	AJ28	AN32
I/O, GCK3	P63	D36	AK29	AJ28
I/O (HDC)	P64	C37	AH27	AK29
I/O	P65	F34	AK28	AL30
I/O	P66	J33	AJ27	AK28
I/O	P67	D38	AL28	AM31
I/O (LDC)	P68	G35	AH26	AJ27
GND	-	GND*	GND*	GND*
I/O	-	E37	AK27	AN31
I/O	-	H34	AJ26	AL29
I/O	-	E39	AL27	AK27
I/O	-	K34	AH25	AL28
I/O	-	F38	AK26	AJ26
I/O	-	G37	AL26	AM30
VCC	-	VCC*	VCC*	VCC*
GND	-	GND*	GND*	GND*
I/O	P69	H38	AH24	AM29
I/O	P70	J37	AJ25	AK26
I/O	P71	G39	AK25	AL27
I/O	P72	M34	AJ24	AJ25
I/O	-	K36	AH23	AN29
I/O	-	K38	AK24	AN28
GND	-	GND*	GND*	GND*
I/O	P73	N35	AL24	AL25
I/O	P74	P34	AH22	AJ23
I/O	-	J35	AJ23	AN26
I/O	-	L37	AK23	AL24
GND	P75	GND*	GND*	GND*
I/O	P76	M38	AJ22	AK23
I/O	P77	R35	AK22	AN25
I/O	P78	H36	AL22	AJ22
I/O	P79	T34	AJ21	AL23
VCC	P80	VCC*	VCC*	VCC*
I/O	P81	N37	AH20	AM24
I/O	P82	N39	AK21	AK22
GND	-	GND*	GND*	GND*
I/O	-	P38	AJ20	AK21
I/O	-	L35	AH19	AM22
I/O	-	U35	AK20	AJ20
I/O	-	R39	AJ19	AL21
I/O	-	M36	AL20	AN21
I/O	-	V34	AH18	AK20
GND	P83	GND*	GND*	GND*
VCC	-	VCC*	VCC*	VCC*
I/O	-	R37	AK19	AL20
I/O	-	T38	AJ18	AJ19
I/O	P84	T36	AL19	AM20
I/O	P85	V36	AK18	AK19
I/O	P86	U37	AH17	AL19
I/O	P87	U39	AJ17	AN19
GND	-	GND*	GND*	GND*
I/O	-	W35	AK17	AL18
I/O	-	AC39	AL17	AM18
I/O	P88	V38	AJ16	AK17

XC4052XL Pad Name	HQ 240	PG 411	BG 432	BG 560
I/O (INIT)	P89	W37	AK16	AJ17
VCC	P90	VCC*	VCC*	VCC*
GND	P91	GND*	GND*	GND*
I/O	P92	Y34	AL16	AL17
I/O	P93	AC37	AH15	AM17
I/O	-	Y38	AL15	AN17
I/O	-	AA37	AJ15	AK16
GND	-	GND*	GND*	GND*
I/O	P94	AB38	AK15	AM16
I/O	P95	AD36	AJ14	AL15
I/O	P96	AA35	AH14	AK15
I/O	P97	AE37	AK14	AJ15
I/O	-	AB36	AL13	AN15
I/O	-	AD38	AK13	AM14
VCC	-	VCC*	VCC*	VCC*
GND	P98	GND*	GND*	GND*
I/O	-	AB34	AJ13	AL14
I/O	-	AE39	AH13	AK14
I/O	-	AM36	AL12	AJ14
I/O	-	AC35	AK12	AN13
I/O	-	AL35	AJ12	AM13
I/O	-	AF38	AK11	AL13
GND	-	GND*	GND*	GND*
I/O	P99	AG39	AH12	AK12
I/O	P100	AG37	AJ11	AN11
VCC	P101	VCC*	VCC*	VCC*
I/O	P102	AD34	AL10	AJ12
I/O	P103	AN39	AK10	AL11
I/O	P104	AE35	AJ10	AK11
I/O	P105	AH38	AK9	AM10
GND	P106	GND*	GND*	GND*
I/O	-	AJ37	AL8	AL10
I/O	-	AG35	AH10	AJ11
I/O	P107	AF34	AJ9	AN9
I/O	P108	AH36	AK8	AK10
GND	-	GND*	GND*	GND*
I/O	-	AK38	AJ8	AN7
I/O	-	AP38	AH9	AJ9
I/O	P109	AK36	AK7	AL7
I/O	P110	AM34	AL6	AK8
I/O	P111	AH34	AJ7	AN6
I/O	P112	AJ35	AH8	AM6
GND	-	GND*	GND*	GND*
VCC	-	VCC*	VCC*	VCC*
I/O	-	AL37	AK6	AJ8
I/O	-	AT38	AL5	AL6
I/O	P113	AM38	AH7	AK7
I/O	P114	AN37	AJ6	AM5
I/O	-	AK34	AK5	AM4
I/O	-	AR39	AL4	AJ7
GND	-	GND*	GND*	GND*
I/O	-	AR37	AH6	AL5
I/O	-	AU37	AJ5	AK6
I/O	P115	AN35	AK4	AN3
I/O	P116	AL33	AH5	AK5
I/O	P117	AV38	AK3	AJ6
I/O, GCK4	P118	AT36	AJ4	AL4
GND	P119	GND*	GND*	GND*
DONE	P120	AR35	AH4	AJ5
VCC	P121	VCC*	VCC*	VCC*
PROGRAM	P122	AN33	AH3	AM1
I/O (D7)	P123	AM32	AJ2	AH5
I/O, GCK5	P124	AP34	AG4	AJ4
I/O	P125	AW39	AG3	AK3
I/O	P126	AN31	AH2	AH4
I/O	-	AV36	AH1	AL1
I/O	-	AR33	AF4	AG5
GND	-	GND*	GND*	GND*
I/O	P127	AP32	AF3	AJ3
I/O	P128	AU35	AG2	AK2

XC4052XL Pad Name	HQ 240	PG 411	BG 432	BG 560
I/O	-	AV34	AG1	AG4
I/O	-	AW35	AE4	AH3
I/O	-	AW33	AE3	AF5
I/O	-	AU33	AF2	AJ2
VCC	-	VCC*	VCC*	VCC*
GND	-	GND*	GND*	GND*
I/O (D6)	P129	AV32	AF1	AJ1
I/O	P130	AU31	AD4	AF4
I/O	P131	AR31	AD3	AG3
I/O	P132	AP28	AE2	AE5
I/O	-	AP30	AD2	AH1
I/O	-	AT30	AC4	AF3
GND	-	GND*	GND*	GND*
I/O	P133	AT32	AC3	AE3
I/O	P134	AV30	AD1	AC5
I/O	-	AR29	AC2	AE1
I/O	-	AP26	AB4	AD3
GND	P135	GND*	GND*	GND*
I/O	P136	AU29	AB3	AC4
I/O	P137	AV28	AB2	AD2
I/O	P138	AT28	AB1	AB5
I/O	P139	AR25	AA3	AC3
VCC	P140	VCC*	VCC*	VCC*
I/O (D5)	P141	AP24	AA2	AA5
I/O (CS0)	P142	AU27	Y2	AB3
GND	-	GND*	GND*	GND*
I/O	-	AR27	Y4	AB2
I/O	-	AW27	Y3	AA4
I/O	-	AU25	Y1	AA3
I/O	-	AV26	W1	Y5
I/O	-	AT24	W4	Y3
I/O	-	AR23	W3	Y2
GND	P143	GND*	GND*	GND*
VCC	-	VCC*	VCC*	VCC*
I/O	-	AW25	W2	W5
I/O	-	AW23	V2	W4
I/O	-	AP22	V4	W3
I/O	-	AV24	V3	W1
I/O	P144	AU23	U1	V3
I/O	P145	AT22	U2	V5
GND	-	GND*	GND*	GND*
I/O	P146	AR21	U4	V4
I/O	P147	AV22	U3	V2
I/O (D4)	P148	AP20	T1	U5
I/O	P149	AU21	T2	U4
VCC	P150	VCC*	VCC*	VCC*
GND	P151	GND*	GND*	GND*
I/O (D3)	P152	AU19	T3	U3
I/O (RS)	P153	AV20	R1	T2
I/O	P154	AV18	R2	T4
I/O	P155	AR19	R4	R1
GND	-	GND*	GND*	GND*
I/O	P156	AT18	R3	R3
I/O	P157	AW17	P2	R4
I/O	-	AV16	P3	R5
I/O	-	AP18	P4	P2
I/O	-	AU17	N1	P3
I/O	-	AW15	N2	P4
VCC	-	VCC*	VCC*	VCC*
GND	P158	GND*	GND*	GND*
I/O	-	AR17	N3	N1
I/O	-	AT16	N4	P5
I/O	-	AV14	M1	N2
I/O	-	AW13	M2	N3
I/O	-	AU15	M3	N5
I/O	-	AU13	M4	M3
GND	-	GND*	GND*	GND*
I/O (D2)	P159	AR15	L2	M4
I/O	P160	AP16	L3	L1
VCC	P161	VCC*	VCC*	VCC*

XC4052XL Pad Name	HQ 240	PG 411	BG 432	BG 560
I/O	P162	AV12	K1	K2
I/O	P163	AR13	K2	L4
I/O	P164	AU11	K3	J1
I/O	P165	AT12	K4	K3
GND	P166	GND*	GND*	GND*
I/O	-	AP14	J2	L5
I/O	-	AR11	J3	J2
I/O	P167	AV10	J4	K4
I/O	P168	AT8	H1	J3
GND	-	GND*	GND*	GND*
I/O	P169	AT10	H2	G1
I/O	P170	AP10	H3	F1
I/O	P171	AP12	H4	J5
I/O	P172	AR9	G2	G3
I/O	-	AU9	G3	H4
I/O	-	AV8	F1	F2
GND	-	GND*	GND*	GND*
VCC	-	VCC*	VCC*	VCC*
I/O (D1)	P173	AU7	G4	F3
I/O (RCLK, RDY/BUSY)	P174	AW7	F2	G4
I/O	-	AW5	F3	D2
I/O	-	AV6	E1	E3
I/O	-	AU5	F4	G5
I/O	-	AP8	E2	C1
GND	-	GND*	GND*	GND*
I/O	-	AR7	E3	F4
I/O	-	AV4	D1	D3
I/O	P175	AN9	E4	B3
I/O	P176	AW1	D2	F5
I/O (D0, DIN)	P177	AP6	C2	E4
I/O, GCK6 (DOU7)	P178	AU3	D3	D4
CCLK	P179	AR5	D4	C4
VCC	P180	VCC*	VCC*	VCC*
O, TDO	P181	AN7	C4	E6
GND	P182	GND*	GND*	GND*
I/O (A0, WS)	P183	AT4	B3	D5
I/O, GCK7 (A1)	P184	AV2	D5	A2
I/O	P185	AM8	B4	D6
I/O	P186	AL7	C5	A3
I/O	-	AT2	A4	E7
I/O	-	AN5	D6	C5
GND	-	GND*	GND*	GND*
I/O	-	AR3	B5	B4
I/O	-	AR1	C6	D7
I/O (CS1, A2)	P187	AK6	A5	C6
I/O (A3)	P188	AN3	D7	E8
I/O	-	AM6	B6	B5
I/O	-	AM2	A6	A5
VCC	-	VCC*	VCC*	VCC*
GND	-	GND*	GND*	GND*
I/O	P189	AL3	D8	D8
I/O	P190	AH6	C7	C7
I/O	P191	AP2	B7	E9
I/O	P192	AK4	D9	A6
I/O	-	AN1	B8	B7
I/O	-	AK2	A8	D9
GND	-	GND*	GND*	GND*
I/O	P193	AG5	D10	E11
I/O	P194	AF6	C9	A9
I/O	P195	AL5	B9	C10
I/O	-	AJ3	C10	D11
GND	P196	GND*	GND*	GND*
I/O	P197	AH2	B10	B10
I/O	P198	AE5	A10	E12
I/O	P199	AM4	C11	C11
I/O	P200	AD6	D12	B11
VCC	P201	VCC*	VCC*	VCC*
I/O	-	AG3	B11	D12
I/O	-	AG1	C12	A11
GND	-	GND*	GND*	GND*

XC4052XL Pad Name	HQ 240	PG 411	BG 432	BG 560
I/O	-	AF2	D13	C13
I/O	-	AJ5	B12	E14
I/O	-	AC5	C13	A13
I/O	-	AE1	A12	D14
I/O	-	AH4	D14	C14
I/O	-	AB6	B13	B14
GND	-	GND*	GND*	GND*
VCC	-	VCC*	VCC*	VCC*
I/O (A4)	P202	AD2	C14	E15
I/O (A5)	P203	AB4	A13	D15
I/O	P205	AE3	B14	C15
I/O	P206	AC1	D15	A15
I/O (A21)	P207	AD4	C15	C16
I/O (A20)	P208	AA5	B15	E16
GND	-	GND*	GND*	GND*
I/O	-	AB2	A15	B17
I/O	-	AC3	C16	C17
I/O (A6)	P209	AA3	B16	E17
I/O (A7)	P210	Y6	A16	D17
GND	P211	GND*	GND*	GND*

6/20/97

* Pads labelled GND* or VCC* are internally bonded to Ground or VCC planes within the associated package. They have no direct connection to any specific package pin.

Additional XC4052XL Package Pins

HQ240

GND Pins						
P204	P219	-	-	-	-	-

6/3/97

Note: These pins may be N.C. for this device revision, however for compatability with other devices in this package, these pins should be tied to GND.

PG411

VCC Pins						
A3	A11	A21	A31	C39	D6	F36
J1	L39	W1	AA39	AJ1	AL39	AP4
AT34	AU1	AW9	AW19	AW29	AW37	-
GND Pins						
A9	A19	A29	A37	C1	D14	D20
D26	D34	F4	J39	LI	P4	P36
W39	Y4	Y36	AA1	AF4	AF36	AJ39
AL1	AP36	AT6	AT14	AT20	AT26	AU39
AW3	AW11	AW21	AW31	-	-	-

6/3/97

BG432

VCC Pins						
A1	A11	A21	A31	C3	C29	D11
D21	L1	L4	L28	L31	AA1	AA4
AA28	AA31	AH11	AH21	AJ3	AJ29	AL1
AL11	AL21	AL31	-	-	-	-
GND Pins						
A2	A3	A7	A9	A14	A18	A23
A25	A29	A30	B1	B2	B30	B31
C1	C31	D16	G1	G31	J1	J31
P1	P31	T4	T28	V1	V31	AC1
AC31	AE1	AE31	AH16	AJ1	AJ31	AK1
AK2	AK30	AK31	AL2	AL3	AL7	AL9
AL14	AL18	AL23	AL25	AL29	AL30	-
N.C. Pins						
C8	-	-	-	-	-	-

6/3/97

PG560

VCC Pins						
A4	A10	A16	A22	A26	A30	B2
B13	B19	B32	C3	C31	C32	D1
D33	E5	H1	K33	M1	N32	R2
T33	V1	W32	AA2	AB33	AD1	AF33
AK1	AK4	AK33	AL2	AL3	AL31	AM2
AM15	AM21	AM32	AN4	AN8	AN12	AN18
AN24	AN30	-	-	-	-	-
GND Pins						
A7	A12	A14	A18	A20	A24	A29
A32	B1	B6	B9	B15	B23	B27
B31	C2	E1	F32	G2	G33	J32
K1	L2	M33	P1	P33	R32	T1
V33	W2	Y1	Y33	AB1	AC32	AD33
AE2	AG1	AG32	AH2	AJ33	AL32	AM3
AM7	AM11	AM19	AM25	AM28	AM33	AN2
AN5	AN10	AN14	AN16	AN20	AN22	AN27
N.C. Pins						
A1	A8	A19	A23	A27	A28	A33
B8	B12	B16	B26	C8	C9	C12
C22	C26	D10	D13	D16	D18	D22
D25	E2	E10	E13	E21	E24	E32
E33	H2	H3	H5	H31	H32	J4
J31	K5	K29	L3	L31	M2	M5
M30	N4	N30	N31	T3	T5	T30
T32	U1	U2	U33	V32	Y4	Y29
AA1	AA33	AB4	AB30	AC1	AC2	AC33
AD4	AD5	AD29	AD30	AE4	AE30	AE31
AF1	AF2	AF31	AF32	AG2	AJ10	AJ13
AJ16	AJ18	AJ21	AJ24	AK9	AK13	AK18
AK24	AK25	AL8	AL9	AL12	AL16	AL22
AL26	AM8	AM9	AM12	AM23	AM26	AM27
AN1	AN23	AN33	-	-	-	-

6/20/97

Pin Locations for XC4062XL Devices

(Note: XC4062XL is also available in the HQ304 package. The pinout is identical to the XC4036XL in HQ304.)

XC4062XL Pad Name	HQ240	BG432	PG475	BG560
VCC	P212	VCC*	VCC*	VCC*
I/O (A8)	P213	D17	Y2	A17
I/O (A9)	P214	A17	Y4	B18
I/O	-	C17	W5	C18
I/O	-	B17	Y6	E18
I/O	-	-	U3	D18
I/O	-	-	W3	A19
GND	-	GND*	GND*	GND*
I/O (A19)	P215	C18	W1	C19
I/O (A18)	P216	D18	U5	D19
I/O	P217	B18	W7	E19
I/O	P218	A19	U7	B20
I/O (A10)	P220	B19	V2	C20
I/O (A11)	P221	C19	V4	D20
VCC	-	VCC*	VCC*	VCC*
GND	-	GND*	GND*	GND*
I/O	-	D19	V6	A21
I/O	-	A20	R1	E20
I/O	-	B20	T6	B21
I/O	-	C20	R3	C21
I/O	-	B21	R5	D21
I/O	-	D20	T4	B22
GND	-	GND*	GND*	GND*
I/O	-	C21	P2	C23
I/O	-	A22	N1	E22
VCC	P222	VCC*	VCC*	VCC*
I/O	P223	B22	N3	B24

XC4062XL Pad Name	HQ240	BG432	PG475	BG560
I/O	P224	C22	P4	D23
I/O	P225	B23	R7	C24
I/O	P226	A24	M2	A25
GND	P227	GND*	GND*	GND*
I/O	-	D22	M4	E23
I/O	-	C23	L3	B25
I/O	P228	B24	N5	D24
I/O	P229	C24	K2	C25
I/O	-	-	L5	B26
I/O	-	-	J1	E24
GND	-	GND*	GND*	GND*
I/O	-	D23	M6	E25
I/O	-	B25	K4	C27
I/O	P230	A26	J3	D26
I/O	P231	C25	J5	B28
I/O (A12)	P232	D24	H2	B29
I/O (A13)	P233	B26	G1	E26
GND	-	GND*	GND*	GND*
VCC	-	VCC*	VCC*	VCC*
I/O	-	A27	L7	C28
I/O	-	D25	K6	D27
I/O	-	C26	E1	B30
I/O	-	B27	H4	C29
I/O	-	A28	G5	E27
I/O	-	D26	F2	A31
GND	-	GND*	GND*	GND*
I/O	P234	C27	H6	D28
I/O	P235	B28	C3	C30
I/O	P236	D27	F4	D29
I/O	P237	B29	C5	E28

XC4000E and XC4000X Series Field Programmable Gate Arrays

XC4062XL Pad Name	HQ240	BG432	PG475	BG560
I/O (A14)	P238	C28	E3	D30
I/O GCK8 (A15)	P239	D28	E5	E29
VCC	P240	VCC*	VCC*	VCC*
GND	P1	GND*	GND*	GND*
I/O, GCK1 (A16)	P2	D29	G7	B33
I/O (A17)	P3	C30	D4	F29
I/O	P4	E28	A5	E30
I/O	P5	E29	B4	D31
I/O, TDI	P6	D30	D6	F30
I/O, TCK	P7	D31	F8	C33
GND	-	GND*	GND*	GND*
I/O	-	F28	B6	G29
I/O	-	F29	E7	E31
I/O	-	E30	D8	D32
I/O	-	E31	G9	G30
I/O	-	G28	E9	F31
I/O	-	G29	A7	H29
VCC	-	VCC*	VCC*	VCC*
GND	-	GND*	GND*	GND*
I/O	-	F30	B8	H30
I/O	-	F31	C9	G31
I/O	P8	H28	G11	J29
I/O	P9	H29	D10	F33
I/O	P10	G30	E11	G32
I/O	P11	H30	A9	J30
GND	-	GND*	GND*	GND*
I/O	-	-	B10	H32
I/O	-	-	C11	J31
I/O	P12	J28	F12	K30
I/O	P13	J29	D12	H33
I/O	-	H31	A11	L29
I/O	-	J30	G15	K31
GND	P14	GND*	GND*	GND*
I/O	P15	K28	B12	L30
I/O	P16	K29	E13	K32
I/O, TMS	P17	K30	C13	J33
I/O	P18	K31	A13	M29
VCC	P19	VCC*	VCC*	VCC*
I/O	P20	L29	B14	L32
I/O	P21	L30	C15	M31
GND	-	GND*	GND*	GND*
I/O	-	M30	G17	N29
I/O	-	M28	F14	L33
I/O	-	M29	D16	M32
I/O	-	M31	D14	P29
I/O	-	N31	A15	P30
I/O	-	N28	C17	N33
GND	P22	GND*	GND*	GND*
VCC	-	VCC*	VCC*	VCC*
I/O	-	N29	D18	P31
I/O	-	N30	B18	P32
I/O	-	P30	F16	R29
I/O	-	P28	G19	R30
I/O	P23	P29	E17	R31
I/O	P24	R31	E19	R33
GND	-	GND*	GND*	GND*
I/O	P25	R30	A19	T31
I/O	P26	R28	F18	T29
I/O	-	-	C19	T30
I/O	-	-	D20	T32
I/O	P27	R29	F20	U32
I/O	P28	T31	B20	U31
GND	P29	GND*	GND*	GND*
VCC	P30	VCC*	VCC*	VCC*
I/O	P31	T30	C21	U29
I/O	P32	T29	A21	U30
I/O	-	-	D22	U33
I/O	-	-	B22	V32
I/O	P33	U31	E23	V31
I/O	P34	U30	F22	V29

XC4062XL Pad Name	HQ240	BG432	PG475	BG560
GND	-	GND*	GND*	GND*
I/O	P35	U28	C23	V30
I/O	P36	U29	F24	W33
I/O	-	V30	A23	W31
I/O	-	V29	E25	W30
I/O	-	V28	G23	W29
I/O	-	W31	B24	Y32
VCC	-	VCC*	VCC*	VCC*
GND	P37	GND*	GND*	GND*
I/O	-	W30	D24	Y31
I/O	-	W29	C25	Y30
I/O	-	W28	D28	AA32
I/O	-	Y31	A27	AA31
I/O	-	Y30	E29	AA30
I/O	-	Y29	C27	AB32
GND	-	GND*	GND*	GND*
I/O	P38	Y28	G25	AA29
I/O	P39	AA30	D26	AB31
VCC	P40	VCC*	VCC*	VCC*
I/O	P41	AA29	F26	AC31
I/O	P42	AB31	B28	AB29
I/O	P43	AB30	D30	AD32
I/O	P44	AB29	A29	AC30
GND	P45	GND*	GND*	GND*
I/O	-	AB28	C29	AD31
I/O	-	AC30	G27	AE33
I/O	P46	AC29	F30	AC29
I/O	P47	AC28	B30	AE32
I/O	-	-	E31	AD30
I/O	-	-	C31	AE31
GND	-	GND*	GND*	GND*
I/O	-	AD31	F28	AG33
I/O	-	AD30	D32	AH33
I/O	P48	AD29	B32	AE29
I/O	P49	AD28	G31	AG31
I/O	P50	AE30	A33	AF30
I/O	P51	AE29	C33	AH32
GND	-	GND*	GND*	GND*
VCC	-	VCC*	VCC*	VCC*
I/O	-	AF31	B34	AJ32
I/O	-	AE28	A35	AF29
I/O	-	AF30	E33	AH31
I/O	-	AF29	D34	AG30
I/O	P52	AG31	D36	AK32
I/O	P53	AF28	B36	AJ31
GND	-	GND*	GND*	GND*
I/O	-	AG30	F34	AG29
I/O	-	AG29	D38	AL33
I/O	P54	AH31	C37	AH30
I/O	P55	AG28	G37	AK31
I/O	P56	AH30	B38	AJ30
I/O, GCK2	P57	AJ30	F38	AH29
O (M1)	P58	AH29	A39	AK30
GND	P59	GND*	GND*	GND*
I (M0)	P60	AH28	E35	AJ29
VCC	P61	VCC*	VCC*	VCC*
I (M2)	P62	AJ28	G33	AN32
I/O, GCK3	P63	AK29	J37	AJ28
I/O (HDC)	P64	AH27	G35	AK29
I/O	P65	AK28	K36	AL30
I/O	P66	AJ27	C39	AK28
I/O	P67	AL28	K38	AM31
I/O (LDC)	P68	AH26	C41	AJ27
GND	-	GND*	GND*	GND*
I/O	-	AK27	D40	AN31
I/O	-	AJ26	L37	AL29
I/O	-	AL27	H36	AK27
I/O	-	AH25	M36	AL28
I/O	-	AK26	J35	AJ26
I/O	-	AL26	E41	AM30

XC4062XL Pad Name	HQ240	BG432	PG475	BG560
VCC	-	VCC*	VCC*	VCC*
GND	-	GND*	GND*	GND*
I/O	P69	AH24	F40	AM29
I/O	P70	AJ25	H38	AK26
I/O	P71	AK25	N37	AL27
I/O	P72	AJ24	L35	AJ25
I/O	-	AH23	R35	AN29
I/O	-	AK24	G41	AN28
GND	-	GND*	GND*	GND*
I/O	-	-	H40	AM26
I/O	-	-	P38	AK24
I/O	P73	AL24	J39	AL25
I/O	P74	AH22	R37	AJ23
I/O	-	AJ23	J41	AN26
I/O	-	AK23	K40	AL24
GND	P75	GND*	GND*	GND*
I/O	P76	AJ22	L39	AK23
I/O	P77	AK22	M38	AN25
I/O	P78	AL22	T36	AJ22
I/O	P79	AJ21	M40	AL23
VCC	P80	VCC*	VCC*	VCC*
I/O	P81	AH20	N39	AM24
I/O	P82	AK21	N41	AK22
GND	-	GND*	GND*	GND*
I/O	-	AJ20	P40	AK21
I/O	-	AH19	T38	AM22
I/O	-	AK20	U35	AJ20
I/O	-	AJ19	U37	AL21
I/O	-	AL20	R39	AN21
I/O	-	AH18	R41	AK20
GND	P83	GND*	GND*	GND*
VCC	-	VCC*	VCC*	VCC*
I/O	-	AK19	V36	AL20
I/O	-	AJ18	U39	AJ19
I/O	P84	AL19	V38	AM20
I/O	P85	AK18	V40	AK19
I/O	P86	AH17	W37	AL19
I/O	P87	AJ17	W35	AN19
GND	-	GND*	GND*	GND*
I/O	-	-	W41	AJ18
I/O	-	-	Y36	AK18
I/O	-	AK17	W39	AL18
I/O	-	AL17	AB36	AM18
I/O	P88	AJ16	Y40	AK17
I/O (INIT)	P89	AK16	Y38	AJ17
VCC	P90	VCC*	VCC*	VCC*
GND	P91	GND*	GND*	GND*
I/O	P92	AL16	AA39	AL17
I/O	P93	AH15	AB38	AM17
I/O	-	AL15	AB40	AN17
I/O	-	AJ15	AC37	AK16
I/O	-	-	AC39	AJ16
I/O	-	-	AC41	AL16
GND	-	GND*	GND*	GND*
I/O	P94	AK15	AD36	AM16
I/O	P95	AJ14	AC35	AL15
I/O	P96	AH14	AE37	AK15
I/O	P97	AK14	AD40	AJ15
I/O	-	AL13	AD38	AN15
I/O	-	AK13	AE39	AM14
VCC	-	VCC*	VCC*	VCC*
GND	P98	GND*	GND*	GND*
I/O	-	AJ13	AG41	AL14
I/O	-	AH13	AG39	AK14
I/O	-	AL12	AG37	AJ14
I/O	-	AK12	AE35	AN13
I/O	-	AJ12	AH38	AM13
I/O	-	AK11	AF38	AL13
GND	-	GND*	GND*	GND*
I/O	P99	AH12	AF36	AK12

XC4062XL Pad Name	HQ240	BG432	PG475	BG560
I/O	P100	AJ11	AH40	AN11
VCC	P101	VCC*	VCC*	VCC*
I/O	P102	AL10	AJ41	AJ12
I/O	P103	AK10	AJ39	AL11
I/O	P104	AJ10	AJ37	AK11
I/O	P105	AK9	AG35	AM10
GND	P106	GND*	GND*	GND*
I/O	-	AL8	AK40	AL10
I/O	-	AH10	AK38	AJ11
I/O	P107	AJ9	AL37	AN9
I/O	P108	AK8	AL39	AK10
I/O	-	-	AM38	AM9
I/O	-	-	AM40	AL9
GND	-	GND*	GND*	GND*
I/O	-	AJ8	AN41	AN7
I/O	-	AH9	AM36	AJ9
I/O	P109	AK7	AK36	AL7
I/O	P110	AL6	AU41	AK8
I/O	P111	AJ7	AN39	AN6
I/O	P112	AH8	AP40	AM6
GND	-	GND*	GND*	GND*
VCC	-	VCC*	VCC*	VCC*
I/O	-	AK6	AR41	AJ8
I/O	-	AL5	AL35	AL6
I/O	P113	AH7	AV40	AK7
I/O	P114	AJ6	AN37	AM5
I/O	-	AK5	AT38	AM4
I/O	-	AL4	AP38	AJ7
GND	-	GND*	GND*	GND*
I/O	-	AH6	AT40	AL5
I/O	-	AJ5	AW39	AK6
I/O	P115	AK4	AP36	AN3
I/O	P116	AH5	AU37	AK5
I/O	P117	AK3	AR37	AJ6
I/O, GCK4	P118	AJ4	AU39	AL4
GND	P119	GND*	GND*	GND*
DONE	P120	AH4	AR35	AJ5
VCC	P121	VCC*	VCC*	VCC*
PROGRAM	P122	AH3	AN35	AM1
I/O (D7)	P123	AJ2	AU35	AH5
I/O, GCK5	P124	AG4	AV38	AJ4
I/O	P125	AG3	AT34	AK3
I/O	P126	AH2	BA39	AH4
I/O	-	AH1	AU33	AL1
I/O	-	AF4	AY38	AG5
GND	-	GND*	GND*	GND*
I/O	P127	AF3	AV36	AJ3
I/O	P128	AG2	AR31	AK2
I/O	-	AG1	AR33	AG4
I/O	-	AE4	AV32	AH3
I/O	-	AE3	BA37	AF5
I/O	-	AF2	AY36	AJ2
VCC	-	VCC*	VCC*	VCC*
GND	-	GND*	GND*	GND*
I/O (D6)	P129	AF1	AV34	AJ1
I/O	P130	AD4	BA35	AF4
I/O	P131	AD3	AU31	AG3
I/O	P132	AE2	AY34	AE5
I/O	-	AD2	AT30	AH1
I/O	-	AC4	AW33	AF3
GND	-	GND*	GND*	GND*
I/O	-	-	BA33	AF1
I/O	-	-	AV30	AD4
I/O	P133	AC3	AY32	AE3
I/O	P134	AD1	AU29	AC5
I/O	-	AC2	AW31	AE1
I/O	-	AB4	BA31	AD3
GND	P135	GND*	GND*	GND*
I/O	P136	AB3	AR27	AC4
I/O	P137	AB2	AT28	AD2

XC4000E and XC4000X Series Field Programmable Gate Arrays

XC4062XL Pad Name	HQ240	BG432	PG475	BG560
I/O	P138	AB1	AY30	AB5
I/O	P139	AA3	AW29	AC3
VCC	P140	VCC*	VCC*	VCC*
I/O (D5)	P141	AA2	BA29	AA5
I/O (CS0)	P142	Y2	AY28	AB3
GND	P143	GND*	GND*	GND*
I/O	-	Y4	AR25	AB2
I/O	-	Y3	AV28	AA4
I/O	-	Y1	AW27	AA3
I/O	-	W1	AT26	Y5
I/O	-	W4	AV26	Y3
I/O	-	W3	BA27	Y2
GND	-	GND*	GND*	GND*
VCC	-	VCC*	VCC*	VCC*
I/O	-	W2	AW25	W5
I/O	-	V2	AV24	W4
I/O	-	V4	AU25	W3
I/O	-	V3	AR23	W1
I/O	P144	U1	AT24	V3
I/O	P145	U2	AY24	V5
GND	-	GND*	GND*	GND*
I/O	P146	U4	BA23	V4
I/O	P147	U3	AU23	V2
I/O	-	-	AW23	U2
I/O	-	-	AV20	U1
I/O (D4)	P148	T1	AY22	U5
I/O	P149	T2	AV22	U4
VCC	P150	VCC*	VCC*	VCC*
GND	P151	GND*	GND*	GND*
I/O (D3)	P152	T3	AW21	U3
I/O (RS)	P153	R1	BA21	T2
I/O	-	-	AU19	T3
I/O	-	-	AY20	T5
I/O	P154	R2	AU17	T4
I/O	P155	R4	AW19	R1
GND	-	GND*	GND*	GND*
I/O	P156	R3	BA19	R3
I/O	P157	P2	AT16	R4
I/O	-	P3	AR19	R5
I/O	-	P4	AV14	P2
I/O	-	N1	AY18	P3
I/O	-	N2	AV18	P4
VCC	-	VCC*	VCC*	VCC*
GND	P158	GND*	GND*	GND*
I/O	-	N3	AT18	N1
I/O	-	N4	AW17	P5
I/O	-	M1	AR15	N2
I/O	-	M2	BA15	N3
I/O	-	M3	AT14	N5
I/O	-	M4	AR17	M3
GND	-	GND*	GND*	GND*
I/O (D2)	P159	L2	AW15	M4
I/O	P160	L3	AV16	L1
VCC	P161	VCC*	VCC*	VCC*
I/O	P162	K1	AY14	K2
I/O	P163	K2	BA13	L4
I/O	P164	K3	AU13	J1
I/O	P165	K4	AW13	K3
GND	P166	GND*	GND*	GND*
I/O	-	J2	AY12	L5
I/O	-	J3	BA11	J2
I/O	P167	J4	AV12	K4
I/O	P168	H1	AT12	J3
I/O	-	-	AW11	H2
I/O	-	-	AY10	K5
GND	-	GND*	GND*	GND*
I/O	P169	H2	BA9	G1
I/O	P170	H3	AU11	F1
I/O	P171	H4	AW9	J5
I/O	P172	G2	AV10	G3

XC4062XL Pad Name	HQ240	BG432	PG475	BG560
I/O	-	G3	AY8	H4
I/O	-	F1	BA7	F2
GND	-	GND*	GND*	GND*
VCC	-	VCC*	VCC*	VCC*
I/O (D1)	P173	G4	AV8	F3
I/O (RCLK, RDY/BUSY)	P174	F2	AY6	G4
I/O	-	F3	AR11	D2
I/O	-	E1	AT8	E3
I/O	-	F4	AU9	G5
I/O	-	E2	AW5	C1
GND	-	GND*	GND*	GND*
I/O	-	E3	AY4	F4
I/O	-	D1	BA5	D3
I/O	P175	E4	AV4	B3
I/O	P176	D2	AR9	F5
I/O (D0, DIN)	P177	C2	AU5	E4
I/O, GCK6 (DOUT)	P178	D3	AV6	D4
CCLK	P179	D4	AR5	C4
VCC	P180	VCC*	VCC*	VCC*
O, TDO	P181	C4	AN7	E6
GND	P182	GND*	GND*	GND*
I/O (A0, WS)	P183	B3	AR7	D5
I/O, GCK7 (A1)	P184	D5	AW3	A2
I/O	P185	B4	AU3	D6
I/O	P186	C5	AW1	A3
I/O	-	A4	AP6	E7
I/O	-	D6	AV2	C5
GND	-	GND*	GND*	GND*
I/O	-	B5	AT4	B4
I/O	-	C6	AN5	D7
I/O (CS1, A2)	P187	A5	AU1	C6
I/O (A3)	P188	D7	AM6	E8
I/O	-	B6	AT2	B5
I/O	-	A6	AL7	A5
VCC	-	VCC*	VCC*	VCC*
GND	-	GND*	GND*	GND*
I/O	P189	D8	AR1	D8
I/O	P190	C7	AP2	C7
I/O	P191	B7	AM4	E9
I/O	P192	D9	AN3	A6
I/O	-	B8	AL5	B7
I/O	-	A8	AK6	D9
GND	-	GND*	GND*	GND*
I/O	-	-	AN1	D10
I/O	-	-	AJ5	C9
I/O	P193	D10	AM2	E11
I/O	P194	C9	AH4	A9
I/O	P195	B9	AL3	C10
I/O	-	C10	AK4	D11
GND	P196	GND*	GND*	GND*
I/O	P197	B10	AG7	B10
I/O	P198	A10	AG5	E12
I/O	P199	C11	AK2	C11
I/O	P200	D12	AJ3	B11
VCC	P201	VCC*	VCC*	VCC*
I/O	-	B11	AJ1	D12
I/O	-	C12	AF6	A11
GND	-	GND*	GND*	GND*
I/O	-	D13	AH2	C13
I/O	-	B12	AF4	E14
I/O	-	C13	AE7	A13
I/O	-	A12	AE5	D14
I/O	-	D14	AG3	C14
I/O	-	B13	AG1	B14
GND	-	GND*	GND*	GND*
VCC	-	VCC*	VCC*	VCC*
I/O (A4)	P202	C14	AD6	E15
I/O (A5)	P203	A13	AD4	D15
I/O	P205	B14	AE3	C15
I/O	P206	D15	AC5	A15

XC4062XL Pad Name	HQ240	BG432	PG475	BG560
I/O (A21)	P207	C15	AD2	C16
I/O (A20)	P208	B15	AC7	E16
GND	-	GND*	GND*	GND*
I/O	-	-	AC1	D16
I/O	-	-	AC3	B16
I/O	-	A15	AB6	B17
I/O	-	C16	AB2	C17
I/O (A6)	P209	B16	AB4	E17
I/O (A7)	P210	A16	AA3	D17
GND	P211	GND*	GND*	GND*

6/16/97

* Pads labelled GND* or VCC* are internally bonded to Ground or VCC planes within the package. They have no direct connection to any specific package pin.

Additional XC4062XL Package Pins

HQ240

GND Pins					
P204	P219	-	-	-	-

5/5/97

Note: These pins may be N.C. for this device revision, however for compatibility with other devices in this package, these pins should be tied to GND.

BG432

VCC Pins						
A1	A11	A21	A31	C3	C29	D11
D21	L1	L4	L28	L31	AA1	AA4
AA28	AA31	AH11	AH21	AJ3	AJ29	AL1
AL11	AL21	AL31	-	-	-	-
GND Pins						
A2	A3	A7	A9	A14	A18	A23
A25	A29	A30	B1	B2	B30	B31
C1	C31	D16	G1	G31	J1	J31
P1	P31	T4	T28	V1	V31	AC1
AC31	AE1	AE31	AH16	AJ1	AJ31	AK1
AK2	AK30	AK31	AL2	AL3	AL7	AL9
AL14	AL18	AL23	AL25	AL29	AL30	-
N.C. Pins						
C8	-	-	-	-	-	-

5/5/97

PG475

VCC Pins					
A37	B2	B16	B26	B40	D2
E21	F6	F36	G13	G29	N7
N35	T2	T40	AA1	AA5	AA37
AA41	AF2	AF40	AJ7	AJ35	AR13
AR29	AT6	AT22	AT36	AU21	AW37
AW41	AY2	AY16	AY26	AY40	BA3
GND Pins					
A3	C1	C7	G3	L1	P6
U1	A17	A25	A41	AA7	AE1
AH6	AL1	AR3	AW7	BA1	C35
E15	E27	F10	F32	G21	G39
L41	P36	U41	AA35	AE41	AH36
AL41	AR21	AR39	AT10	AT20	AT32
AU15	AU27	AW35	BA17	BA25	BA41
E37	E39	A31	J7	AP4	AU7

5/5/97

BG560

VCC Pins						
A4	A10	A16	A22	A26	A30	B2
B13	B19	B32	C3	C31	C32	D1
D33	E5	H1	K33	M1	N32	R2
T33	V1	W32	AA2	AB33	AD1	AF33
AK1	AK4	AK33	AL2	AL3	AL31	AM2
AM15	AM21	AM32	AN4	AN8	AN12	AN18
AN24	AN30	-	-	-	-	-
GND Pins						
A7	A12	A14	A18	A20	A24	A29
A32	B1	B6	B9	B15	B23	B27
B31	C2	E1	F32	G2	G33	J32
K1	L2	M33	P1	P33	R32	T1
V33	W2	Y1	Y33	AB1	AC32	AD33
AE2	AG1	AG32	AH2	AJ33	AL32	AM3
AM11	AM19	AM25	AM28	AM33	AM7	AN2
AN5	AN10	AN14	AN16	AN20	AN22	AN27
N.C. Pins						
A1	A8	A23	A27	A28	A33	B8
B12	C8	C12	C22	C26	D13	D22
D25	E2	E10	E13	E21	E32	E33
H3	H5	H31	J4	K29	L3	L31
M2	M5	M30	N4	N30	N31	Y4
Y29	AA1	AA33	AB4	AB30	AC1	AC2
AC33	AD5	AD29	AE4	AE30	AF2	AF31
AF32	AG2	AJ10	AJ13	AJ21	AJ24	AK9
AK13	AK25	AL8	AL12	AL22	AL26	AM8
AM12	AM23	AM27	AN1	AN23	AN33	-

5/5/97

Pin Locations for XC4085XL Devices

XC4085XL Pad Name	BG560	PG559
VCC	VCC*	VCC*
I/O (A8)	A17	AB6
I/O (A9)	B18	AB4
I/O	C18	AA7
I/O	E18	AC1
I/O	D18	AA5
I/O	A19	AA3
GND	GND*	GND*
I/O (A19)	C19	Y8
I/O (A18)	D19	AB2
I/O	E19	Y6
I/O	B20	AA1
I/O (A10)	C20	Y4
I/O (A11)	D20	W7
VCC	VCC*	VCC*

XC4085XL Pad Name	BG560	PG559
GND	GND*	GND*
I/O	A21	W5
I/O	E20	V6
I/O	B21	V4
I/O	C21	Y2
I/O	D21	U3
I/O	B22	U7
I/O	E21	V2
I/O	C22	U5
GND	GND*	GND*
I/O	D22	T4
I/O	A23	U1
I/O	C23	R3
I/O	E22	R5
VCC	VCC*	VCC*

XC4000E and XC4000X Series Field Programmable Gate Arrays

XC4085XL Pad Name	BG560	PG559
I/O	B24	T8
I/O	D23	T2
I/O	C24	P4
I/O	A25	R7
GND	GND*	GND*
I/O	E23	N3
I/O	B25	R1
I/O	D24	N5
I/O	C25	P2
I/O	B26	M4
I/O	E24	L1
I/O	C26	L3
I/O	D25	P8
GND	GND*	GND*
VCC	VCC*	VCC*
I/O	A27	N7
I/O	A28	K2
I/O	E25	M6
I/O	C27	J1
I/O	D26	L5
I/O	B28	H2
I/O (A12)	B29	K4
I/O (A13)	E26	J3
GND	GND*	GND*
VCC	VCC*	VCC*
I/O	C28	L7
I/O	D27	J5
I/O	B30	G1
I/O	C29	H4
I/O	E27	F2
I/O	A31	G5
GND	GND*	GND*
I/O	D28	H6
I/O	C30	K8
I/O	D29	D2
I/O	E28	J7
I/O (A14)	D30	F4
I/O, GCK8 (A15)	E29	E3
VCC	VCC*	VCC*
GND	GND*	GND*
I/O, GCK1 (A16)	B33	C1
I/O (A17)	F29	C3
I/O	E30	F6
I/O	D31	A3
I/O (TDI)	F30	H8
I/O (TCK)	C33	D4
GND	GND*	GND*
I/O	G29	D6
I/O	E31	C5
I/O	D32	E7
I/O	G30	B4
I/O	F31	H10
I/O	H29	G9
VCC	VCC*	VCC*
GND	GND*	GND*
I/O	E32	F8
I/O	E33	D8
I/O	H30	B6
I/O	G31	E9
I/O	J29	A7
I/O	F33	G11
I/O	G32	H14
I/O	J30	F12
VCC	VCC*	VCC*
GND	GND*	GND*
I/O	H31	G13
I/O	K29	E11
I/O	H32	B8
I/O	J31	D10
I/O	K30	A9

XC4085XL Pad Name	BG560	PG559
I/O	H33	G15
I/O	L29	B10
I/O	K31	H16
GND	GND*	GND*
I/O	L30	C9
I/O	K32	E13
I/O (TMS)	J33	A11
I/O	M29	D12
VCC	VCC*	VCC*
I/O	L31	C11
I/O	M30	B14
I/O	L32	G17
I/O	M31	E15
GND	GND*	GND*
I/O	N29	D14
I/O	L33	A15
I/O	N30	C13
I/O	N31	B16
I/O	M32	E17
I/O	P29	F18
I/O	P30	A17
I/O	N33	G19
GND	GND*	GND*
VCC	VCC*	VCC*
I/O	P31	D16
I/O	P32	C15
I/O	R29	B18
I/O	R30	H20
I/O	R31	B20
I/O	R33	E19
GND	GND*	GND*
I/O	T31	D18
I/O	T29	F20
I/O	T30	G21
I/O	T32	C17
I/O	U32	D20
I/O	U31	E21
GND	GND*	GND*
VCC	VCC*	VCC*
I/O	U29	C21
I/O	U30	F22
I/O	U33	A21
I/O	V32	D22
I/O	V31	B22
I/O	V29	G23
GND	GND*	GND*
I/O	V30	E23
I/O	W33	C23
I/O	W31	A23
I/O	W30	D24
I/O	W29	B24
I/O	Y32	H24
VCC	VCC*	VCC*
GND	GND*	GND*
I/O	Y31	F24
I/O	Y30	E25
I/O	AA33	B26
I/O	Y29	D26
I/O	AA32	A27
I/O	AA31	G25
I/O	AA30	B28
I/O	AB32	C27
GND	GND*	GND*
I/O	AA29	F26
I/O	AB31	E27
I/O	AB30	A29
I/O	AC33	D28
VCC	VCC*	VCC*
I/O	AC31	G27
I/O	AB29	B30

XC4085XL Pad Name	BG560	PG559
I/O	AD32	C29
I/O	AC30	E29
GND	GND*	GND*
I/O	AD31	D30
I/O	AE33	A33
I/O	AC29	C31
I/O	AE32	B34
I/O	AD30	H28
I/O	AE31	A35
I/O	AF32	G29
I/O	AD29	E31
GND	GND*	GND*
VCC	VCC*	VCC*
I/O	AF31	D32
I/O	AE30	C35
I/O	AG33	C33
I/O	AH33	B36
I/O	AE29	H30
I/O	AG31	A37
I/O	AF30	G31
I/O	AH32	F32
GND	GND*	GND*
VCC	VCC*	VCC*
I/O	AJ32	E33
I/O	AF29	D34
I/O	AH31	B38
I/O	AG30	G33
I/O	AK32	A41
I/O	AJ31	E35
GND	GND*	GND*
I/O	AG29	D36
I/O	AL33	F36
I/O	AH30	G35
I/O	AK31	H34
I/O	AJ30	B40
I/O, GCK2	AH29	E37
O (M1)	AK30	D38
GND	GND*	GND*
I (M0)	AJ29	C39
VCC	VCC*	VCC*
I (M2)	AN32	H36
I/O, GCK3	AJ28	F38
I/O (HDC)	AK29	C41
I/O	AL30	D40
I/O	AK28	B42
I/O	AM31	J37
I/O (LDC)	AJ27	K36
GND	GND*	GND*
I/O	AN31	H38
I/O	AL29	D42
I/O	AK27	G39
I/O	AL28	C43
I/O	AJ26	F40
I/O	AM30	E41
VCC	VCC*	VCC*
GND	GND*	GND*
I/O	AM29	L37
I/O	AK26	J39
I/O	AL27	F42
I/O	AJ25	H40
I/O	AN29	G43
I/O	AN28	J41
I/O	AK25	H42
I/O	AL26	N37
VCC	VCC*	VCC*
GND	GND*	GND*
I/O	AJ24	P36
I/O	AM27	M38
I/O	AM26	J43
I/O	AK24	L39

XC4085XL Pad Name	BG560	PG559
I/O	AL25	K42
I/O	AJ23	K40
I/O	AN26	L43
I/O	AL24	L41
GND	GND*	GND*
I/O	AK23	R37
I/O	AN25	P42
I/O	AJ22	T36
I/O	AL23	N39
VCC	VCC*	VCC*
I/O	AM24	M40
I/O	AK22	R43
I/O	AM23	N41
I/O	AJ21	R39
GND	GND*	GND*
I/O	AL22	U37
I/O	AN23	T42
I/O	AK21	P40
I/O	AM22	U43
I/O	AJ20	R41
I/O	AL21	V42
I/O	AN21	U39
I/O	AK20	V38
GND	GND*	GND*
VCC	VCC*	VCC*
I/O	AL20	W37
I/O	AJ19	T40
I/O	AM20	Y42
I/O	AK19	U41
I/O	AL19	Y36
I/O	AN19	V40
GND	GND*	GND*
I/O	AJ18	W39
I/O	AK18	AA43
I/O	AL18	Y38
I/O	AM18	Y40
I/O	AK17	AA37
I/O (INIT)	AJ17	AA39
VCC	VCC*	VCC*
GND	GND*	GND*
I/O	AL17	AA41
I/O	AM17	AB38
I/O	AN17	AB42
I/O	AK16	AB40
I/O	AJ16	AC37
I/O	AL16	AC39
GND	GND*	GND*
I/O	AM16	AD36
I/O	AL15	AC41
I/O	AK15	AD38
I/O	AJ15	AC43
I/O	AN15	AD40
I/O	AM14	AE39
VCC	VCC*	VCC*
GND	GND*	GND*
I/O	AL14	AE37
I/O	AK14	AF40
I/O	AJ14	AD42
I/O	AN13	AF42
I/O	AM13	AF38
I/O	AL13	AG39
I/O	AK13	AG43
I/O	AJ13	AG37
GND	GND*	GND*
I/O	AM12	AH40
I/O	AL12	AJ41
I/O	AK12	AG41
I/O	AN11	AK40
VCC	VCC*	VCC*
I/O	AJ12	AJ39

XC4000E and XC4000X Series Field Programmable Gate Arrays

XC4085XL Pad Name	BG560	PG559
I/O	AL11	AH42
I/O	AK11	AH36
I/O	AM10	AL39
GND	GND*	GND*
I/O	AL10	AJ37
I/O	AJ11	AJ43
I/O	AN9	AM40
I/O	AK10	AK42
I/O	AM9	AN41
I/O	AL9	AL41
I/O	AJ10	AR41
I/O	AM8	AK36
GND	GND*	GND*
VCC	VCC*	VCC*
I/O	AK9	AL37
I/O	AL8	AN43
I/O	AN7	AM38
I/O	AJ9	AP42
I/O	AL7	AN39
I/O	AK8	AR43
I/O	AN6	AP40
I/O	AM6	AT40
GND	GND*	GND*
VCC	VCC*	VCC*
I/O	AJ8	AN37
I/O	AL6	AR39
I/O	AK7	AT42
I/O	AM5	BA43
I/O	AM4	AU43
I/O	AJ7	AU39
GND	GND*	GND*
I/O	AL5	AT38
I/O	AK6	AP36
I/O	AN3	AR37
I/O	AK5	AV42
I/O	AJ6	AV40
I/O, GCK4	AL4	AW41
GND	GND*	GND*
DONE	AJ5	AY42
VCC	VCC*	VCC*
PROGRAM	AM1	BB42
I/O (D7)	AH5	BC41
I/O, GCK5	AJ4	AV38
I/O	AK3	BA39
I/O	AH4	AT36
I/O	AL1	BB40
I/O	AG5	AY40
GND	GND*	GND*
I/O	AJ3	BA41
I/O	AK2	BB38
I/O	AG4	AY38
I/O	AH3	BC37
I/O	AF5	AW37
I/O	AJ2	AT34
VCC	VCC*	VCC*
GND	GND*	GND*
I/O (D6)	AJ1	AU35
I/O	AF4	AV36
I/O	AG3	BB36
I/O	AE5	AY36
I/O	AH1	BC35
I/O	AF3	AW35
I/O	AE4	AU33
I/O	AG2	AT30
VCC	VCC*	VCC*
GND	GND*	GND*
I/O	AD5	AV32
I/O	AF2	AU31
I/O	AF1	AW33
I/O	AD4	BB34

XC4085XL Pad Name	BG560	PG559
I/O	AE3	AY34
I/O	AC5	BC33
I/O	AE1	AU29
I/O	AD3	AT28
GND	GND*	GND*
I/O	AC4	BA35
I/O	AD2	BB30
I/O	AB5	AW31
I/O	AC3	AY32
VCC	VCC*	VCC*
I/O	AB4	BA33
I/O	AC1	AU27
I/O (D5)	AA5	BC29
I/O (CS0)	AB3	AW29
GND	GND*	GND*
I/O	AB2	AY30
I/O	AA4	BA31
I/O	AA3	BB28
I/O	Y5	AW27
I/O	AA1	BC27
I/O	Y4	AV26
I/O	Y3	AU25
I/O	Y2	AY28
GND	GND*	GND*
VCC	VCC*	VCC*
I/O	W5	BA29
I/O	W4	AT24
I/O	W3	BB26
I/O	W1	AW25
I/O	V3	BB24
I/O	V5	AY26
GND	GND*	GND*
I/O	V4	AV24
I/O	V2	AU23
I/O	U2	BA27
I/O	U1	BC23
I/O (D4)	U5	AY24
I/O	U4	AW23
VCC	VCC*	VCC*
GND	GND*	GND*
I/O (D3)	U3	BA23
I/O (RS)	T2	AV22
I/O	T3	AY22
I/O	T5	BB22
I/O	T4	AU21
I/O	R1	AW21
GND	GND*	GND*
I/O	R3	BA21
I/O	R4	BC21
I/O	R5	AY20
I/O	P2	BB20
I/O	P3	AT20
I/O	P4	AV20
VCC	VCC*	VCC*
GND	GND*	GND*
I/O	N1	AW19
I/O	P5	AY18
I/O	N2	BB18
I/O	N3	AU19
I/O	N4	BC17
I/O	M2	BA17
I/O	N5	AV18
I/O	M3	AW17
GND	GND*	GND*
I/O (D2)	M4	AY16
I/O	L1	BB16
I/O	L3	AU17
I/O	M5	BA15
VCC	VCC*	VCC*
I/O	K2	AW15

XC4085XL Pad Name	BG560	PG559
I/O	L4	BC15
I/O	J1	AY14
I/O	K3	BA13
GND	GND*	GND*
I/O	L5	AT16
I/O	J2	BB14
I/O	K4	AU15
I/O	J3	BC11
I/O	H2	AW13
I/O	K5	BB10
I/O	H3	AY12
I/O	J4	BA11
GND	GND*	GND*
VCC	VCC*	VCC*
I/O	G1	AT14
I/O	F1	AU13
I/O	J5	AV12
I/O	G3	BC9
I/O	H4	AW11
I/O	F2	BB8
I/O	E2	AY10
I/O	H5	AU11
GND	GND*	GND*
VCC	VCC*	VCC*
I/O (D1)	F3	BA9
I/O (RCLK RDY/BUSY)	G4	AW9
I/O	D2	BC7
I/O	E3	AY8
I/O	G5	AV8
I/O	C1	AT10
GND	GND*	GND*
I/O	F4	AU9
I/O	D3	BB6
I/O	B3	AW7
I/O	F5	BC3
I/O (D0, DIN)	E4	AY6
I/O, GCK6 (DOUT)	D4	BB4
CCLK	C4	BA5
VCC	VCC*	VCC*
O, TDO	E6	BA3
GND	GND*	GND*
I/O (A0, WS)	D5	AT8
I/O, GCK7 (A1)	A2	AV6
I/O	D6	BB2
I/O	A3	AY4
I/O	E7	AR7
I/O	C5	AP8
GND	GND*	GND*
I/O	B4	AT6
I/O	D7	AY2
I/O (CS1, A2)	C6	AU5
I/O (A3)	E8	BA1
I/O	B5	AV4
I/O	A5	AW3
VCC	VCC*	VCC*
GND	GND*	GND*
I/O	D8	AN7
I/O	C7	AR5
I/O	E9	AV2
I/O	A6	AT4
I/O	B7	AU1
I/O	D9	AR3
I/O	C8	AT2
I/O	E10	AL7
VCC	VCC*	VCC*
GND	GND*	GND*
I/O	B8	AK8
I/O	A8	AM6
I/O	D10	AN5

XC4085XL Pad Name	BG560	PG559
I/O	C9	AR1
I/O	E11	AP4
I/O	A9	AN3
I/O	C10	AP2
I/O	D11	AJ7
GND	GND*	GND*
I/O	B10	AH8
I/O	E12	AL5
I/O	C11	AN1
I/O	B11	AM4
VCC	VCC*	VCC*
I/O	D12	AL3
I/O	A11	AJ5
I/O	E13	AK2
I/O	C12	AG7
GND	GND*	GND*
I/O	B12	AK4
I/O	D13	AJ3
I/O	C13	AG5
I/O	E14	AJ1
I/O	A13	AF6
I/O	D14	AH2
I/O	C14	AE7
I/O	B14	AH4
GND	GND*	GND*
VCC	VCC*	VCC*
I/O (A4)	E15	AG3
I/O (A5)	D15	AD8
I/O	C15	AG1
I/O	A15	AF4
I/O (A21)	C16	AE5
I/O (A20)	E16	AD6
GND	GND*	GND*
I/O	D16	AD4
I/O	B16	AF2
I/O	B17	AC7
I/O	C17	AD2
I/O (A6)	E17	AC5
I/O (A7)	D17	AC3
GND	GND*	GND*

6/13/97

Additional XC4085XL Package Pins

BG560

VCC Pins						
A4	A10	A16	A22	A26	A30	B2
B13	B19	B32	C3	C31	C32	D1
D33	E5	H1	K33	M1	N32	R2
T33	V1	W32	AA2	AB33	AD1	AF33
AK1	AK4	AK33	AL2	AL3	AL31	AM2
AM15	AM21	AM32	AN4	AN8	AN12	AN18
AN24	AN30	-	-	-	-	-
GND Pins						
A7	A12	A14	A18	A20	A24	A29
A32	B1	B6	B9	B15	B23	B27
B31	C2	E1	F32	G2	G33	J32
K1	L2	M33	P1	P33	R32	T1
V33	W2	Y1	Y33	AB1	AC32	AD33
AE2	AG1	AG32	AH2	AJ33	AL32	AM3
AM11	AM19	AM25	AM28	AM33	AM7	AN2
AN5	AN10	AN14	AN16	AN20	AN22	AN27
N.C. Pins						
A1	A33	AC2	AN1	AN33	-	-

6/4/97

PG559

VCC Pins						
A13	A31	A43	B2	C7	C19	C25
C37	F14	F30	G3	G7	G37	G41
H12	H18	H26	H32	M8	M36	N1
N43	P6	P38	V8	V36	W3	W41
AE3	AE41	AF8	AF36	AK6	AK38	AL1
AL43	AM8	AM36	AT12	AT18	AT26	AT32
AU3	AU7	AU37	AU41	AV14	AV30	BA7
BA19	BA25	BA37	BC1	BC13	BC31	BC43
GND Pins						
A5	A19	A25	A39	B12	B32	E1
E5	E39	E43	F10	F16	F28	F34
H22	K6	K38	M2	M42	T6	T38
W1	W43	AB8	AB36	AE1	AE43	AH6
AH38	AM2	AM42	AP6	AP38	AT22	AV10
AV16	AV28	AV34	AW1	AW5	AW39	AW43
BB12	BB32	BC5	BC19	BC25	BC39	-

5/8/97

* Pads labelled GND* or VCC* are internally bonded to Ground or VCC planes within the package. They have no direct connection to any specific package pin.

† = E only, †† = XL only

Product Availability

Table 24 - Table 26 show the planned packages and speed grades for XC4000-Series devices. Call your local sales office for the latest availability information, or see the Xilinx WEBLINX at <http://www.xilinx.com> for the latest revision of the specifications.

Table 24: Component Availability Chart for XC4000XL FPGAs

	PINS	84	100	100	144	144	160	160	176	176	208	208	240	240	256	299	304	352	411	432	475	599	560	
		TYPE	Plast. PLCC	Plast. PQFP	Plast. VQFP	Plast. TQFP	High-Perf. TQFP	High-Perf. QFP	Plast. PQFP	Plast. TQFP	High-Perf. TQFP	High-Perf. QFP	Plast. PQFP	High-Perf. QFP	Plast. PQFP	Plast. BGA	Ceram. PGA	High-Perf. QFP	Plast. BGA	Ceram. PGA	Plast. BGA	Ceram. PGA	Ceram. PGA	Plast. BGA
		CODE	PC84	PQ100	VQ100	TQ144	HT144	HQ160	PQ160	TQ176	HT176	HQ208	PQ208	HQ240	PQ240	BG256	PG299	HQ304	BG352	PG411	BG432	PG475	PG599	BG560
XC4005XL	-3	C	C	C	C			C				C												
	-2	C	C	C	C			C				C												
	-1	C	C	C	C			C				C												
XC4010XL	-3	C	C		C			C	C			C						C						
	-2	C	C		C			C	C			C						C						
	-1	C	C		C			C	C			C						C						
XC4013XL	-3					C		C		C		C			C		C							
	-2					C		C		C		C			C		C							
	-1					C		C		C		C			C		C							
XC4020XL	-3					C		C		C		C			C		C							
	-2					C		C		C		C			C		C							
	-1					C		C		C		C			C		C							
XC4028XL	-3						C				C		C		C	C	C	C						
	-2						C				C		C		C	C	C	C						
	-1						C				C		C		C	C	C	C						
XC4036XL	-3						C				C		C				C	C	C	C				
	-2						C				C		C				C	C	C	C				
	-1						C				C		C				C	C	C	C				
XC4044XL	-3						C				C		C				C	C	C	C				
	-2						C				C		C				C	C	C	C				
	-1						C				C		C				C	C	C	C				
XC4052XL	-3											C					C		C	C				C
	-2											C					C		C	C				C
	-1											C					C		C	C				C
XC4062XL	-3											C					C			C	C			C
	-2											C					C			C	C			C
	-1											C					C			C	C			C
XC4085XL	-3																						C	C
	-2																						C	C
	-1																						C	C

8/4/97

C = Commercial $T_J = 0^\circ$ to $+85^\circ\text{C}$

I = Industrial $T_J = -40^\circ\text{C}$ to $+100^\circ\text{C}$

Table 25: Component Availability Chart for XC4000E FPGAs

	PINS	84	100	100	120	144	156	160	191	208	208	223	225	240	240	299	304	
		TYPE	Plast. PLCC	Plast. PQFP	Plast. VQFP	Ceram. PGA	Plast. TQFP	Ceram. PGA	Plast. PQFP	Ceram. PGA	High-Perf. QFP	Plast. PQFP	Ceram. PGA	Plast. BGA	High-Perf. QFP	Plast. PQFP	Ceram. PGA	High-Perf. QF
		CODE	PC84	PQ100	VQ100	PG120	TQ144	PG156	PQ160	PG191	HQ208	PQ208	PG223	BG225	HQ240	PQ240	PG299	HQ304
XC4003E	-4	C I	C I	C I	C I													
	-3	C	C	C	C													
	-2	C	C	C	C													
	-1	C	C	C	C													
XC4005E	-4	C I	C I			C I	C I	C I			C I							
	-3	C	C			C	C	C			C							
	-2	C	C			C	C	C			C							
	-1	C	C			C	C	C			C							
XC4006E	-4	C I				C I	C I	C I			C I							
	-3	C				C	C	C			C							
	-2	C				C	C	C			C							
	-1	C				C	C	C			C							
XC4008E	-4	C I						C I	C I		C I							
	-3	C						C	C		C							
	-2	C						C	C		C							
	-1	C						C	C		C							
XC4010E	-4	C I						C I	C I	C I	C I		C I					
	-3	C						C	C	C	C		C					
	-2	C						C	C	C	C		C					
	-1	C						C	C	C	C		C					
XC4013E	-4							C I		C I	C I	C I	C I	C I	C I			
	-3							C		C	C	C	C	C	C			
	-2							C		C	C	C	C	C	C			
	-1							C		C	C	C	C	C	C			
XC4020E	-4									C I		C I		C I				
	-3									C		C		C				
	-2									C		C		C				
	-1									C		C		C				
XC4025E	-4										C I		C I		C I	C I		
	-3										C		C		C	C		
	-2										C		C		C	C		

8/4/97

C = Commercial $T_J = 0^\circ$ to $+85^\circ\text{C}$

I = Industrial $T_J = -40^\circ\text{C}$ to $+100^\circ\text{C}$

Table 26: Component Availability Chart for XC4000EX FPGAs

	PINS	208	240	299	304	352	411	432	
		TYPE	High-Perf. QFP	High-Perf. QFP	Ceram. PGA	High-Perf. QFP	Plast. BGA	Ceram. PGA	Plast. BGA
		CODE	HQ208	HQ240	PG299	HQ304	BG352	PG411	BG432
XC4028EX	-3	C I	C I	C I	C I	C I			
	-2	C	C	C	C	C			
	-1	C	C	C	C	C			
XC4036EX	-3				C I		C I	C I	
	-2				C		C	C	
	-1				C		C	C	

8/4/97

C = Commercial $T_J = 0^\circ$ to $+85^\circ\text{C}$

I = Industrial $T_J = -40^\circ\text{C}$ to $+100^\circ\text{C}$

User I/O Per Package

Table 27 - Table 29 show the number of user I/Os available in each package for XC4000-Series devices. Call your local sales office for the latest availability information, or see the Xilinx WEBLIXX at <http://www.xilinx.com> for the latest revision of the specifications.

Table 27: User I/O Chart for XC4000XL FPGAs

Device	Max I/O	Package Type																						
		PC84	PQ100	VQ100	TQ144	HT144	HQ160	PQ160	TQ176	HT176	HQ208	PQ208	HQ240	PQ240	BG256	PG299	HQ304	BG352	PG411	BG432	PG475	PG599	BG560	
XC4005XL	112	61	77	77	112			112				112												
XC4010XL	160	61	77		113			129	145			160			160									
XC4013XL	192					113		129		145		160		192	192									
XC4020XL	224					113		129		145		160		193	205									
XC4028XL	256							129				160		193		205	256	256	256					
XC4036XL	288							129				160		193				256	288	288	288			
XC4044XL	320							129				160		193				256	289	320	320			
XC4052XL	352													193				256		352	352			352
XC4062XL	384													193				256			352	384		384
XC4085XL	448																						448	448
XC40125XV	448																						448	432

9/30/97

Table 28: User I/O Chart for XC4000E FPGAs

Device	Max I/O	Package Type															
		PC84	PQ100	VQ100	PG120	TQ144	PG156	PQ160	PG191	HQ208	PQ208	PG223	BG225	HQ240	PQ240	PG299	HQ304
XC4003E	80	61	77	77	80												
XC4005E	112	61	77			112	112	112				112					
XC4006E	128	61				113	125	128				128					
XC4008E	144	61						129	144			144					
XC4010E	160	61						129	160	160	160		160				
XC4013E	192							129		160	160	192	192	192	192		
XC4020E	224									160		192		193			
XC4025E	256											192		193		256	256

8/5/97

Table 29: User I/O Chart for XC4000EX FPGAs

Device	Max I/O	Package Type						
		HQ208	HQ240	PG299	HQ304	BG352	PG411	BG432
XC4028EX	256	160	193	256	256	256		
XC4036EX	288		193		256	288	288	288

8/5/97

Ordering Information

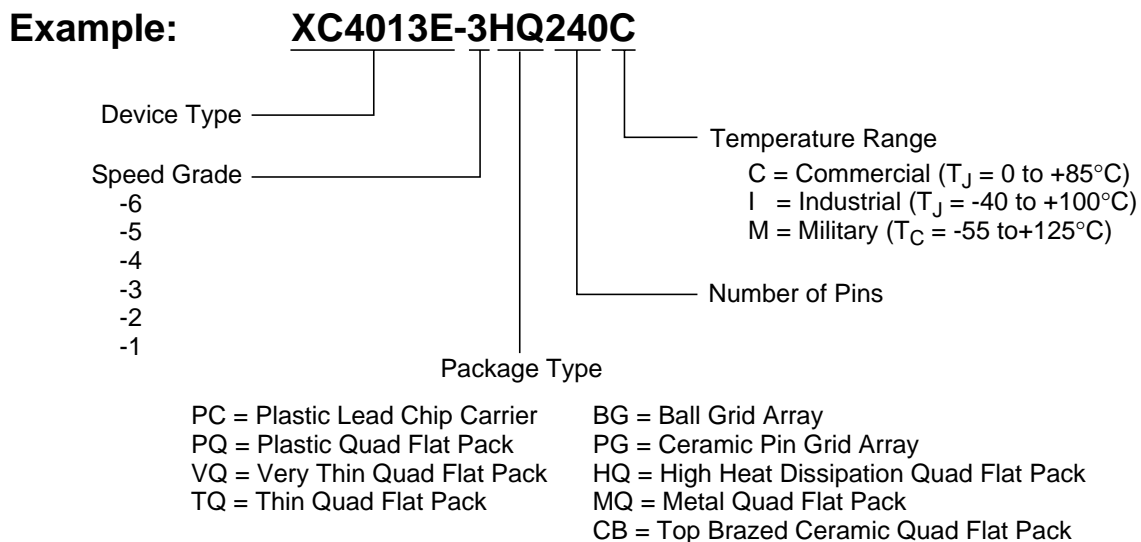

X9020

 **The Programmable Logic CompanySM****Headquarters**

Xilinx, Inc.
2100 Logic Drive
San Jose, CA 95124
U.S.A.
Tel: 1 (800) 255-7778
or 1 (408) 559-7778
Fax: 1 (800) 559-7114
Net: hotline@xilinx.com
Web: <http://www.xilinx.com>

North America

Irvine, California
(714) 727-0780

Englewood, Colorado
(303)220-7541

Sunnyvale, California
(408) 245-9850

Schaumburg, Illinois
(847) 605-1972

Nashua, New Hampshire
(603) 891-1098

Raleigh, North Carolina
(919) 846-3922

West Chester, Pennsylvania
(610) 430-3300

Dallas, Texas
(214) 960-1043

Europe

Xilinx Sarl
Jouy en Josas, France
Tel: (33) 1-34-63-01-01
Net: frhelp@xilinx.com

Xilinx GmbH
Aschheim, Germany
Tel: (49) 89-99-1549-01
Net: dlhelp@xilinx.com

Xilinx, Ltd.
Byfleet, United Kingdom
Tel: (44) 1-932-349401
Net: ukhelp@xilinx.com

Japan

Xilinx, K.K.
Tokyo, Japan
Tel: (03) 3297-9191

Asia Pacific

Xilinx Asia Pacific
Hong Kong
Tel: (852) 2424-5200
Net: hongkong@xilinx.com

© 1996 Xilinx, Inc. All rights reserved. The Xilinx name and the Xilinx logo are registered trademarks, all XC-designated products are trademarks, and the Programmable Logic Company is a service mark of Xilinx, Inc. All other trademarks and registered trademarks are the property of their respective owners.

Xilinx, Inc. does not assume any liability arising out of the application or use of any product described herein; nor does it convey any license under its patent, copyright or maskwork rights or any rights of others. Xilinx, Inc. reserves the right to make changes, at any time, in order to improve reliability, function or design and to supply the best product possible. Xilinx, Inc. cannot assume responsibility for the use of any circuitry described other than circuitry entirely embodied in its products. Products are manufactured under one or more of the following U.S. Patents: (4,847,612; 5,012,135; 4,967,107; 5,023,606; 4,940,909; 5,028,821; 4,870,302; 4,706,216; 4,758,985; 4,642,487; 4,695,740; 4,713,557; 4,750,155; 4,821,233; 4,746,822; 4,820,937; 4,783,607; 4,855,669; 5,047,710; 5,068,603; 4,855,619; 4,835,418; and 4,902,910. Xilinx, Inc. cannot assume responsibility for any circuits shown nor represent that they are free from patent infringement or of any other third party right. Xilinx, Inc. assumes no obligation to correct any errors contained herein or to advise any user of this text of any correction if such be made.