

Detailed Description

Input/Output Blocks (IOBs)

Virtex-II I/O blocks (IOBs) are provided in groups of two or four on the perimeter of each device. Each IOB can be used as input and/or output for single-ended I/Os. Two IOBs can be used as a differential pair. A differential pair is always connected to the same switch matrix, as shown in [Figure 1](#).

IOB blocks are designed for high performances I/Os, supporting 19 single-ended standards, as well as differential signaling with LVDS, LDT, Bus LVDS, and LVPECL.

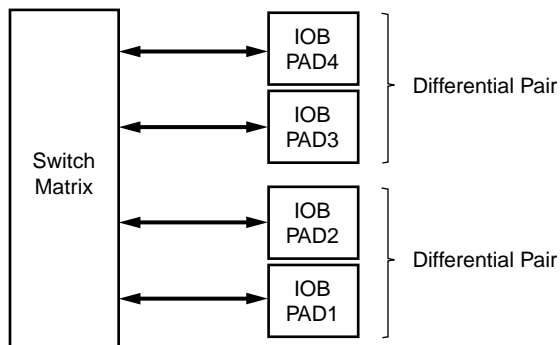

DS031_30_101600

Figure 1: Virtex-II Input/Output Tile

Supported I/O Standards

Virtex-II IOB blocks feature SelectI/O inputs and outputs that support a wide variety of I/O signaling standards. In addition to the internal supply voltage ($V_{CCINT} = 1.5V$), output driver supply voltage (V_{CCO}) is dependent on the I/O standard (see [Table 1](#)). An auxiliary supply voltage ($V_{CCAUX} = 3.3V$) is required, regardless of the I/O standard used. For exact supply voltage absolute maximum ratings, see [DC Input and Output Levels](#).

Table 1: Supported Single-Ended I/O Standards

I/O Standard	Output V_{CCO}	Input V_{CCO}	Input V_{REF}	Board Termination Voltage (V_{TT})
LVTTTL	3.3	3.3	N/A	N/A
LVC MOS33	3.3	3.3	N/A	N/A
LVC MOS25	2.5	2.5	N/A	N/A
LVC MOS18	1.8	1.8	N/A	N/A
LVC MOS15	1.5	1.5	N/A	N/A
PCI33_3	3.3	3.3	N/A	N/A
PCI66_3	3.3	3.3	N/A	N/A
PCI-X	3.3	3.3	N/A	N/A
GTL	Note 1	Note 1	0.8	1.2
GTL P	Note 1	Note 1	1.0	1.5
HSTL_I	1.5	N/A	0.75	0.75
HSTL_II	1.5	N/A	0.75	0.75
HSTL_III	1.5	N/A	0.9	1.5
HSTL_IV	1.5	N/A	0.9	1.5
SSTL2_I	2.5	N/A	1.25	1.25
SSTL2_II	2.5	N/A	1.25	1.25
SSTL3_I	3.3	N/A	1.5	1.5
SSTL3_II	3.3	N/A	1.5	1.5
AGP-2X/AGP	3.3	N/A	1.32	N/A

Notes:

- V_{CCO} of GTL or GTLP should not be lower than the termination voltage or the voltage seen at the I/O pad.

Table 2: Supported Differential Signal I/O Standards

I/O Standard	Output V _{CCO}	Input V _{CCO}	Input V _{REF}	Output V _{OD}
LVPECL_33	3.3	N/A	N/A	V _{CCO} - 1.025 to V _{CCO} - 1.64
LDT_25	2.5	N/A	N/A	0.430 - 0.670
LVDS_33	3.3	N/A	N/A	0.250 - 0.400
LVDS_25	2.5	N/A	N/A	0.250 - 0.400
LVDSEXT_33	3.3	N/A	N/A	0.330 - 0.700
LVDSEXT_25	2.5	N/A	N/A	0.330 - 0.700
BLVDS_25	2.5	N/A	N/A	0.250 - 0.450
ULVDS_25	2.5	N/A	N/A	0.430 - 0.670

All of the user IOBs have fixed-clamp diodes to V_{CCO} and to ground. The IOBs are not compatible or compliant with 5 V I/O standards (not 5 V tolerant).

Table 3 lists supported I/O standards with Digitally Controlled Impedance. See **Digitally Controlled Impedance (DCI)**, page 6.

Table 3: Supported DCI I/O Standards

I/O Standard	Output V _{CCO}	Input V _{CCO}	Input V _{REF}	Termination Type
LVDCI_33 ⁽¹⁾	3.3	3.3	N/A	Series
LVDCI_DV2_33 ⁽¹⁾	3.3	3.3	N/A	Series
LVDCI_25 ⁽¹⁾	2.5	2.5	N/A	Series
LVDCI_DV2_25 ⁽¹⁾	2.5	2.5	N/A	Series
LVDCI_18 ⁽¹⁾	1.8	1.8	N/A	Series
LVDCI_DV2_18 ⁽¹⁾	1.8	1.8	N/A	Series
LVDCI_15 ⁽¹⁾	1.5	1.5	N/A	Series
LVDCI_DV2_15 ⁽¹⁾	1.5	1.5	N/A	Series
GTL_DCI	1.2	1.2	0.8	Single
GTL_P_DCI	1.5	1.5	1.0	Single
HSTL_I_DCI	1.5	1.5	0.75	Split
HSTL_II_DCI	1.5	1.5	0.75	Split
HSTL_III_DCI	1.5	1.5	0.9	Single
HSTL_IV_DCI	1.5	1.5	0.9	Single
SSTL2_I_DCI ⁽²⁾	2.5	2.5	1.25	Split
SSTL2_II_DCI ⁽²⁾	2.5	2.5	1.25	Split
SSTL3_I_DCI ⁽²⁾	3.3	3.3	1.5	Split
SSTL3_II_DCI ⁽²⁾	3.3	3.3	1.5	Split

Notes:

1. LVDCI_XX and LVDCI_DV2_XX are LVCMOS controlled impedance buffers, matching the reference resistors or half of the reference resistors.
2. These are SSTL compatible.

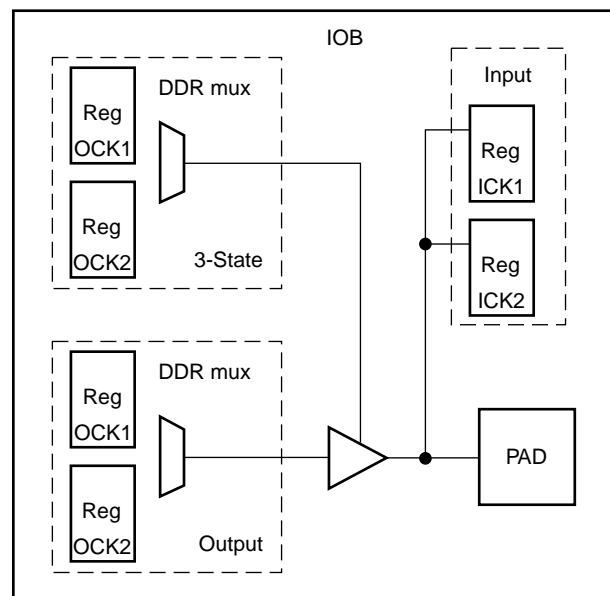

DS031_29_100900

Figure 2: Virtex-II IOB Block

Double data rate is directly accomplished by the two registers on each path, clocked by the rising edges (or falling edges) from two different clock nets. The two clock signals

are generated by the DCM and must be 180 degrees out of phase, as shown in Figure 3. There are two input, output, and 3-state data signals, each being alternately clocked out.

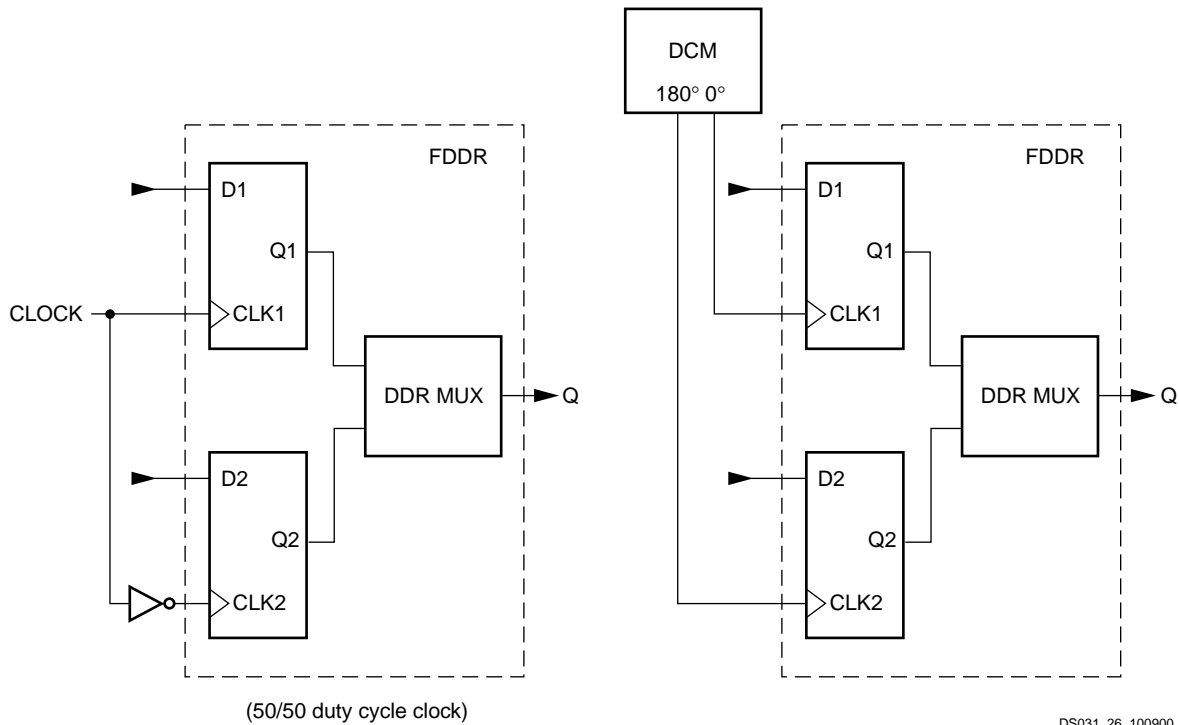

Figure 3: Double Data Rate Registers

This DDR mechanism can be used to mirror a copy of the clock on the output. This is useful for propagating a clock along the data that has an identical delay. It is also useful for multiple clock generation, where there is a unique clock driver for every clock load. Virtex-II devices can produce many copies of a clock with very little skew.

Each group of two registers has a clock enable signal (ICE for the input registers, OCE for the output registers, and TCE for the 3-state registers). The clock enable signals are active High by default. If left unconnected, the clock enable for that storage element defaults to the active state.

Each IOB block has common synchronous or asynchronous set and reset (SR and REV signals).

SR forces the storage element into the state specified by the SRHIGH or SRLow attribute. SRHIGH forces a logic "1". SRLow forces a logic "0". When SR is used, a second input (REV) forces the storage element into the opposite state. The reset condition predominates over the set condition. The initial state after configuration or global initialization state is defined by a separate INIT0 and INIT1 attribute. By default,

the SRLow attribute forces INIT0, and the SRHIGH attribute forces INIT1.

For each storage element, the SRHIGH, SRLow, INIT0, and INIT1 attributes are independent. Synchronous or asynchronous set / reset is consistent in an IOB block.

All the control signals have independent polarity. Any inverter placed on a control input is automatically absorbed.

Each register or latch (independent of all other registers or latches) (see Figure 4) can be configured as follows:

- No set or reset
- Synchronous set
- Synchronous reset
- Synchronous set and reset
- Asynchronous set (preset)
- Asynchronous reset (clear)
- Asynchronous set and reset (preset and clear)

The synchronous reset overrides a set, and an asynchronous clear overrides a preset.

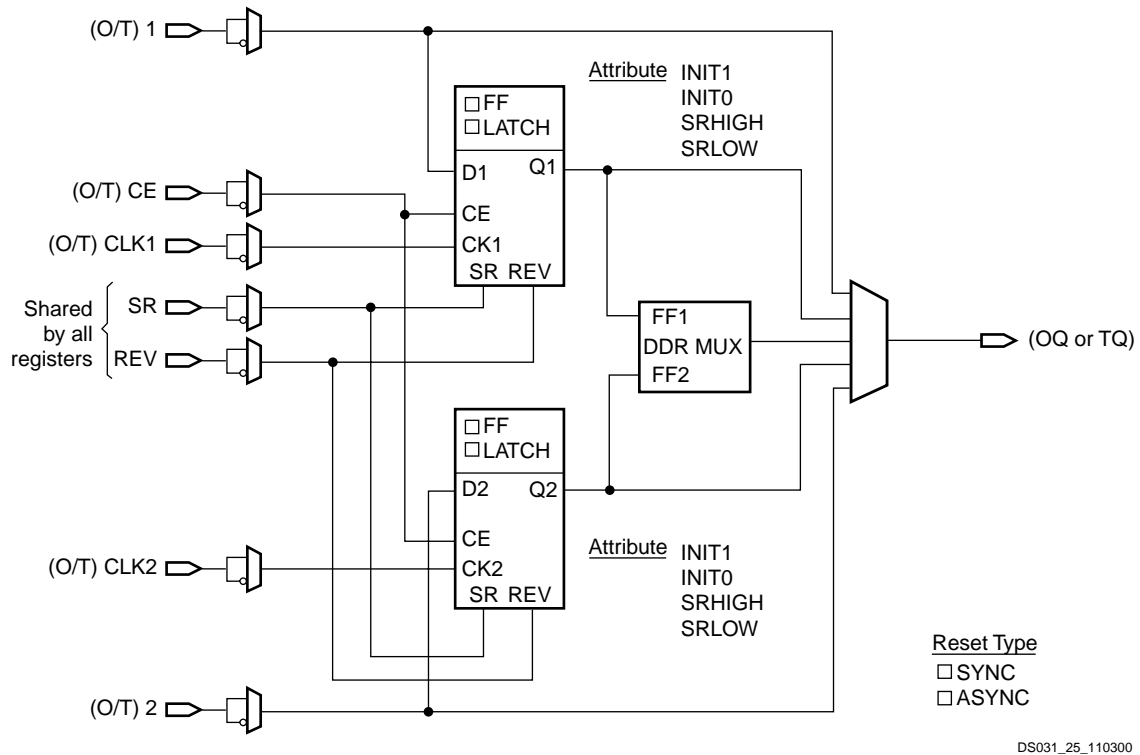

Figure 4: Register / Latch Configuration in an IOB Block

Input/Output Individual Options

Each device pad has optional pull-up, pull-down, and weak-keeper in LVTTTL and LVCMOS Select/O configurations, as illustrated in Figure 5. Values of the optional

pull-up and pull-down resistors are in the range 10 - 60 K Ω , which is the specification for V_{CCO} when operating at 3.3 V (from 3.0 to 3.6 V only).

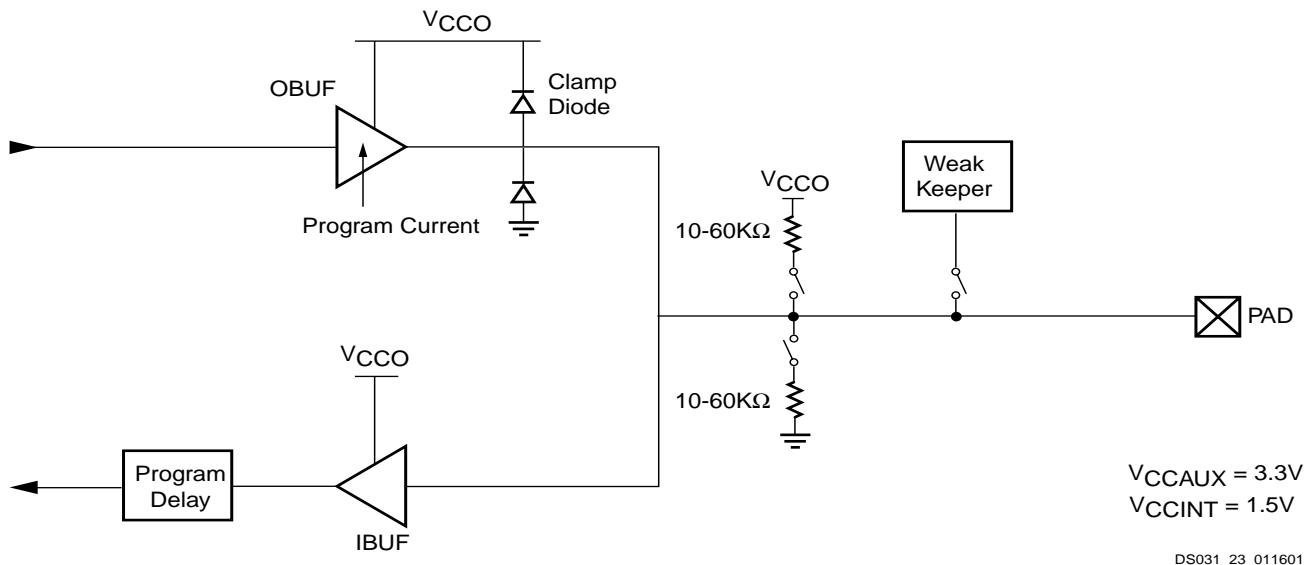

Figure 5: LVTTTL, LVCMOS or PCI Select/O Standards

The optional weak-keeper circuit is connected to each output. When selected, the circuit monitors the voltage on the pad and weakly drives the pin High or Low. If the pin is con-

nected to a multiple-source signal, the weak-keeper holds the signal in its last state if all drivers are disabled. Maintain-

ing a valid logic level in this way eliminates bus chatter; pull-up or pull-down override the weak-keeper circuit.

LVTTL sinks and sources current up to 24 mA. The current is programmable for LVTTL and LVCMOS SelectI/O stan-

dards (see Table 4). Drive-strength and slew-rate controls for each output driver, minimize bus transients. For LVDCI and LVDCI_DV2 standards, drive strength and slew-rate controls are not available.

Table 4: LVTTL and LVCMOS Programmable Currents (Sink and Source)

SelectI/O	Programmable Current (Worst-Case Guaranteed Minimum)						
LVTTL	2 mA	4 mA	6 mA	8 mA	12 mA	16 mA	24 mA
LVCMOS33	2 mA	4 mA	6 mA	8 mA	12 mA	16 mA	24 mA
LVCMOS25	2 mA	4 mA	6 mA	8 mA	12 mA	16 mA	24 mA
LVCMOS18	2 mA	4 mA	6 mA	8 mA	12 mA	16 mA	n/a
LVCMOS15	2 mA	4 mA	6 mA	8 mA	12 mA	16 mA	n/a

Figure 6 shows the SSTL2, SSTL3, and HSTL configurations. HSTL can sink current up to 48 mA. (HSTL IV)

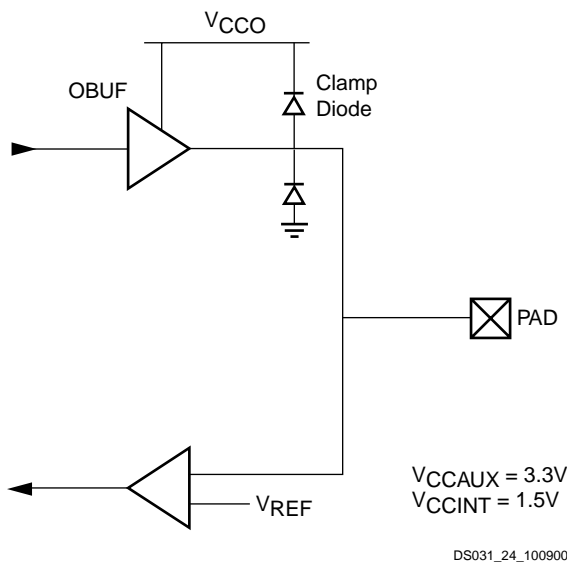

Figure 6: SSTL or HSTL SelectI/O Standards

All pads are protected against damage from electrostatic discharge (ESD) and from over-voltage transients. Virtex-II uses two memory cells to control the configuration of an I/O as an input. This is to reduce the probability of an I/O configured as an input from flipping to an output when subjected to a single event upset (SEU) in space applications.

Prior to configuration, all outputs not involved in configuration are forced into their high-impedance state. The pull-down resistors and the weak-keeper circuits are inactive. The dedicated pin HSWAP_EN controls the pull-up resistors prior to configuration. By default, HSWAP_EN is set high, which disables the pull-up resistors on user I/O pins. When HSWAP_EN is set low, the pull-up resistors are activated on user I/O pins.

All Virtex-II IOBs support IEEE 1149.1 compatible boundary scan testing.

Input Path

The Virtex-II IOB input path routes input signals directly to internal logic and / or through an optional input flip-flop or latch, or through the DDR input registers. An optional delay element at the D-input of the storage element eliminates pad-to-pad hold time. The delay is matched to the internal clock-distribution delay of the Virtex-II device, and when used, assures that the pad-to-pad hold time is zero.

Each input buffer can be configured to conform to any of the low-voltage signaling standards supported. In some of these standards the input buffer utilizes a user-supplied threshold voltage, VREF. The need to supply VREF imposes constraints on which standards can be used in the same bank. See I/O banking description.

Output Path

The output path includes a 3-state output buffer that drives the output signal onto the pad. The output and / or the 3-state signal can be routed to the buffer directly from the internal logic or through an output / 3-state flip-flop or latch, or through the DDR output / 3-state registers.

Each output driver can be individually programmed for a wide range of low-voltage signaling standards. In most signaling standards, the output High voltage depends on an externally supplied VCCO voltage. The need to supply VCCO imposes constraints on which standards can be used in the same bank. See I/O banking description.

I/O Banking

Some of the I/O standards described above require VCCO and VREF voltages. These voltages are externally supplied and connected to device pins that serve groups of IOB blocks, called banks. Consequently, restrictions exist about which I/O standards can be combined within a given bank.

Eight I/O banks result from dividing each edge of the FPGA into two banks, as shown in Figure 7 and Figure 8. Each bank has multiple VCCO pins, all of which must be con-

nected to the same voltage. This voltage is determined by the output standards in use.

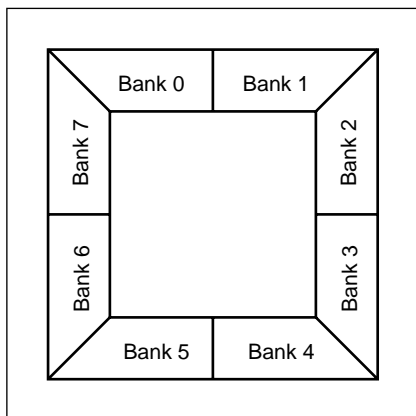

ug002_c2_014_112900

Figure 7: Virtex-II I/O Banks: Top View for Wire-Bond Packages (CS, FG, & BG)

Within a bank, output standards can be mixed only if they use the same V_{CCO} . Compatible standards are shown in Table 5. GTL and GTLP appear under all voltages because their open-drain outputs do not depend on V_{CCO} .

Some input standards require a user-supplied threshold voltage, V_{REF} . In this case, certain user-I/O pins are automatically configured as inputs for the V_{REF} voltage. Approximately one in six of the I/O pins in the bank assume this role.

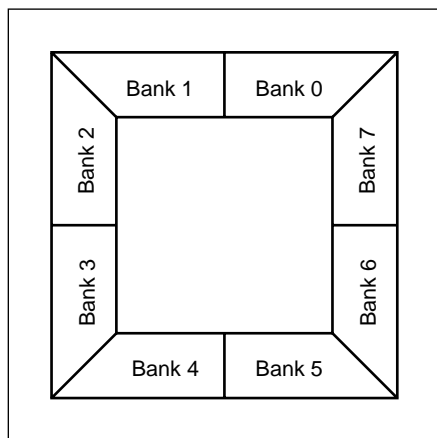

ds031_66_112900

Figure 8: Virtex-II I/O Banks: Top View for Flip-Chip Packages (FF & BF)

V_{REF} pins within a bank are interconnected internally, and consequently only one V_{REF} voltage can be used within each bank. However, for correct operation, all V_{REF} pins in

the bank must be connected to the external reference voltage source.

Table 5: Compatible Output Standards

V_{CCO}	Compatible Standards
3.3 V	PCI, LVTTTL, SSTL3 (I & II), AGP-2X, LVDS_33, LVDSEXT_33, LVCMOS33, LVDCI_33, LVDCI_DV2_33, SSTL3_DCI (I & II), BLVDS, LVPECL, GTL, GTLP
2.5 V	SSTL2 (I & II), LVCMOS25, GTL, GTLP, LVDS_25, LVDSEXT_25, LVDCI_25, LVDCI_DV2_25, SSTL2_DCI (I & II), LDT, ULVDS, BLVDS
1.8 V	LVCMOS18, GTL, GTLP, LVDCI_18, LVDCI_DV2_18
1.5 V	HSTL (I, II, III, & IV), LVCMOS15, GTL, GTLP, LVDCI_15, LVDCI_DV2_15, GTLP_DCI, HSTL_DCI (I,II, III & IV)
1.2V	GTL_DCI

The V_{CCO} and the V_{REF} pins for each bank appear in the device pinout tables. Within a given package, the number of V_{REF} and V_{CCO} pins can vary depending on the size of device. In larger devices, more I/O pins convert to V_{REF} pins. Since these are always a superset of the V_{REF} pins used for smaller devices, it is possible to design a PCB that permits migration to a larger device if necessary.

All V_{REF} pins for the largest device anticipated must be connected to the V_{REF} voltage and not used for I/O. In smaller devices, some V_{CCO} pins used in larger devices do not connect within the package. These unconnected pins can be left unconnected externally, or, if necessary, they can be connected to the V_{CCO} voltage to permit migration to a larger device.

Digitally Controlled Impedance (DCI)

Today's chip output signals with fast edge rates require termination to prevent reflections and maintain signal integrity. High pin count packages (especially ball grid arrays) can not accommodate external termination resistors.

Virtex-II DCI provides controlled impedance drivers and on-chip termination for single-ended I/Os. This eliminates the need for external resistors, and improves signal integrity. The DCI feature can be used on any IOB by selecting one of the DCI I/O standards.

When applied to inputs, DCI provides input parallel termination. When applied to outputs, DCI provides controlled impedance drivers (series termination) or output parallel termination.

DCI operates independently on each I/O bank. When a DCI I/O standard is used in a particular I/O bank, external reference resistors must be connected to two dual-function pins

on the bank. These resistors, voltage reference of N transistor (VRN) and the voltage reference of P transistor (VRP) are shown in Figure 9.

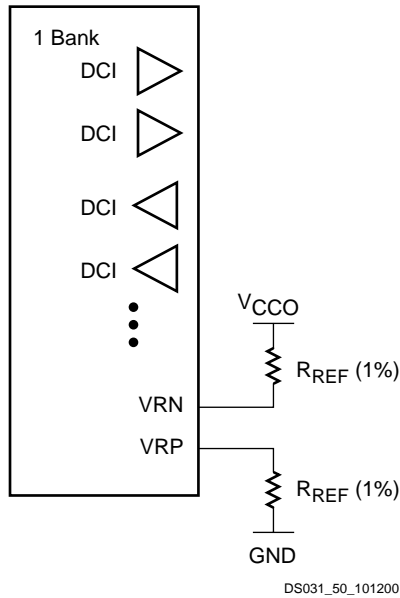

Figure 9: DCI in a Virtex-II Bank

When used with a terminated I/O standard, the value of the resistor is specified by the standard (typically 50 Ω). When used with a controlled impedance driver, the resistor sets the output impedance of the driver within the specified range (25 Ω to 150 Ω). The resistors connected to VRN and VRP do not need to be the same value. 1% resistors are recommended.

The DCI system adjusts the I/O impedance to match the two external reference resistors, or half of the reference resistor, and compensates for impedance changes due to voltage and/or temperature fluctuations. The adjustment is done by turning parallel transistors in the IOB on or off.

Controlled Impedance Drivers (Series Termination)

DCI can be used to provide a buffer with a controlled output impedance. It is desirable for this output impedance to match the transmission line impedance (Z). Virtex-II input buffers also support LVDCI and LVDCI_DV2 I/O standards.

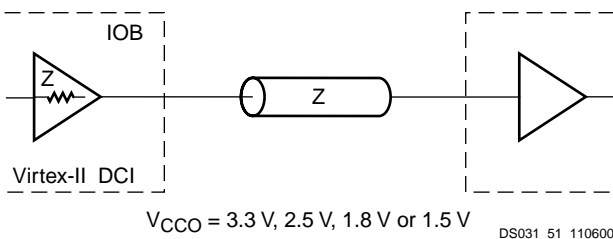

Figure 10: Internal Series Termination

Table 6: SelectI/O Controlled Impedance Buffers

V _{CCO}	DCI	DCI Half Impedance
3.3 V	LVDCI_33	LVDCI_DV2_33
2.5 V	LVDCI_25	LVDCI_DV2_25
1.8 V	LVDCI_18	LVDCI_DV2_18
1.5 V	LVDCI_15	LVDCI_DV2_15

Controlled Impedance Drivers (Parallel Termination)

DCI also provides on-chip termination for SSTL3, SSTL2, HSTL (Class I, II, III, or IV), and GTL/GTLP receivers or transmitters on bidirectional lines.

Table 7 lists the on-chip parallel terminations available in Virtex-II devices. V_{CCO} must be set according to Table 3. Note that there is a V_{CCO} requirement for GTL_DCI and GTLP_DCI, due to the on-chip termination resistor.

Table 7: SelectI/O Buffers With On-Chip Parallel Termination

I/O Standard	External Termination	On-Chip Termination
SSTL3 Class I	SSTL3_I	SSTL3_I_DCI ⁽¹⁾
SSTL3 Class II	SSTL3_II	SSTL3_II_DCI ⁽¹⁾
SSTL2 Class I	SSTL2_I	SSTL2_I_DCI ⁽¹⁾
SSTL2 Class II	SSTL2_II	SSTL2_II_DCI ⁽¹⁾
HSTL Class I	HSTL_I	HSTL_I_DCI
HSTL Class II	HSTL_II	HSTL_II_DCI
HSTL Class III	HSTL_III	HSTL_III_DCI
HSTL Class IV	HSTL_IV	HSTL_IV_DCI
GTL	GTL	GTL_DCI
GTLP	GTLP	GTLP_DCI

Notes:

- 1. SSTL Compatible

For further details, see the *Virtex-II User Guide*.

Figure 11 provides examples illustrating the use of the HSTL_IV_DCI, HSTL_II_DCI, and SSTL2_DCI I/O standards.

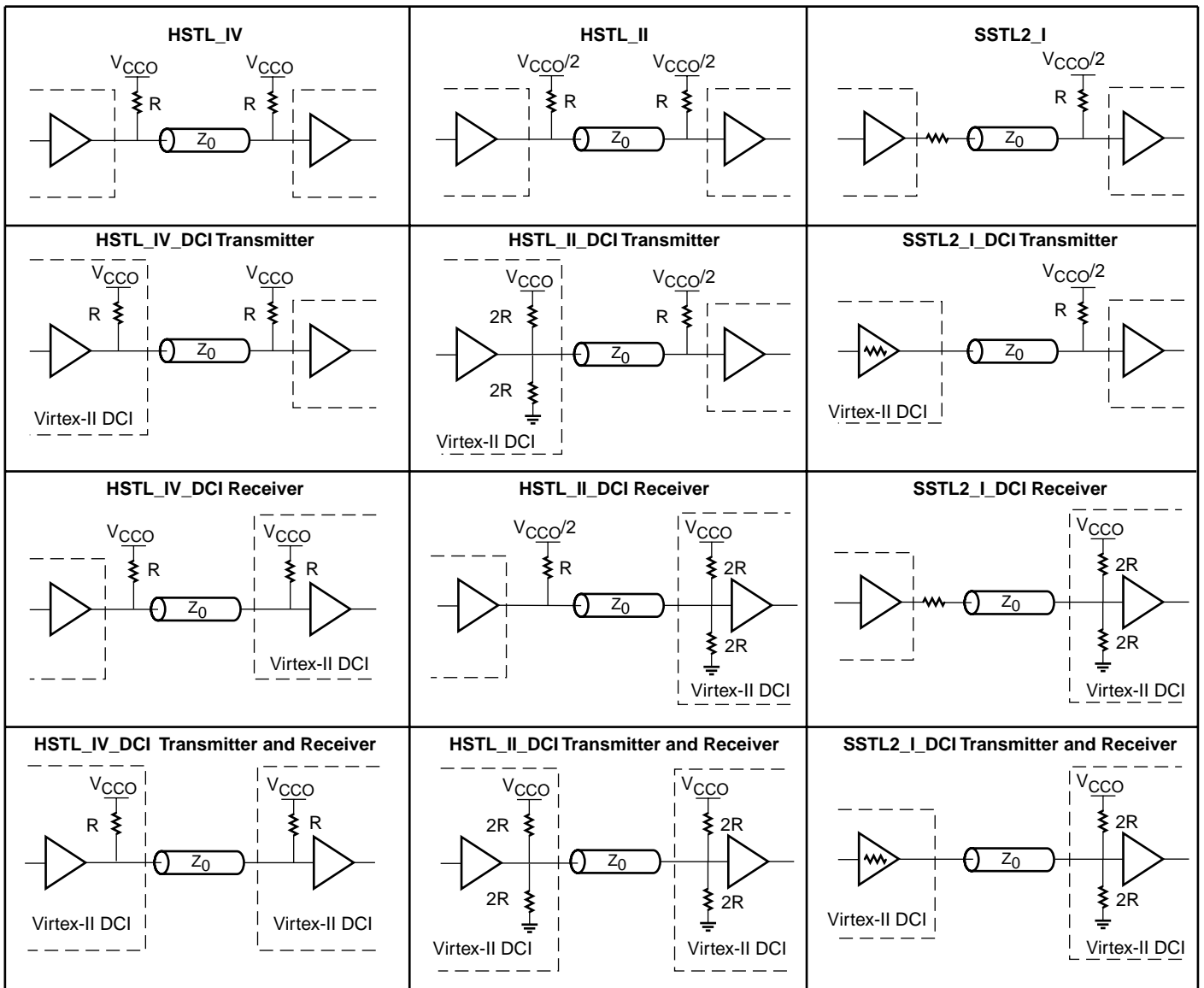

ds031_65_110200

Figure 11: DCI Usage Examples

Configurable Logic Blocks (CLBs)

The Virtex-II configurable logic blocks (CLB) are organized in an array and are used to build combinatorial and synchronous logic designs. Each CLB element is tied to a switch matrix to access the general routing matrix, as shown in Figure 12. A CLB element comprises 4 similar slices, with fast local feedback within the CLB. The four slices are split in two columns of two slices with two independent carry logic chains and one common shift chain.

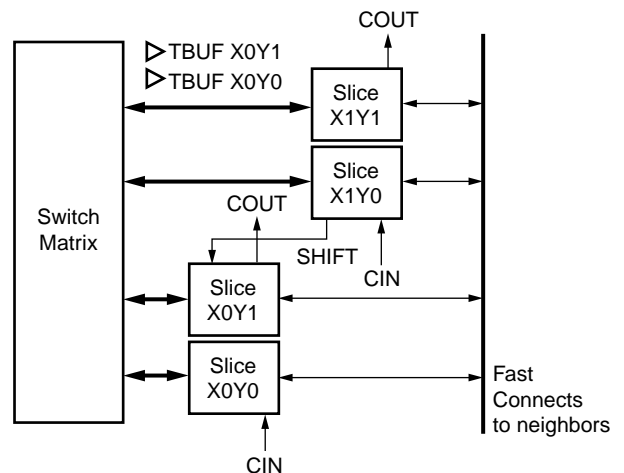

DS031_32_101600

Figure 12: Virtex-II CLB Element

Slice Description

Introduction

Each slice includes two 4-input function generators, carry logic, arithmetic logic gates, wide function multiplexers and two storage elements. As shown in Figure 13, each 4-input function generator is programmable as a 4-input LUT, 16 bits of distributed SelectRAM memory, or a 16-bit variable-tap shift register element.

The output from the function generator in each slice drives both the slice output and the D input of the storage element. Figure 14 shows a more detailed view of a single slice.

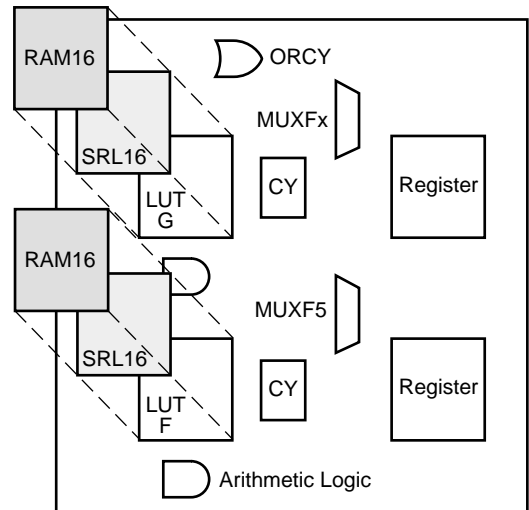

DS031_31_100900

Figure 13: Virtex-II Slice Configuration

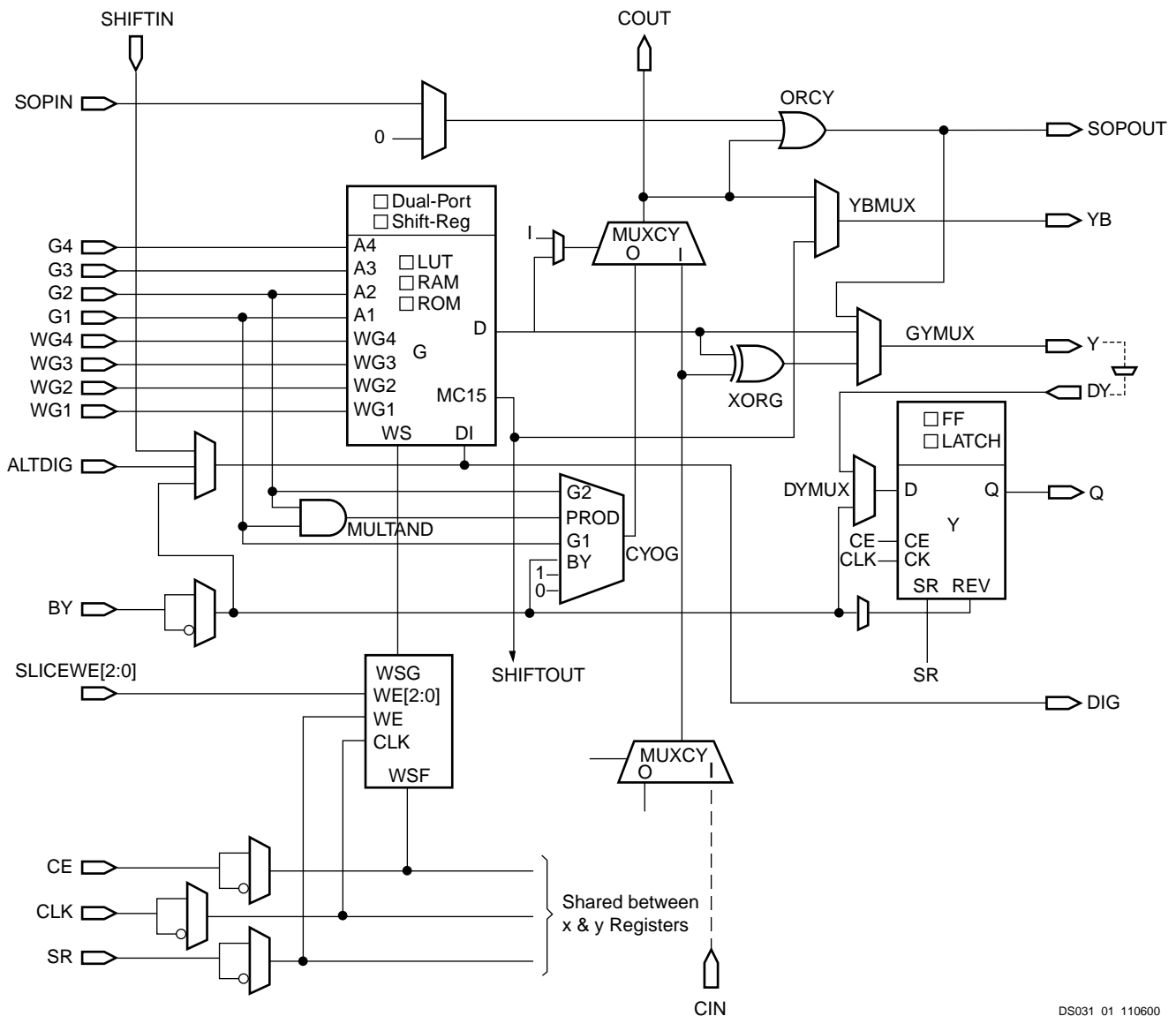

DS031_01_110600

Figure 14: Virtex-II Slice (Top Half)

Configurations

Look-Up Table

Virtex-II function generators are implemented as 4-input look-up tables (LUTs). Four independent inputs are provided to each of the two function generators in a slice (F and G). These function generators are each capable of implementing any arbitrarily defined boolean function of four inputs. The propagation delay is therefore independent of the function implemented. Signals from the function generators can exit the slice (X or Y output), can input the XOR dedicated gate (see arithmetic logic), or input the carry-logic multiplexer (see fast look-ahead carry logic), or feed the D input of the storage element, or go to the MUXF5 (not shown in Figure 14).

In addition to the basic LUTs, the Virtex-II slice contains logic (MUXF5 and MUXFX multiplexers) that combines function generators to provide any function of five, six, seven, or eight inputs. The MUXFX are either MUXF6, MUXF7 or MUXF8 according to the slice considered in the CLB. Selected functions up to nine inputs (MUXF5 multiplexer) can be implemented in one slice. The MUXFX can also be a MUXF6, MUXF7, or MUXF8 multiplexers to map any functions of six, seven, or eight inputs and selected wide logic functions.

Register/Latch

The storage elements in a Virtex-II slice can be configured either as edge-triggered D-type flip-flops or as level-sensitive latches. The D input can be directly driven by the X or Y output via the DX or DY input, or by the slice inputs bypassing the function generators via the BX or BY input. The clock enable signal (CE) is active High by default. If left unconnected, the clock enable for that storage element defaults to the active state.

In addition to clock (CK) and clock enable (CE) signals, each slice has set and reset signals (SR and BY slice inputs). SR forces the storage element into the state specified by the attribute SRHIGH or SRLOW. SRHIGH forces a logic "1" when SR is asserted. SRLOW forces a logic "0". When SR is used, a second input (BY) forces the storage element into the opposite state. The reset condition is predominant over the set condition. (See Figure 15.)

The initial state after configuration or global initial state is defined by a separate INIT0 and INIT1 attribute. By default, setting the SRLOW attribute sets INIT0, and setting the SRHIGH attribute sets INIT1.

For each slice, set and reset can be set to be synchronous or asynchronous. Virtex-II devices also have the ability to set INIT0 and INIT1 independent of SRHIGH and SRLOW.

The control signals clock (CLK), clock enable (CE) and set/reset (SR) are common to both storage elements in one slice. All of the control signals have independent polarity. Any inverter placed on a control input is automatically absorbed.

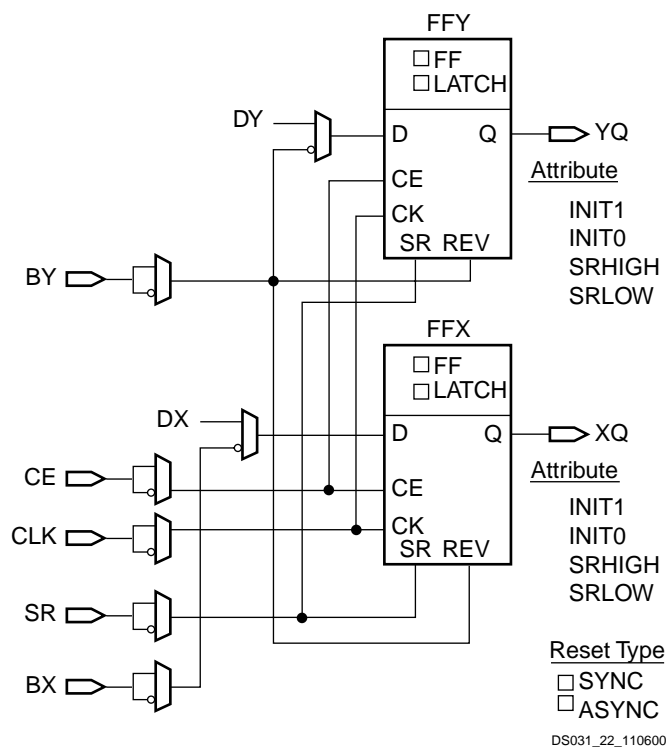

Figure 15: Register / Latch Configuration in a Slice

The set and reset functionality of a register or a latch can be configured as follows:

- No set or reset
- Synchronous set
- Synchronous reset
- Synchronous set and reset
- Asynchronous set (preset)
- Asynchronous reset (clear)
- Asynchronous set and reset (preset and clear)

The synchronous reset has precedence over a set, and an asynchronous clear has precedence over a preset.

Distributed SelectRAM Memory

Each function generator (LUT) can implement a 16 x 1-bit synchronous RAM resource called a distributed SelectRAM element. The SelectRAM elements are configurable within a CLB to implement the following:

- Single-Port 16 x 8 bit RAM
- Single-Port 32 x 4 bit RAM
- Single-Port 64 x 2 bit RAM
- Single-Port 128 x 1 bit RAM
- Dual-Port 16 x 4 bit RAM
- Dual-Port 32 x 2 bit RAM
- Dual-Port 64 x 1 bit RAM

Distributed SelectRAM memory modules are synchronous (write) resources. The combinatorial read access time is extremely fast, while the synchronous write simplifies

high-speed designs. A synchronous read can be implemented with a storage element in the same slice. The distributed SelectRAM memory and the storage element share the same clock input. A Write Enable (WE) input is active High, and is driven by the SR input.

Table 8 shows the number of LUTs (2 per slice) occupied by each distributed SelectRAM configuration.

Table 8: Distributed SelectRAM Configurations

RAM	Number of LUTs
16 x 1S	1
16 x 1D	2
32 x 1S	2
32 x 1D	4
64 x 1S	4
64 x 1D	8
128 x 1S	8

Notes:

1. S = single-port configuration; D = dual-port configuration

For single-port configurations, distributed SelectRAM memory has one address port for synchronous writes and asynchronous reads.

For dual-port configurations, distributed SelectRAM memory has one port for synchronous writes and asynchronous reads and another port for asynchronous reads. The func-

tion generator (LUT) has separated read address inputs (A1, A2, A3, A4) and write address inputs (WG1/WF1, WG2/WF2, WG3/WF3, WG4/WF4).

In single-port mode, read and write addresses share the same address bus. In dual-port mode, one function generator (R/W port) is connected with shared read and write addresses. The second function generator has the A inputs (read) connected to the second read-only port address and the W inputs (write) shared with the first read/write port address.

Figure 16, Figure 17, and Figure 18 illustrate various example configurations.

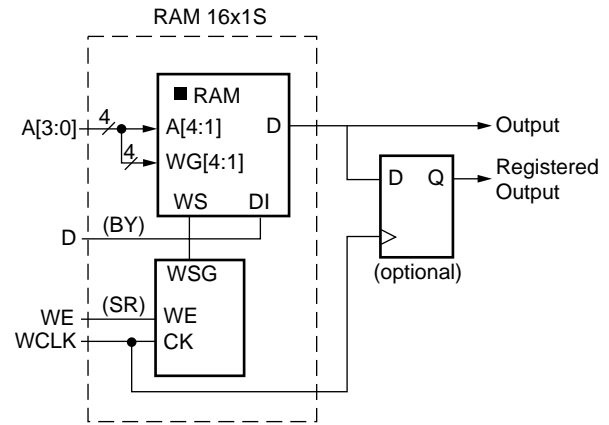

DS031_02_100900

Figure 16: Distributed SelectRAM (RAM16x1S)

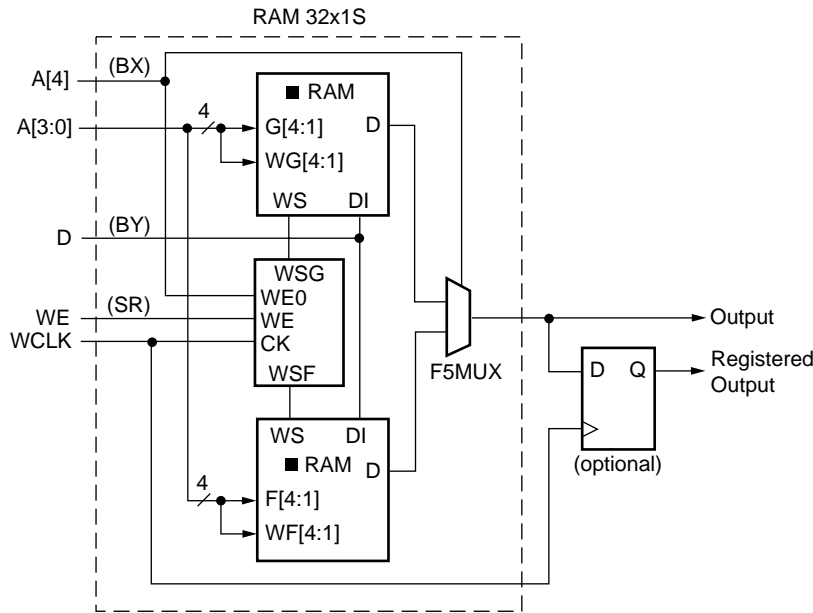

DS031_03_110100

Figure 17: Single-Port Distributed SelectRAM (RAM32x1S)

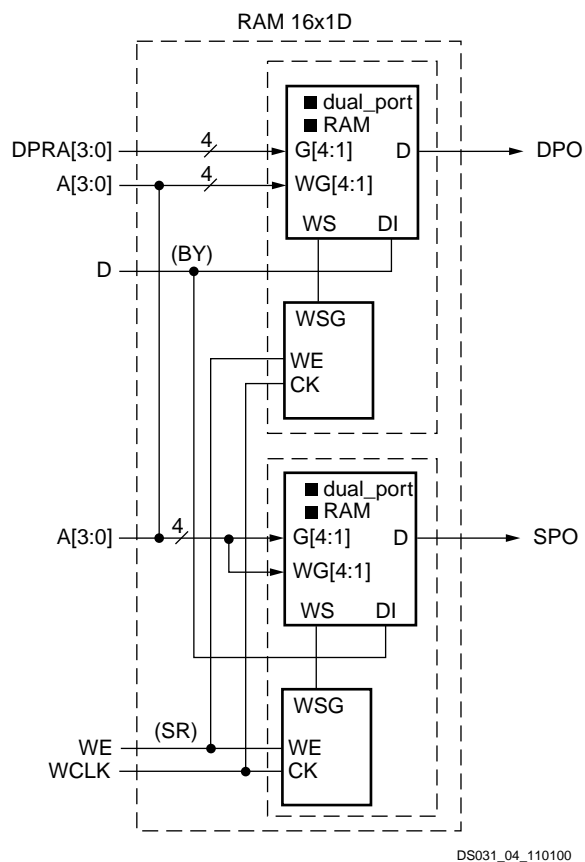

Figure 18: Dual-Port Distributed SelectRAM (RAM16x1D)

Similar to the RAM configuration, each function generator (LUT) can implement a 16 x 1-bit ROM. Five configurations are available: ROM16x1, ROM32x1, ROM64x1, ROM128x1, and ROM256x1. The ROM elements are cascadable to implement wider or/and deeper ROM. ROM contents are loaded at configuration. Table 9 shows the number of LUTs occupied by each configuration.

Table 9: ROM Configuration

ROM	Number of LUTs
16 x 1	1
32 x 1	2
64 x 1	4
128 x 1	8 (1 CLB)
256 x 1	16 (2 CLBs)

Shift Registers

Each function generator can also be configured as a 16-bit shift register. The write operation is synchronous with a clock input (CLK) and an optional clock enable, as shown in Figure 19. A dynamic read access is performed through the 4-bit address bus, A[3:0]. The configurable 16-bit shift register cannot be set or reset. The read is asynchronous, however the storage element or flip-flop is available to implement a synchronous read. The storage element should always be used with a constant address. For example, when building an 8-bit shift register and configuring the addresses to point to the 7th bit, the 8th bit can be the flip-flop. The overall system performance is improved by using the superior clock-to-out of the flip-flops.

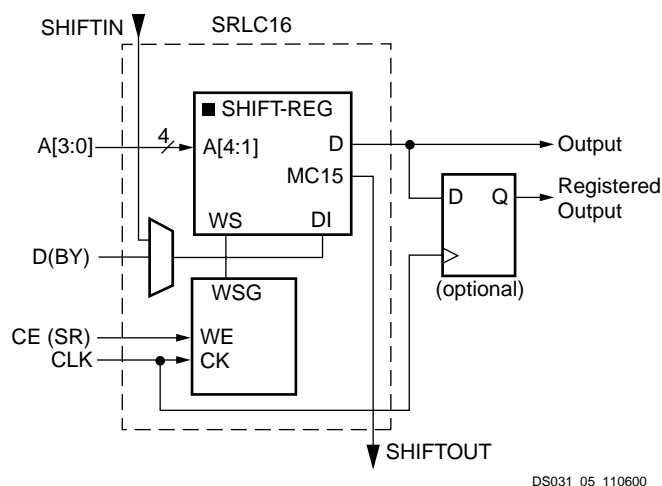
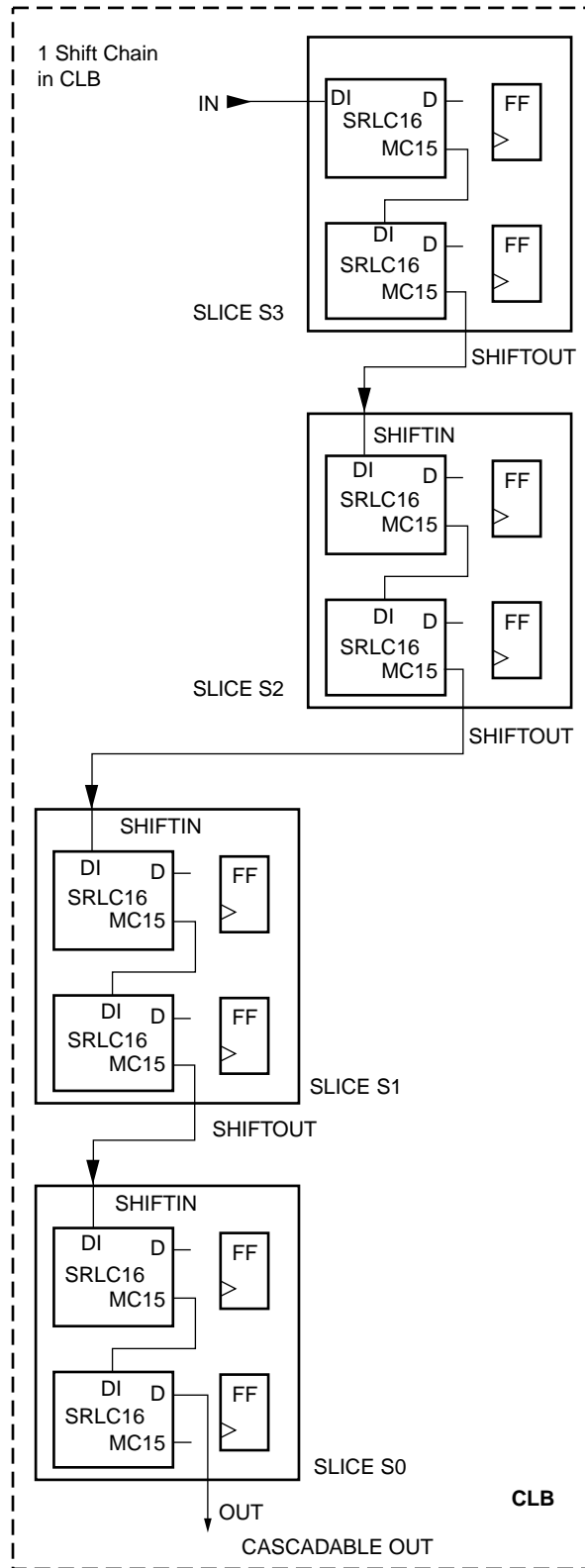

Figure 19: Shift Register Configurations

An additional dedicated connection between shift registers allows connecting the last bit of one shift register to the first bit of the next, without using the ordinary LUT output. (See Figure 20.) Longer shift registers can be built with dynamic access to any bit in the chain. The shift register chaining and the MUXF5, MUXF6, and MUXF7 multiplexers allow up to a 128-bit shift register with addressable access to be implemented in one CLB.



DS031_06_110200

Figure 20: Cascadable Shift Register

Multiplexers

Virtex-II function generators and associated multiplexers can implement the following:

- 4:1 multiplexer in one slice
- 8:1 multiplexer in two slices
- 16:1 multiplexer in one CLB element (4 slices)
- 32:1 multiplexer in two CLB elements (8 slices)

Each Virtex-II slice has one MUXF5 multiplexer and one MUXFX multiplexer. The MUXFX multiplexer implements the MUXF6, MUXF7, or MUXF8, as shown in [Figure 21](#). Each CLB element has two MUXF6 multiplexers, one MUXF7 multiplexer and one MUXF8 multiplexer. Examples of multiplexers are shown in the *Virtex-II User Guide*. Any LUT can implement a 2:1 multiplexer.

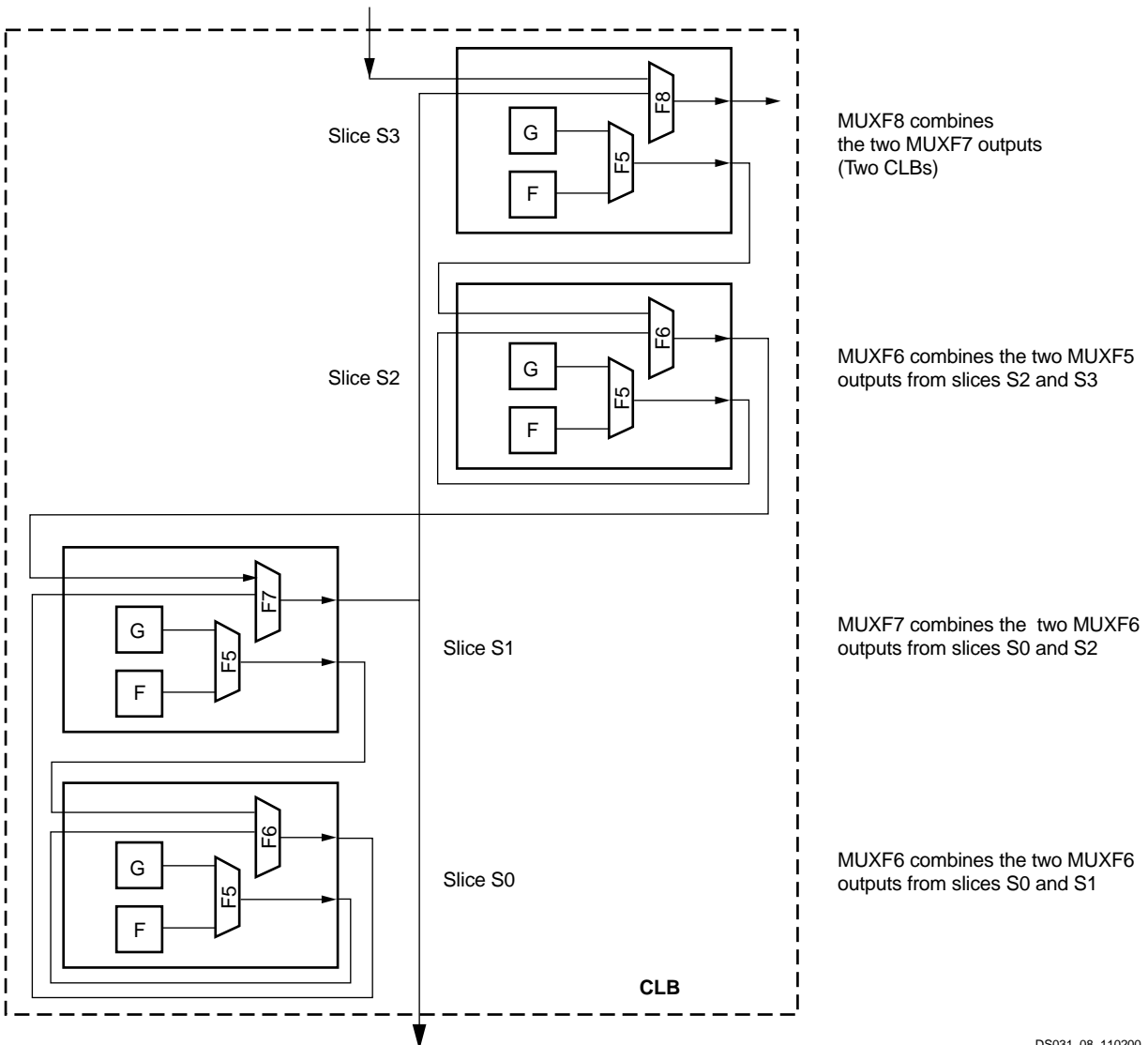

Figure 21: MUXF5 and MUXFX multiplexers

DS031_08_110200

Fast Lookahead Carry Logic

Dedicated carry logic provides fast arithmetic addition and subtraction. The Virtex-II CLB has two separate carry chains, as shown in the [Figure 22](#).

The height of the carry chains is two bits per slice. The carry chain in the Virtex-II device is running upward. The dedicated carry path and carry multiplexer (MUXCY) can also be used to cascade function generators for implementing wide logic functions.

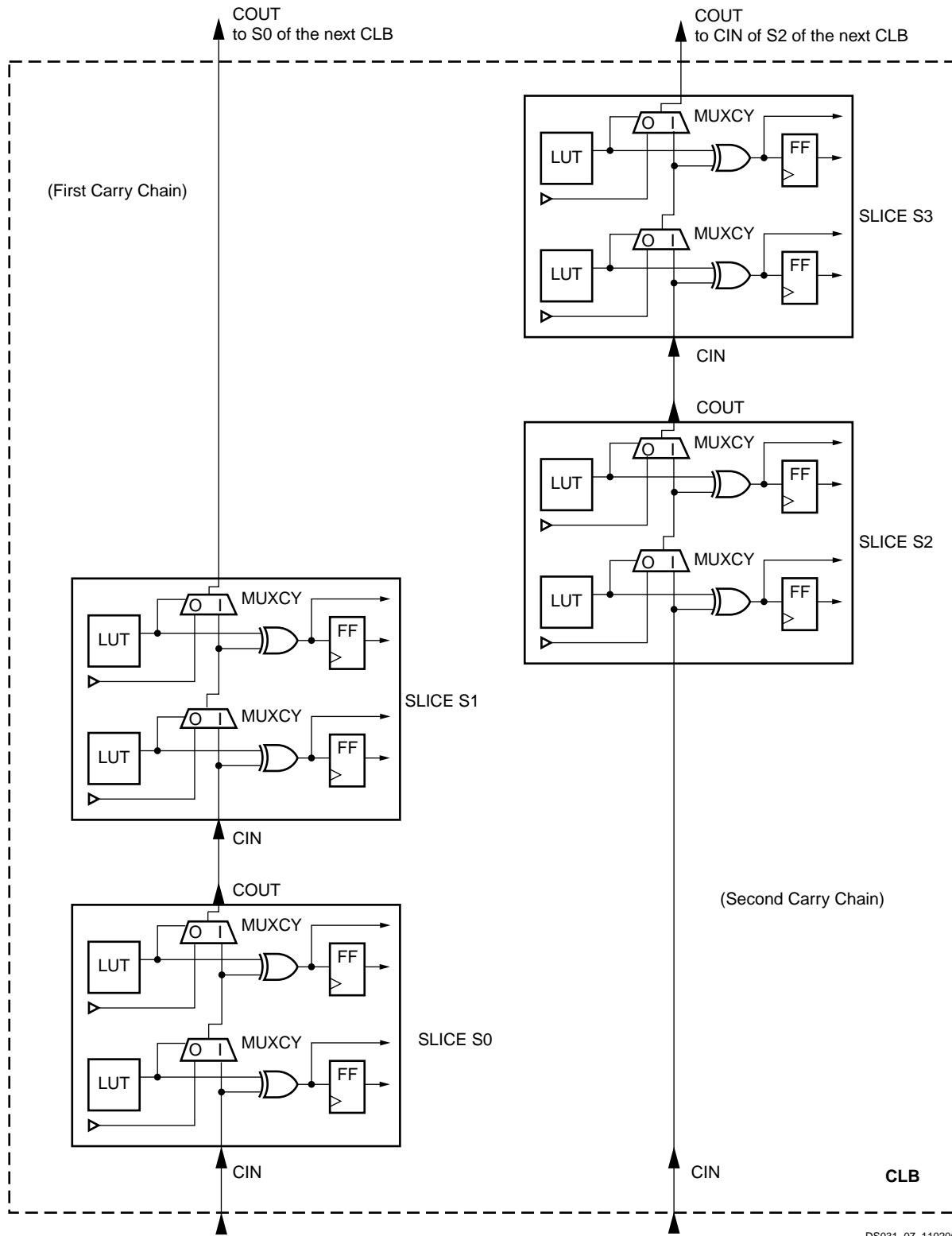

DS031_07_110200

Figure 22: Fast Carry Logic Path

Arithmetic Logic

The arithmetic logic includes an XOR gate that allows a 2-bit full adder to be implemented within a slice. In addition,

a dedicated AND (MULT_AND) gate (shown in Figure 14) improves the efficiency of multiplier implementation.

Sum of Products

Each Virtex-II slice has a dedicated OR gate named ORCY, ORing together outputs from the slices carryout and the ORCY from an adjacent slice. The ORCY gate with the dedicated Sum of Products (SOP) chain are designed for implementing

large, flexible SOP chains. One input of each ORCY is connected through the fast SOP chain to the output of the previous ORCY in the same slice row. The second input is connected to the output of the top MUXCY in the same slice, as shown in Figure 23.

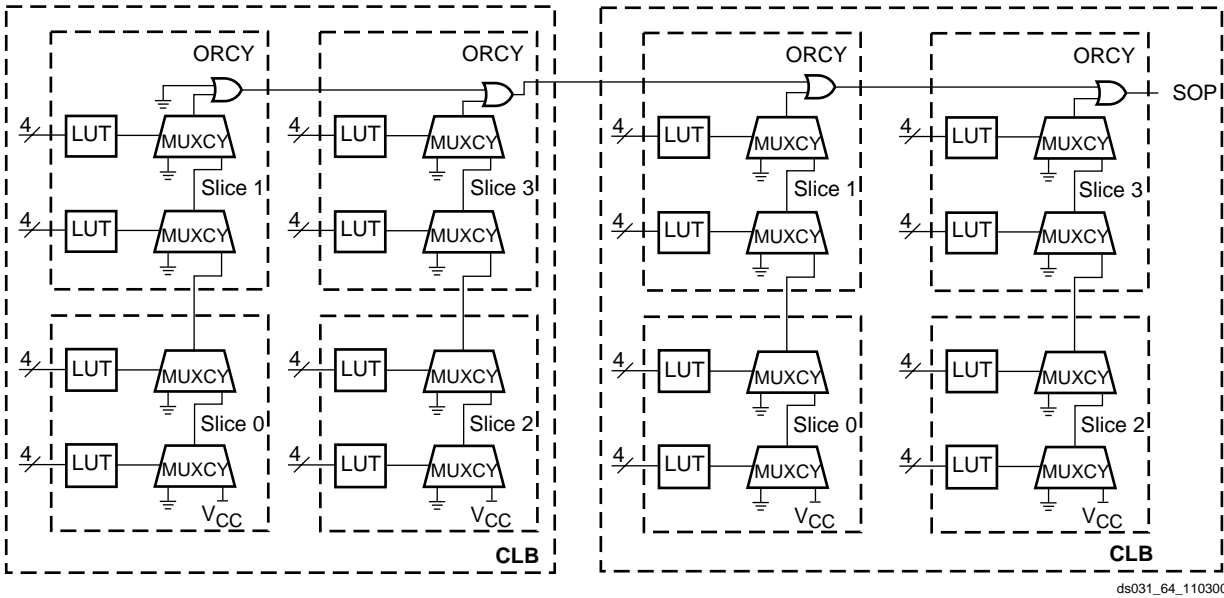

Figure 23: Horizontal Cascade Chain

LUTs and MUXCYs can implement large AND gates or other combinational logic functions. Figure 24 illustrates

LUT and MUXCY resources configured as a 16-input AND gate.

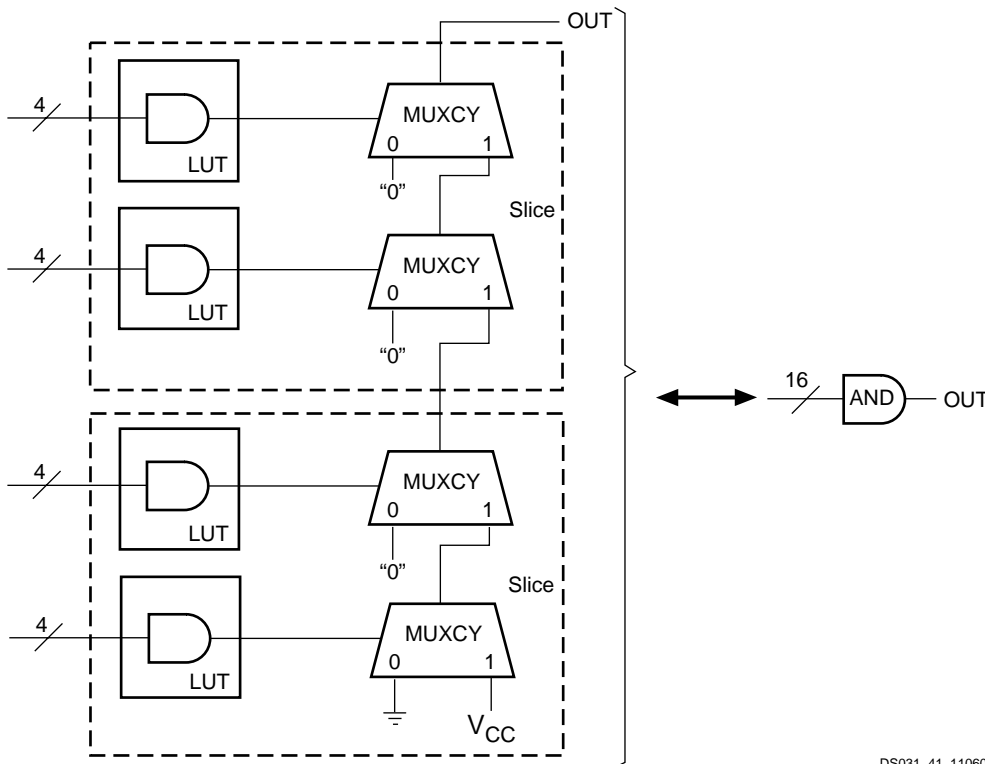

Figure 24: Wide-Input AND Gate (12 Inputs)

3-State Buffers

Introduction

Each Virtex-II CLB contains two 3-state drivers (TBUFs) that can drive on-chip busses. Each 3-state buffer has its own 3-state control pin and its own input pin.

Each of the four slices have access to the two 3-state buffers through the switch matrix, as shown in Figure 25. TBUFs in neighboring CLBs can access slice outputs by direct connects. The outputs of the 3-state buffers drive horizontal routing resources used to implement 3-state busses.

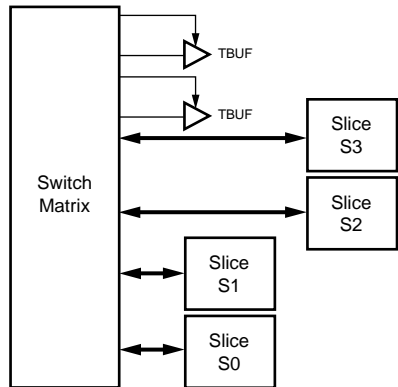

DS031_37_060700

Figure 25: Virtex-II 3-State Buffers

The 3-state buffer logic is implemented using AND-OR logic rather than 3-state drivers, so that timing is more predictable and less load dependant especially with larger devices.

Locations / Organization

Four horizontal routing resources per CLB are provided for on-chip 3-state busses. Each 3-state buffer has access alternately to two horizontal lines, which can be partitioned as shown in Figure 26. The switch matrices corresponding to SelectRAM memory and multiplier or I/O blocks are skipped.

Number of 3-State Buffers

Table 10 shows the number of 3-state buffers available in each Virtex-II device. The number of 3-state buffers is twice the number of CLB elements.

Table 10: Virtex-II 3-State Buffers

Device	3-State Buffers per Row	Total Number of 3-State Buffers
XC2V40	16	128
XC2V80	16	256
XC2V250	32	768
XC2V500	48	1,536
XC2V1000	64	2,560
XC2V1500	80	3,840
XC2V2000	96	5,376
XC2V3000	112	7,168
XC2V4000	144	11,520
XC2V6000	176	16,896
XC2V8000	208	23,296
XC2V10000	240	30,720

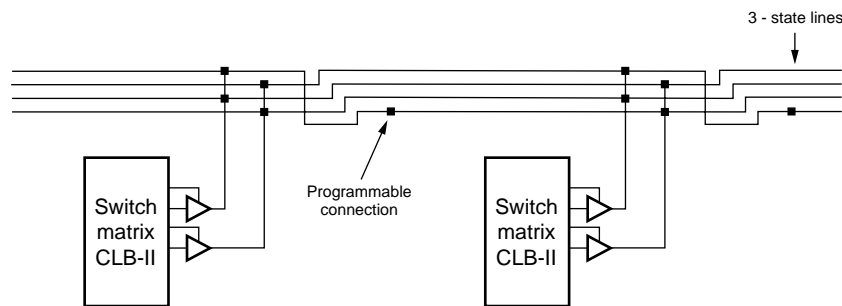

DS031_09_032700

Figure 26: 3-State Buffer Connection to Horizontal Lines

CLB/Slice Configurations

Table 11 summarizes the logic resources in one CLB. All of the CLBs are identical and each CLB or slice can be implemented in one of the configurations listed. **Table 12** shows the available resources in all CLBs.

Table 11: Logic Resources in One CLB

Slices	LUTs	Flip-Flops	MULT_ANDs	Arithmetic & Carry-Chains	SOP Chains	Distributed SelectRAM	Shift Registers	TBUF
4	8	8	8	2	2	128 bits	128 bits	2

Table 12: Virtex-II Logic Resources Available in All CLBs

Device	CLB Array: Row x Column	Number of Slices	Number of LUTs	Max Distributed SelectRAM or Shift Register (bits)	Number of Flip-Flops	Number of Carry-Chains ⁽¹⁾	Number of SOP Chains ⁽¹⁾
XC2V40	8 x 8	256	516	8,192	516	16	16
XC2V80	16 x 8	512	1,024	16,384	1,024	16	32
XC2V250	24 x 16	1,536	3,072	49,152	3,072	32	48
XC2V500	32 x 24	3,072	6,144	98,304	6,144	48	64
XC2V1000	40 x 32	5,120	10,240	163,840	10,240	64	80
XC2V1500	48 x 40	7,680	15,360	245,760	15,360	80	96
XC2V2000	56 x 48	10,752	21,504	344,064	21,504	96	112
XC2V3000	64 x 56	14,336	28,672	458,752	28,672	112	128
XC2V4000	80 x 72	23,040	46,080	737,280	46,080	144	160
XC2V6000	96 x 88	33,792	67,584	1,081,344	67,584	176	192
XC2V8000	112 x 104	46,592	93,184	1,490,944	93,184	208	224
XC2V10000	128 x 120	61,440	122,880	1,966,080	122,880	240	256

Notes:

1. The carry-chains and SOP chains can be split or cascaded.

18-Kbit Block SelectRAM Resources

Introduction

Virtex-II devices incorporate large amounts of 18-Kbit block SelectRAM. These complement the distributed SelectRAM resources that provide shallow RAM structures implemented in CLBs. Each Virtex-II block SelectRAM is an 18-Kbit true dual-port RAM with two independently clocked and independently controlled synchronous ports that access a common storage area. Both ports are functionally identical.

Each port has the following types of inputs: Clock and Clock Enable, Write Enable, Set/Reset, and Address, as well as separate Data/parity data inputs (for write) and Data/parity data outputs (for read).

Operation is synchronous; the block SelectRAM behaves like a register. Control, address and data inputs must (and need only) be valid during the set-up time window prior to a

rising (or falling, a configuration option) clock edge. Data outputs change as a result of the same clock edge.

Configuration

The Virtex-II block SelectRAM supports various configurations, including single- and dual-port RAM and various data/address aspect ratios. Supported memory configurations for single- and dual-port modes are shown in **Table 13**.

Table 13: Dual- and Single-Port Configurations

16K x 1 bit	2K x 9 bits
8K x 2 bits	1K x 18 bits
4K x 4 bits	512 x 36 bits

Single-Port Configuration

As a single-port RAM, the block SelectRAM has access to the 18-Kbit memory locations in any of the 2K x 9-bit,

1K x 18-bit, or 512 x 36-bit configurations and to 16-Kbit memory locations in any of the 16K x 1-bit, 8K x 2-bit, or 4K x 4-bit configurations. The advantage of the 9-bit, 18-bit and 36-bit widths is the ability to store a parity bit for each eight bits. Parity bits must be generated or checked externally in user logic. In such cases, the width is viewed as 8 + 1, 16 + 2, or 32 + 4. These extra parity bits are stored and behave exactly as the other bits, including the timing parameters. Video applications can use the 9-bit ratio of Virtex-II block SelectRAM memory to advantage.

Each block SelectRAM cell is a fully synchronous memory as illustrated in Figure 27. Input data bus and output data bus widths are identical.

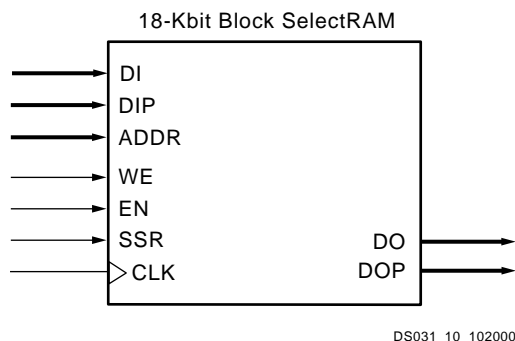

DS031_10_102000

Figure 27: 18-Kbit Block SelectRAM Memory in Single-Port Mode

Table 14: Dual-Port Mode Configurations

Port A	16K x 1	16K x 1	16K x 1	16K x 1	16K x 1	16K x 1
Port B	16K x 1	8K x 2	4K x 4	2K x 9	1K x 18	512 x 36
Port A	8K x 2	8K x 2	8K x 2	8K x 2	8K x 2	
Port B	8K x 2	4K x 4	2K x 9	1K x 18	512 x 36	
Port A	4K x 4	4K x 4	4K x 4	4K x 4		
Port B	4K x 4	2K x 9	1K x 18	512 x 36		
Port A	2K x 9	2K x 9	2K x 9			
Port B	2K x 9	1K x 18	512 x 36			
Port A	1K x 18	1K x 18				
Port B	1K x 18	512 x 36				
Port A	512 x 36					
Port B	512 x 36					

If both ports are configured in either 2K x 9-bit, 1K x 18-bit, or 512 x 36-bit configurations, the 18-Kbit block is accessible from port A or B. If both ports are configured in either 16K x 1-bit, 8K x 2-bit, or 4K x 4-bit configurations, the

Dual-Port Configuration

As a dual-port RAM, each port of block SelectRAM has access to a common 18-Kbit memory resource. These are fully synchronous ports with independent control signals for each port. The data widths of the two ports can be configured independently, providing built-in bus-width conversion.

Table 14 illustrates the different configurations available on ports A & B.

16 K-bit block is accessible from Port A or Port B. All other configurations result in one port having access to an 18-Kbit memory block and the other port having access to a 16 K-bit subset of the memory block equal to 16 Kbits.

Each block SelectRAM cell is a fully synchronous memory, as illustrated in **Figure 28**. The two ports have independent inputs and outputs and are independently clocked.

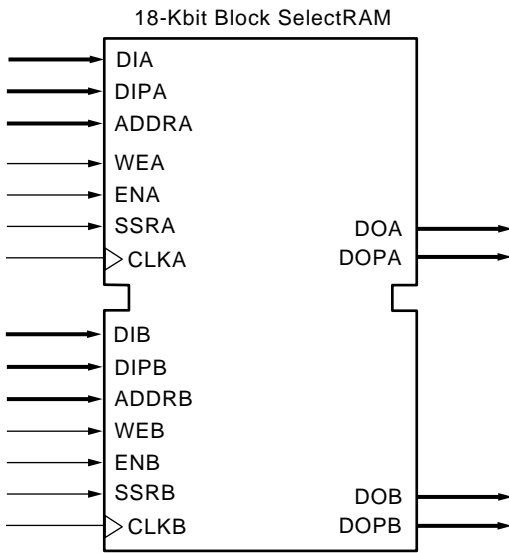

Figure 28: 18-Kbit Block SelectRAM in Dual-Port Mode

Port Aspect Ratios

Table 15 shows the depth and the width aspect ratios for the 18-Kbit block SelectRAM. Virtex-II block SelectRAM also includes dedicated routing resources to provide an efficient interface with CLBs, block SelectRAM, and multipliers.

Table 15: 18-Kbit Block SelectRAM Port Aspect Ratio

Width	Depth	Address Bus	Data Bus	Parity Bus
1	16,384	ADDR[13:0]	DATA[0]	N/A
2	8,192	ADDR[12:0]	DATA[1:0]	N/A
4	4,096	ADDR[11:0]	DATA[3:0]	N/A
9	2,048	ADDR[10:0]	DATA[7:0]	Parity[0]
18	1,024	ADDR[9:0]	DATA[15:0]	Parity[1:0]
36	512	ADDR[8:0]	DATA[31:0]	Parity[3:0]

Read/Write Operations

The Virtex-II block SelectRAM read operation is fully synchronous. An address is presented, and the read operation is enabled by control signal ENA or ENB. Then, depending on clock polarity, a rising or falling clock edge causes the stored data to be loaded into output registers.

The write operation is also fully synchronous. Data and address are presented, and the write operation is enabled by control signals WEA or WEB in addition to ENA or ENB. Then, again depending on the clock input mode, a rising or falling clock edge causes the data to be loaded into the memory cell addressed.

A write operation performs a simultaneous read operation. There are three different options available, each set by configuration:

1. "WRITE_FIRST"

The "WRITE_FIRST" option is a transparent mode. The same clock edge that writes the data input (DI) into the memory also transfers DI into the output registers DO as shown in **Figure 29**.

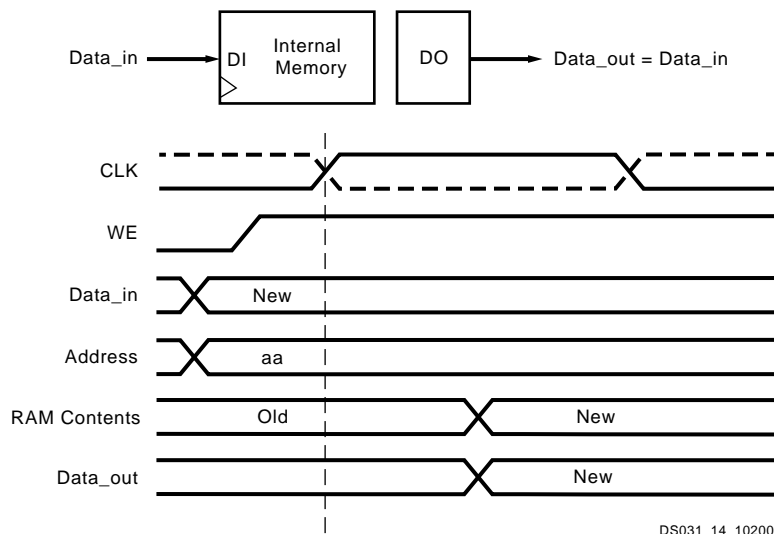

Figure 29: WRITE_FIRST Mode

2. "READ_FIRST"

The "READ_FIRST" option is a read-before-write mode.

The same clock edge that writes data input (DI) into the memory also transfers the prior content of the memory cell addressed into the data output registers DO, as shown in Figure 30.

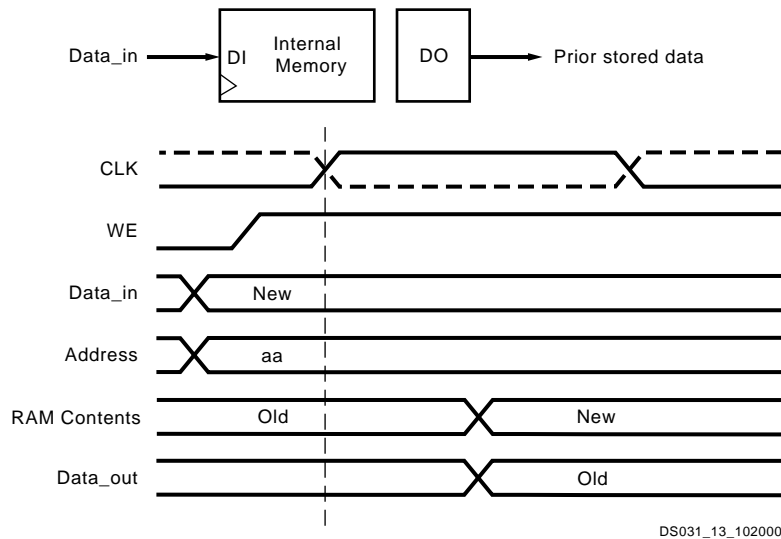

Figure 30: READ_FIRST Mode

3. "NO_CHANGE"

The "NO_CHANGE" option maintains the content of the output registers, regardless of the write operation. The clock edge during the write mode has no effect on the content of the data output register DO. When the port is configured as "NO_CHANGE", only a read operation loads a new value in the output register DO, as shown in Figure 31.

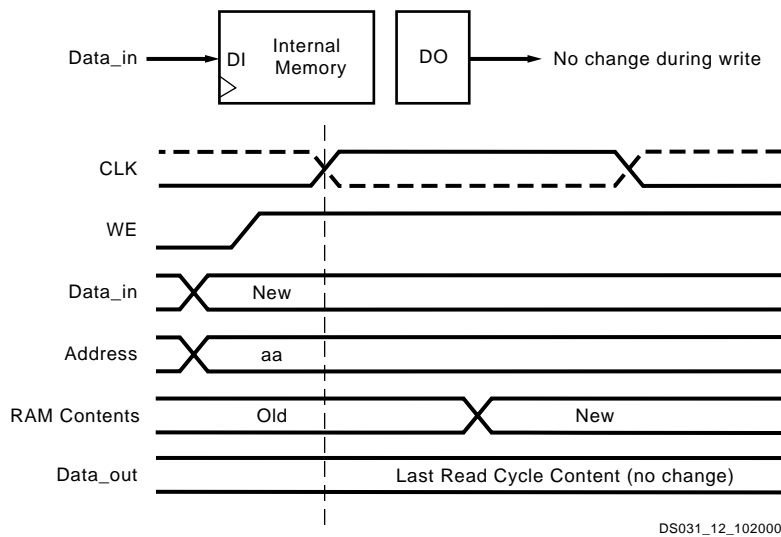

Figure 31: NO_CHANGE Mode

Control Pins and Attributes

Virtex-II SelectRAM memory has two independent ports with the control signals described in Table 16. All control inputs including the clock have an optional inversion.

Table 16: Control Functions

Control Signal	Function
CLK	Read and Write Clock
EN	Enable affects Read, Write, Set, Reset
WE	Write Enable
SSR	Set DO register to SRVAL (attribute)

Initial memory content is determined by the INIT_xx attributes. Separate attributes determine the output register value after device configuration (INIT) and SSR is asserted (SRVAL). Both attributes (INIT_B and SRVAL) are available for each port when a block SelectRAM resource is configured as dual-port RAM.

Locations

Virtex-II SelectRAM memory blocks are organized in either four or six columns. The number of blocks per column depends of the device array size and is equivalent to the

number of CLBs in a column divided by four. Column locations are shown in Table 17.

Table 17: SelectRAM Memory Floor Plan

Device	Columns	SelectRAM Blocks	
		Per Column	Total
XC2V40	2	2	4
XC2V80	2	4	8
XC2V250	4	6	24
XC2V500	4	8	32
XC2V1000	4	10	40
XC2V1500	4	12	48
XC2V2000	4	14	56
XC2V3000	6	16	96
XC2V4000	6	20	120
XC2V6000	6	24	144
XC2V8000	6	28	168
XC2V10000	6	32	192

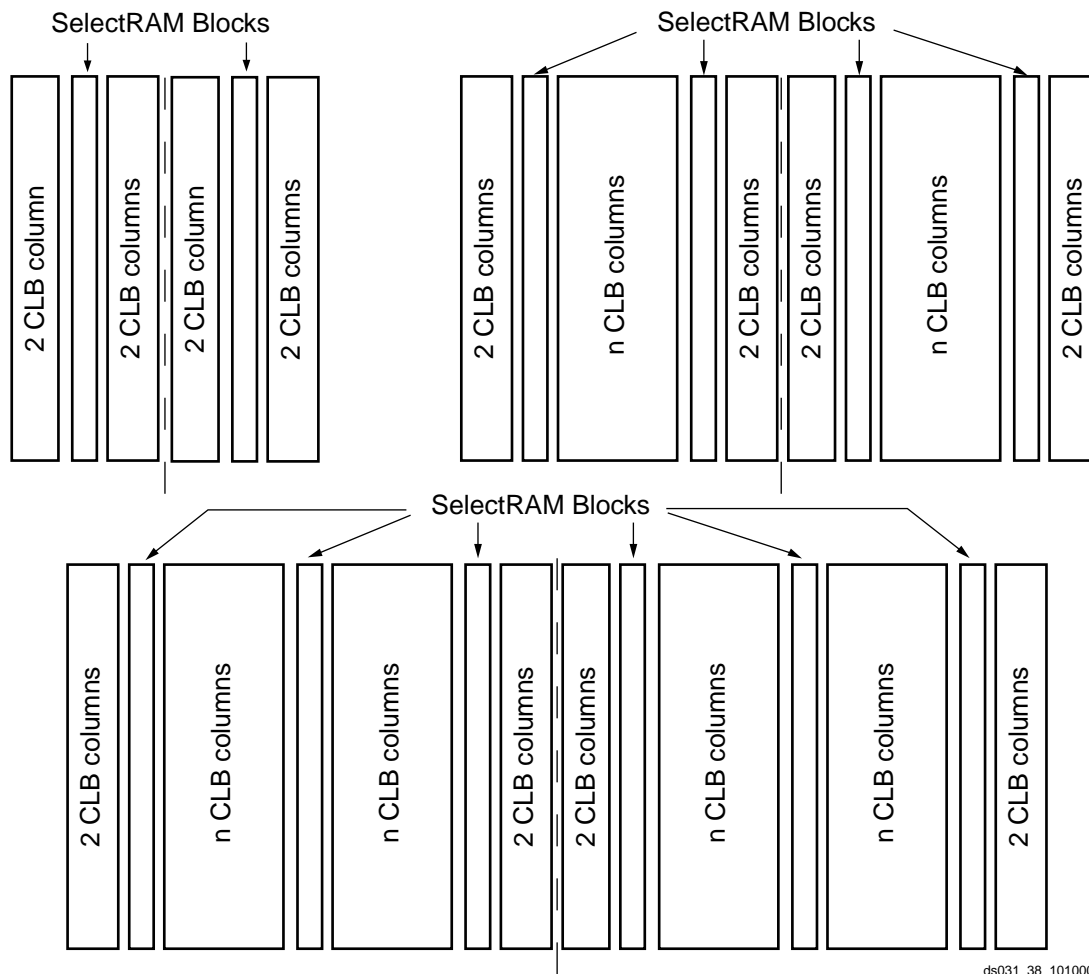

Figure 32: Block SelectRAM (2-column, 4-column, and 6-column)

Total Amount of SelectRAM Memory

Table 18 shows the amount of block SelectRAM memory available for each Virtex-II device. The 18-Kbit SelectRAM blocks are cascadable to implement deeper or wider single- or dual-port memory resources.

Table 18: Virtex-II SelectRAM Memory Available

Device	Total SelectRAM Memory		
	Blocks	in Kbits	in Bits
XC2V40	4	72	73,728
XC2V80	8	144	147,456
XC2V250	24	432	442,368
XC2V500	32	576	589,824
XC2V1000	40	720	737,280
XC2V1500	48	864	884,736
XC2V2000	56	1,008	1,032,192
XC2V3000	96	1,728	1,769,472
XC2V4000	120	2,160	2,211,840
XC2V6000	144	2,592	2,654,208
XC2V8000	168	3,024	3,096,576
XC2V10000	192	3,456	3,538,944

18-Bit x 18-Bit Multipliers

Introduction

A Virtex-II multiplier block is an 18-bit by 18-bit 2's complement signed multiplier. Virtex-II devices incorporate many embedded multiplier blocks. These multipliers can be associated with an 18-Kbit block SelectRAM resource or can be used independently. They are optimized for high-speed operations and have a lower power consumption compared to an 18-bit x 18-bit multiplier in slices.

Each SelectRAM memory and multiplier block is tied to four switch matrices, as shown in Figure 33.

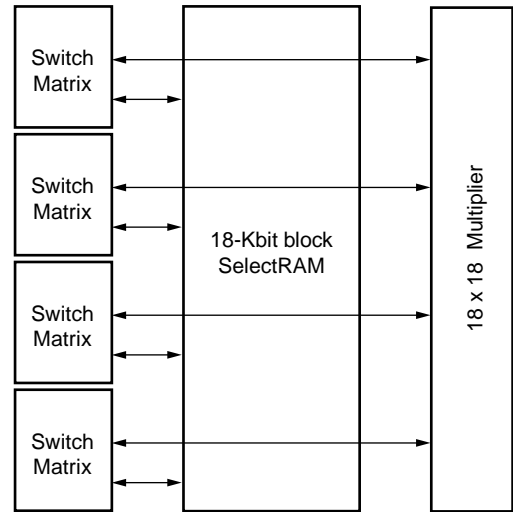

DS031_33_101000

Figure 33: SelectRAM and Multiplier Blocks

Association With Block SelectRAM Memory

The interconnect is designed to allow SelectRAM memory and multiplier blocks to be used at the same time, but some interconnect is shared between the SelectRAM and the multiplier. Thus, SelectRAM memory can be used only up to 18 bits wide when the multiplier is used, because the multiplier shares inputs with the upper data bits of the SelectRAM memory.

This sharing of the interconnect is optimized for an 18-bit-wide block SelectRAM resource feeding the multiplier. The use of SelectRAM memory and the multiplier with an accumulator in LUTs allows for implementation of a digital signal processor (DSP) multiplier-accumulator (MAC) function, which is commonly used in finite and infinite impulse response (FIR and IIR) digital filters.

Configuration

The multiplier block is an 18-bit by 18-bit signed multiplier (2's complement). Both A and B are 18-bit-wide inputs, and the output is 36 bits. Figure 34 shows a multiplier block.

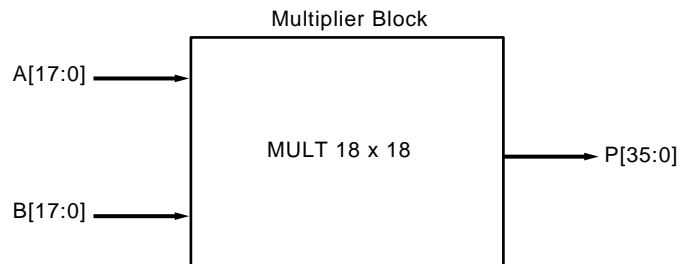

DS031_40_100400

Figure 34: Multiplier Block

Locations / Organization

Multiplier organization is identical to the 18-Kbit SelectRAM organization, because each multiplier is associated with an 18-Kbit block SelectRAM resource.

In addition to the built-in multiplier blocks, the CLB elements have dedicated logic to implement efficient multipliers in logic. (Refer to **Configurable Logic Blocks (CLBs)**).

Table 19: Multiplier Floor Plan

Device	Columns	Multipliers	
		Per Column	Total
XC2V40	2	2	4
XC2V80	2	4	8
XC2V250	4	6	24
XC2V500	4	8	32
XC2V1000	4	10	40
XC2V1500	4	12	48
XC2V2000	4	14	56
XC2V3000	6	16	96
XC2V4000	6	20	120
XC2V6000	6	24	144
XC2V8000	6	28	168
XC2V10000	6	32	192

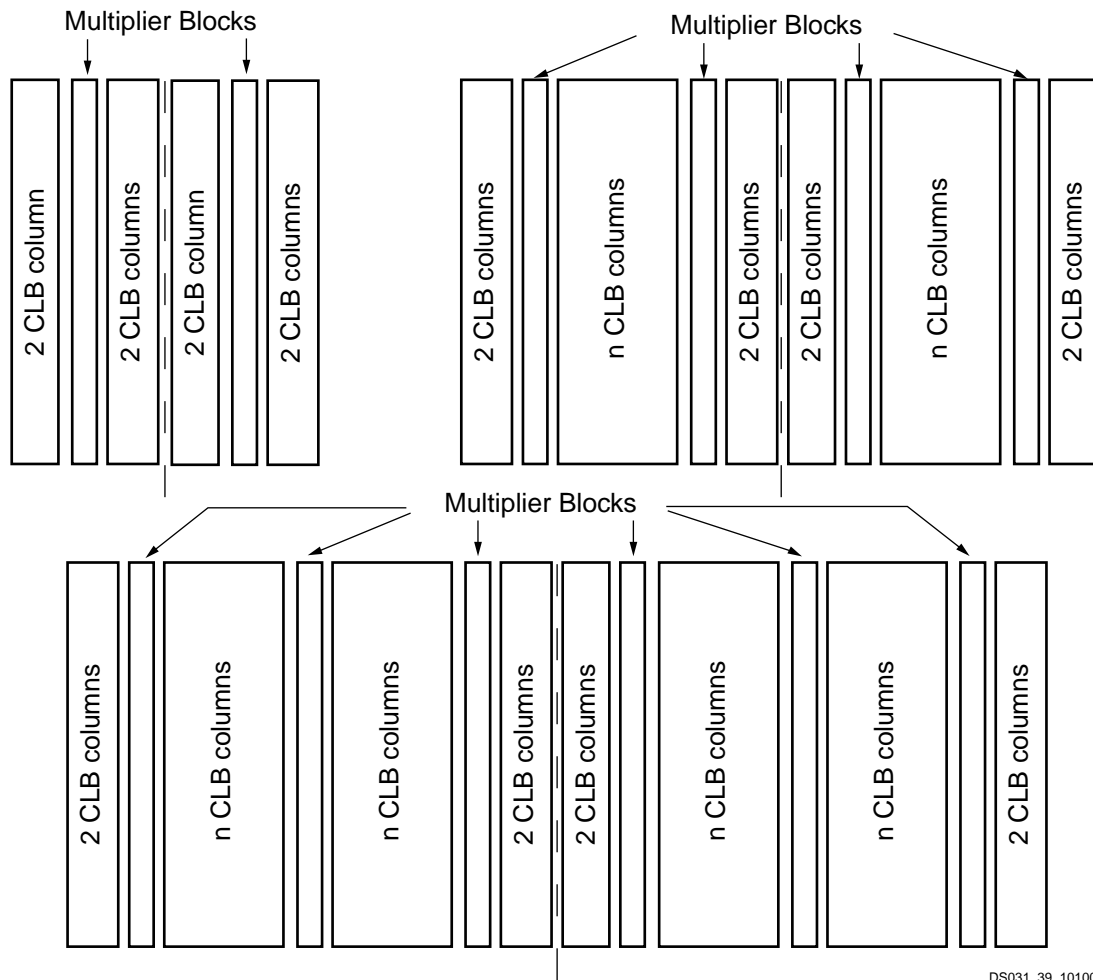

DS031_39_101000

Figure 35: Multipliers (2-column, 4-column, and 6-column)

Global Clock Multiplexer Buffers

Virtex-II devices have 16 clock input pins that can also be used as regular user I/Os. Eight clock pads are on the top edge of the device, in the middle of the array, and eight are on the bottom edge, as illustrated in Figure 36.

The global clock multiplexer buffer represents the input to dedicated low-skew clock tree distribution in Virtex-II devices. Like the clock pads, eight global clock multiplexer buffers are on the top edge of the device and eight are on the bottom edge.

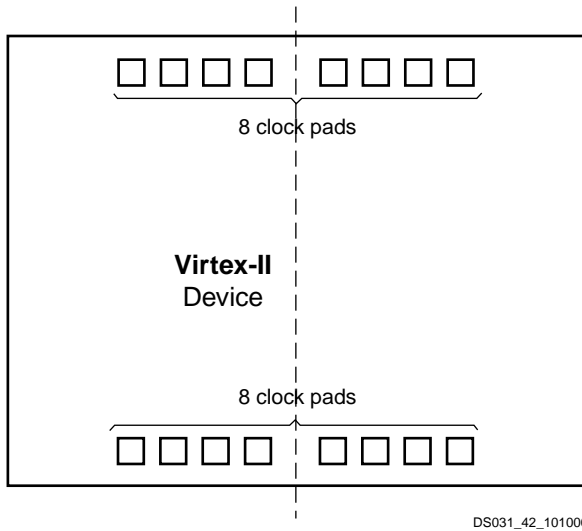

Figure 36: Virtex-II Clock Pads

Each global clock buffer can either be driven by the clock pad to distribute a clock directly to the device, or driven by the Digital Clock Manager (DCM), discussed in **Digital Clock Manager (DCM)**, page 27. Each global clock buffer

can also be driven by local interconnects. The DCM has clock output(s) that can be connected to global clock buffer inputs, as shown in Figure 37.

Global clock buffers are used to distribute the clock to some or all synchronous logic elements (such as registers in CLBs and IOBs, and SelectRAM blocks).

Eight global clocks can be used in each quadrant of the Virtex-II device. Designers should consider the clock distribution detail of the device prior to pin-locking and floorplanning (see the Virtex-II User Guide).

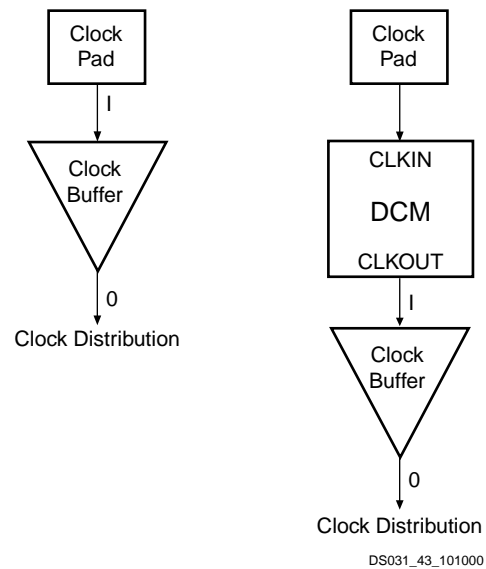

Figure 37: Virtex-II Clock Distribution Configurations

Figure 38 shows clock distribution in Virtex-II devices.

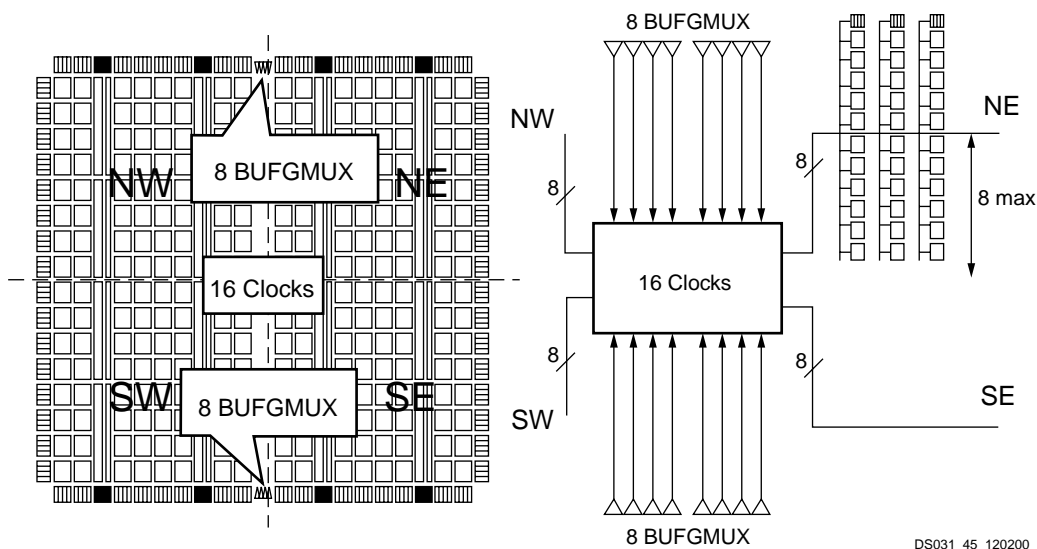

Figure 38: Virtex-II Clock Distribution

In each quadrant, up to eight clocks are organized in clock rows. A clock row supports up to 16 CLB rows (eight up and eight down). For the largest devices a new clock row is added, as necessary.

To reduce power consumption, any unused clock branches remain static.

The global clock multiplexer buffers have two clock inputs, a select input, and a clock output. The select input selects between I_0 and I_1 without generating glitches.

The most common configuration option of this element is as a buffer. A BUFG function in this (global buffer) mode, is shown in [Figure 39](#).

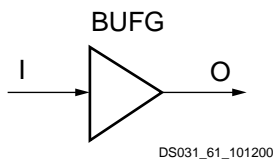

Figure 39: Virtex-II BUFG Function

In [Figure 40](#) the global buffer can also perform a clock enable function (clock gating). The CE input is synchronized inside the BUFG so any change in CE is only effective when the clock input is Low. This eliminates any glitches or runt pulses on the output, even when CE changes asynchronously to the clock.

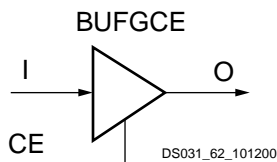

Figure 40: Virtex-II BUFGCE Function

The two clock inputs can be connected to any synchronous or asynchronous clock (from a clock pad or DCM clock output). When the select input (S) is Low, the clock connected to the I_0 input is distributed, as shown in [Figure 41](#). Setting S High, causes the clock connected to the I_1 input to be distributed.

The clock multiplexer can also switch between two unrelated clocks. The S input can be changed asynchronously to both clocks. Internal synchronization switches away for the

present clock when it is low but switches to the new clock only after the subsequent falling edge.

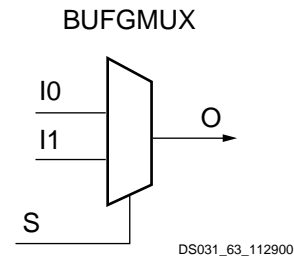

Figure 41: Virtex-II BUFGMUX Function

When S changes state, the transition on the output occurs without creating a runt pulse. The output pulse is never shorter than the I_0 or I_1 input pulse. The S input has a setup requirement.

The global clock multiplexer buffers has two options:

- Transition on Low clock states
- Transition on High clock states

The transition on Low follows different steps, as illustrated in [Figure 42](#).

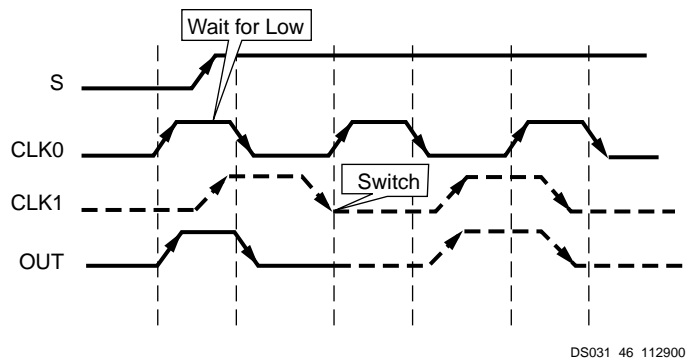

Figure 42: Clock Multiplexer Waveform Diagram

- The current clock is CLK0.
- S is activated High (setup is required before the next negative CLK0 edge).
- If CLK0 is currently High, the multiplexer waits for the next negative edge.
- Once CLK0 is Low, the multiplexer output stays Low, until CLK1 goes Low.
- When CLK1 transitions from High to Low, the output switches to CLK1.
- No glitches or short pulses can appear on the output.

The transition on High clock state is similar, with the positive edge of the second clock Low.

All Virtex-II devices have 16 global clock multiplexer buffers.

Digital Clock Manager (DCM)

The Virtex-II DCM offers a wide range of powerful clock management features.

- **Clock De-skew:** The DCM generates new system clocks (either internally or externally to the FPGA), which are phase-aligned to the input clock.
- **Frequency Synthesis:** The DCM generates a wide range of output clock frequencies, performing very flexible clock multiplication and division.
- **Phase Shifting:** The DCM provides both coarse phase shifting and fine-grained phase shifting with dynamic phase shift control.
- **EMI Reduction:** The DCM provides the capability to reduce electromagnetic interference (EMI) by broadening the output clock frequency spectrum.

The DCM utilizes fully digital delay lines allowing robust high-precision control of clock phase and frequency. It also utilizes fully digital feedback systems, operating dynamically to compensate for temperature and voltage variations during operation.

Up to four DCM clock outputs can drive global clock multiplexer buffer inputs simultaneously (see [Figure 43](#)). All DCM clock outputs can simultaneously drive general routing resources, including routes to output buffers.

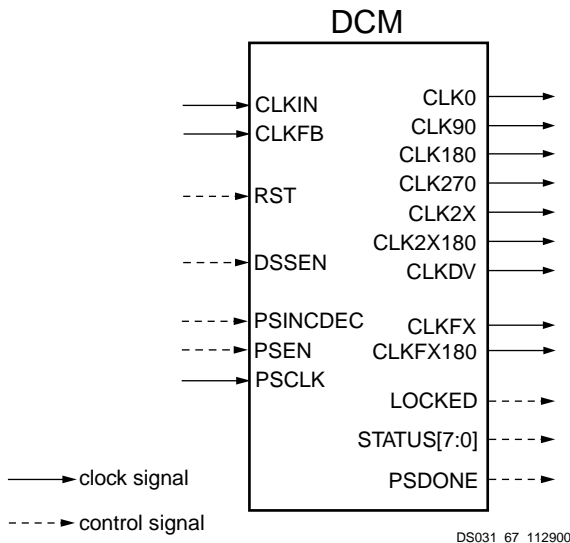

Figure 43: Digital Clock Manager

The DCM can be configured to delay the completion of the Virtex-II configuration process until after the DCM has achieved lock. This guarantees that the chip does not begin operating until after the system clocks generated by the DCM have stabilized.

The DCM has the following general control signals:

- **RST input pin:** resets the entire DCM
- **LOCKED output pin:** asserted High when all enabled DCM circuits have locked.
- **STATUS output pins (active High):** shown in [Table 20](#).

Table 20: DCM Status Pins

Status Pin	Function
0	Phase Shift Overflow
1	CLKIN Stopped
2	N/A
3	N/A
4	N/A
5	N/A
6	N/A
7	N/A

Clock De-Skew

The DCM de-skews the output clocks relative to the input clock by automatically adjusting a digital delay line. Additional delay is introduced so that clock edges arrive at internal registers and block RAM synchronous to clock edges arriving at the input. Alternatively, external clocks, which are also de-skewed relative to the input clock, can be generated for board-level routing. All DCM output clocks are phase-aligned to CLK0 and, therefore, are also phase-aligned to the input clock.

To achieve clock de-skew, the CLKFB input must be connected, and its source must be either CLK0 or CLK2X. Note that CLKFB must always be connected, unless only the CLKFX or CLKFX180 outputs are used and de-skew is not required.

Frequency Synthesis

The DCM provides flexible methods for generating new clock frequencies. Each method has a different operating frequency range and different AC characteristics. The CLK2X and CLK2X180 outputs can be used to double the clock frequency. The CLKDV output can be used to create divided output clocks with division options of 1.5, 2, 2.5, 3, 3.5, 4, 4.5, 5, 5.5, 6, 6.5, 7, 7.5, 8, 9, 10, 11, 12, 13, 14, 15, and 16.

The CLKFX and CLKFX180 outputs can be used to produce clocks at the following frequency:

$$FREQ_{CLKFX} = (M/D) * FREQ_{CLKIN}$$

where M and D are two integers, each between 1 and 4096. By default, M=4 and D=1, which results in a clock output frequency four times faster than the clock input frequency (CLKIN).

CLK2X180 is phase shifted 180 degrees relative to CLK2X. CLKFX180 is phase shifted 180 degrees relative to CLKFX. All frequency synthesis outputs automatically have 50/50 duty cycles (with the exception of the CLKDV output when performing a non-integer divide in high frequency mode).

Phase Shifting

The DCM provides additional control over clock skew through either coarse or fine-grained phase shifting. The CLK0, CLK90, CLK180, and CLK270 outputs are each phase shifted by $\frac{1}{4}$ of the input clock period relative to each other, allowing coarse phase adjustments.

Fine phase adjustment applies to all DCM output clocks when activated. The phase shift between the rising edges of CLKIN and CLKFB is configured to be a specified fraction of the input clock period, and it can be dynamically adjusted with the dedicated signals, PSINCDEC, PSEN, PSCLK, and PSDONE. The phase shift value (PS) is specified as an integer between -255 and $+255$. The amount of phase shift achieved is given by the equation:

$$\text{Phase shift} = (\text{PS}/256) * \text{PERIOD}_{\text{CLKIN}}$$

In variable mode, the PS value can be dynamically incremented or decremented according to PSINCDEC synchronously to PSCLK, when the PSEN input is active. Figure 44 illustrates the effects of fine phase shifting.

Table 21 lists fine phase shifting control pins, when used in variable mode.

Table 21: Fine Phase Shifting Control Pins

Control Pin	Direction	Function
PSINCDEC	in	Increment or decrement
PSEN	in	Enable \pm phase shift
PSCLK	in	Clock for phase shift
PSDONE	out	Active when completed

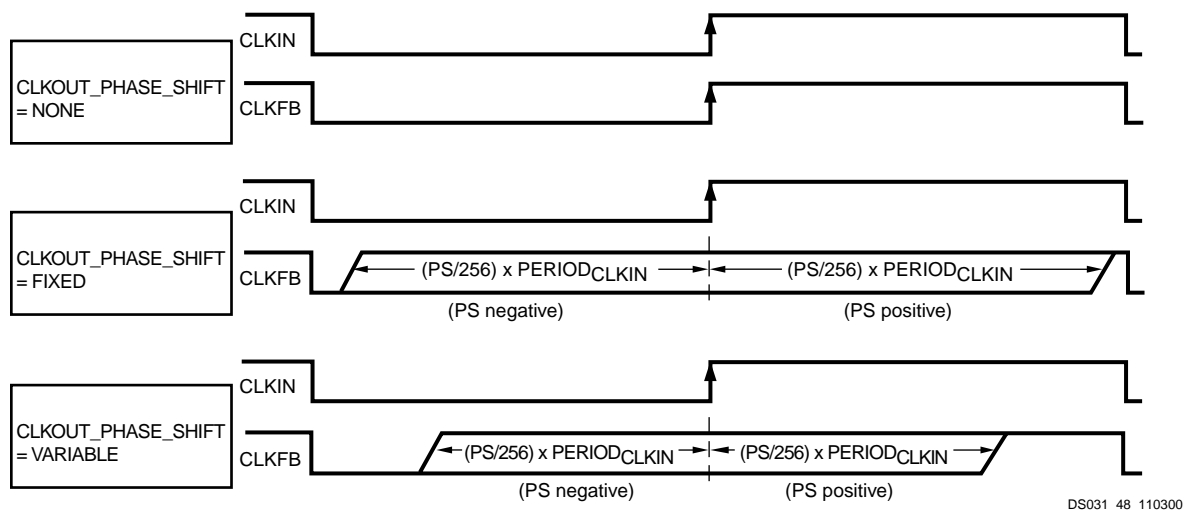

Figure 44: Fine Phase Shifting Effects

EMI Reduction

The DCM offers a Digital Spread Spectrum (DSS) feature that broadens the frequency spectrum of the clock outputs. The spectrum spreading applies directly to the CLK0, CLK90, CLK180, and CLK270 clock outputs when it is active. The other DCM clock outputs are affected to only a small degree. Spreading the spectrum of the clock frequency reduces the electromagnetic interference (EMI), or energy radiation, within the relevant frequency bandwidth. This technique aids in meeting FCC EMI regulations.

When enabled, spectrum spreading begins immediately after the LOCKED signal goes HIGH. The DSSSEN input can be used to enable/disable the feature during operation.

Table 22 lists available DSS options.

Table 22: DSS Options

Number of Frequencies Added	Mode	Clock Period Range
2	SPREAD_2	$\pm 1 \times \text{DCM_TAP}$
4	SPREAD_4	$\pm 2 \times \text{DCM_TAP}$
6	SPREAD_6	$\pm 3 \times \text{DCM_TAP}$
8	SPREAD_8	$\pm 4 \times \text{DCM_TAP}$

Notes:

1. DCM_TAP value is defined in the AC characteristics section

Operating Modes

The frequency ranges of the DCM input and output clocks depend on the operating mode specified, either low frequency mode or high frequency mode, according to

Table 23, page 29. (For actual values, see **Virtex-II Switching Characteristics**). The CLK2X, CLK2X180, CLK90, and CLK270 outputs are not available in high frequency mode.

Table 23: DCM Frequency Ranges

Output Clock	Low-Frequency Mode		High-Frequency Mode	
	CLKIN Input	CLK Output	CLKIN Input	CLK Output
CLK0, CLK180	CLKIN_FREQ_DLL_LF	CLKOUT_FREQ_1X_LF	CLKIN_FREQ_DLL_HF	CLKOUT_FREQ_1X_HF
CLK90, CLK270	CLKIN_FREQ_DLL_LF	CLKOUT_FREQ_1X_LF	NA	NA
CLK2X, CLK2X180	CLKIN_FREQ_DLL_LF	CLKOUT_FREQ_2X_LF	NA	NA
CLKDV	CLKIN_FREQ_DLL_LF	CLKOUT_FREQ_DV_LF	CLKIN_FREQ_DLL_HF	CLKOUT_FREQ_DV_HF
CLKFX, CLKFX180	CLKIN_FREQ_FX_LF	CLKOUT_FREQ_FX_LF	CLKIN_FREQ_FX_HF	CLKOUT_FREQ_FX_HF

Locations/Organization

Virtex-II DCMs are placed on the top and bottom of each block RAM and multiplier column. The number of DCMs depends on the device size, as shown in Table 24.

Table 24: DCM Organization

Device	Columns	DCMs
XC2V40	2	4
XC2V80	2	4
XC2V250	4	8
XC2V500	4	8
XC2V1000	4	8
XC2V1500	4	8
XC2V2000	4	8
XC2V3000	6	12
XC2V4000	6	12
XC2V6000	6	12
XC2V8000	6	12
XC2V10000	6	12

Active Interconnect Technology

Local and global Virtex-II routing resources are optimized for speed and timing predictability, as well as to facilitate IP cores implementation. Virtex-II Active Interconnect Technology is a fully buffered programmable routing matrix. All routing resources are segmented to offer the advantages of a hierarchical solution. Virtex-II logic features like CLBs, IOBs, block RAM, multipliers, and DCMs are all connected to an identical switch matrix for access to global routing resources, as shown in Figure 45.

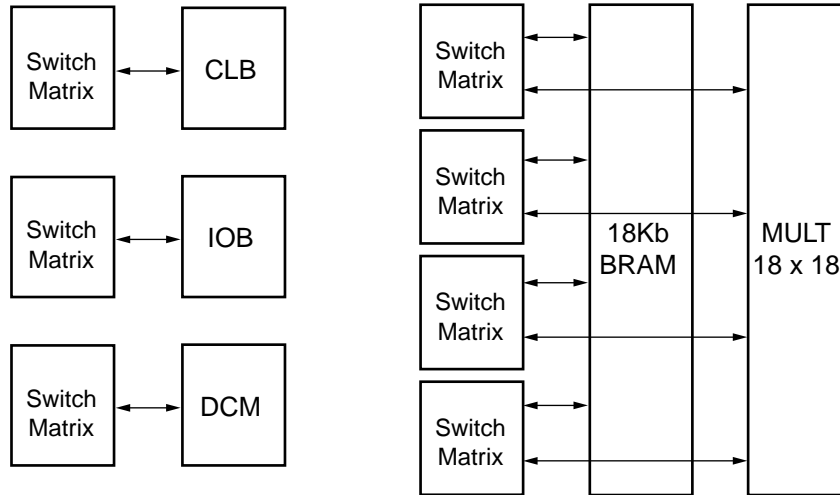

DS031_55_101000

Figure 45: Active Interconnect Technology

Each Virtex-II device can be represented as an array of switch matrixes with logic blocks attached, as illustrated in Figure 46.

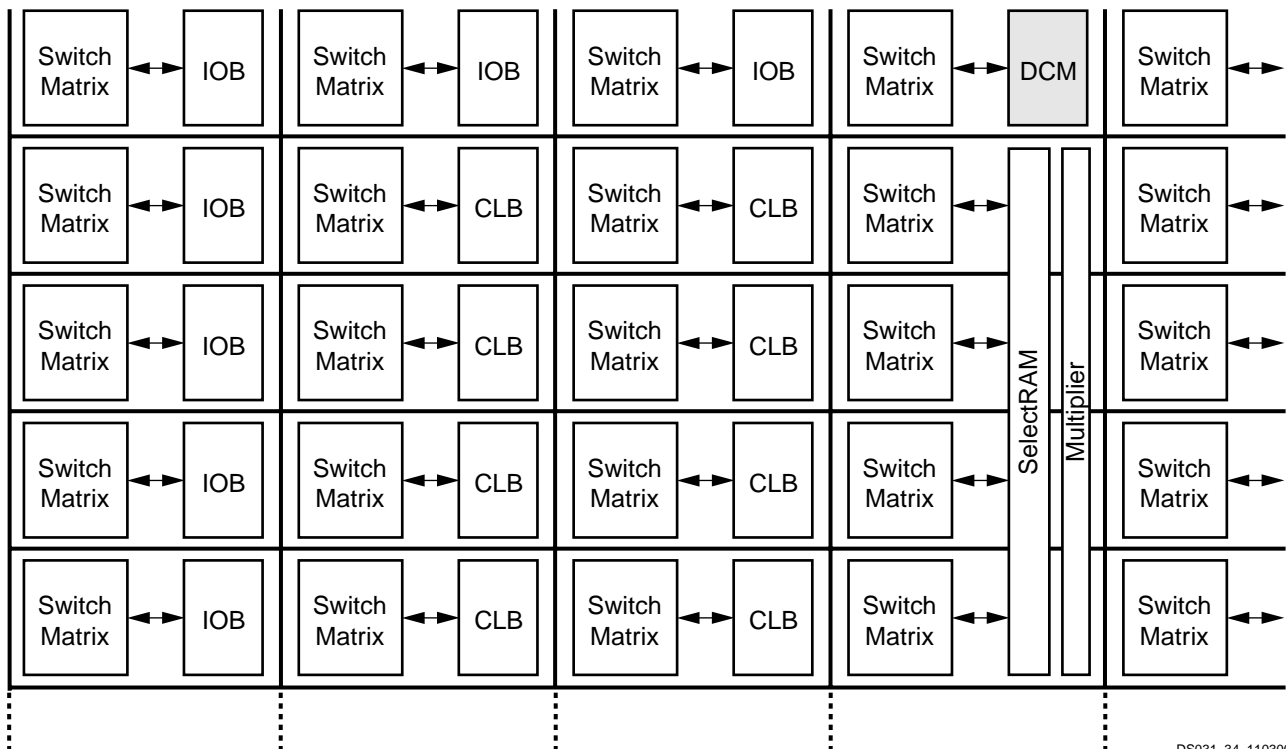

DS031_34_110300

Figure 46: Routing Resources

Place-and-route software takes advantage of this regular array to deliver optimum system performance and fast compile times. The segmented routing resources are essential to guarantee IP cores portability and to efficiently handle an

incremental design flow that is based on modular implementations. Total design time is reduced due to fewer and shorter design iterations.

Hierarchical Routing Resources

Most Virtex-II signals are routed using the global routing resources, which are located in horizontal and vertical routing channels between each switch matrix.

As shown in Figure 46, Virtex-II has fully buffered programmable interconnections, with a number of resources counted between any two adjacent switch matrix rows or columns. Fanout has minimal impact on the performance of each net.

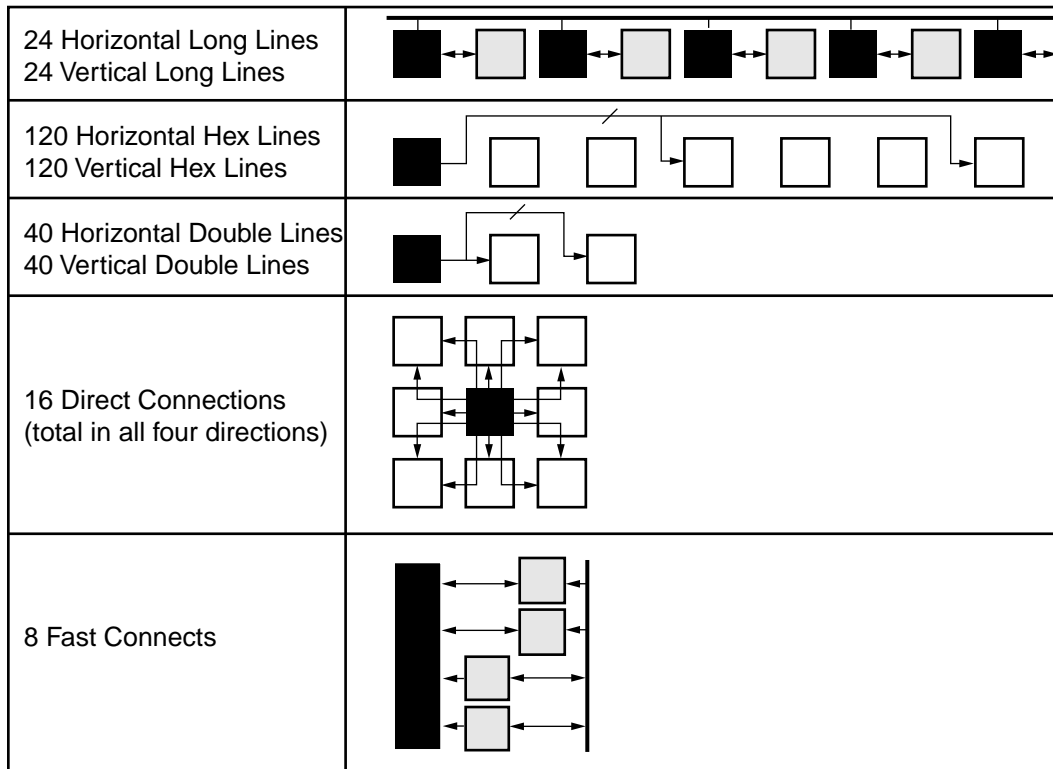

DS031_60_110200

Figure 47: Hierarchical Routing Resources

- The long lines are bidirectional wires that distribute signals across the device. Vertical and horizontal long lines span the full height and width of the device.
- The hex lines route signals to every third or sixth block away in all four directions. Organized in a staggered pattern, hex lines can only be driven from one end. Hex-line signals can be accessed either at the endpoints or at the midpoint (three blocks from the source).
- The double lines route signals to every first or second block away in all four directions. Organized in a staggered pattern, double lines can be driven only at their endpoints. Double-line signals can be accessed either at the endpoints or at the midpoint (one block from the source).
- The direct connect lines route signals to neighboring

- blocks: vertically, horizontally, and diagonally.
- The fast connect lines are the internal CLB local interconnections from LUT outputs to LUT inputs.

Dedicated Routing

In addition to the global and local routing resources, dedicated signals are available.

- There are eight global clock nets per quadrant (see **Global Clock Multiplexer Buffers**).
- Horizontal routing resources are provided for on-chip 3-state busses. Four partitionable bus lines are provided per CLB row, permitting multiple busses within a row. (See **3-State Buffers**.)
- Two dedicated carry-chain resources per slice column (two per CLB column) propagate carry-chain MUXCY

output signals vertically to the adjacent slice. (See **CLB/Slice Configurations**.)

- One dedicated SOP chain per slice row (two per CLB row) propagate ORCY output logic signals horizontally to the adjacent slice. (See **Sum of Products**.)
- One dedicated shift-chain per CLB connects the output of LUTs in shift-register mode to the input of the next LUT in shift-register mode (vertically) inside the CLB. (See **Shift Registers**, page 12.)

Creating a Design

Creating Virtex-II designs is easy with Xilinx development systems, supporting advanced design capabilities including incremental synthesis, modular design, integrated logic analysis, and the fastest place and route runtimes in the industry. This means designers get the performance they need, quickly.

As a result of the ongoing cooperative development efforts between Xilinx and EDA Alliance partners, designers can take advantage of the benefits provided by EDA technologies in the programmable logic design process. Xilinx development systems are available in a number of easy to use configurations within the Alliance Series and Foundation Series product families.

Alliance Series Solutions

Alliance Series solutions are designed to plug and play within a chosen design environment. Built using industry standard data formats and netlists, these stable, flexible products also enable Alliance EDA partners to deliver their best design automation capabilities to Xilinx customers, providing incremental synthesis, modular design, and error navigation -- all features developed with Xilinx EDA partners, for use with Xilinx development systems first.

Foundation Series Solutions

Foundation Series solutions feature Foundation Integrated Synthesis Environment (ISE) tools, a family of products that deliver all of the benefits of true HDL-based design in a seamlessly integrated design environment. An intuitive project navigator, as well as powerful HDL design and two HDL synthesis tools, ensure that high-quality results are achieved quickly and easily. The Foundation ISE product includes:

- State Diagram entry using StateCAD XE
- Automatic HDL Testbench generation using HDLBencher XE
- HDL Simulation using ModelSim XE-starter (MXE-starter).

MXE Starter is particularly useful in demonstrating the seamless integration available between the ISE design environment and ModelSim HDL Simulation tools.

Design Flow

Virtex-II design flow proceeds as follows:

- Design Entry
- Synthesis
- Implementation
- Verification

Most programmable logic designers iterate through these steps several times in the process of completing a design.

Design Entry

Xilinx development systems support the mainstream EDA design entry capabilities, ranging from schematic design to advanced HDL design methodologies. Given the high densities of the Virtex-II family, designs are most efficiently created using HDLs. To improve efficiency, many Xilinx customers employ incremental, modular, and Intellectual Property (IP) design techniques. When properly used, these techniques further accelerate the logic design process.

To enable designers to leverage existing investments in EDA tools, and to ensure high performance design flows, Xilinx jointly develops tools with leading EDA vendors, including:

- Aldec
- Cadence
- Exemplar
- Mentor Graphics
- Model Technology
- Synopsys
- Synplicity
- VSS

Complete information on Alliance Series partners and their associated design flows is available from the Xilinx Alliance Series web page:

www.xilinx.com/products/alliance.htm

Xilinx Foundation Series products offer schematic entry and HDL design capabilities as part of an integrated design solution - enabling one-stop shopping. These capabilities are powerful, easy to use, and they support the full portfolio of Xilinx programmable logic devices. HDL design capabilities include a color-coded HDL editor with integrated language templates, state diagram entry, and Core generation capabilities.

Synthesis

Alliance Series products are engineered to support advanced design flows with the industry's best synthesis tools for:

- Incremental synthesis
- RTL floorplanning
- Automated timing convergence
- Direct physical mapping

The Xilinx Foundation ISE product family includes synthesis capabilities from both FPGA Express and a proprietary synthesis tool referred to as Xilinx Synthesis Technology. Having two seamlessly integrated synthesis engines within the Foundation ISE products provides an alternative set of optimization techniques for designs, helping to ensure that Foundation ISE can meet even the toughest timing requirements.

Both FPGA Express and Xilinx Synthesis Technology support the synthesis of VHDL and Verilog; however, only FPGA Express enables mixed-language synthesis. Future releases of the ISE design environment are planned to also integrate other third party synthesis tools, like Synplicity Synplify and Exemplar's Leonardo Spectrum.

Design Implementation

The Alliance Series and Foundation Series development systems both include Xilinx timing-driven implementation tools, frequently called "place and route" software. This robust suite of tools enables the creation of an intuitive, flexible, tightly integrated design flow that efficiently bridges the "logical" and "physical" design domains. This simplifies the task of defining a design, including its behavior, timing requirements, and optional layout (or floorplanning), as well as simplifying the task of analyzing reports generated during the implementation process.

The Virtex-II implementation process is comprised of Synthesis, translation, mapping, place and route, and configuration file generation. While the tools can be run individually, many designers choose to run the entire implementation process with the click of a button. To assist those who prefer to script their design flows, Xilinx provides Xflow, an automated single command line process.

Design Verification

In addition to conventional design verification using static timing analysis or dynamic timing analysis (simulation), powerful in-circuit debugging techniques using Xilinx ChipScope ILA (Integrated Logic Analysis) is available. In these reconfigurable Xilinx FPGAs, designs can be verified in real time without the need for extensive sets of software simulation vectors. The development system supports both software simulation and in-circuit debugging techniques.

For simulation, the system extracts post-layout timing information from the design database, and back-annotates this information into the netlist for use by the simulator. The back annotation features a variety of patented Xilinx techniques, resulting in the industry's most powerful simulation flows. Alternatively, the user can verify timing-critical portions of a design using the TRCE® static timing analyzer, or using a third party static timing analysis tool by exporting timing data in the STAMP data format.

For in-circuit debugging, ChipScope ILA enables designers to analyze the real-time behavior of a device while operating at full system speeds. Logic analysis commands and captured data are transferred between the ChipScope software

and ILA cores within the Virtex-II FPGA, using industry standard JTAG protocols. These JTAG transactions are driven over an optional download cable (MultiLINX or JTAG), connecting the Virtex device in the target system to a PC or workstation.

ChipScope ILA was designed to look and feel like a logic analyzer, making it easy to begin debugging a design immediately. Modifications to the desired logic analysis can be downloaded into the system in a matter of minutes.

Other Unique Features of Virtex-II Design Flow

Xilinx design flows feature a number of unique capabilities. Among these are efficient incremental HDL design flows; a robust capability that is enabled by Xilinx exclusive hierarchical floorplanning capabilities. Another powerful design capability only available in the Xilinx design flow is "Modular Design", part of the Xilinx suite of team design tools, which enables autonomous design, implementation, and verification of design modules.

Incremental Synthesis

Xilinx unique hierarchical floorplanning capabilities enable designers to create a programmable logic design by isolating design changes within one hierarchical "logic block", and perform synthesis, verification and implementation processes on that specific logic block. By preserving the logic in unchanged portions of a design, Xilinx incremental design makes the high-density design process more efficient.

Xilinx hierarchical floorplanning capabilities can be specified using the high-level floorplanner or a preferred RTL floorplanner (see the Xilinx web site for a list of supported EDA partners). When used in conjunction with one of the EDA partners' floorplanners, higher performance results can be achieved, as many synthesis tools use this more predictable detailed physical implementation information to establish more aggressive and accurate timing estimates when performing their logic optimizations.

Modular Design

Xilinx innovative modular design capabilities take the incremental design process one step further by enabling the designer to delegate responsibility for completing the design, synthesis, verification, and implementation of a hierarchical "logic block" to an arbitrary number of designers - assigning a specific region within the target FPGA for exclusive use by each of the team members.

This team design capability enables an autonomous approach to design modules, changing the hand-off point to the lead designer or integrator from "my module works in simulation" to "my module works in the FPGA". This unique design methodology also leverages the Xilinx hierarchical floorplanning capabilities and enables the Xilinx (or EDA partner) floorplanner to manage the efficient implementation of very high-density FPGAs.

Configuration

Virtex-II devices are configured by loading application specific configuration data into the internal configuration memory. Configuration is carried out using a subset of the device pins, some of which are dedicated, while others can be re-used as general purpose inputs and outputs once configuration is complete.

Depending on the system design, several configuration modes are supported, selectable via mode pins. The mode pins M2, M1 and M0 are dedicated pins. An additional pin, HSWAP_EN is used in conjunction with the mode pins to select whether user I/O pins have pull-ups during configuration. By default, HSWAP_EN is tied High (internal pull-up) which shuts off the pull-ups on the user I/O pins during configuration. When HSWAP_EN is tied Low, user I/Os have pull-ups during configuration. Other dedicated pins are CCLK (the configuration clock pin), DONE, PROG_B, and the boundary-scan pins: TDI, TDO, TMS, and TCK. Depending on the configuration mode chosen, CCLK can be an output generated by the FPGA, or an input accepting an externally generated clock. The configuration pins and boundary scan pins are independent of the V_{CCO} . The auxiliary power supply (V_{CCAUX}) of 3.3V is used for these pins. (See **Virtex-II DC Characteristics**.)

A persist option is available which can be used to force the configuration pins to retain their configuration function even after device configuration is complete. If the persist option is not selected then the configuration pins with the exception of CCLK, PROG_B, and DONE can be used as user I/O in normal operation. The persist option does not apply to the boundary-scan related pins. The persist feature is valuable in applications which employ partial reconfiguration or reconfiguration on the fly.

Configuration Modes

Virtex-II supports the following five configuration modes:

- Slave-serial mode
- Master-serial mode
- Slave SelectMAP mode
- Master SelectMAP mode
- Boundary-Scan mode (IEEE 1532/IEEE 1149)

A detailed description of configuration modes is provided in the *Virtex-II User Guide*.

Slave-Serial Mode

In slave-serial mode, the FPGA receives configuration data in bit-serial form from a serial PROM or other serial source of configuration data. The CCLK pin on the FPGA is an input in this mode. The serial bitstream must be setup at the DIN input pin a short time before each rising edge of the externally generated CCLK.

Multiple FPGAs can be daisy-chained for configuration from a single source. After a particular FPGA has been configured, the data for the next device is routed internally to the DOUT pin. The data on the DOUT pin changes on the rising edge of CCLK.

Slave-serial mode is selected by applying <111> to the mode pins (M2, M1, M0). A weak pull-up on the mode pins makes slave serial the default mode if the pins are left unconnected.

Master-Serial Mode

In master-serial mode, the CCLK pin is an output pin. It is the Virtex-II FPGA device that drives the configuration clock on the CCLK pin to a Xilinx Serial PROM which in turn feeds bit-serial data to the DIN input. The FPGA accepts this data on each rising CCLK edge. After the FPGA has been loaded, the data for the next device in a daisy-chain is presented on the DOUT pin after the rising CCLK edge.

The interface is identical to slave serial except that an internal oscillator is used to generate the configuration clock (CCLK). A wide range of frequencies can be selected for CCLK which always starts at a slow default frequency. Configuration bits then switch CCLK to a higher frequency for the remainder of the configuration.

Slave SelectMAP Mode

The SelectMAP mode is the fastest configuration option. Byte-wide data is written into the Virtex-II FPGA device with a BUSY flag controlling the flow of data. An external data source provides a byte stream, CCLK, an active Low Chip Select (CS_B) signal and a Write signal (RDWR_B). If BUSY is asserted (High) by the FPGA, the data must be held until BUSY goes Low. Data can also be read using the SelectMAP mode. If RDWR_B is asserted, configuration data is read out of the FPGA as part of a readback operation.

After configuration, the pins of the SelectMAP port can be used as additional user I/O. Alternatively, the port can be retained to permit high-speed 8-bit readback using the persist option.

Multiple Virtex-II FPGAs can be configured using the SelectMAP mode, and be made to start-up simultaneously. To configure multiple devices in this way, wire the individual CCLK, Data, RDWR_B, and BUSY pins of all the devices in parallel. The individual devices are loaded separately by deasserting the CS_B pin of each device in turn and writing the appropriate data.

Master SelectMAP Mode

This mode is a master version of the SelectMAP mode. The device is configured byte-wide on a CCLK supplied by the Virtex-II FPGA device. Timing is similar to the Slave Serial-MAP mode except that CCLK is supplied by the Virtex-II FPGA.

Boundary-Scan (JTAG, IEEE 1532) Mode

In boundary-scan mode, dedicated pins are used for configuring the Virtex-II device. The configuration is done entirely through the IEEE 1149.1 Test Access Port (TAP). Virtex-II device configuration using Boundary scan is compliant with IEEE 1149.1-1993 standard and the new IEEE 1532 standard for In-System Configurable (ISC) devices. The IEEE 1532 standard is backward compliant with the IEEE 1149.1-1993 TAP and state machine. The IEEE Standard 1532 for In-System Configurable (ISC) devices is intended to be programmed, reprogrammed, or tested on the board via a physical and logical protocol.

Configuration through the boundary-scan port is always available, independent of the mode selection. Selecting the boundary-scan mode simply turns off the other modes.

Table 25: Virtex-II Configuration Mode Pin Settings

Configuration Mode ⁽¹⁾	M2	M1	M0	CCLK Direction	Data Width	Serial D _{OUT} ⁽²⁾
Master Serial	0	0	0	Out	1	Yes
Slave Serial	1	1	1	In	1	Yes
Master SelectMAP	0	1	1	Out	8	No
Slave SelectMAP	1	1	0	In	8	No
Boundary Scan	1	0	1	N/A	1	No

Notes:

1. The HSWAP_EN pin controls the pullups. Setting M2, M1, and M0 selects the configuration mode, while the HSWAP_EN pin controls whether or not the pullups are used.
2. Daisy chaining is possible only in modes where Serial D_{OUT} is used. For example, in SelectMAP modes, the first device does NOT support daisy chaining of downstream devices.

Table 26 lists the total number of bits required to configure each device.

Table 26: Virtex-II Bitstream Lengths

Device	# of Configuration Bits
XC2V40	338,208
XC2V80	597,408
XC2V250	1,591,584
XC2V500	2,557,856
XC2V1000	3,749,408
XC2V1500	5,166,240
XC2V2000	6,808,352
XC2V3000	9,589,408
XC2V4000	14,220,192
XC2V6000	19,752,096
XC2V8000	26,185,120
XC2V10000	33,519,264

Configuration Sequence

The configuration of Virtex-II devices is a three-phase process. First, the configuration memory is cleared. Next, configuration data is loaded into the memory, and finally, the logic is activated by a start-up process.

Configuration is automatically initiated on power-up unless it is delayed by the user. The INIT_B pin can be held Low

using an open-drain driver. An open-drain is required since INIT_B is a bidirectional open-drain pin that is held Low by a Virtex-II FPGA device while the configuration memory is being cleared. Extending the time that the pin is Low causes the configuration sequencer to wait. Thus, configuration is delayed by preventing entry into the phase where data is loaded.

The configuration process can also be initiated by asserting the PROG_B pin. The end of the memory-clearing phase is signaled by the INIT_B pin going High, and the completion of the entire process is signaled by the DONE pin going High. The Global Set/Reset (GSR) signal is pulsed after the last frame of configuration data is written but before the start-up sequence. The GSR signal resets all flip-flops on the device.

The default start-up sequence is that one CCLK cycle after DONE goes High, the global 3-state signal (GTS) is released. This permits device outputs to turn on as necessary. One CCLK cycle later, the Global Write Enable (GWE) signal is released. This permits the internal storage elements to begin changing state in response to the logic and the user clock.

The relative timing of these events can be changed via configuration options in software. In addition, the GTS and GWE events can be made dependent on the DONE pins of multiple devices all going High, forcing the devices to start synchronously. The sequence can also be paused at any stage, until lock has been achieved on any or all DCMs, as well as the DCI.

Readback

In this mode, configuration data from the Virtex-II FPGA device can be read back. Readback is supported only in the SelectMAP (master and slave) and Boundary Scan mode.

Along with the configuration data, it is possible to read back the contents of all registers, distributed SelectRAM, and block RAM resources. This capability is used for real-time debugging. For more detailed configuration information, see the *Virtex-II User Guide*.

Bitstream Encryption

Virtex-II devices have an on-chip decryptor using one or two sets of three keys for triple-key Data Encryption Standard (DES) operation. Xilinx software tools offer an optional encryption of the configuration data (bitstream) with a triple-key DES determined by the designer.

The keys are stored in the FPGA by JTAG instruction and retained by a battery connected to the V_{BATT} pin, when the device is not powered. Virtex-II devices can be configured with the corresponding encrypted bitstream, using any of the configuration modes described previously.

A detailed description of how to use bitstream encryption is provided in the *Virtex-II User Guide*.

Partial Reconfiguration

Partial reconfiguration of Virtex-II devices can be accomplished in either Slave SelectMAP mode or Boundary-Scan mode. Instead of resetting the chip and doing a full configuration, new data is loaded into a specified area of the chip, while the rest of the chip remains in operation. Data is

loaded on a column basis, with the smallest load unit being a configuration “frame” of the bitstream (device size dependent).

Partial reconfiguration is useful for applications that require different designs to be loaded into the same area of a chip, or that require the ability to change portions of a design without having to reset or reconfigure the entire chip.

Power-Down Sequence

The power-down sequence enables a designer to set the device into a low-power, inactive state. The sequence is initiated by pulling the PWRDWN_B pin Low.

If the PWRDWN_STAT option is selected using BitGen, the DONE pin can serve as the power-down status pin. When asserted, power-down has completed. After a successful wake-up, the status pin deasserts. While powered down, the only active pins are the PWRDWN_B and DONE. All inputs are off and all outputs are 3-stated.

While in the POWERDOWN state, the Power On Reset (POR) circuit is still active, but it does not reset the device if V_{CCINT} , V_{CCO} , or V_{CCAUX} falls below its minimum value. The POR circuit waits until the PWRDWN_B pin is released before resetting the device. Also, the PROG_B pin is not sampled while the device is in the POWERDOWN state. The PROG_B pin becomes active when the PWRDWN_B pin is released. Therefore, the device cannot be reset while in the POWERDOWN state.

The wake-up sequence is the reverse of the power-down sequence.

Revision History

This section records the change history for this module of the data sheet.

Date	Version	Revision
11/07/00	1.0	Early access draft.
12/06/00	1.1	Initial release.
01/15/01	1.2	Added values to the tables in the Virtex-II Performance Characteristics and Virtex-II Switching Characteristics sections.
01/25/01	1.3	The data sheet was divided into four modules (per the current style standard). A note was added to Table 1, “Supported Single-Ended I/O Standards,” on page 1.
04/02/01	1.5	<ul style="list-style-type: none"> Under Input/Output Individual Options, page 4, the range of values for optional pull-up and pull-down resistors was changed to 10 - 60 KΩ from 50 - 100 KΩ. Skipped v1.4 to sync up modules. Reverted to traditional double-column format.

Virtex-II Data Sheet

The Virtex-II Data Sheet contains the following modules:

- DS031-1, Virtex-II 1.5V FPGAs: [Introduction and Ordering Information \(Module 1\)](#)
- DS031-2, Virtex-II 1.5V FPGAs: Functional Description (Module 2)
- DS031-3, Virtex-II 1.5V FPGAs: [DC and Switching Characteristics \(Module 3\)](#)
- DS031-4, Virtex-II 1.5V FPGAs: [Pinout Tables \(Module 4\)](#)