

JTAG Programmer Guide

Introduction

Hardware

JTAG Programmer Tutorial

***Designing Boundary-Scan
and ISP Systems***

Boundary Scan Basics

***JTAG Parallel Cable
Schematic***

Troubleshooting Guide

Error Messages

***Using the Command Line
Interface***

***Standard Methodologies for
Instantiating the BSCAN
Symbol***



The Xilinx logo shown above is a registered trademark of Xilinx, Inc.

ASYL, FPGA Architect, FPGA Foundry, NeoCAD, NeoCAD EPIC, NeoCAD PRISM, NeoROUTE, Timing Wizard, TRACE, XACT, XILINX, XC2064, XC3090, XC4005, XC5210, and XC-DS501 are registered trademarks of Xilinx, Inc.



The shadow X shown above is a trademark of Xilinx, Inc.

All XC-prefix product designations, A.K.A Speed, Alliance Series, AllianceCORE, BITA, CLC, Configurable Logic Cell, CoolRunner, CORE Generator, CoreLINUX, Dual Block, EZTag, FastCLK, FastCONNECT, FastFLASH, FastMap, Fast Zero Power, Foundation, HardWire, IRL, LCA, LogiBLOX, Logic Cell, LogiCORE, LogicProfessor, MicroVia, MultiLINUX, PLUSASM, PowerGuide, PowerMaze, QPro, RealPCI, RealPCI 64/66, SelectI/O, SelectRAM, SelectRAM+, Silicon Xpresso, Smartguide, Smart-IP, SmartSearch, Smartspec, SMARTSwitch, Spartan, TrueMap, UIM, VectorMaze, VersaBlock, VersaRing, Virtex, WebFitter, WebLINUX, WebPACK, XABEL, XACT^{step}, XACT^{step} Advanced, XACT^{step} Foundry, XACT-Floorplanner, XACT-Performance, XAM, XAPP, X-BLOX, X-BLOX plus, XChecker, XDM, XDS, XEPLD, Xilinx Foundation Series, XPP, XSI, and ZERO+ are trademarks of Xilinx, Inc. The Programmable Logic Company and The Programmable Gate Array Company are service marks of Xilinx, Inc.

All other trademarks are the property of their respective owners.

Xilinx, Inc. does not assume any liability arising out of the application or use of any product described or shown herein; nor does it convey any license under its patents, copyrights, or maskwork rights or any rights of others. Xilinx, Inc. reserves the right to make changes, at any time, in order to improve reliability, function or design and to supply the best product possible. Xilinx, Inc. will not assume responsibility for the use of any circuitry described herein other than circuitry entirely embodied in its products. Xilinx, Inc. devices and products are protected under one or more of the following U.S. Patents: 4,642,487; 4,695,740; 4,706,216; 4,713,557; 4,746,822; 4,750,155; 4,758,985; 4,820,937; 4,821,233; 4,835,418; 4,855,619; 4,855,669; 4,902,910; 4,940,909; 4,967,107; 5,012,135; 5,023,606; 5,028,821; 5,047,710; 5,068,603; 5,140,193; 5,148,390; 5,155,432; 5,166,858; 5,224,056; 5,243,238; 5,245,277; 5,267,187; 5,291,079; 5,295,090; 5,302,866; 5,319,252; 5,319,254; 5,321,704; 5,329,174; 5,329,181; 5,331,220; 5,331,226; 5,332,929; 5,337,255; 5,343,406; 5,349,248; 5,349,249; 5,349,250; 5,349,691; 5,357,153; 5,360,747; 5,361,229; 5,362,999; 5,365,125; 5,367,207; 5,386,154; 5,394,104; 5,399,924; 5,399,925; 5,410,189; 5,410,194; 5,414,377; 5,422,833; 5,426,378; 5,426,379; 5,430,687; 5,432,719; 5,448,181; 5,448,493; 5,450,021; 5,450,022; 5,453,706; 5,455,525; 5,466,117; 5,469,003; 5,475,253; 5,477,414; 5,481,206; 5,483,478; 5,486,707; 5,486,776; 5,488,316; 5,489,858; 5,489,866; 5,491,353; 5,495,196; 5,498,979; 5,498,989; 5,499,192; 5,500,608; 5,500,609; 5,502,000; 5,502,440; 5,504,439; 5,506,518; 5,506,523; 5,506,878; 5,513,124; 5,517,135; 5,521,835; 5,521,837; 5,523,963; 5,523,971; 5,524,097; 5,526,322; 5,528,169; 5,528,176; 5,530,378; 5,530,384; 5,546,018; 5,550,839; 5,550,843; 5,552,722; 5,553,001; 5,559,751; 5,561,367; 5,561,629; 5,561,631; 5,563,527; 5,563,528; 5,563,529; 5,563,827; 5,565,792; 5,566,123; 5,570,051; 5,574,634; 5,574,655; 5,578,946; 5,581,198; 5,581,199; 5,581,738; 5,583,450; 5,583,452; 5,592,105; 5,594,352; 5,598,424; 5,600,263; 5,600,264; 5,600,271; 5,600,597; 5,608,342; 5,610,536; 5,610,790; 5,610,829; 5,612,633; 5,617,021; 5,617,041; 5,617,327; 5,617,573; 5,623,387; 5,627,480; 5,629,637; 5,629,886; 5,631,577; 5,631,583; 5,635,851; 5,636,368; 5,640,106; 5,642,058; 5,646,545; 5,646,547; 5,646,564; 5,646,903; 5,648,732; 5,648,913; 5,650,672; 5,650,946; 5,652,904; 5,654,631; 5,656,950; 5,657,290; 5,659,484; 5,661,660; 5,661,685; 5,670,896; 5,670,897; 5,672,966; 5,673,198; 5,675,262; 5,675,270; 5,675,589; 5,677,638; 5,682,107; 5,689,133; 5,689,516; 5,691,907; 5,691,912; 5,694,047; 5,694,056; 5,724,276; 5,694,399; 5,696,454; 5,701,091; 5,701,441; 5,703,759; 5,705,932; 5,705,938; 5,708,597; 5,712,579; 5,715,197; 5,717,340; 5,719,506; 5,719,507; 5,724,276; 5,726,484; 5,726,584; 5,734,866; 5,734,868; 5,737,234; 5,737,235;

5,737,631; 5,742,178; 5,742,531; 5,744,974; 5,744,979; 5,744,995; 5,748,942; 5,748,979; 5,752,006; 5,752,035; 5,754,459; 5,758,192; 5,760,603; 5,760,604; 5,760,607; 5,761,483; 5,764,076; 5,764,534; 5,764,564; 5,768,179; 5,770,951; 5,773,993; 5,778,439; 5,781,756; 5,784,313; 5,784,577; 5,786,240; 5,787,007; 5,789,938; 5,790,479; 5,790,882; 5,795,068; 5,796,269; 5,798,656; 5,801,546; 5,801,547; 5,801,548; 5,811,985; 5,815,004; 5,815,016; 5,815,404; 5,815,405; 5,818,255; 5,818,730; 5,821,772; 5,821,774; 5,825,202; 5,825,662; 5,825,787; 5,828,230; 5,828,231; 5,828,236; 5,828,608; 5,831,448; 5,831,460; 5,831,845; 5,831,907; 5,835,402; 5,838,167; 5,838,901; 5,838,954; 5,841,296; 5,841,867; 5,844,422; 5,844,424; 5,844,829; 5,844,844; 5,847,577; 5,847,579; 5,847,580; 5,847,993; 5,852,323; 5,861,761; 5,862,082; 5,867,396; 5,870,309; 5,870,327; 5,870,586; 5,874,834; 5,875,111; 5,877,632; 5,877,979; 5,880,492; 5,880,598; 5,880,620; 5,883,525; 5,886,538; 5,889,411; 5,889,413; 5,889,701; 5,892,681; 5,892,961; 5,894,420; 5,896,047; 5,896,329; 5,898,319; 5,898,320; 5,898,602; 5,898,618; 5,898,893; 5,907,245; 5,907,248; 5,909,125; 5,909,453; 5,910,732; 5,912,937; 5,914,514; 5,914,616; 5,920,201; 5,920,202; 5,920,223; 5,923,185; 5,923,602; 5,923,614; 5,928,338; 5,931,962; 5,933,023; 5,933,025; 5,933,369; 5,936,415; 5,936,424; 5,939,930; 5,942,913; 5,944,813; 5,945,837; 5,946,478; 5,949,690; 5,949,712; 5,949,983; 5,949,987; 5,952,839; 5,952,846; 5,955,888; 5,956,748; 5,958,026; 5,959,821; 5,959,881; 5,959,885; 5,961,576; 5,962,881; 5,963,048; 5,963,050; 5,969,539; 5,969,543; 5,970,142; 5,970,372; 5,971,595; 5,973,506; 5,978,260; 5,986,958; 5,990,704; 5,991,523; 5,991,788; 5,991,880; 5,991,908; 5,995,419; 5,995,744; 5,995,988; 5,999,014; 5,999,025; 6,002,282; and 6,002,991; Re. 34,363, Re. 34,444, and Re. 34,808. Other U.S. and foreign patents pending. Xilinx, Inc. does not represent that devices shown or products described herein are free from patent infringement or from any other third party right. Xilinx, Inc. assumes no obligation to correct any errors contained herein or to advise any user of this text of any correction if such be made. Xilinx, Inc. will not assume any liability for the accuracy or correctness of any engineering or software support or assistance provided to a user.

Xilinx products are not intended for use in life support appliances, devices, or systems. Use of a Xilinx product in such applications without the written consent of the appropriate Xilinx officer is prohibited.

Copyright 1991-2000 Xilinx, Inc. All Rights Reserved.

About This Manual

Note This Xilinx software release is certified as Year 2000 compliant.

Contents

- “[Introduction](#)” chapter describes JTAG Programmer software.
- “[Hardware](#)” chapter provides information for connecting and using the XChecker Serial Cable or the Parallel Download Cable for system operation.
- “[JTAG Programmer Tutorial](#)” chapter documents the basic tasks needed to download programming to XC9500/XL/XV family devices in-system.
- “[Designing Boundary-Scan and ISP Systems](#)” chapter documents using the JTAG Programmer with FPGA devices.
- “[Boundary Scan Basics](#)” appendix contains reference information about boundary scan basics.
- “[JTAG Parallel Cable Schematic](#)” appendix has schematics for the XChecker Cable and the Parallel Download Cable.
- “[Troubleshooting Guide](#)” appendix contains troubleshooting information.
- “[Error Messages](#)” appendix provides a list of error messages that the JTAG Programmer may report. For most error messages a workaround is suggested.

- “Using the Command Line Interface” appendix documents the basics of using the JTAG Programmer from a command line in a workstation environment.
- “Standard Methodologies for Instantiating the BSCAN Symbol” appendix contains programming examples.

Additional Resources

For additional information, go to <http://support.xilinx.com>. The following table lists some of the resources you can access from this Web site. You can also directly access these resources using the provided URLs.

| Resource | Description/URL |
|-------------------|---|
| Tutorials | Tutorials covering Xilinx design flows, from design entry to verification and debugging http://support.xilinx.com/support/techsup/tutorials/index.htm |
| Answers Database | Current listing of solution records for the Xilinx software tools Search this database using the search function at http://support.xilinx.com/support/searchtd.htm |
| Application Notes | Descriptions of device-specific design techniques and approaches http://support.xilinx.com/apps/appswb.htm |
| Data Book | Pages from <i>The Programmable Logic Data Book</i> , which contain device-specific information on Xilinx device characteristics, including readback, boundary scan, configuration, length count, and debugging http://support.xilinx.com/partinfo/databook.htm |
| Xcell Journals | Quarterly journals for Xilinx programmable logic users http://support.xilinx.com/xcell/xcell.htm |
| Technical Tips | Latest news, design tips, and patch information for the Xilinx design environment http://support.xilinx.com/support/techsup/journals/index.htm |

Conventions

This manual uses the following conventions. An example illustrates each convention.

Typographical

The following conventions are used for all documents.

- `Courier font` indicates messages, prompts, and program files that the system displays.

```
speed grade: - 100
```

- **Courier bold** indicates literal commands that you enter in a syntactical statement. However, braces “{ }” in Courier bold are not literal and square brackets “[]” in Courier bold are literal only in the case of bus specifications, such as bus [7:0].

```
rpt_del_net=
```

Courier bold also indicates commands that you select from a menu.

File → **Open**

- *Italic font* denotes the following items.
 - ◆ Variables in a syntax statement for which you must supply values

```
edif2ngd design_name
```

- ◆ References to other manuals

See the *Development System Reference Guide* for more information.

- ◆ Emphasis in text

If a wire is drawn so that it overlaps the pin of a symbol, the two nets are *not* connected.

- Square brackets “[]” indicate an optional entry or parameter. However, in bus specifications, such as bus [7:0], they are required.

```
edif2ngd [option_name] design_name
```

- Braces “{ }” enclose a list of items from which you must choose one or more.

```
lowpwr = {on|off}
```

- A vertical bar “|” separates items in a list of choices.

```
lowpwr = {on|off}
```

- A vertical ellipsis indicates repetitive material that has been omitted.

```
IOB #1: Name = QOUT'
```

```
IOB #2: Name = CLKIN'
```

```
.  
. .  
. . .
```

- A horizontal ellipsis “...” indicates that an item can be repeated one or more times.

```
allow block block_name loc1 loc2locn;
```

Online Document

The following conventions are used for online documents.

- Red-underlined text indicates an interbook link, which is a cross-reference to another book. Click the red-underlined text to open the specified cross-reference.

-
- Blue-underlined text indicates an intrabook link, which is a cross-reference within a book. Click the blue-underlined text to open the specified cross-reference.

Contents

About This Manual

| | |
|----------------------------|----|
| Contents | v |
| Additional Resources | vi |

Conventions

| | |
|-----------------------|----|
| Typographical | v |
| Online Document | vi |

Chapter 1 Introduction

| | |
|--|-----|
| Device operation options available to users are: | 1-1 |
| Non-Volatile Device Data Security | 1-2 |
| User Feedback | 1-2 |
| Required Files | 1-3 |
| JEDEC Files | 1-3 |
| BSDL Summary | 1-3 |
| BIT Files | 1-3 |
| MCS/EXO Prom Files | 1-4 |

Chapter 2 Hardware

| | |
|---|------|
| Download Cables | 2-1 |
| XChecker Hardware (Serial) | 2-2 |
| Connecting for System Operation | 2-8 |
| Cable Connections | 2-8 |
| Baud Rates | 2-10 |
| Connecting the XChecker Cable | 2-10 |
| Connecting the XChecker Cable | 2-10 |
| Connection to Your Target System | 2-10 |
| Parallel Cable | 2-11 |
| Connecting for System Operation | 2-15 |
| Configuring the Parallel Download Cable | 2-15 |

| | |
|-------------------------------------|------|
| Flying Lead Connectors | 2-16 |
| MultiLINX Cable | 2-18 |
| MultiLINX Baud Rates | 2-19 |
| MultiLINX Hardware Advantages | 2-19 |
| MultiLINX Power Requirements | 2-20 |
| MultiLINX Signals | 2-20 |
| Power Up Sequencing | 2-21 |

Chapter 3 JTAG Programmer Tutorial

| | |
|--|------|
| Cable Setup | 3-1 |
| Selecting a Port for the Cable | 3-1 |
| Creating New Chain Descriptions | 3-3 |
| Configuring a Device In-System | 3-3 |
| Define Device Manually | 3-7 |
| Programming Xilinx CPLD and FPGA Devices | 3-8 |
| Concurrent Mode | 3-9 |
| Use HIGHZ instead of BYPASS | 3-9 |
| Selecting Parts for Programming | 3-10 |
| Selecting Operations | 3-11 |
| Modifying a Chain | 3-12 |
| Adding a Device | 3-13 |
| Changing a Part | 3-13 |
| Deleting a Part | 3-13 |
| Selecting the Entire Chain | 3-13 |
| Saving the Chain Description | 3-14 |
| Debugging a Chain | 3-14 |
| Data Security Selection | 3-16 |
| Options Specific to Proms | 3-17 |
| Generating SVF Files | 3-18 |
| Substituting with Version n Devices | 3-20 |
| Using the Batch Tool (jtagprog) | 3-20 |
| Using the JTAG Programmer | 3-20 |

Chapter 4 Designing Boundary-Scan and ISP Systems

| | |
|---|-----|
| Connecting Devices in a Boundary-Scan Chain | 4-1 |
| FPGA Device Considerations | 4-2 |
| Bitstream Considerations | 4-3 |
| Virtex Considerations | 4-3 |
| Device Set-up | 4-3 |
| Verifying Device Configuration | 4-4 |
| Device Behavior Notes | 4-4 |

Appendix A Boundary Scan Basics

| | |
|--|-----|
| Boundary Scan/IEEE Standard 1149.1 | A-1 |
| What can it be used for? | A-1 |
| How does it work? | A-2 |
| The TAP Controller | A-2 |
| The Instruction Register | A-2 |
| The Data Registers | A-2 |
| JTAG Test Access Port | A-2 |
| JTAG TAP Controller | A-3 |
| JTAG TAP Controller States | A-3 |
| JTAG Instructions Supported in FastFLASH Parts | A-5 |
| Mandatory Boundary Scan Instructions | A-5 |
| Optional Boundary Scan Instructions | A-5 |
| FastFLASH Reconfiguration Instructions | A-6 |

Appendix B JTAG Parallel Cable Schematic

Appendix C Troubleshooting Guide

| | |
|----------------------------------|-----|
| Communication | C-1 |
| Improper Connections | C-2 |
| Improper or Unstable VCC | C-3 |
| Boundary Scan Chain Errors | C-4 |
| System Noise | C-6 |

Appendix D Error Messages

| | |
|----------------------|-----|
| Error Messages | D-1 |
|----------------------|-----|

Appendix E Using the Command Line Interface

| | |
|--|-----|
| Using JTAG Programmer Batch Version Software | E-1 |
| JTAG Programmer Files | E-2 |
| Invoking JTAG Programmer | E-2 |
| Downloading | E-2 |
| Verifying | E-3 |
| Command-Line Options | E-4 |
| Interactive Mode Commands | E-5 |
| Autoconfigure — Identify Chain Composition | E-6 |
| Batch — Execute in Batch Mode | E-6 |
| Baud — Specify Baud Rate | E-6 |
| Dump | E-7 |
| Erase | E-7 |
| Exit — Terminate Session | E-7 |
| Functest | E-8 |

| | |
|---|------|
| Help — Online Help | E-8 |
| Id_loop — Idcode Looping | E-8 |
| Opgroup — Setup Group for Concurrent Operations | E-8 |
| Part — Specify Device Chain | E-9 |
| Partinfo | E-9 |
| Port — Specify Download/Readback Port | E-10 |
| Program | E-10 |
| Quit — Terminate Session | E-11 |
| Save — Save Option Settings | E-11 |
| Settings — Display Settings | E-12 |
| Sys — Temporarily Exit to Operating System | E-12 |
| Verify — Verify Target CPLD Bitstream | E-12 |

Appendix F Standard Methodologies for Instantiating the BSCAN Symbol

| | |
|---|------|
| Instantiating the BSCAN symbol in Foundation XVHDL | F-1 |
| Solution 1 - XC5200 Family | F-1 |
| Solution 2 - XC4000 Family | F-3 |
| Instantiating the BSCAN symbol in Synplicity | F-5 |
| Solution 1 - XC5200 Family - Verilog Code | F-5 |
| Solution 2: Using the Synplicity Xilinx Macro Library | F-7 |
| Solution 3: XC4000 Devices - Verilog Code | F-7 |
| Solution 4: XC4000 Devices - VHDL Code | F-8 |
| Solution 5: XC5200 Devices - VHDL Code | F-11 |
| Instantiating the BSCAN symbol in Synopsys | F-14 |
| Solution 1: XC5200 Devices - VHDL Code | F-14 |
| Solution 2: XC4000 Devices - Verilog Code | F-17 |
| Solution 3: XC5200 Devices - Verilog Code | F-18 |
| Solution 4: XC4000 Devices - VHDL Code | F-20 |

Introduction

This chapter introduces you to the basic concepts of Xilinx JTAG capabilities and Xilinx in-system programmable products. You can use JTAG Programmer to download, read back and verify design configuration data, to perform functional tests on any device, and to probe internal logic states of a Xilinx XC9500, XC9500XL, XC9500XV, Spartan or Virtex design. This chapter contains the following sections:

- [Device operation options available to users are:](#)
- [Required Files](#)

JTAG Programmer software uses sequences of JTAG instructions to perform the following programming and verification operations. The user need only select the desired operation; the software will execute all required JTAG commands transparently. For a description of JTAG instructions supported by Xilinx devices, see Appendix A.

Device operation options available to users are:

Program. Downloads the contents of the JEDEC, BIT or Prom file to the device programming registers.

Verify. Reads back the contents of the device programming registers and compares them with the JEDEC, BIT or Prom file.

Erase. Clears device configuration information.

Functional Test. Applies user-specified functional vectors from the JEDEC file to the device using the JTAG INTEST instruction, comparing results obtained against expected values. Reports any differences to the user.

Blank Check. Checks whether a device has been programmed or is erased.

Readback Jedec. Reads back the contents of device programming registers and creates a new JEDEC/Prom file with the results.

Get Device ID. Reads the contents of the JTAG IDCODE register. Displays contents for the user.

Get Device Checksum. Reads back the contents of device programming registers and calculates a checksum for comparison against the expected value.

Get Device Signature/Usercode. This value is selected by the user during fitting. The specified value is translated to binary values in the JEDEC file. During device programming these values are loaded into the JTAG USERCODE register. This function reads the contents of the USERCODE register and displays the result. For XC1800 Proms, 8 digit hex usercode can be specified at program time.

Bypass. Ignores this device when addressing devices in the JTAG boundary scan chain. This option is only available through chain operations.

Non-Volatile Device Data Security

Any Xilinx XC9500/XL/XV device selected for programming can be secured with the Write Protect or Read Protect or both.

When enabled, Read Protect disables reading the programmed contents of a device (the IDCODE and USERCODE registers remain readable).

Write Protect allows only the reading of the programmed data. The device contents cannot be altered or re-programmed.

When both Read Protect and Write Protect are enabled, the device can be neither read nor re-programmed.

Security options do not affect the accessibility of the bypass or boundary-scan register.

User Feedback

When using the graphical user interface, immediate feedback is provided by a scrolling log file and alert boxes. Detailed information regarding failure is located in the system log file, and is provided for both the PC and workstation based tool.

Required Files

You need to provide JEDEC files for each XC9500/XL/XV CPLD device, BIT files for each Xilinx FPGA device (Virtex or Spartan) in the JTAG programming chain, and BSDL files for the remaining devices.

JEDEC Files

JEDEC files are XC9500/XL/XV CPLD programming files generated by the Xilinx fitter. They are ASCII text files containing programming information and, optionally, functional test vectors that can be used to verify the correct functional behavior of the programmed device. One JEDEC file is required for each XC9500/XL/XV device in the JTAG programming chain.

Use the device properties (File → Properties) dialog to specify the location of JEDEC files for each XC9500/XL/XV device. The name of the JEDEC file is assumed to be <design name>.jed, but can be specified exactly by the user.

BSDL Summary

The Boundary-Scan Description Language (BSDL) files use a subset of VHDL to describe the boundary scan features of a device. The JTAG Programmer automatically extracts the length of the instruction register from the BSDL file to place non-XC9500/XL/XV devices in bypass mode. XC9500/XL/XV BSDL files are located automatically by the JTAG Programmer.

Use the device properties dialog to specify the location of BSDL files for non-XC9500/XL/XV devices. The name of the BSDL file is assumed to be <device name>.bsd.

BIT Files

Bit files are Xilinx FPGA configuration files generated by the Xilinx FPGA design software. They are proprietary format binary files containing configuration information. One BIT file is required for each Xilinx FPGA in the JTAG boundary-scan chain.

Use the device properties (File → Properties) dialog to specify the location of the BIT files for each Xilinx FPGA device. The required extension for BIT files is .bit.

MCS/EXO Prom Files

Prom files are prom programming files generated by the prom file formatter. They are ASCII text files used to specify configuration data. One Prom file is required for each Xilinx prom in the JTAG boundary scan chain. Use the device properties (File → Properties) dialog to specify the location of the MCS/EXO files for each Xilinx prom. The required extension for MCS and EXO files is .mcs and .exo respectively.

Hardware

This chapter gives specific information about using cables to download from the JTAG Programmer to devices in-system.

This chapter contains the following sections:

- [Download Cables](#)
- [“XChecker Hardware \(Serial\)”](#)
- [“Parallel Cable”](#)
- [“MultiLINX Cable”](#)
- [Power Up Sequencing](#)

Download Cables

There are three cables available for use with the JTAG Programmer. The first is an RS232 serial cable known as the XChecker Cable. The second is the Parallel Download Cable which can be connected to a PC's parallel printer port. The third is the MultiLINX cable which can be connected to a USB port (Windows 98 only) or serial port.

There are a few advantages to be considered in selecting a cable:

- The XChecker Cable or Multilinx Cable connects to the serial port of both workstations and PCs.
- The Parallel Cable has better drive capability. The Parallel Cable can drive up to 10 XC9500/XL/XV devices in a boundary-scan chain, and the XChecker Cable can drive up to 4 XC9500/XL/XV devices.
- The Parallel Cable is at least 5 times faster.

If you have a Parallel Download Cable proceed to Parallel Cable.

If you have a MultiLINX Cable proceed to MultiLINX Cable.

XChecker Hardware (Serial)

The XChecker hardware consists of a cable assembly with internal logic, a test fixture, and a set of headers to connect the cable to your target system.

Using the XChecker hardware requires either a standard DB-9 or DB-25 RS-232 serial port. If you have a different serial port connection, you need to provide the appropriate adapter. “XChecker Hardware and Accessories” shows the XChecker cable hardware and accessories.

The XChecker cable can be used with a single CPLD or several devices connected in a boundary-scan chain to download and read-back configuration and boundary-scan data.

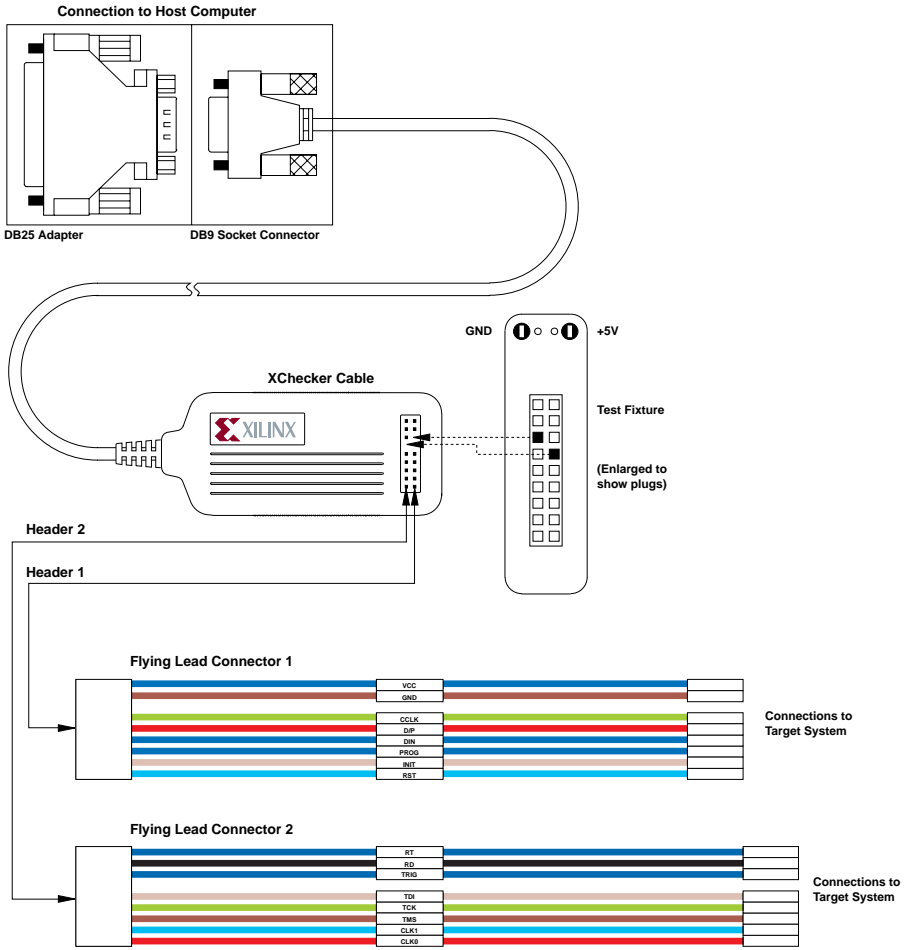

X7248

Figure 2-1 XChecker Hardware and Accessories

XChecker Cable

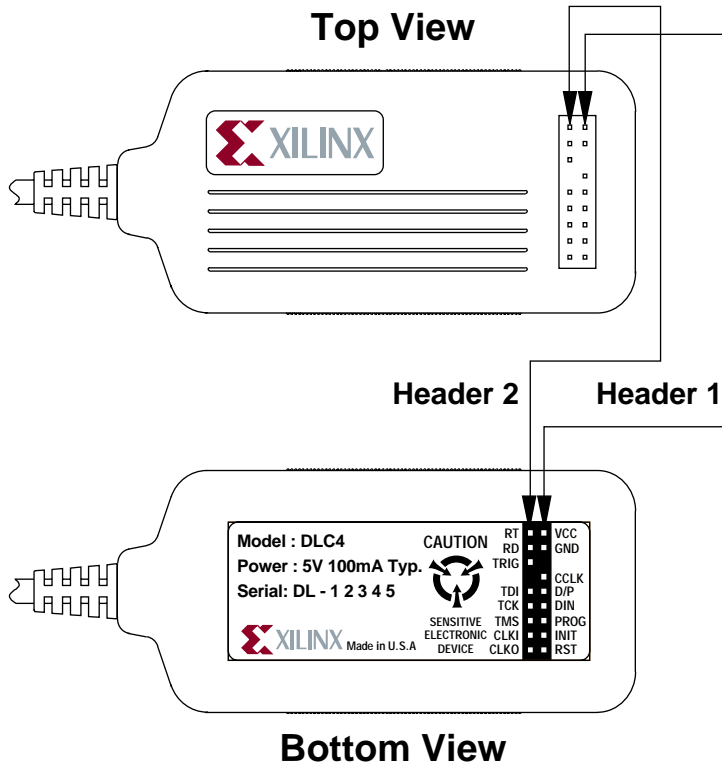

X7249

Figure 2-2 XChecker Cable

Connecting for System Operation

Connect the XChecker cable to the host system and your target system as shown in “XChecker Connections to JTAG Boundary-scan TAP”.

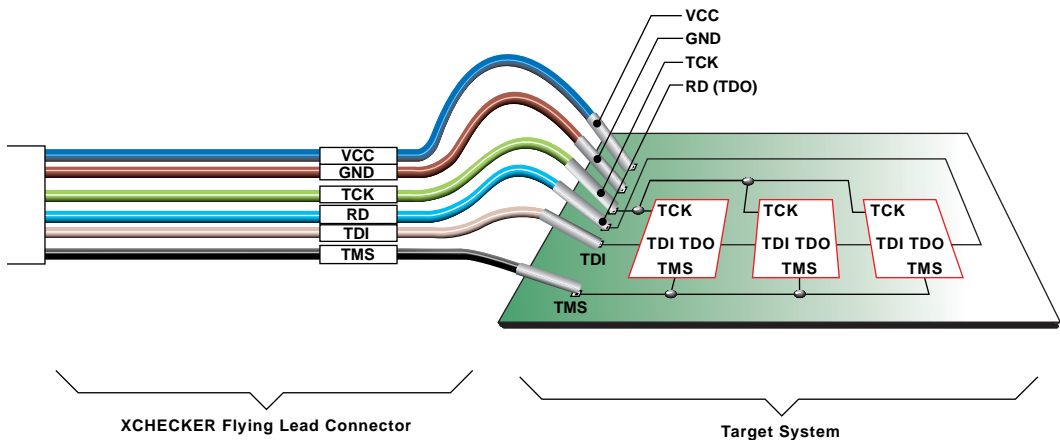

X7976

Figure 2-3 XChecker Connections to JTAG Boundary-scan TAP

Cable Connections

Connections between the cable assembly and the target system use only 6 of the sixteen leads. For connection to JTAG boundary-scan systems you need only ensure that the VCC, GND, TDI, TCK, TMS and RD (TDO) pins are connected.

Once installed properly, the connectors provide power to the cable, allow download and readback of configuration data, and provide for logic probe of device pins.

“XChecker Cable Connections and Definitions” table describes the pin connections to the target circuit board

Table 2-1 XChecker Cable Connections and Definitions

| Name | Function | Connections |
|-------------|--|----------------------------|
| VCC | Power – Supplies VCC (5 V, 100 mA, typically) to the cable. Use adapter HW-XCH3V for 3V devices. | To target system VCC |
| GND | Ground – Supplies ground reference to the cable. | To target system ground |
| RD (TDO) | Read Data – Read back data from the target system is read at this pin. | Connect to system TDO pin. |
| TDI | Test Data In – this signal is used to transmit serial test instructions and data. | Connect to system TDI pin. |
| TCK | Test Clock – this clock drives the test logic for all devices on boundary-scan chain. | Connect to system TCK pin. |
| TMS | Test Mode Select – this signal is decoded by the TAP controller to control test operations. | Connect to system TMS pin. |
| CLKI | Not used. | Unconnected. |
| CLKO | Not used. | Unconnected. |
| CCLK | Not used. | Unconnected. |
| D/P | Not used. | Unconnected. |
| DIN | Not used. | Unconnected. |
| PROG | Not used. | Unconnected. |
| INIT | Not used. | Unconnected. |
| RST | Not used. | Unconnected. |
| RT | Not used. | Unconnected. |
| TRIG | Not used. | Unconnected. |

Baud Rates

The XChecker Cable supports Baud rates as shown in Table 2-2.

Table 2-2 Valid Baud Rates

| Platform | 9600 | 19200 | 38400 |
|----------|------|-------|-------|
| IBM PC | X | X | X |
| SUN | X | X | X |
| HP 700 | X | X | X |

Connecting the XChecker Cable

There are two simple steps for connecting the cable:

- [Connecting the XChecker Cable](#)
- [Connection to Your Target System](#)

Connecting the XChecker Cable

The XChecker cable connects to your system RS-232 serial port. You may need a DB-9/DB-25 adapter, which accommodates most serial ports, so that you can connect the XChecker cable to your host system.

1. The JTAG Programmer software will automatically identify the XChecker cable when correctly connected to your computer. If you choose to, you may also select this connection manually. To set up a serial port manually:

Output → Cable Setup

2. Select XChecker, then click on OK. If you are using the XChecker Cable you may also select a BAUD rate. see [Table 2-2](#).

Connection to Your Target System

The following steps insure proper connection to your target system.

1. You need appropriate pins on the target system for connecting the target system board to the header connection on the cable. These connectors must be standard 0.025-inch square male pins that have dedicated traces to the target system control pins. You connect to these pins with the flying lead connectors.

2. The XChecker cable draws its power from the target system through VCC and GND. Therefore, power to XChecker, as well as to the target system, must be stable. Do not connect any signals before connecting VCC and ground.
3. If you are connecting the XChecker Vcc to a 3V system, you will need an adapter. Xilinx carries an adapter, part number HW-XCH3V.
4. If your system's power is turned off before or during JTAG Programmer operations, the cable will not operate. Your system's power should be on during JTAG Programming operations.
5. If the power has been momentarily interrupted, go to Output → Cable Reset to reinitialize the XChecker cable. If you do not want to operate at maximum Baud rate, go to the Cable Communication Setup dialog box (Output → Cable Setup...) and set a lower rate.

Parallel Cable

The Parallel Download Cable consists of a cable assembly containing logic to protect your PC's parallel port and a set of headers to connect to your target system.

Using the Parallel Download Cable requires a PC equipped with an AT compatible parallel port interface with a DB25 standard printer connector. Figure 2-4 shows the Parallel Download Cable.

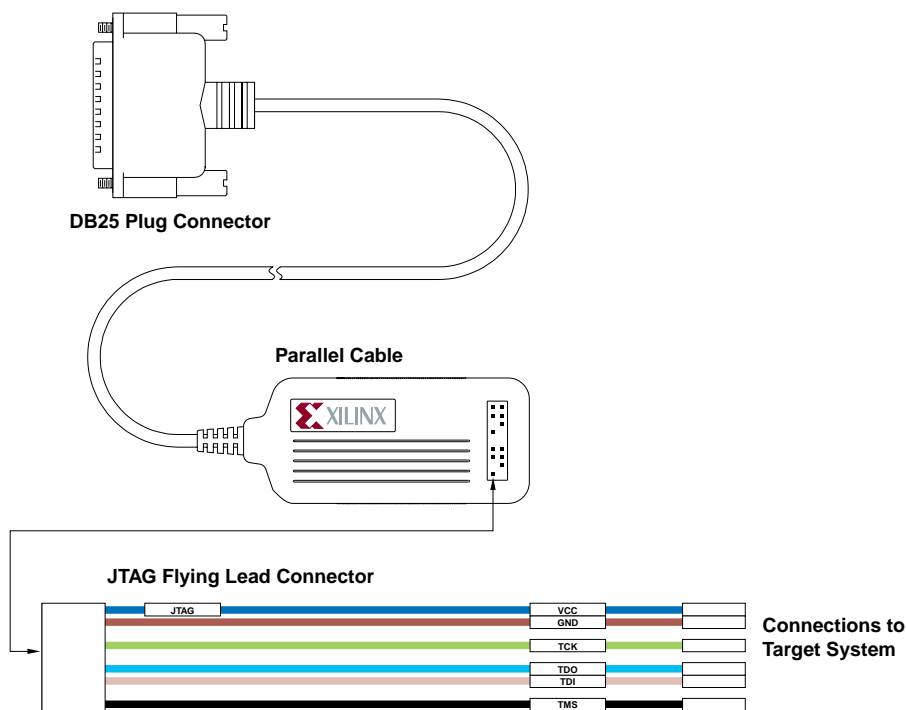

X7251

Figure 2-4 Parallel Download Cable and Accessories

The cable assembly contains logic designed to electrically isolate the target system from the parallel port of your PC host system.

The parallel download cable can be used with a single CPLD or several connected in a boundary-scan chain to download and read-back configuration and boundary-scan data.

The transmission speed of the Parallel Download Cable is determined solely by the speed at which the host PC can transmit data through its parallel port interface.

Figure 2-5 shows top and bottom view of the Parallel Download Cable.

Parallel Cable

Top View

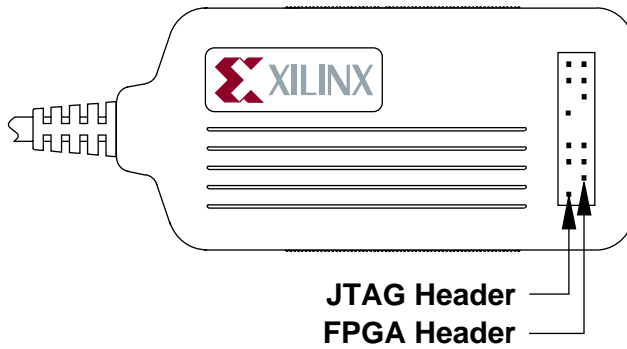

Bottom View

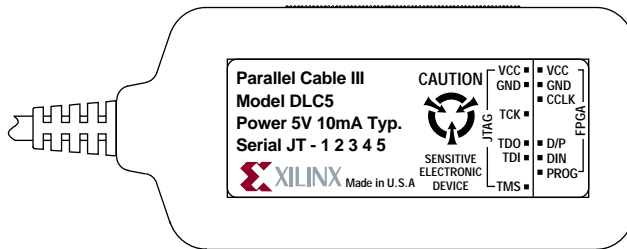

X7252

Figure 2-5 Top and Bottom View of Parallel Download Cable

Connecting for System Operation

Connect the parallel cable to the host system and your target system as shown in [Figure 2-6](#).

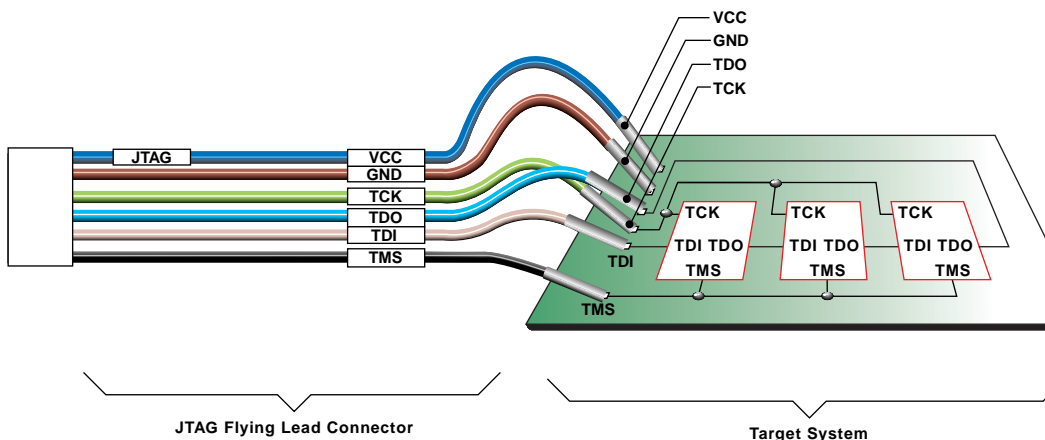

x

Figure 2-6 Parallel Download Cable Connection to JTAG Boundary-scan TAP

“[JTAG Parallel Cable Schematic](#)” appendix contains schematic diagrams of the Parallel Download Cable.

Configuring the Parallel Download Cable

To configure your parallel download cable, follow these steps:

1. On PCs you can connect the parallel cable to your system’s parallel printer port. The JTAG Programmer software will automatically identify the cable when correctly connected to your PC. If you choose to, you may also select this connection manually. To set up a parallel port manually:

Output → Cable Setup

2. Select the Parallel box and match to the port you are using, then click on OK.

Flying Lead Connectors

The flying lead connector has a 9-pin (6 signals, 3 keys) header connector that fits onto the cable's JTAG header. The pin order is listed in [Table 2-3](#). These header connectors are keyed to assure proper orientation to the cable assembly.

The flying lead connector has six individual female connectors on one end that fit onto standard 0.025" square male pins. Each lead is labeled to identify the proper pin connection.

When you layout the printed circuit board for use with JTAG in-system programming and testing, a few adjustments will make the process of connecting and downloading easier.

- Provide pins on your printed circuit board for VCC, GND, TCK, TDO, TDI and TMS.
- These pins must be standard 0.025" square male pins that have dedicated traces to the target system control pins. You connect to these pins with the flying lead connector.
- Place pins on board so that flying leads can reach them. The length of our flying leads is six inches. While pins may be a couple inches apart, do not have any two JTAG pins more than six inches apart.
- Keep header pins on your board a minimum of 0.10" apart.

Table 2-3 Parallel Cable Connections and Definitions

| Name | Function | Connections |
|------|---|----------------------------|
| VCC | Power – Supplies VCC (5 V, 3.3V, or 2.5V, 10 mA, typically) to the cable. | To target system VCC |
| GND | Ground – Supplies ground reference to the cable. | To target system ground |
| TCK | Test Clock – this clock drives the test logic for all devices on boundary-scan chain. | Connect to system TCK pin. |

Table 2-3 Parallel Cable Connections and Definitions

| Name | Function | Connections |
|-------------|---|----------------------------|
| TDO | Read Data – Read back data from the target system is read at this pin. | Connect to system TDO pin. |
| TDI | Test Data In – this signal is used to transmit serial test instructions and data. | Connect to system TDI pin. |
| TMS | Test Mode Select – this signal is decoded by the TAP controller to control test operations. | Connect to system TMS pin. |

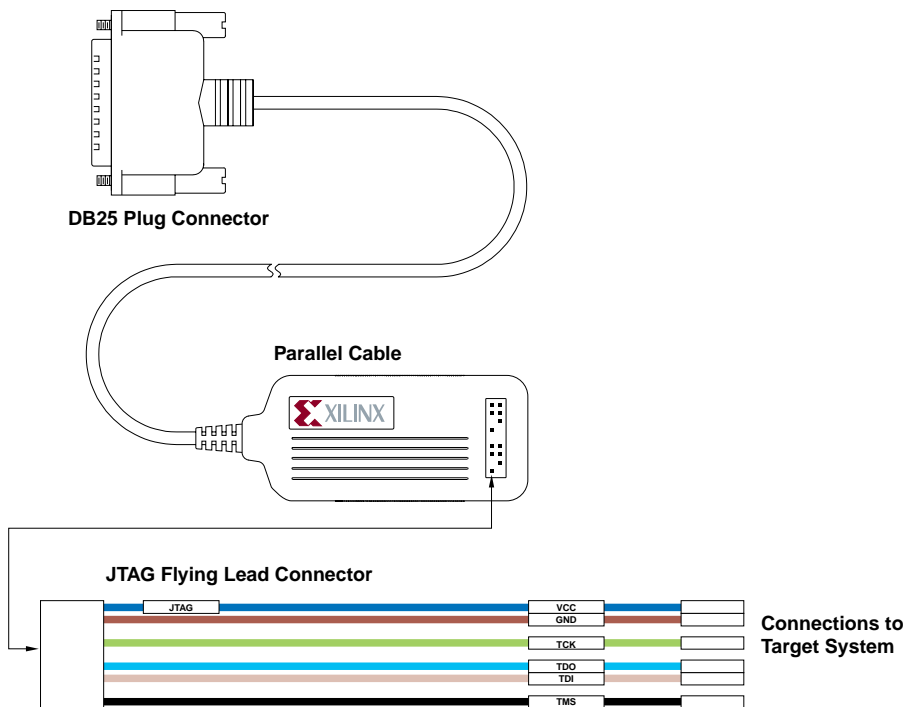

X7251

Figure 2-7 JTAG Cable and Leads (parallel cable shown)

MultiLINX Cable

You can use the MultiLINX Cable to download and verify. The MultiLINX Cable hardware communicates with the host over the Universal Serial Bus (USB) at up to 12M bits/sec, or at variable baud rates over an RS-232 interface at up to 57600 bits/sec.

The MultiLINX Cable should be compatible in supporting Readback & Verify for all the FPGAs supported by the XChecker Cable. In addition to the supported devices, the MultiLINX Cable will support the

devices that were not supported by the XChecker Cable since the MultiLINX Cable has no RAM size limitations. These devices include those devices in 4000E, 4000XL, and SPARTAN whose bitfile size is more than 256K bits. The MultiLINX Cable will also support Read-back & Verify functions in the new Virtex family.

You can access the following mentioned application notes with descriptions of device-specific design techniques and approaches from the support page at (<http://support.xilinx.com/support/searchtd.htm>).

“Getting Started with MultiLINX Guide” application note is a quick reference to everything you need to know to use the MultiLINX Cable; using a USB device, Mixed Voltage environments, connections for all the supported Modes.

“Integrating MultiLINX Cable with Target System Design” application note describes how to setup a Prototype application for use with the MultiLINX Cable.

“Xilinx Cable Overview and Roadmap” application note describes all the cables, their capabilities, and associated software tools.

MultiLINX Baud Rates

Communication between the host system and the MultiLINX Cable is dependent on host system capability. The following table lists the valid baud rates for the supported platforms.

Table 2-4 Valid Baud Rates

| Baud Rates | | |
|--------------------------|--|--|
| PC | Cable | WorkStation |
| MultiLINX Cable (USB) | 1M-12M (Currently USB is supported only on Win98/95C.) | USB is currently not supported on the WorkStation. |
| MultiLINX Cable (RS-232) | 9600, 19200, 38400, and 57600 | 9600, 19200, and 38400 |

MultiLINX Hardware Advantages

The MultiLINX cable has the following advantages:

- Fast download, readback and debug using the USB port up to 12M bits/sec.
- More configuration modes are supported.
- Supports both RS-232 ports and USB ports.
- Compatible with the currently supported devices for Readback & Verify.
- Supports new devices that are not supported by XChecker due to RAM size limitation.
- Works at low voltages (3.3V).
- Supports both Slave Serial and SelectMAP configuration modes.

MultiLINX Power Requirements

The MultiLINX Cable gets its power from the User's circuit board. The cable power does not come from the USB port (nor the RS-232 port). The red (PWR) and black (GND) wires from Flying Wire Set #1 are connected to the VCC (red wire) and Ground (black wire) lines of the circuit board that is powering the Xilinx device.

The minimum input voltage to the cable is 2.5 V (.8 A). The maximum input voltage is 5 V (.4 A).

MultiLINX Signals

The MultiLINX Cable uses the following pin connections for use in JTAG programming:

| Name | Function | Connections |
|------|---|----------------------------|
| VCC | Power – Supplies VCC (5 V, 3.3V, or 2.5V, 10 mA, typically) to the cable. | To target system VCC |
| GND | Ground – Supplies ground reference to the cable. | To target system ground |
| TCK | Test Clock – this clock drives the test logic for all devices on boundary-scan chain. | Connect to system TCK pin. |

| Name | Function | Connections |
|----------|---|----------------------------|
| RD (TDO) | Read Data – Read back data from the target system is read at this pin. | Connect to system TDO pin. |
| TDI | Test Data In – this signal is used to transmit serial test instructions and data. | Connect to system TDI pin. |
| TMS | Test Mode Select – this signal is decoded by the TAP controller to control test operations. | Connect to system TMS pin. |

Power Up Sequencing

The following considerations should be followed when powering up the JTAG Programmer.

1. Connect your cable to your host computer.
2. Turn the power to your target system off, if possible.
3. The power for the drivers is derived from the target system. Connect the cable's GND wire to the corresponding signal on the target board. Next, connect VCC to the corresponding signal on the target board.
4. Download cables will not operate if the target system's power is turned off before or during JTAG Programmer operations. Make certain that this power connection is on and stable. Your system's power should be on during JTAG Programmer operations.
5. JTAG Programmer will always initiate operations using a JTAG TAP controlled reset sequence. This performs the exact same operation as the assertion of the TRST pin; it initializes all devices' JTAG state machines and internal registers.
6. Next connect the JTAG TAP inputs. Connect TCK, TDI, TMS and TDO to the target board. TRST is not supported by the XC9500/XL/XV JTAG Download Cables. If any of your JTAG parts have a TRST pin, it should be connected to VCC.
7. Power up the target system.

8. Cable protection ensures that the parallel port cannot be damaged through normal cable operation. For increased safety, please check that the power to the system controller is on before the target system is powered up.

JTAG Programmer Tutorial

This chapter will take you through the basic steps involved in programming Xilinx devices in-system using the JTAG Programmer graphical user interface. This chapter contains the following sections:

- [Cable Setup](#)
- [Selecting a Port for the Cable](#)
- [Creating New Chain Descriptions](#)
- [Configuring a Device In-System](#)
- [Options Specific to Proms](#)
- [Generating SVF Files](#)

Cable Setup

To setup your system to download configurations in-system you must first connect the JTAG Programmer parallel download, Multi-LINX, or the XChecker cable. Cable setups and power sequencing are described in chapter 2, Hardware.

Selecting a Port for the Cable

Note If you do not want to use a cable, select SVF Output and skip this section.

1. You may select a serial or parallel port for your cable from the JTAG Programmer Interface. To set up a port:
Output → Cable Setup
2. The Cable Communication Setup dialog box will appear.

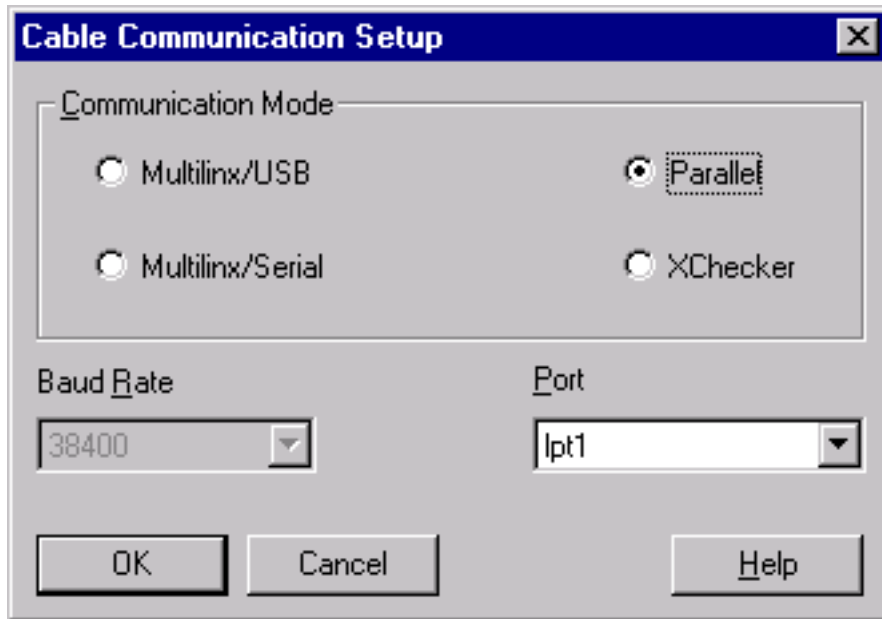

Figure 3-1 Communications Dialog Box

3. Select the cable you are using and match to the port you are using, then click on OK. If you are using the XChecker Cable or the MultiLINX cable on the serial port you may also select a BAUD rate. See Table 2-2, Valid Baud Rates.
4. Alternatively, you may use the Output → Cable Auto Connect to allow the software to automatically identify and connect to whichever download cable is installed.
5. Upon selecting any device operation, the JTAG Programmer will automatically connect to whichever cable is installed and powered up, with the following priority: Parallel, MultiLINX, XChecker.
6. If you accidentally or purposely power down your system while running JTAG Programmer, remember to select Output → Cable Reset to reinitialize the cable after re-applying power.

Creating New Chain Descriptions

A Chain Description File (CDF) is a file that contains all the information needed by the JTAG Programmer to download your designs to devices in a JTAG chain in-system.

The device chain U1, U2, ... Un is a serial chain where U1 is the first device TDI enters and Un is the last device. Un must deliver the TDO (labelled RD on the XChecker and MultiLINX cables) signal back to the cable. TMS and TCK signals enter all devices in parallel.

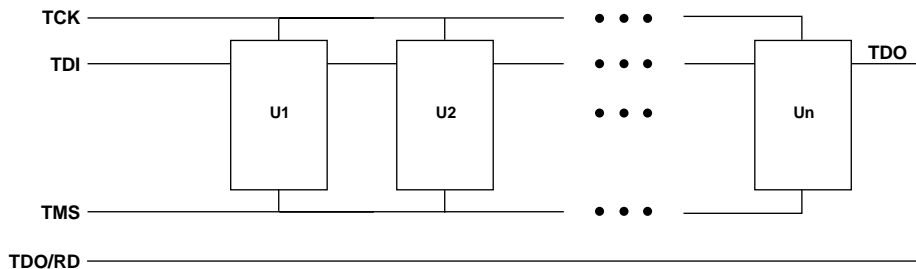

X8006

Figure 3-2 Device Chain

The chain description must contain all devices in the order that they appear in the JTAG programming chain.

Alternatively, you can use the Initialize Chain operation to automatically identify the devices in the system boundary-scan chain. You must then associate JEDEC files for XC9500/XL/XV CPLD devices, BIT files for Xilinx FPGA devices, MCS, HEX or EXO files for Xilinx Prom devices. Use BSDL files or specify the instruction register level for all other devices by using the device properties dialog box.

Configuring a Device In-System

If you have created programming files (.jed, .bit, .exo, .hex, or .mcs) and are ready to download them to Xilinx devices in-system through the JTAG chain, proceed as follows:

Note You will need a bitstream/configuration file to continue. If you have not yet generated a bitstream, please refer to the Implementation Tools tutorial.

1. Make sure the cable is attached properly and the target board is turned on.
2. Invoke the JTAG Programmer Download Software menu by double-clicking the JTAG Programmer Download Software icon.



Figure 3-3 JTAG Programmer Icon

The JTAG Programmer will appear.

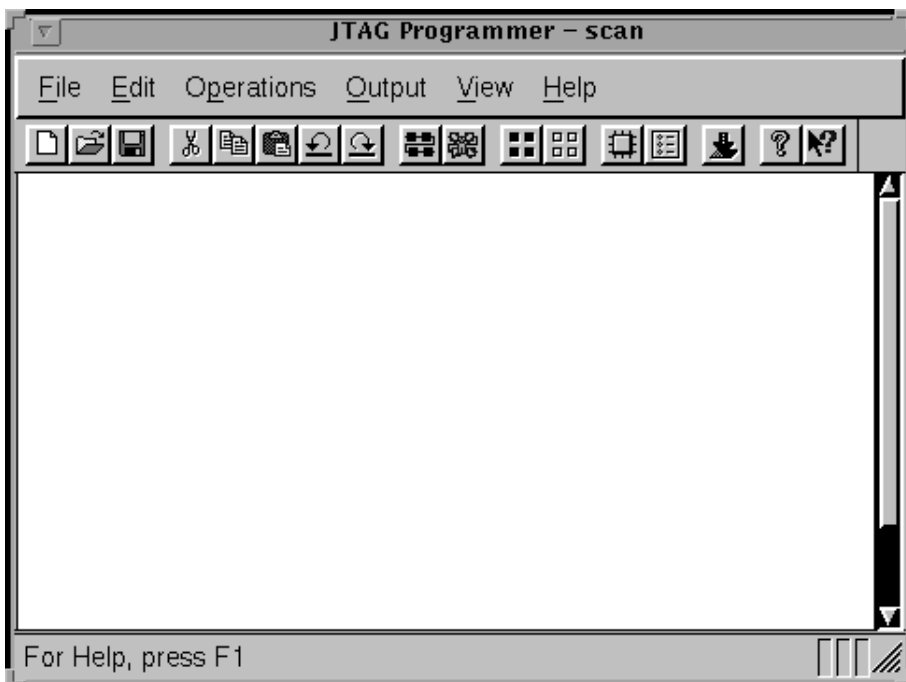

Figure 3-4 JTAG Programmer

3. Add a device for each part in your boundary-scan chain.

Edit → Add Device

Or, if you have the cable set up and connected to a boundary-scan chain, you can use the automatic device identification feature of the JTAG Programmer to display the entire chain. To do this:

File → Initialize Chain

The programmer goes out and finds all the parts in the chain, identifies them, and displays them in the JTAG Programmer. If the programmer finds a device it can't identify, it displays the device as an unknown part and asks if you have a BSDL, BIT or JEDEC file or not.

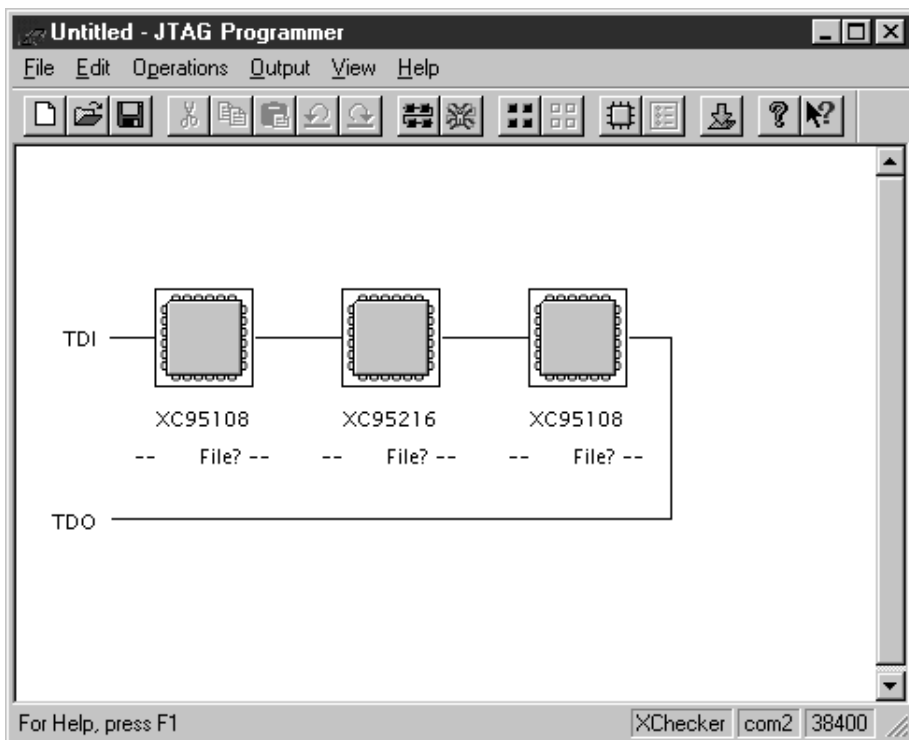

Figure 3-5 Automatic Device Identification

4. You need to specify a JEDEC file for each XC9500/XL/XV device in the boundary-scan chain, a BIT file for each Xilinx FPGA device, an MCS, HEX, or EXO file for each Xilinx Prom device,

and a BSDL file or appropriate template information for all other devices in the boundary-scan chain. Highlight the first device in the chain by clicking once on it and then select the JEDEC, BIT, EXO, HEX, MCS or BSDL file corresponding to the device.

Edit → Properties

Alternatively, you may double-click on the device icon.

The Device Properties dialog box appears

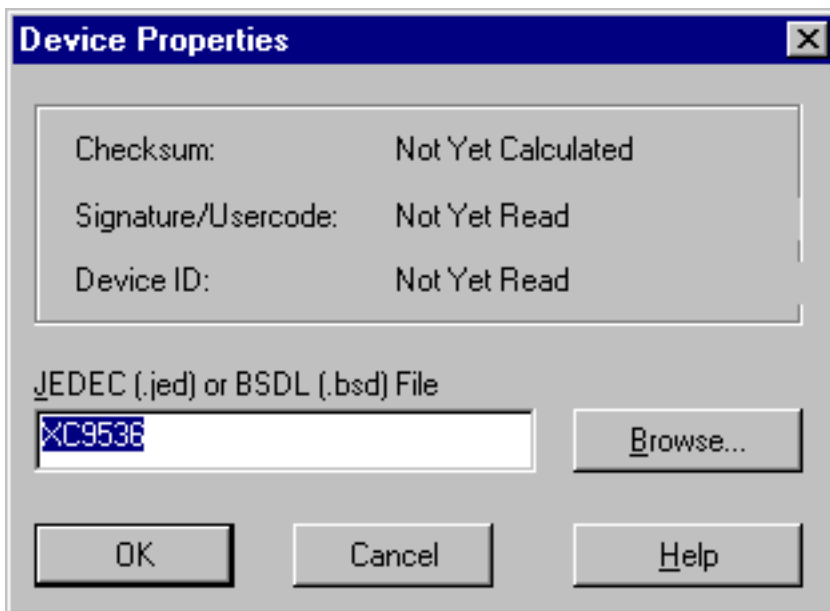

Figure 3-6 Device Properties

5. Type in the path name or click once on the browse key and find the appropriate file to assign to the highlighted part. Select JEDEC files for each XC9500/XL/XV device in the chain, MCS, HEX or EXO files for each Xilinx Prom device, BIT files for each Xilinx FPGA device, and BSDL files for the remaining devices. Repeat for each device in the chain.

For an XC1800 prom, click OK after selecting the file. The programmer will display a list of available prom files (which will be larger than the configuration data). Select the desired part and click OK. This will complete the part selection.

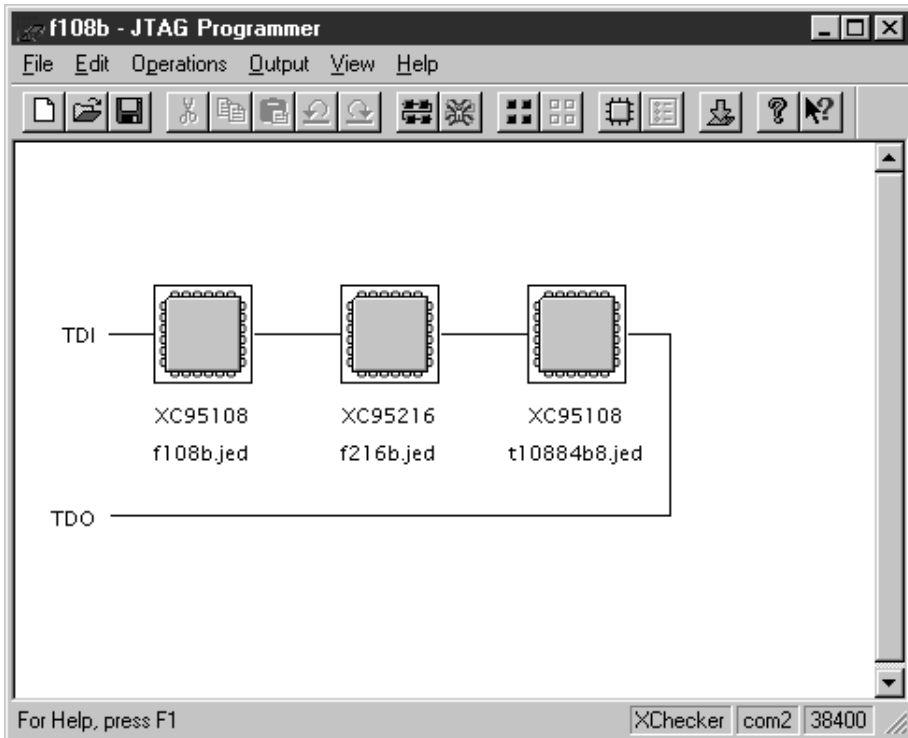

Figure 3-7 Device Chain (unprogrammed)

Define Device Manually

You can manually define a device using the Define Device dialog box. This box allows you to define the following:

- **Instruction Register Length:** The length of the IEEE 1149.1 instruction register. This is the minimum information needed to satisfy IEEE 1149.1 compliant devices.
- **JTAG Idcode (hex):** Not yet implemented.
- **HighZ Instruction (binary):** Not yet implemented.
- **Device Name:** Set the name for the device.

To access the Define Device dialog click File → Define Device. The following dialog will appear:

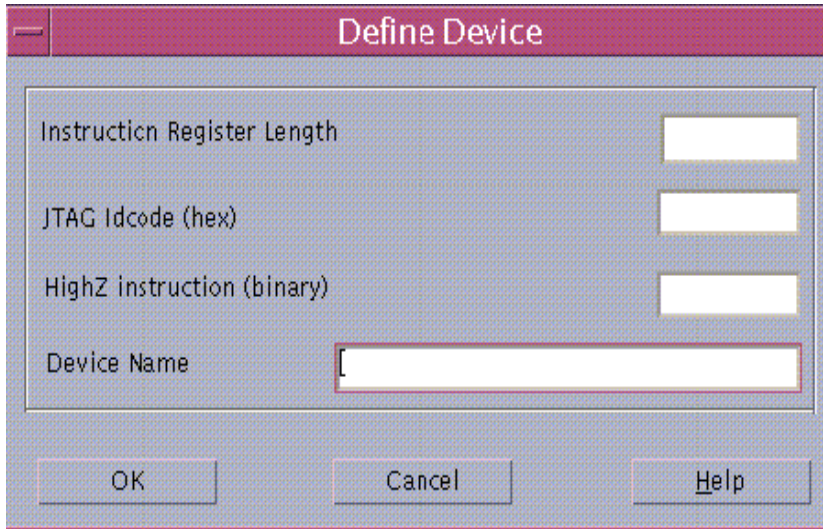

Figure 3-8 Define Device Dialog Box

Programming Xilinx CPLD and FPGA Devices

There are two preferences available that you may want to select before initiating a session. They are Concurrent Mode and Use HIGHZ instead of BYPASS. These options are selected as follows:

File → Preferences

The Preferences dialog box will appear.

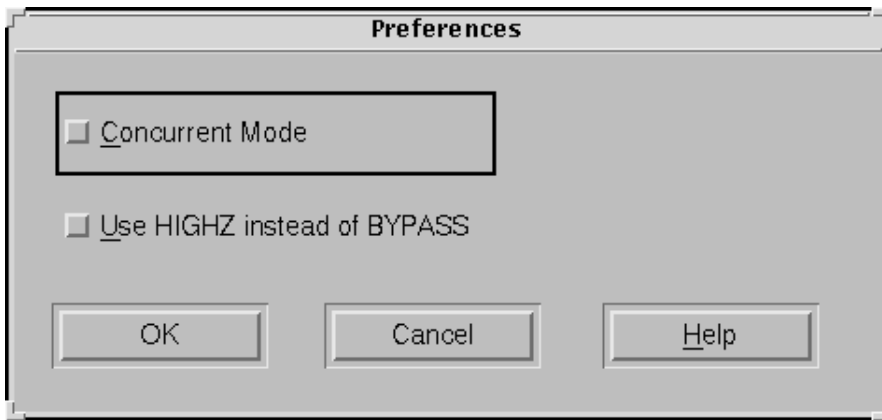

Figure 3-9 Preferences

Concurrent Mode

The JTAG Programmer normally uses a sequential methodology when accessing Xilinx CPLDs for ISP operations. It selects a device to program and sets all other devices in the boundary-scan chain into BYPASS mode. Concurrent Mode erases, programs and verifies selected devices in the chain without placing these parts in BYPASS mode. This has the advantage of saving time by executing operations simultaneously.

For example, it takes few seconds to completely erase all the sectors of a device. If you have several devices in a chain, these erase times can add up. In concurrent mode the erasures can take place simultaneously, saving time.

Concurrent mode is applicable only to Xilinx CPLD devices. Since Xilinx FPGA devices are SRAM based; their access method precludes this kind of operation.

Use HIGHZ instead of BYPASS

The JTAG Programmer usually places parts in BYPASS mode when other devices in the boundary-scan chain are being programmed. This option places XC9500/XL/XV, Spartan-II and Virtex devices in high impedance mode instead. If you suspect that noise is degrading the integrity of ISP operations, use this mode to reduce the signal activity level in the system.

If you decide to use HIGHZ instead of BYPASS you must be certain that your design can tolerate XC9500/XL/XV or Virtex device pins floating. If these pins connect to memory enable pins, for instance, their floating values may inadvertently cause the devices to turn on, potentially damaging their drivers or parts downstream from them.

Selecting Parts for Programming

If your boundary-scan chain consists of all Xilinx devices (FPGA, CPLD and SPROM), then you can select all devices at once.

1. Use Edit → Select All, or highlight each device individually, then:
 1. Operations → Program
 2. The program options box appears. Select the desired programming options, then click OK.

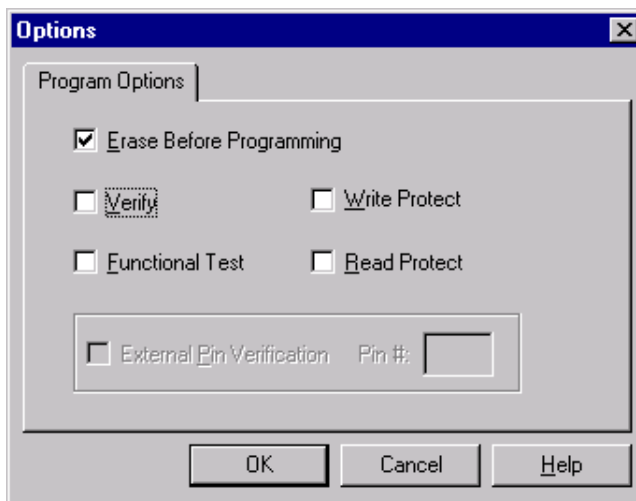

Figure 3-10 Options

3. When the programming operation is complete, the programming status of each Xilinx programmable device is reported as shown:

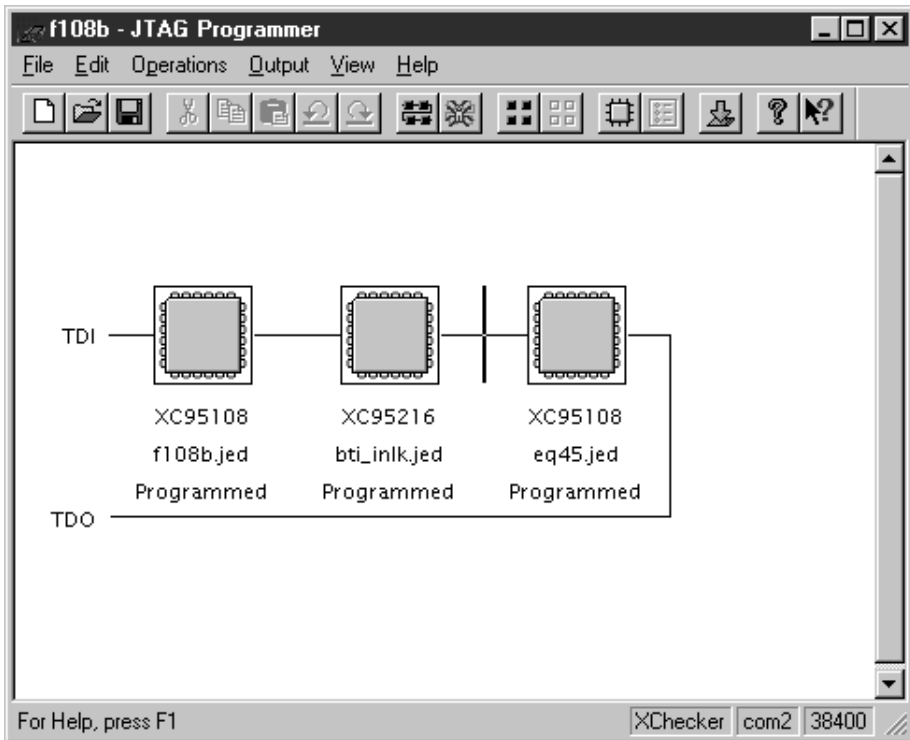

Figure 3-11 Programmed Chain

Selecting Operations

There are two ways to set up the chain for JTAG Programmer operations. The first is to highlight a part and select an operation for it using the Operations menu. You select an operation from the menu, then highlight the next part and select an operation for it, or you may highlight all parts and select an operation for all parts.

The other way is to use the Chain Operations dialog box. This presents you with a “spreadsheet” approach to boundary-scan chain. This method allows you select and execute operations for all the parts in the chain, all from the same dialog box. To access this dialog box:

Operations → Chain Operations...

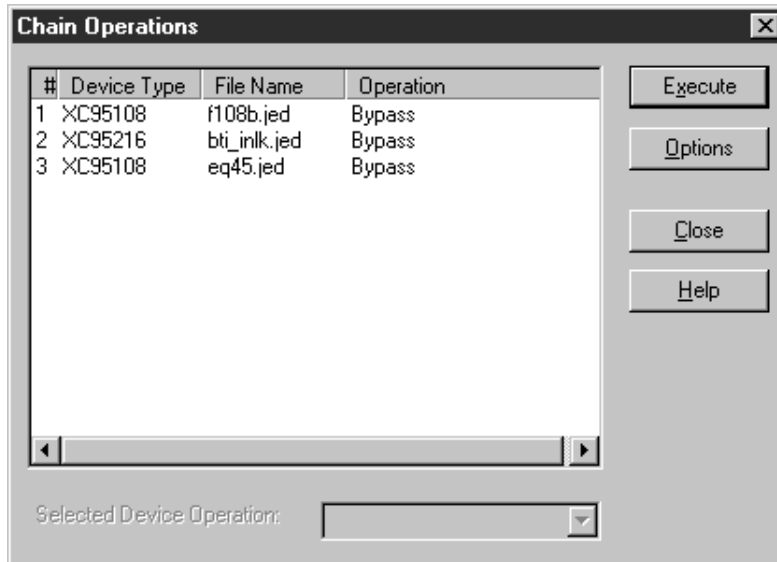

Figure 3-12 Chain Operations

The dialog box appears. In the Operations column you may change the operation of any part by clicking once on the current device to highlight it, then clicking once on the down arrow adjacent to Selected Device Operation. This will produce a pull-down menu showing the operations you can set for that part.

Bypass is the only supported mode of Operation for non-Xilinx parts. These parts will appear under Device Type. Note that Bypass is selected as the default Operation of each foreign part.

Select the Execute button. Download will begin.

In either operation mode a pop-up menu appears and delivers processing messages. When processing has completed, a message log is available to examine the results of the execution.

Modifying a Chain

The Edit menu provides easy means for inserting and deleting parts from a chain, as well as the means to assign a new JEDEC file to a part.

Adding a Device

To insert a device into the chain, use the Add Device command. First make sure that the prompt is at the location in the chain where you want to insert the device. If it is not, use either the mouse or the arrow keys to move it. Then insert the device as follows:

Edit → Add Device

Changing a Part

To change the jedec file associated with a device in the chain, highlight the device and select:

Edit → Properties

Use the browse key to select another jedec file or simply enter the path and filename of the file. The program will associate the new file with the device.

Each jedec assigns a device type to the device in the chain. If the jedec file was not created for the actual device you have on your board, an error will result when you attempt to program the device.

For an 1800 prom, clicking OK on the properties dialog displays a list of 1800 parts which can fit the specified prom file. Select the desired part name and click OK.

Deleting a Part

To delete an entry in the device chain, use the Cut command. All devices move up one entry in the chain.

Edit → Cut

Selecting the Entire Chain

To select the entire chain for an operation, use

Edit → Select All

To unselect the chain:

Edit → Unselect All

When operating in SVF mode, chain modifications are not allowed so as to ensure that the resulting SVF is self-consistent.

Saving the Chain Description

To save a JTAG Programmer chain description for later use, create a Chain Description File (.cdf) using:

File → Save

If the chain has not been previously saved, the Save As dialog box will appear. This screen will allow you to select a directory and path to place the file in. You can also name the file, but you should retain the .cdf file extension. If you wish to save your file under another name than already selected, use:

File → Save As...

To name your file, use the mouse to highlight Untitled or the old file name on the File Name line, then type in the name you want and click once on OK.

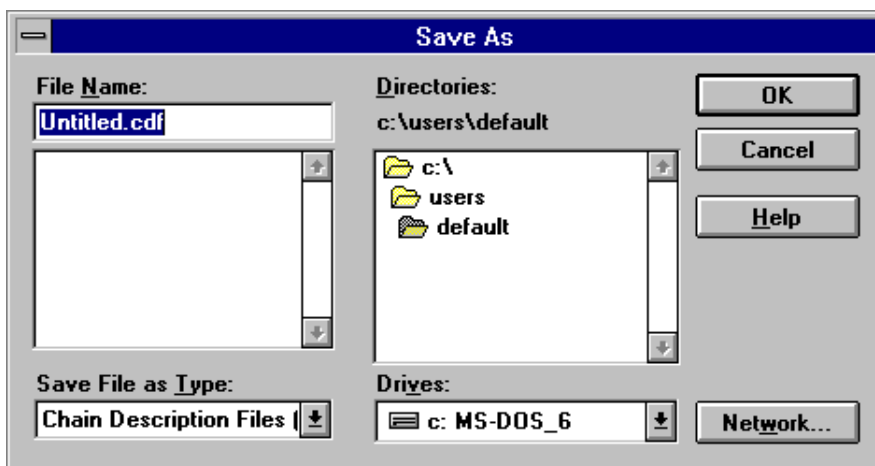

Saving a File

Debugging a Chain

The debugger provides you with a method to apply boundary-scan test access port stimulus. This feature allows you to set TDI and TMS, then pulse TCK a specified number of times. You can monitor TDO, TDI and TMS using an oscilloscope or logic probe to see if the boundary-scan chain is operating correctly. The debugger also displays the current TAP state and allows you to reset the chain to Run Test Idle.

To access the debugger:

File → Debug Chain

The Boundary-Scan Chain Debug dialog box appears as shown in Figure 3-13.

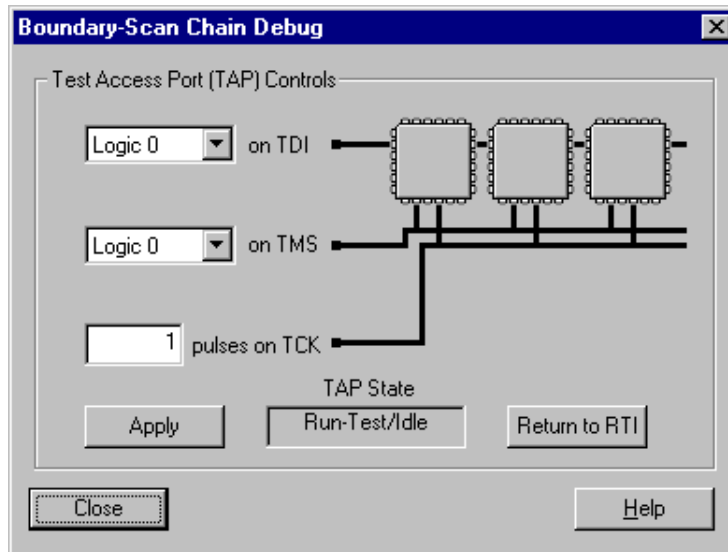

Figure 3-13 Debug

The features of this dialog box operate as follows:

- The first selection box allows you to set a logic state for TDI. This state will not be set until you click on the Apply button.
- The second selection box allows you to set a logic state for TMS. This state will not be set until you click on the Apply button.
- The third selection box allows you to set a number of pulses to apply to TCK. These pulses will not be sent until you click on the Apply button. If you want to see the pulses again, click the Apply button as often as you want.
- The TAP State window displays the current state of the controller.
- The Return to RTI (Run Test Idle) button executes a Test Logic Reset, then returns to Run Test Idle.

Data Security Selection

Any Xilinx CPLD device selected for programming can be secured with the Write Protect or Read Protect or both.

When enabled, Read Protect disables reading the programmed contents of a device (the Device ID and usercode/signature and boundary scan register remain readable).

Write Protect allows only the reading of the programmed data. The device contents cannot be altered or re-programmed.

When both Read Protect and Write Protect are enabled, the device can be neither read nor re-programmed.

To enable either security function simply place a check in the corresponding box when programming the device.

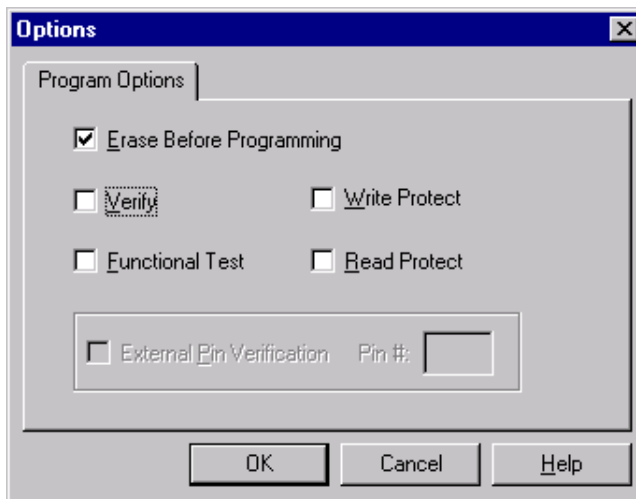

Figure 3-14 Data Selection (Program Options)

Data security operations can be overridden only by erasing the device. For Read Protection override, you simply erase the part. For Write Protection override, you must select the override write protect option from the Erase Options dialog box.

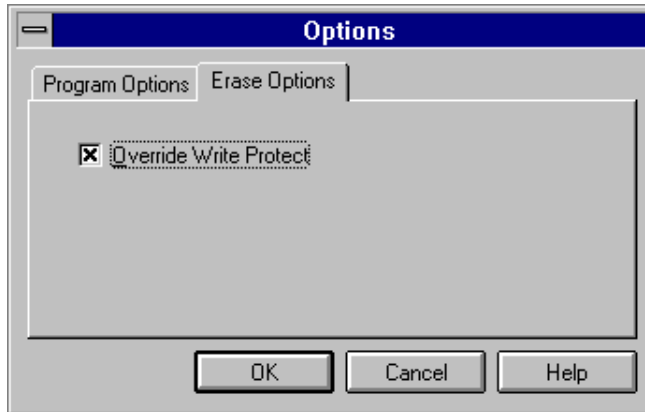

Figure 3-15 Data Selection (Erase Options)

Options Specific to Proms

Parallel load: This option is used to determine if the prom is to be read out serially or in parallel on D0-D7 data lines. By default, the prom is configured to be read out serially. By selecting the parallel load option, the prom can be programmed to output data on lines D0-D7 to be used to configure a Virtex device in the Select-map mode, or a Spartan device in Express mode.

Load FPGA: By selecting this option the prom will automatically start FPGA configuration at the end of programming (if the programming is successful). This option sets the CF low for 300 ns, which in turn causes the prog to be pulled low (on the FPGA) which initiates configuration of the FPGA. This mechanism will only work if the prom and the FPGA are connected as required for configuration purposes.

Skip User Array: This option gives you the flexibility to alter miscellaneous bits (security, load FPGA, Select Map) without affecting the contents of the user array. This makes it possible to set these options after programming the user array. Note that because these parts are Flash based, if you program these bits, you cannot reverse these bits without erasing the entire array (consistent with the behavior of the security option).

Generating SVF Files

Serial Vector Format (SVF) files are used when programming all devices on automatic test equipment (ATE). The JTAG Programmer allows you to create .svf files for use with ATE systems. One .svf file is created for every device in your chain. To do this you need to create a new SVF file:

Output → Create SVF File...

The SVF Options dialog will appear:

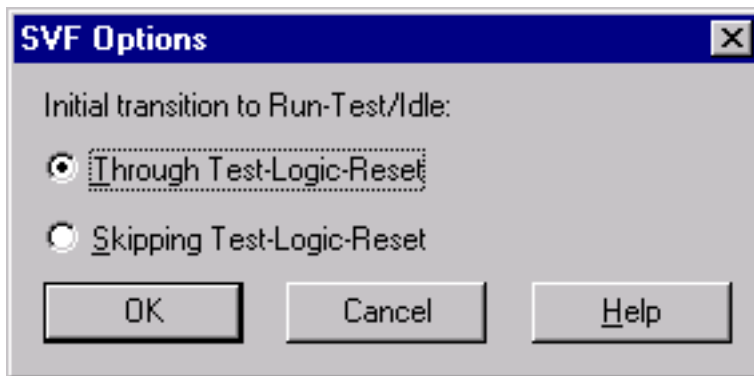

SVF Options

By default, SVF files are generated with instructions to begin execution by transitioning to the Test-Logic-Reset Tap controller state. Some third part tools prefer that the SVF files not specify this transition, and always start in the Run-Test-Idle Tap controller state. You can select the appropriate option using this dialog box. Click OK.

Then the Create a New SVF File dialog box will appear.

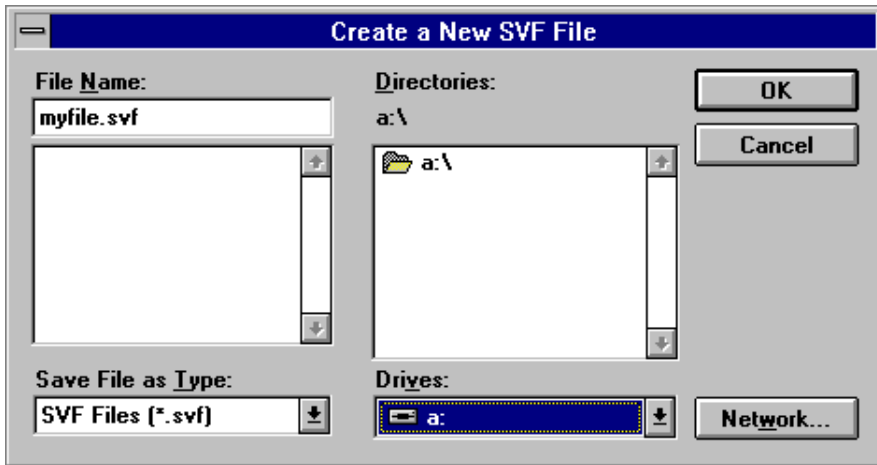

Figure 3-16 Create an SVF File

Select a name and a directory to create the new file in, then click OK.
To append your vectors to an existing SVF file, use:

Output → Append to SVF File...

The Append to an Existing SVF File dialog box will appear.

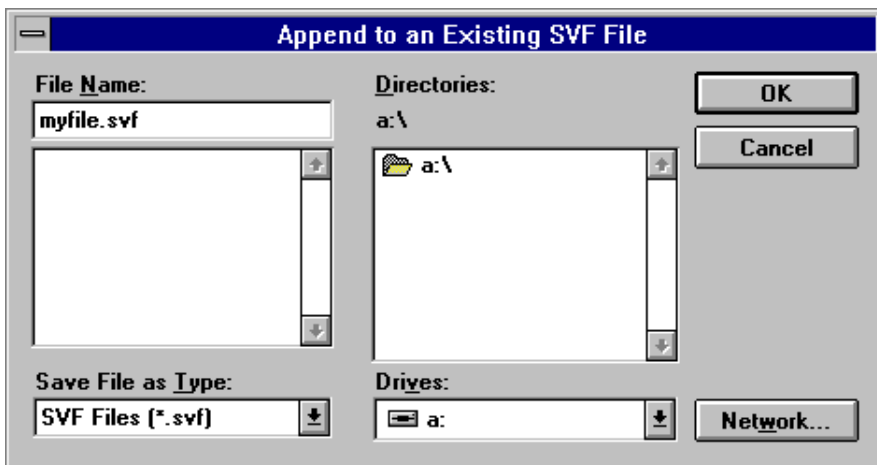

Figure 3-17 Append to an SVF File

Select a file to append to and click OK.

Program, Verify, Erase, Functional Test, Get Device ID and Get Signature/Usercode are allowed operations in SVF mode.

After identifying the SVF file to be used for collection of SVF data, operate on the devices in your boundary-scan chain in the manner described previously. Remember that in SVF mode, chain editing operations are not allowed to ensure that the resulting SVF file will be self-consistent.

Xilinx provides software on the Xilinx Website that converts SVF files into ATE vectors. Visit our site at www.xilinx.com for more information.

Substituting with Version n Devices

If you generated SVF files for XC95108 or XC95216 Version 0 devices, the files will work without modification on any later version devices. If you wish, however, to take advantage of improved ISP capabilities available on later version silicon devices, and you are certain that you have such devices in your boundary-scan chain, then you can generate version specific SVF files using the following techniques:

Using the Batch Tool (jtagprog)

Use the batch tool as follows:

1. Invoke the tool to generate SVF files:
 1. `jtagprog -svf`
 2. When specifying the `part_type` in the `part` command identify Version 1 silicon by appending “_vn” to the part name (where n is the version number device being used). For example, to specify a chain of Version 1 XC95216s and XC95108s:
 3. `part xc95216_v1:design216a xc95108_v1:design108 xc95216_v1:design216b`
 4. Next, specify operations as usual to generate the required SVF files.

Using the JTAG Programmer

In your `$XILINX/data` directory you will notice BSDL files with the following names:

`xc95108.bsd`

xc95108_v1.bsd

xc95216.bsd

xc95216_v1.bsd

The BSDL files with the “_v1” in their names describe the Version 1 silicon. Similarly, those with “_v2” are for Version 2 devices. To get the software to use Version 1 BSDL files for all devices, you must “trick” the application by renaming files as follows:

1. Rename xc95108.bsd to xc95108_v0.bsd
2. Rename xc95216.bsd to xc95216_v0.bsd
3. Rename xc95108_v1.bsd to xc95108.bsd
4. Rename xc95216_v1.bsd to xc95216.bsd
5. Invoke the JTAG Programmer and set it to generate SVF files as described earlier in this section. When you use the JTAG Programmer, it will default to using the xc95216.bsd and xc95108.bsd files to describe the parts. This will allow access to all Version 1 features.
6. When you are done programming, remember to change the file names back so that the software will work correctly in non-SVF modes:
7. Rename xc95108.bsd to xc95108_v1.bsd
8. Rename xc95216.bsd to xc95216_v1.bsd
9. Rename xc95108_v0.bsd to xc95108.bsd
10. Rename xc95216_v0.bsd to xc95216.bsd

Designing Boundary-Scan and ISP Systems

This chapter gives design considerations for boundary-scan and ISP systems. It contains the following sections:

- [Connecting Devices in a Boundary-Scan Chain](#)
- [FPGA Device Considerations](#)

Connecting Devices in a Boundary-Scan Chain

All devices in the chain share the TCK and TMS signals. The system TDI signal is connected to the TDI input of the first device in the boundary-scan chain. The TDO signal from that first device is connected to the TDI input of the second device in the chain and so on. The last device in the chain has its TDO output connected to the system TDO pin. This configuration is illustrated in Figure 4-1.

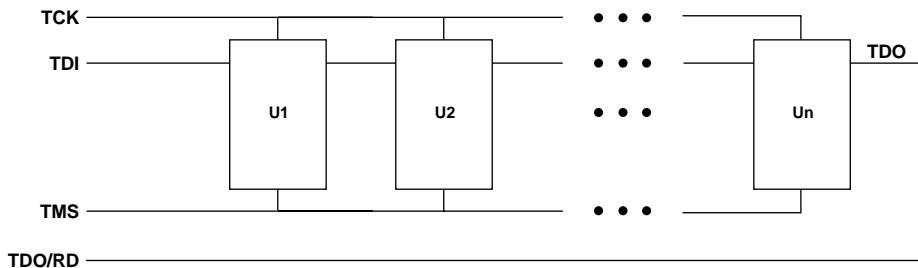

X8006

Figure 4-1 Single Port Serial Boundary-Scan Chain

The boundary-scan standard requires pull-up resistance to be supplied internally to the TDI and TMS pins by the chips, but no

particular value is required. This allows vendors to supply whatever they choose and still remain in full compliance. Because of this, very long boundary-scan chains, or chains using parts from multiple vendors, may present significant loading to the ISP drive cable. In these cases:

- Use the latest Xilinx download cables (parallel cables with serial numbers greater than 5000, any X-Checker cable or MultiLINX cable).
- Consider including buffers on TMS or TCK signals interleaved at various points on your JTAG circuitry to account for unknown device impedance.
- Some users have noted that their designs appear to experience erase time or programming time extension as the design progresses, particularly for long chains. This is probably due to switching noise.
- Put the rest of the JTAG chain into HIGHZ mode by selecting the HIGHZ preference on JTAG Programmer when programming a troublesome part.
- If free running clocks are delivered into boundary-scan devices, it may be necessary to disconnect or disable their entry into these devices during ISP or boundary-scan operations.
- Charge pumps, the heart of the XC9500/XL/XV ISP circuitry, require a modest amount of care. The voltages to which the pumps must rise are directly derived from the external voltage supplied to the VCCINT pins on the XC9500/XL/XV parts. Because these elevated voltages must be within their prescribed values to properly program the CPLD, it is vital that they be provided with very clean (noise free) voltage within the correct range. This suggests the first two key rules:
- Make sure VCC is within the rated value for the devices you are using.
- Provide both 0.1 and 0.01 uF capacitors at every VCC point of the chip, and attached directly to the nearest ground.

FPGA Device Considerations

JTAG Programmer supports the configuration of Xilinx FPGA devices through the boundary-scan test access port (TAP). In order to

enable boundary-scan-based configuration capabilities for FPGA devices, you must design your systems and prepare your configuration bitstreams in the following manner.

Bitstream Considerations

JTAG Programmer only accepts FPGA configuration files in the binary bitstream format (.bit). It does not allow configuration using the ASCII raw bits (.rbit) format.

Express mode bitstreams cannot be used to configure devices via boundary-scan.

If you are using XC4000, Spartan or SpartanXL, make certain that the boundary-scan (BSCAN) symbol has been included in your design. If it has not then the bitstream will also not be usable for boundary-scan based configuration. Standard examples for instantiating the BSCAN symbol in FPGAs are included in Appendix F.

Keep your device bitstream files separate for each device in the boundary-scan chain. JTAG Programmer requires you to assign a single bit file to each device. It cannot manipulate composite bit files.

Virtex Considerations

When generating bitstreams for Virtex devices, always select the option to choose the JTAG clock as the startup clock.

XC4KXLA, XV, Spartan XL Considerations

When generating bitstreams for these devices, always select the option to enable BSCAN status.

Device Set-up

Xilinx recommends that all the mode pins of the devices be tied low before starting the configuration. This is recommended for all XC4000, XC5000 and Spartan device families.

In order to enable the boundary-scan circuitry in the device, you must install a pull down resistor on the INIT pin. The value of the pull down should be selected so as to draw the INIT pin to approximately 0.5V. Typically a pull down of approximately 1KOhm should accomplish this.

Verifying Device Configuration

The XC4000 (not the XLA and XV), XC5000 and Spartan (not the SpartanXL or Spartan-II) devices freeze if data errors occur during boundary-scan configuration. The only method for unlocking the frozen device is to reset the power to the device or pulse the PROGRAM pin low. (This latter method would have to be accomplished manually since the download cables (when being used for boundary-scan operations), do not have control over the PROGRAM pin. Although this situation is rare, it is possible to design your system so as to detect if that condition has occurred. The JTAG Programmer software allows you to check for this in three ways:

1. Assume successful verification - since it is a low probability event, simply configure the device and run. The drawback is that the failure of the device is then only detected at run-time.
2. Readback verify the configuration memory - after configuring, readback the contents of the configuration memory and check against the source bitstream file. If the device has frozen, the returned bits will be incorrect. Since bit files can be large, this might be time consuming.
3. Tie a free pin on the device to ground - after configuring, the software will perform an EXTEST instruction to read the device pin value. If the device has locked up, the pin value will not be read correctly.

Device Behavior Notes

Any verify operation executed immediately after configuration without boundary-scan functionality enabled will fail because the test access port no longer exists. Always remember to instantiate the BSCAN symbol for reliable operation of your XC4000, XC5200, Spartan and SpartanXL devices.

The implementation of boundary-scan based configuration of FPGAs precludes the use of concurrent ISP. For this reason, the concurrent mode preference is disabled (or ignored) when FPGAs are selected to be operated upon.

Boundary Scan Basics

This appendix discusses IEEE Standard 1149.1 instructions.

Boundary Scan/IEEE Standard 1149.1

Design complexity, difficulty of loaded board testing, and the limited pin access of surface mount technology led industry leaders to seek accord on a standard to support the solution of these problems.

JTAG Boundary Scan, formally known as IEEE Standard 1149.1, is primarily a testing standard created to alleviate the growing cost of designing and producing digital systems. The primary benefit of the standard is the ability to transform extremely difficult printed circuit board testing problems (that could only be attacked with ad-hoc testing methods) into well-structured problems that software can handle easily and swiftly.

The standard defines a hardware architecture and the mechanisms for its use to solve the aforementioned problems.

What can it be used for?

Although primarily a testing standard for on-chip circuitry, the proliferation of the standard has opened the door to a wide variety of applications. The standard itself defines instructions that can be used to perform functional and interconnect tests as well as built-in self test procedures.

Vendor-specific extensions to the standard have been developed to allow execution of maintenance and diagnostic applications as well as programming algorithms for reconfigurable parts. It is the latter that have been implemented (in addition to all the mandatory opera-

tions of the standard and some optional ones) in the FastFLASH family.

How does it work?

The top level schematic of the test logic defined by IEEE Std 1149.1 includes three key blocks:

The TAP Controller

This responds to the control sequences supplied through the test access port (TAP) and generates the clock and control signals required for correct operation of the other circuit blocks.

The Instruction Register

This shift register-based circuit is serially loaded with the instruction that selects an operation to be performed.

The Data Registers

These are a bank of shift register based circuits. The stimuli required by an operation are serially loaded into the data registers selected by the current instruction. Following execution of the operation, results can be shifted out for examination.

JTAG Test Access Port

The JTAG Test Access Port (TAP) contains four pins that drive the circuit blocks and control the operations specified. The TAP facilitates the serial loading and unloading of instructions and data. The four pins of the TAP are: TMS, TCK, TDI and TDO. The function of each TAP pin is as follows:

TCK - this pin is the JTAG test clock. It sequences the TAP controller as well as all of the JTAG registers provided in the XC95108.

TMS - this pin is the mode input signal to the TAP Controller. The TAP controller is a 16-state FSM that provides the control logic for JTAG. The state of TMS at the rising edge of TCK determines the sequence of states for the TAP controller. TMS has an internal pull-up resistor on it to provide a logic 1 to the system if the pin is not driven.

TDI -this pin is the serial data input to all JTAG instruction and data registers. The state of the TAP controller as well as the particular

instruction held in the instruction register determines which register is fed by TDI for a specific operation. TDI has an internal pull-up resistor on it to provide a logic 1 to the system if the pin is not driven. TDI is sampled into the JTAG registers on the rising edge of TCK.

TDO - this pin is the serial data output for all JTAG instruction and data registers. The state of the TAP controller as well as the particular instruction held in the instruction register determines which register feeds TDO for a specific operation. Only one register (instruction or data) is allowed to be the active connection between TDI and TDO for any given operation. TDO changes state on the falling edge of TCK and is only active during the shifting of data through the device. This pin is three-stated at all other times

JTAG TAP Controller

The JTAG TAP Controller is a 16-state finite state machine, that controls the scanning of data into the various registers of the JTAG architecture. The state of the TMS pin at the rising edge of TCK is responsible for determining the sequence of state transitions. There are two state transition paths for scanning the signal at TDI into the device, one for shifting in an instruction to the instruction register and one for shifting data into the active data register as determined by the current instruction.

JTAG TAP Controller States

Test-Logic-Reset. This state is entered on power-up of the device whenever at least five clocks of TCK occur with TMS held high. Entry into this state resets all JTAG logic to a state such that it will not interfere with the normal component logic, and causes the IDCODE instruction to be forced into the instruction register.

Run-Test-Idle. This state allows certain operations to occur depending on the current instruction. For the XC9500/XL/XV family, this state causes generation of the program, verify and erase pulses when the associated in-system programming (ISP) instruction is active.

Select-DR-Scan. This is a temporary state entered prior to performing a scan operation on a data register or in passing to the Select-IR-Scan state.

Select-IR-Scan. This is a temporary state entered prior to performing a scan operation on the instruction register or in returning to the Test-Logic-Reset state.

Capture-DR. This state allows data to be loaded from parallel inputs into the data register selected by the current instruction on the rising edge of TCK. If the selected data register does not have parallel inputs, the register retains its state.

Shift-DR. This state shifts the data, in the currently selected register, towards TDO by one stage on each rising edge of TCK after entering this state.

Exit1-DR. This is a temporary state that allows the option of passing on to the Pause-DR state or transitioning directly to the Update-DR state.

Pause-DR. This is a wait state that allows shifting of data to be temporarily halted.

Exit2-DR. This is a temporary state that allows the option of passing on to the Update-DR state or returning to the Shift-DR state to continue shifting in data.

Update-DR. This state causes the data contained in the currently selected data register to be loaded into a latched parallel output (for registers that have such a latch) on the falling edge of TCK after entering this state. The parallel latch prevents changes at the parallel output of these registers from occurring during the shifting process.

Capture-IR. This state allows data to be loaded from parallel inputs into the instruction register on the rising edge of TCK. The least two significant bits of the parallel inputs must have the value 01 as defined by IEEE Std. 1149.1, and the remaining 6 bits are either hard-coded or used for monitoring of the security and data protect bits.

Shift-IR. This state shifts the values in the instruction register towards TDO by one stage on each rising edge of TCK after entering this state.

Exit1-IR. This is a temporary state that allows the option of passing on to the Pause-IR state or transitioning directly to the Update-IR state.

Pause-IR. This is a wait state that allows shifting of the instruction to be temporarily halted.

Exit2-IR. This is a temporary state that allows the option of passing on to the Update-IR state or returning to the Shift-IR state to continue shifting in data.

Update-IR. This state causes the values contained in the instruction register to be loaded into a latched parallel output on the falling edge of TCK after entering this state. The parallel latch prevents changes at the parallel output of the instruction register from occurring during the shifting process.

JTAG Instructions Supported in FastFLASH Parts

JTAG Programmer software uses sequences of these JTAG instructions to perform programming and verification operations selected by the user. However, execution of individual JTAG instructions is not supported by this software.

Mandatory Boundary Scan Instructions

BYPASS. The BYPASS instruction allows rapid movement of data to and from other components on a board that are required to perform test operations.

SAMPLE/PRELOAD. The SAMPLE/PRELOAD instruction allows a snapshot of the normal operation of a components to be taken and examined. It also allows data values to be loaded onto the latched parallel outputs of the boundary scan shift register prior to the selection of other boundary-scan test instructions.

EXTEST. The EXTEST instruction allows testing of off-chip circuitry and board level interconnections.

Optional Boundary Scan Instructions

INTEST. The INTEST instruction allows testing of the on-chip system logic while the components are already on the board.

HIGHZ. The HIGHZ instruction forces all drivers into high impedance states.

IDCODE. The IDCODE instruction allows blind interrogation of the components assembled onto a printed circuit board to determine what components exist in a product.

USERCODE. The USERCODE instruction allows a user-programmable identification code to be shifted out for examination. This allows the programmed function of the component to be determined.

FastFLASH Reconfiguration Instructions

ISPEN. The ISPEN instruction activates the FastFLASH part for in-system programming.

FPGM. The FPGM instruction is used to program the fuse locations at a specified address.

FERASE. The FERASE instruction is used to perform an erase of a block of fuse locations.

FVIFY. The FVIFY instruction is used to read the programming of the fuse locations at a specified address.

ISPEX. The ISPEX instruction loads the programmed values into the device memory. It then activates the device to operate according to the programmed values.

FPGMI. The FPGMI instruction is used to program fuse locations sequentially from a preset starting address.

FVFI. The FVFI instruction is used to read the programming of fuse locations sequentially for a preset starting address.

FBULK. The FBULK instruction is used to perform an erase of either all function blocks or all Fastconnect blocks of a device.

Appendix B

JTAG Parallel Cable Schematic

This appendix contains a schematic of the Parallel Download Cable. It is included in case you want to build your own download cables. schematic, Figure B-1, is our current version of the Parallel Download Cable. If you want to build a parallel cable, this is the recommended schematic.

Note You must use recommended lengths for parallel cables. Xilinx cables are typically six feet (about two meters) in length.

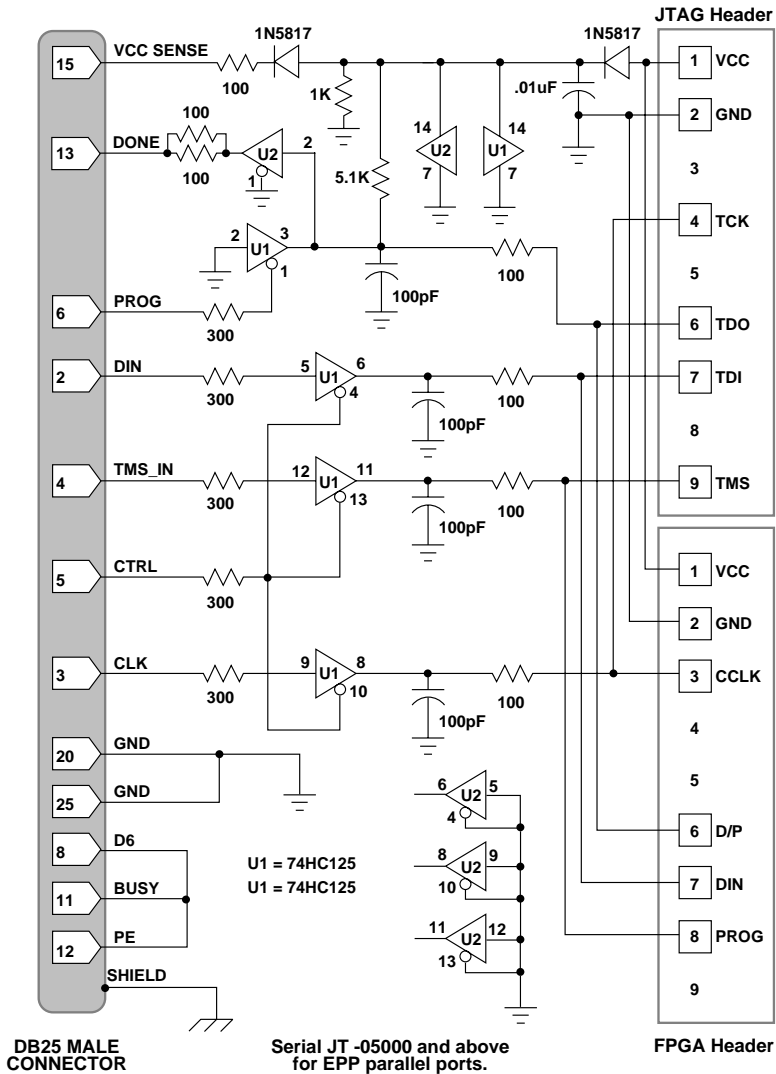

X7557

Figure B-1 Parallel Download Cable

Troubleshooting Guide

This chapter is a simple guide to understanding the more common issues you might encounter when configuring CPLDs with JTAG Programmer. These issues are likely to fall into three groups; communication, improper connections, and improper or unstable V_{CC} .

- [Communication](#)

This section describes several issues that involve the integrity of the bitstream that JTAG Programmer transmits to the target CPLDs, and the correct connection of the boundary-scan chain.

- [Improper Connections](#)

This section involves assigning configuration pins to invalid signals or voltage levels.

- [Improper or Unstable VCC](#)

This section describes several causes of incorrect configuration sequences and incorrect responses from the target system.

- [Boundary Scan Chain Errors](#)

If you experience a consistent error that identifies a break in your boundary-scan chain, go to this section.

- [System Noise](#)

If you experience intermittent problems characteristic of system noise, go to this section.

Communication

Observing the following guidelines should minimize the communication difficulties that can occur between the cable hardware and the target system.

- Do not attach extension cables to the target system side of the cable; this can compromise configuration data integrity and cause checksum errors.
- Attach the cable configuration leads firmly to the target system.
- After connecting the target system, specify the chain configuration using the part command. Then use the "partinfo -id part_name" command to read the IDCODE from each part in the system. This will verify the integrity of the boundary-scan chain. If you are using the Graphical User Interface:
 - Operations → Get Device ID
- Use the verify feature to assure integrity of the configuration data. You can do this from the command line with the `-v` option or in the interactive mode by specifying the verify command.
- When using the JTAG Programmer software with the cable on a PC to download, the process may stop with data communications errors. This is caused by serial port communication inefficiencies in the Windows environment. To set your PC to better handle serial communications at 38400 baud, add (or modify) the following lines to the 386Enh section of your SYSTEM.INI file. This file is located in the Windows directory of your system.
 - COM1Buffer=32768
 - COM2Buffer=32768
 - COMBoostTime=10240

Improper Connections

Check the following:

- Always make sure that cable leads are connected properly.
- Connecting the cable leads to the wrong signal will cause permanent damage to cable internal hardware. On a parallel cable, you must connect VCC to +5 V, +3.3V or +2.5V, and GND to ground. On an XChecker cable, you can connect VCC directly to 5V and GND to ground, but need an adapter to connect VCC to 3.3V or 2.5V. The part number is HW-XCH3V.
- For workstations, you must have read and write permissions to the port to which you connect the cable. JTAG Programmer might

issue a message stating that the cable is not connected to port ttyx. When you see this message, follow the check list below:

- The board must have the power on, since the cable uses power from the board.
- Check the device driver using the following command string:
- `ls -l /dev/ttya /dev/ttyb`
- The result should be the following:
- `crw-rw-rw- 1 root12,0 month date time /dev/ttya`
- `crw-rw-rw- 1 root12,1 month date time /dev/ttyb`
- Reconnect the cable to another valid port.
- Read the `/etc/ttytab` file. There should be two lines, as follows:
- `ttya"/usr/etc/getty std.9600" unknown off local secure`
- `ttyb"/usr/etc/getty std.9600" unknown off local secure`
- If you use a port to connect a modem or a remote login, you cannot use that port. The port must be on. Consult your System Administrator if the information the `/etc/ttytab` file is different than what is listed in the aforementioned list.

Improper or Unstable VCC

If you are having problems with unstable VCC, try the following:

Never connect the control signals to the cable before VCC and ground. Xilinx recommends the following sequence:

- Turn off power to the target system.
- Connect VCC ground, and then the signal leads,
- Turn on power to the target system.
- The XChecker Cable has an internal FPGA. As with any CMOS device, the input/output pins of the internal FPGA should always be at a lower or equal potential than the rail voltage to avoid internal damage.
- Make sure VCC rises to a stable level within 10ms. Stable VCC should be between 4.75 V and 5.25 V.
- In the event of power glitches, reset the cable by selecting:

- Output → Cable Reset

Boundary Scan Chain Errors

If you experience a consistent error that identifies a break in your boundary-scan chain but are unable to identify such a discontinuity then execute the following steps:

Create a command file to be used with the batch version of the JTAG Programmer (jtagprog). In this batch file specify your boundary-scan chain configuration using the part command and about 500 idcode queries as follows:

```
part xc9572:design72 xc95108:design108
```

```
partinfo -id design108
```

```
partinfo -id design108
```

```
partinfo -id design108
```

```
.
```

```
.
```

```
.
```

```
partinfo -id design108
```

```
quit
```

Save the file as test.cmd and then invoke the tool as follows:

```
jtagprog -batch test
```

The tool will execute the device id command 500 times before quitting. While this is going on use the oscilloscope to probe the pins of the boundary scan test access port (TAP) at the system entry point and at each individual part.

The boundary scan integrity check sequences the TAP through a TRST sequence (TMS set to 1, TCK pulsed 5 times) and then transitions all devices to the RunTest/Idle state (TMS set to 0, TCK pulsed once). Then, all parts are run through a CAPTURE -IR sequence while TDI is set to 1 (1s will be shifted in). If you look in the device BSDL files you will see the expected capture sequence defined in the “instruction capture” field. For all XC9500/XL/XV parts this sequence is a “1” followed by seven zeros. You should therefore see

the "1" on TDO after the falling edge of the 4th TCK pulse after the TRST sequence. On the next TCK pulse TDO should return to zero.

The CAPTURE -IR sequence consists of the following (starting from RunTest/Idle), as illustrated in Figure C-1.

TMS set to 1; TCK pulsed twice.

TMS set to 0; TCK pulsed twice.

TCK pulsed (number of bits in instruction register -1) times.

TMS set to 1; TCK pulsed twice.

TMS set to 0; TCK pulsed once.

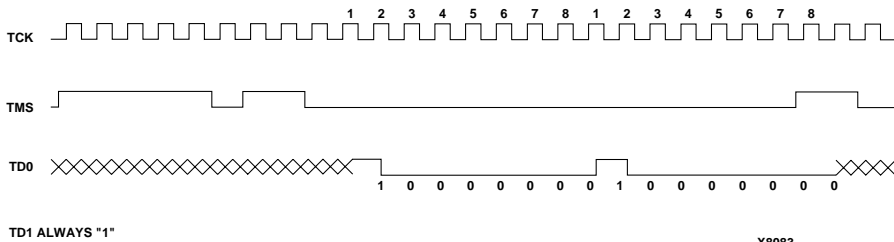

Figure C-1 Sample Expected Waveform

Check for the following:

The expected number of TCK pulses occur.

The same TMS sequence occurs for each part.

The TDO is not shorted or floating between parts, or floating at the system interconnect point.

Make certain that all 4 TAP signals are getting into each part (Note that both TDI and TMS have internal pull-ups on them which could keep the device in TRST mode if TMS is not properly connected).

You may also use the Debug Chain dialog and a logic probe or oscilloscope to transition the TAP state machine directly and observe results.

System Noise

You can check for system noise by running the IDCODE looping instruction. The IDCODE should read correctly 100% of the time. If by test you find that the instruction is working less than 100% of the time, you may be experiencing system noise. To use IDCODE looping:

Operations → Idcode looping

This will display the Edit window. Enter the number of loops you desire and click OK.

To remedy a problem with system noise, select Use HIGHZ instead of BYPASS from the Preferences dialog box. This places devices into tri-state mode and reduces susceptibility to system noise. To find this box use:

File → Preferences

The Preferences dialog box will appear. Place a check in the box adjacent to Use HIGHZ instead of BYPASS.

Error Messages

This section describes the error messages that JTAG Programmer may generate. Following each error message, there is a suggested workaround.

Error Messages

Command file bat file.cmd is not found.

Make sure that the command file you specified is in the current directory or the environment search path. Make sure that the command file has the ".cmd" extension

Internal Error — Command table syntax error Cmd=valid_command.

This is an internal program error that normally should not occur. Try entering the command sequence again. If the error persists, try reinstalling your JTAG Programmer software. If the error reappears, call Xilinx Technical Support. Be prepared to duplicate the error and reference specific files or examples.

Cannot open output file file_name.

Check available disk space. Current directory or file must have write permission.

Cannot create output file file_name.

Check available disk space. Current directory or file must have write permission.

Cannot open input file file_name.

Make sure the file_name file exists in your working directory or in the environment search path. Current directory or file must have write permission.

File file_name is not found.

The file_name file does not exist in the current directory or search path. Make sure that the file_name file exists in your working directory or in the environment search path.

Help file jtagprog.hlp is not accessible

Make sure that the XILINX environment variable points to the installation directory in the PC. Also make sure that jtagprog.hlp is in the installation\MSG directory. If you cannot find jtagprog.hlp in the installation\MSG directory, you must reinstall the JTAG Programmer software.

No help for command command entered.

Help is not available for the specified command. Refer to the Interactive Mode Commands section in Appendix E for help.

Cannot save configuration to file_name.pro.

Check available disk space. Current directory or file must have write permission.

Invalid command at line line number.

Check the file xchecker.pro in your current directory for illegal commands. Delete the xchecker.pro file. JTAG Programmer creates a new profile when you exit from the session.

Ambiguous command.

Enter the minimum unique characters that identify the command or enter complete commands with no abbreviations.

Invalid command.

The command you entered is illegal. Refer to the Interactive Mode Commands section in Appendix E for help.

Invalid number of arguments.

Refer to the Interactive Mode Commands section in Appendix E for help.

Invalid option selected option.

Refer to the Command-Line Options and the Interactive Mode Commands sections in Appendix E for help.

Invalid value given to parameter.

Refer to the Command-Line Options and the Interactive Mode Commands sections in Appendix E for help.

Value is required for command entered.

Refer to the Interactive Mode Commands section in Appendix E for help.

System Error Messages

System error codes are usually a string of messages generated by your operating system.

System file error code.

System error codes are usually a string of messages generated by your operating system.

Cable is not initialized.

Reissue the Reset command with the `-c` option, or cycle power to the XChecker cable and then issue the Reset command with the `-c` option. See the Improper or Unstable VCC section in Appendix E.

Cable is not located.

No cable has been recognized at any port. Make sure there is power to your board and to the XChecker cable. If you are using the test fixture, you must connect VCC and ground to it. The XChecker cable draws power from your target system, not from your host computer. Also make sure the RS-232 connector is firmly attached.

Invalid port name.

Refer to the XChecker Hardware section in Appendix E for help.

Invalid baud specified.

Refer to the XChecker Hardware section in Appendix E for help.

Cable is not reset.

Cycle power to the cable. Use the Reset command with the `-c` option.

Communication line is broken.

Run the Reset command with the `-c` option. Also make sure there is power to your board and to the XChecker cable. Check all power and port connections.

Communication checksum error.

Check for induced noise in your target system or from your target system into the XChecker connections. Do not use cable extensions. The XChecker cable length is tested to produce minimal noise levels. Remember that a logic High must be 80-100% of VCC and a Logic Low must be 0-25% of VCC.

Cable has no power.

Make sure there is power from your target system to the XChecker cable. The cable draws power from an external source, not from the host computer.

Communication time-out.

JTAG Programmer has not received an expected signal; for example, a system trigger to initiate readback or data coming from readback. Make sure that the selected options for trigger and readback are what you intended. Check all connections.

Cannot communicate to the cable.

Run the Reset command with the `-c` option. Also, ensure that there is power to your board and to the XChecker cable. Check all connections. Make sure the RS-232 connector is firmly attached.

Cable datafile `file_name` is empty.

Run the Reset command with the `-c` option. Make sure that the XILINX environment variable points to the installation directory on the PC.

No XChecker cable is connected to the port `portname`.

Ensure that there is power to your board and to the XChecker cable. You must connect VCC and ground to the test fixture, if you are using it. The cable draws power from your target system, not from the host computer. Ensure that the RS-232 connector is firmly attached.

No XChecker cable is connected to the system.

Ensure that there is power to your board and to the cable. You must connect VCC and ground to the test fixture, if you are using it. XChecker draws power from your target system, not from the host computer. Ensure that the RS-232 connector is firmly attached.

Fail reading cable status.

Try using the Reset command with the cable option. Ensure that there is power to your board and to the cable. Check all connections.

Unsupported command for this cable.

See the Interactive Mode Commands section for valid with the XChecker cable. If you are using the previous parallel or serial download cables, you can only use the Load command to download.

Read only number of bits received.

Check all connections. Check for noise that may be induced into your target system or from your target system into the XChecker connections. Do not use cable extensions. The XChecker cable length is tested to produce minimal noise levels. Remember that a logic High must be 80-100% of VCC and a Logic Low must be 0-25% of VCC.

Invalid baud rate. Current baud rate is baud rate.

See Table 2-1 for the valid baud rates for your computer.

Missing baud rate. Current baud rate is baud rate.

See the Interactive Mode Commands section in Appendix E for correct command usage.

Cannot communicate with port port name.

Check this manual for supported ports. See the Port command.

Datafile file_name is empty.

The specified datafile is either empty or contains invalid data. JTAG Programmer supports only JEDEC 3-C format.

Datafile file_name is not found.

The file_name file does not exist in the current directory or search path. Check your environment search path to make sure that it contains the directory where file_name is.

Can't open datafile file_name.

The file file_name does not exist in the current directory or search path. Check your environment search path to make sure that it contains the directory where file_name is located.

No part type is defined.

The part type specified in your design or by you (using the Part command) is invalid. Check the The Programmable Logic Data Book for valid part types and packages.

Unable to execute erase command at address string of instance string.

The specified device instance could not be erased. Check if data protect is enabled as this disables the erase functionality. Also check for the integrity of the cable connections.

Unable to program all addresses of instance string.

The specified device instance could not be programmed. Check if data protect or data security is enabled as this disables the programming functionality. If data security is enabled, first issue an “erase” command then execute the program command. Also check for the integrity of the cable connections.

Verification of instance string against program file string failed.

The specified device instance could not be verified. Check if data security is enabled as this disables the readback functionality. If this is not the case, check for the integrity of the cable connections. If error persists you may have a bad part and Xilinx customer service should be contacted.

Unable to program address string of instance string with data string.

The specified device instance could not be programmed. Check if data protect or data security is enabled as this disables the programming functionality. If data security is enabled, first issue an “erase” command then execute the program command. Also check for the integrity of the cable connections.

Unable to verify address string of instance string against data string.

The specified device instance could not be verified. Check if data security is enabled as this disables the readback functionality. If this is not the case, check for the integrity of the cable connections. If error persists you may have a bad part and Xilinx customer service should be contacted.

Verification failed at address value of instance string. Expected: value. Read: value.

The specified device instance could not be verified. Check if data security is enabled as this disables the readback functionality. If this is not the case, check for the integrity of the cable connections. If error persists you may have a bad part and Xilinx customer service should be contacted.

A description for a device named string has not been supplied. Please make sure that a BSDL description was loaded for this device.

A description for an instance named string of any device has not been supplied. Please make sure that a JTAG connection description was supplied for this device.

Check that the specified part exists in the boundary-scan chain that you declared in your “part” command. A new “part” command will override the previously specified one. The current “part” database can be displayed by typing “part” followed by a carriage return.

The boundary scan chain instruction register bit sequence is incorrect at bit value. This corresponds to a scan chain break at or near part string.

Verification of the integrity of the boundary-scan chain failed. Check cable connections and “part” command specification The current “part” database can be displayed by typing “part” followed by a carriage return.

In a multi-part boundary scan chain, the name of the particular boundary scan part instance on which to operate must be specified. Please retry this command with an instance name specified.

You must specify a particular instance upon which to operated. Respecify the command with that information. That is, specify “erase instanceName” and not “erase”.

Unable to execute erase command for instance string

The specified device instance could not be erased. Check if data protect is enabled as this disables the erase functionality. Also check for the integrity of the cable connections.

Unable to execute functional test command using vectors in JEDEC file string.

Functional test vectors failed for instance string.

Functional test vector value failed for instance string at pin number value. Expected output value: value Actual output value: value

When running functional test using the INTEST instruction, the applied functional vectors mismatched the predicted values. This can be either a functional error in the design or an error in the vectors specified. This will also occur when vectors targetted for a different design are applied. Re-check the integrity of your design database information.

Mismatched address values during verification of instance string. Check JEDEC file and cable connections. Expected addressvalue: value. Read: value.

The specified device instance could not be verified. Check if data security is enabled as this disables the readback functionality. If this is not the case, check for the integrity of the cable connections. If error persists you may have a bad part and Xilinx customer service should be contacted.

Illegal IDCODE read from device identification register on instance string. IDCODE value: string

The IDCODE read from the specified part does not conform to the 1149.1 standard. This is often the result of a bad cable connection. Check the integrity of the cable connection.

Error reading data value from address string on device string while calculating checksum.

Data integrity errors while reading data values from device string will result in an incorrect checksum.

While reading back data to calculate the checksum, errors occurred. Check if data security is enabled as this disables the readback functionality. If this is not the case, check for the integrity of the cable connections. If error persists you may have a bad part and Xilinx customer service should be contacted.

Unable to program data protect bit at address string on device string.

Programming failures when programming data protect bits of device string.

Unable to program data security bit at address string on device string.

Programming failures when programming data security bits of device string.

The specified device instance could not be programmed. Check if data protect or data security is already enabled as this disables the programming functionality. If data security is enabled, first issue an "erase" command then execute the program command. Also check for the integrity of the cable connections.

Error reading data value from address string on device string while generating JEDEC file.

Data integrity errors while reading data values from device string will result in an incorrect or incomplete JEDEC file.

While reading back data to generate a JEDEC file, errors occurred.

Check if data security is enabled as this disables the readback functionality. If this is not the case, check for the integrity of the cable connections. If error persists you may have a bad part and Xilinx customer service should be contacted.

Xchecker configuration file for boundary-scan TAP driver not found. Check XILINX path setting and locate file named 'xckjtag.sys'.

When the Xchecker reconfiguration file xckjtag.sys is not found or loaded correctly the above messages are displayed. Check that your XILINX path includes the release "data" directory and that the file "xckjtag.sys" exists in it. Also, check the integrity of the connections to the xchecker cable both at the serial port and to the target system.

Data protection is enabled in instance string (NOTE: device programming contents cannot be altered).

This is the warning message issued when data protect is enabled. It is displayed with each operation addressing this device.

Data security is enabled in instance string (NOTE: device programming contents cannot be read).

This is the warning message issued when data security is enabled. It is displayed with each operation addressing this device.

The device string is not a Xilinx part (IDCODE: string)

The device string is not a XC9500 part (IDCODE: string) Please verify the specification of the order of the parts in the boundary-scan chain.

The device string is not an XC95108 part (IDCODE: string). Please verify the specification of the order of the parts in the boundary-scan chain.

The device string is not a currently supported XC9500 part (IDCODE: string) Please verify the specification of the order of the parts in the boundary-scan chain.

These messages are displayed when the software identifies that the specified operation is targetting an improper device. Check that the specified part exists in the boundary-scan chain that you declared in your "part" command. A new "part" command will override the

previously specified one. The current “part” database can be displayed by typing “part” followed by a carriage return.

The JEDEC file string is for a device of type string. The specified part string is actually a string device. Please re-generate your JEDEC file.

The specified part string is of type string for which JEDEC files cannot yet be generated.

These messages are displayed when the software identifies that the specified JEDEC file associated with an instance is not a supported device or does not match the specified device. Check that the specified part exists in the boundary-scan chain that you declared in your “part” command. A new “part” command will override the previously specified one. The current “part” database can be displayed by typing “part” followed by a carriage return.

The checksum calculated by reading the programmed device values differs from the expected result.

While reading back data to calculate the checksum, errors occurred. Check if data security is enabled as this disables the readback functionality. If this is not the case, check for the integrity of the cable connections. If error persists you may have a bad part and Xilinx customer service should be contacted.

Xchecker re-configuration file for boundary-scan TAP driver was not completed. Check XILINX path setting, cable connections and version of file named ‘xckjtag.sys’.

When the Xchecker reconfiguration file xckjtag.sys is not found or loaded correctly the above message is displayed. Check that your XILINX path includes the release “data” directory and that the file “xckjtag.sys” exists in it. Also, check the integrity of the connections to the xchecker cable both at the serial port and to the target system.

The device string is not an XC95216 part (IDCODE: string) Please verify the specification of the order of the parts in the boundary-scan chain.

This message is displayed when the software identifies that the specified operation is targeting an improper device. Check that the specified part exists in the boundary-scan chain that you declared in your “part” command. A new “part” command will override the previously specified one. The current “part” database can be displayed by typing “part” followed by a carriage return.

Using the Command Line Interface

This chapter gives specific information about using `jtagprog` in a workstation or PC environment to perform JTAG operations. You can use `jtagprog` to download, read back, verify design configuration data for any device, and to probe internal logic states of an CPLD design.

JTAG Programmer batch software support the following capabilities.

- JTAG Programmer allows you to download a design to the CPLD on the target system.
- JTAG Programmer can verify CPLD configuration by comparing it to the original JEDEC programming file after configuring an CPLD.
- You can program multiple CPLDs connected on a boundary-scan chain.
- You can apply test vectors from a JEDEC file through the boundary-scan TAP to CPLDs using the `INTEST` instruction.

This appendix contains the following sections:

- [Using JTAG Programmer Batch Version Software](#)
- [Command-Line Options](#)
- [Interactive Mode Commands](#)

Using JTAG Programmer Batch Version Software

This section describes the JTAG Programmer files and commands.

JTAG Programmer Files

You must become familiar with the following files, which are used by the JTAG Programmer software.

`design.jed`

The `design.jed` file contains the configuration information for the target design in JEDEC 3-C standard formats. The file is generated by the fitter software. This file may optionally contain functional test vectors to do functional verification of XC9500/XL/XV devices.

`jtagprogrammer.pro`

The `jtagprogrammer.pro` file contains the default values for all JTAG Programmer options: part, design, baud, and port. These option values are updated at the end of every JTAG Programmer session. For JTAG Programmer to recognize a `jtagprogrammer.pro` file, it must be located in the current working directory.

`batch_file.cmd`

The batch files are text files used to execute commands in the batch mode, and the extension “.cmd” is required.

`device.bsd`

The `bsd` files contain Boundary Scan Description Language (BSDL) specifications of the operation of the boundary-scan logic of a given device. For any non-XC9500/XL/XV device in your boundary-scan chain, you are required to supply this file.

Invoking JTAG Programmer

You can start JTAG Programmer using interactive commands from the system shell. This mode offers additional commands for download and readback and also allows you to probe the internal logic states of the target system device.

Downloading

You can download a design after connecting the cable to the host system and target system. To download a design, enter the following command at the operating system prompt.

`jtagprog`

When you do not specify any options, the JTAG Programmer software selects the port where the cable is connected and sets the baud rate to the maximum allowed by the platform. You can modify the communication port and baud rate by changing the appropriate settings in the `xchecker.pro` file.

To download in an interactive mode, enter the following command at the system prompt.

```
jtagprog
```

You see the following message on the screen:

```
JTAGProgrammer: version x1_1.0 Copyright: 1991-1996
```

```
Cable ID type is 'XCHECKER'  
Cable is connected to '/dev/ttya'  
Baud rate is 38400
```

To specify the number, type, names and order of devices in the boundary-scan chain:

```
part part_type:design_name
```

To erase and program the a design, enter this command string:

```
program design_name
```

Verifying

After you have properly configured a device, you can verify its configuration and compare it to your original design.

In most applications, verification is not needed, but this feature can be helpful with designs that experience extremely unstable or noisy VCC conditions.

To execute a readback after the device has been in operation, use the interactive commands, as follows:

```
jtagprog
```

This command invokes the interactive mode, and the `[JTAGProgrammer::(#)] >` prompt appears (the “#” in the prompt string is the current command number).

```
[JTAGProgrammer::(#)] > part part_type:design_name
```

The part commands identifies the number the number, type, name and order of devices in the boundary-scan chain. In this case there is one device only. Then to program the device, enter:

```
[JTAGProgrammer::(#)] > program design_name
```

The program command downloads design.jed to the target device. If you want a readback after the target device is in operation, you can execute the Verify command.

```
[JTAGProgrammer::(#)] > verify design_name
```

This command initiates a readback, and compares the data to the design.jed file.

You may also execute the program and verify operations in one step by typing:

```
[JTAGProgrammer::(#)] > program -v design_name
```

Command-Line Options

This section describes the JTAG Programmer command-line options. The data files are configuration bitstream files in JEDEC format. When you do not specify any options or data files, the system defaults to the interactive mode.

The command-line syntax is as follows:

```
jtagprog options
```

You can abbreviate all options to the minimum number of distinctive characters in the option name.

Commands and options are not case-sensitive.

-batch Batch Mode Operation

Syntax: `-batch bat_file.cmd`

Abbreviation: `b`

The Batch option executes commands in batch mode. The `bat_file` must have a ".cmd" extension and contain valid JTAG Programmer commands, including interactive commands. You can add comments to files by using the # symbol, either on the command line or on a new line.

-h The Help Option

Syntax: -help

Abbreviation: h

The Help option displays command line usage information.

-log Specify Log File Name

Syntax: -log filename.log

Abbreviation: -l

Captures all output to the specified log file.

-port Specify Port Name

Syntax: -port portname

Abbreviation: po

The Specify Port Name option identifies the port connection for the XChecker cable. If you do not specify this option, the default option AUTO, searches for the cable connected to any port, parallel or serial. Valid ports for supported platforms are listed in Table E-1.

Valid Ports for the XChecker Cable

| Platform | Communication Ports | | | |
|----------|---------------------|-------------|-------|-------|
| IBM PC | com1 | com2 | lpt1* | lpt2* |
| Sun | /dev/ttya** | /dev/ttyb** | | |
| HP | /dev/tty00 | /dev/tty01 | | |

*Use with the parallel download cable only.

**ttya and ttyb must be readable and writable to ensure a proper connection.

Interactive Mode Commands

This section describes the JTAG Programmer interactive mode commands. To use the interactive mode commands, you enter jtag-prog at the system prompt.

You can abbreviate the commands using the least number of distinctive characters, as with the command line options, but you must use at least two characters. You can repeat the previous command using either an equal sign, "=", or an exclamation point, "!".

Autoconfigure — Identify Chain Composition

Syntax: autoconfigure

Abbreviation: autoc

This command queries all the devices in the chain and attempts to identify the boundary-scan chain composition using the IDCODE instruction. The command returns a list of devices in the chain and their position with device 1 being closest to the system TDI. Parts that have not implemented IDCODE or those parts whose IDCODE is unrecognized will be identified as unknown devices.

Batch — Execute in Batch Mode

Syntax: batch bat_file.cmd

Abbreviation: bat

The Batch command executes commands in a batch mode. The bat_file must have a “.cmd” extension and contain valid JTAG Programmer commands. Use the pound sign, “#” to precede comment lines in the batch file.

Examples

The following examples show two methods of using the Batch command from the JTAG Programmer prompt:

```
batch bat_file.cmd
```

```
< bat_file.cmd
```

Baud — Specify Baud Rate

Syntax: baud baud_rate

Abbreviation: bau

The Baud command specifies a communication baud rate. At initialization, the fastest baud rate for your host system is automatically selected. Table E-2 lists the valid baud rates.

Valid Baud Rates

| Platform | Baud Rate | | |
|----------|-----------|-------|-------|
| | 9600 | 19200 | 38400 |
| IBM PC | X | X | X |
| Sun | X | X | X |
| HP 700 | X | X | X |

Dump

Syntax: `dump [-h] part_name -j file_name`

The dump command will read the contents of a part and create a JEDEC file with the results. The file created will default to `part_name.jed`. Optionally, you may specify your own name using the `-j` flag. The `part_name` must have been specified with the `part` command.

The `-h` flag specifies that all untargeted parts should use HIGHZ mode as the BYPASS method. This will float all untargeted device output pins and can reduce system noise in active environments.

Erase

Syntax: `erase [-f] [-h] part_name`

This command erases the programmed contents of the specified part. The `part_name` must have been specified with the `part` command. The option `-f` is used to reset write-protect.

The `-h` flag specifies that all untargeted parts should use HIGHZ mode as the BYPASS method. This will float all untargeted device output pins and can reduce system noise in active environments.

Exit — Terminate Session

Syntax: `exit`

Abbreviation: `exi`

The Exit command terminates the current JTAG Programmer session, asks you whether to save current program options in the `xchecker.pro` file, and returns you to the system shell.

Funcstest

Syntax: `funcstest [-h] part_name [-j file_name]`

The `funcstest` command will run the functional vectors in the associated JEDEC file (`file_name`) on the specified device (`part_name`) using the `intest` command. If the `part_name` is the same as the JEDEC `file_name`, then the `file_name` does not need to be specified. The `part_name` must have been specified with the `part` command.

The `-h` flag specifies that all untargeted parts should use HIGHZ mode as the BYPASS method. This will float all untargeted device output pins and can reduce system noise in active environments.

Help — Online Help

Syntax: `help topic`

Abbreviation: `he`

The `Help` command displays online help for the topic requested in 24-line segments. Enter `y` to scroll forward to the next 24 lines. Enter `n` to exit `Help`.

Id_loop — Idcode Looping

Syntax: `id_loop -n [number_of_loops] part_name`

This command is used to perform idcode looping to debug noise problems in the boundary scan chain.

Opgroup — Setup Group for Concurrent Operations

Syntax: `opgroup groupname partname:jedec_file`

This command is used to set up groups of devices for concurrent operations. Each group specified must have a unique name and can include any number of devices in the boundary-scan chain. The devices are identified by using the `partname` specified in the `part` command. You may optionally specify a full path name to the `jedec` file for each `partname`.

The `opgroup` command can be invoked only after a `part` command has been issued.

The groupname designated in the `opgroup` command can be used in place of the partname in the `erase`, `program` or `verify` commands to execute concurrent operations on all devices in that group.

Part — Specify Device Chain

Syntax: `part device_type:part_name device_type:part_name ...`

Abbreviation: `pa`

This command must be executed first. It describes the devices in the chain to the software. The `device_type` is used to find the BSDL file associated with each part. BSDL files must be named `device_type.bsd`. The `part_name` is an arbitrary name to associate with the device instance in the chain. It will usually be the proper name (the file name without the extension) of the JEDEC file associated with the device at that location in the boundary-scan chain, although it could be anything. The boundary scan chain order must start with the closest device to TDI, and proceed in order through the chain until it reaches the last device, which is closest to TDO. When multiple "part" commands are issued, the information associated with the very last is maintained.

Partinfo

Syntax: `partinfo [-h] -id -signature -checksum part_name -j jedec_file_name`

The `partinfo` command returns the manufacturer's identification (`id`), the user signature (`-signature`) or the device checksum (`-checksum`) for a particular `part_name`. Any or all of the three switches may be specified in a single command. The `part_name` must have been specified in the `part` command. When calculating the checksum the JEDEC file should be specified as well to indicate the expected checksum.

The `-h` flag specifies that all untargeted parts should use HIGHZ mode as the BYPASS method. This will float all untargeted device output pins and can reduce system noise in active environments.

If you use the `partinfo` command with the `-signature` option when generating an SVF file, use the `-u` option to specify the expected user-code.

Port — Specify Download/Readback Port

Syntax: port portname

Abbreviation: po

The port command specifies the download/readback port. Table 3-5 lists the valid entries; the ports listed in bold face are the defaults. If the port is defined as Auto, all ports are scanned to search for a cable.

Valid Ports for the Parallel, XChecker Cable and MultiLINX Cables

| Platform | Communication Ports | | | | |
|----------|---------------------|-------------|-------|-------|--------|
| IBM PC | com1 | com2 | lpt1* | lpt2* | usb*** |
| Sun | /dev/ttya** | /dev/ttyb** | | | |
| HP | /dev/tty00 | /dev/tty01 | | | |

*Use with the parallel download cable only.

**ttya and ttyb must be readable and writable to ensure a proper connection.

***only on Win98 Systems

Program

Syntax: program [-v] [-t] [-s] [-p] [-h] [-i] [-l] [-m] part_name [-j file_name]

This command programs the specified part. If the part_name is the same as the JEDEC file_name, then the file_name does not need to be specified. The part_name must have been set in the part command. There are four options that may be specified (individually or together):

-v after programming the device reads back the contents and verifies that they agree with the associated JEDEC file.

-t executes a functional test after programming using the vectors contained in the associated JEDEC file.

-s sets data security in the device. This disables readback of the device's programmed contents. The device must be erased to reprogram it.

-
- p sets data protect in the device. This disables over-write of the device's programmed contents. The device cannot be erased or re-programmed.
 - b skips the erase of the device prior to programming.
 - h specifies that all untargeted parts should use HIGHZ mode as the BYPASS method. This will float all untargeted device output pins and can reduce system noise in active environments.
 - i specifies info only. This is used with proms and indicates that only info bits are being programmed.
 - l loads FPGA. This is used to load FPGA at the end of configuration.
 - m selects map/parallel mode. This is used to configure the prom to seek out data in parallel mode.

Quit — Terminate Session

Syntax: quit

Abbreviation: qu

The Quit command terminates the current JTAG Programmer session and asks you whether to save current program options in the xchecker.pro file.

Save — Save Option Settings

Syntax: save

Abbreviation: sa

The Save command saves the settings of four interactive command results in the jtagprogrammer.pro file; baud rate (Baud command), design name (Load command), device type (Parttype command) and port name (Port command).

At initialization, JTAG Programmer reads the jtagprogrammer.pro file to set up the defaults for the current session. This file must be in the current directory or in the XILINX environment search path. JTAG Programmer updates the profile information at the end of every session. The jtagprogrammer.pro file is created when you exit from your first JTAG Programmer session.

Settings — Display Settings

Syntax: settings

Abbreviation: se

The Settings command provides a listing of the following information; the port name, the baud rate, the type of cable, the design name, the part type and package type, the clock source, and hardware trigger status. It also lists the number of clocks for the first and subsequent snapshots, the number of signals defined in the probe list, and the number of signals defined in the display list.

Sys — Temporarily Exit to Operating System

Syntax: sys

Abbreviation: none

The Sys command allows you to temporarily exit from JTAG Programmer to the operating system prompt. Enter exit to return to JTAG Programmer.

Verify — Verify Target CPLD Bitstream

Syntax: verify [-h] part_name [-j file_name]

Abbreviation: ve

This command reads back the configuration registers of the specified part and compares its contents against the JEDEC file. If the part_name is the same as the JEDEC file_name, the file_name does not need to be specified.

The -h flag specifies that all untargeted parts should use HIGHZ mode as the BYPASS method. This will float all untargeted device output pins and can reduce system noise in active environments.

Standard Methodologies for Instantiating the BSCAN Symbol

This appendix supplies examples for JTAG programming, including the following:

- [Instantiating the BSCAN symbol in Foundation XVHDL](#), which includes a solution for the XC5200 Family and the XC4000 Family
- [Instantiating the BSCAN symbol in Synplicity](#), which includes solutions for the XC5200 and XC4000 using Verilog and VHDL
- [Instantiating the BSCAN symbol in Synopsys](#), which includes examples for the XC5200 and XC4000 using Verilog and VHDL

Instantiating the BSCAN symbol in Foundation XVHDL

This section contains solutions for XC5200 and XC4000.

Solution 1 - XC5200 Family

The following example outlines instantiating the BSCAN symbol for XC5200 devices:

entity example is

port (a, b, c: in bit; d: out bit);

end example;

architecture xilinx of example is

component bscan

```
    port(tdi, tms, tck: in bit; tdo: out bit);
end component;
component tck
    port ( i : out bit );
end component;
component tdi
    port ( i : out bit );
end component;
component tms
    port ( i : out bit );
end component;
component tdo
    port ( o : in bit );
end component;
component ibuf
    port (i: in bit; o: out bit);
end component;
component obuf
    port(i: in bit; o: out bit);
end component;
signal tck_net, tck_net_in : bit;
signal tdi_net, tdi_net_in : bit;
signal tms_net, tms_net_in : bit;
signal tdo_net, tdo_net_out : bit;
begin
u1: bscan port map (tdi=>tdi_net, tms=>tms_net, tck=>tck_net,
tdo=>tdo_net_out);
u2: ibuf port map(i=>tck_net_in, o=>tck_net);
```

```

u3: ibuf port map(i=>tdi_net_in, o=>tdi_net);
u4: ibuf port map(i=>tms_net_in, o=>tms_net);
u5: obuf port map(i=>tdo_net_out, o=>tdo_net);
u6: tck port map (i=>tck_net_in);
u7: tdi port map (i=>tdi_net_in);
u8: tms port map (i=>tms_net_in);
u9: tdo port map (o=>tdo_net);
process(c)
begin
if(c'event and c='1') then
d <= a;
end if;
end process;
end xilinx;

```

Solution 2 - XC4000 Family

The following example outlines instantiation of the BSCAN symbol for XC4000 devices:

```

entity example is
    port (a, b, c: in bit; d: out bit);
end example;
architecture xilinx of example is
    component bscan
        port(tdi, tms, tck: in bit; tdo: out bit);
    end component;
    component tck
        port ( i : out bit);
    end component;
    component tdi

```

```
    port ( i : out bit );
end component;
component tms
    port ( i : out bit );
end component;
component tdo
    port ( o : in bit );
end component;
signal tck_net : bit;
signal tdi_net : bit;
signal tms_net : bit;
signal tdo_net : bit;
begin
u1: bscan port map (tdi=>tdi_net, tms=>tms_net, tck=>tck_net,
tdo=>tdo_net);
u2: tck port map (i=>tck_net);
u3: tdi port map (i=>tdi_net);
u4: tms port map (i=>tms_net);
u5: tdo port map (o=>tdo_net);
process(c)
begin
if(c'event and c='1') then
d <= a;
end if;
end process;
end xilinx;
```

Instantiating the BSCAN symbol in Synplicity

This section contains solutions for instantiating the BSCAN symbol in Synplicity.

Solution 1 - XC5200 Family - Verilog Code

```
// XC5200 - Boundary SCAN Verilog code
module bnd_scan (a, b, c, d);
input a, b, c;
output d;
reg d;
wire TCK_P, TDI_P, TMS_P, TDO_P;
BSCAN U0 (.TDO (TDO_P), .TDI (TDI_P), .TMS (TMS_P), .TCK
(TCK_P));
TDI U1 (.i (TDI_P));
TCK U2 (.i (TCK_P));
TMS U3 (.i (TMS_P));
TDO U4 (.o (TDO_P));
always@ (posedge c)
d<=a;
endmodule

module TDI(i) /* synthesis black_box */;
output i /* synthesis .ispad=1 */;
endmodule

module TCK(i) /*synthesis black_box*/;
output i /*synthesis .ispad=1*/;
endmodule

module TMS(i) /*synthesis black_box*/;
output i /*synthesis .ispad=1*/;
endmodule
```

```
module TDO(o) /*synthesis black_box .noprune=1 */;
input o /*synthesis .ispad=1*/;
endmodule

module BSCAN(TDO, TCK, TDI, TMS) /* synthesis black_box */;
output TDO;
input TCK, TDI, TMS;
endmodule

#-- TCL Script
#device options
set_option -technology XC5200
set_option -part XC5202
set_option -package PC84
set_option -speed_grade -3
#add_file options
add_file -verilog "bnd_scan.v"
#compilation/mapping options
set_option -default_enum_encoding onehot
set_option -symbolic_fsm_compiler true
#map options
set_option -frequency 0.000
set_option -fanout_limit 100
set_option -force_gsr true
set_option -disable_io_insertion false
set_option -xilinx_m1 true
#set result format/file last
project -result_file "bnd_scan.xnf"
project -run
#end TCL
```

Solution 2: Using the Synplicity Xilinx Macro Library

You can instantiate a BSCAN cell by using the import library supplied with Synplify. The Synplify Xilinx Macro Libraries contain pre-defined black-boxes for the Xilinx macros so that you can manually instantiate them into your design.

For VHDL based designs all one has to do is add the following 2 lines in the VHDL and instantiate the BSCAN component. Please look in the \$\$SYNPLCTY\lib\xilinxf000.vhd for BSCAN component and its port interface list. For xc5200 VHDL designs, use xc4000.vhd "black box" instantiation as an example.

```
library xc4000;  
use xc4000.components.all;
```

For Verilog designs, just add the xc4000.v file in the source file list along with the source design file. The xc4000.v file is also in the \$\$SYNPLCTY\lib\xilinx directory. For xc5200 Verilog designs, use xc4000.v black box instantiation as an example.

You must instantiate the complete set of Xilinx boundary scan modules (bscan,tdi,tck,tms,tdo) in to your design.

Solution 3: XC4000 Devices - Verilog Code

```
// XC4000e/ex/xl - Boundary SCAN Verilog code  
module bnd_scan (a, b, c, d);  
input a, b, c;  
output d;  
reg d;  
wire TCK_P, TDI_P, TMS_P, TDO_P;  
BSCAN U1 (.TDO (TDO_P), .TDI (TDI_P), .TMS (TMS_P), .TCK  
(TCK_P),  
        .DRCK (open), .IDLE (open), .SEL1 (open), .SEL2 (open),  
        .TDO1 (1'b0), .TDO2 (1'b0));  
TDI U2 (.i (TDI_P));  
TCK U3 (.i (TCK_P));
```

```
TMS U4 (.i (TMS_P));
TDO U5 (.o (TDO_P));
always@ (posedge c)
d<=a;
endmodule
#-- TCL script
#device options
set_option -technology XC4000E
set_option -part XC4003E
set_option -package PC84
set_option -speed_grade -1
#add_file options
add_file -verilog "/products/synplify.ver3_0/lib/xilinx/xc4000.v"
add_file -verilog "bnd_scan.v"
#map options
set_option -frequency 0.000
set_option -fanout_limit 100
set_option -force_gsr true
set_option -disable_io_insertion false
set_option -xilinx_m1 true
#set result format/file last
project -result_file "bnd_scan.xnf"
project -run
#end TCL
```

Solution 4: XC4000 Devices - VHDL Code

```
-- XC4000e/ex/xl - Boundary SCAN VHDL code
library IEEE;
```

```

use IEEE.std_logic_1164.all;
library xc4000;
use xc4000.components.all;
entity bnd_scan is
port (
a, b, c: in bit;
d: out bit
);
end bnd_scan;
architecture xilinx of bnd_scan is
signal TCK_P : STD_LOGIC;
signal TDI_P : STD_LOGIC;
signal TMS_P : STD_LOGIC;
signal TDO_P : STD_LOGIC;
begin
    U0: BSCAN port map (TDO => TDO_P,
        TDI => TDI_P,
        TMS => TMS_P,
        TCK => TCK_P,
        DRCK => open,
        IDLE => open,
        SEL1 => open,
        SEL2 => open,
        TDO1 => '0',
        TDO2 => '0');
    U1: TDI port map (I =>TDI_P);
    U2: TCK port map (I =>TCK_P);
    U3: TMS port map (I =>TMS_P);

```

```
    U4: TDO port map (O =>TDO_P);
process (c)
begin if (c'event and c='1')
    then d <= a;
end if;
end process;
end xilinx;
#-- TCL script
#device options
set_option -technology XC4000E
set_option -part XC4003E
set_option -package PC84
set_option -speed_grade -1
#add_file options
add_file -vhdl -lib work "bnd_scan.vhd"
add_file -_include "/products/synplify.ver3_0/lib/xilinx/
xc4000.vhd"
#compilation/mapping options
set_option -default_enum_encoding onehot
set_option -symbolic_fsm_compiler false
#map options
set_option -frequency 0.000
set_option -fanout_limit 100
set_option -force_gsr true
set_option -disable_io_insertion false
set_option -xilinx_m1 true
#set result format/file last
project -result_file "bnd_scan.xnf"
```

```
project -run
```

```
#end TCL
```

If you experience problems instantiating, the simplest workaround for you would be to replace the VHDL "open" statements with actual signal names. All you have to do is declare 4 signals of type `std_logic` and connect the DRCK, IDLE, SEL1 and SEL2 ports of BSCAN to these signals.

Another solution that would work requires a change in the BSCAN component declaration in the `xc4000.vhd` file located in your `SYNPLCTY\LIB\xilinx` directory.

Please change the BSCAN component to be component BSCAN

```
port(  
    TDO           : out  STD_LOGIC ;  
    DRCK          : out  STD_LOGIC ;  
    IDLE          : out  STD_LOGIC ;  
    SEL1          : out  STD_LOGIC ;  
    SEL2          : out  STD_LOGIC ;  
    TDI           : in   STD_LOGIC ;  
    TMS           : in   STD_LOGIC ;  
    TCK           : in   STD_LOGIC ;  
    TDO1          : in   STD_LOGIC ;  
    TDO2          : in   STD_LOGIC ;
```

```
end component;
```

Notice that the initialization for the output ports have been removed.

Solution 5: XC5200 Devices - VHDL Code

```
-- XC5200 - Boundary Scan VHDL code
```

```
library IEEE;
```

```
use IEEE.std_logic_1164.all;
```

```
entity bnd_scan is
```

```
port (a, b, c: in bit;
d: out bit);
end bnd_scan;
architecture xilinx of bnd_scan is
    attribute black_box : boolean;
    attribute black_box_pad_pin : string;
    attribute synthesis_noprune : boolean;
    component BSCAN
        port (TDI, TMS, TCK : in STD_LOGIC;
            TDO : out STD_LOGIC);
    end component;
    attribute black_box of BSCAN : component is true;
    component TDI
        port (I : out STD_LOGIC);
    end component;
    attribute black_box_pad_pin of TDI : component is "I";
    component TCK
        port (I : out STD_LOGIC);
    end component;
    attribute black_box_pad_pin of TCK : component is "I";
    component TMS
        port (I : out STD_LOGIC);
    end component;
    attribute black_box_pad_pin of TMS : component is "I";
    component TDO
        port (O : in STD_LOGIC);
    end component;
    attribute black_box_pad_pin of TDO : component is "O";
```

```

    attribute synthesis_noprune of TDO : component is true;
signal TCK_P : STD_LOGIC;
signal TDI_P : STD_LOGIC;
signal TMS_P : STD_LOGIC;
signal TDO_P : STD_LOGIC;
begin
    U0: BSCAN port map (TDO => TDO_P,
                       TDI => TDI_P,
                       TMS => TMS_P,
                       TCK => TCK_P);
    U1: TDI port map (I =>TDI_P);
    U2: TCK port map (I =>TCK_P);
    U3: TMS port map (I =>TMS_P);
    U4: TDO port map (O =>TDO_P);
process (c)
begin
if (c'event and c='1') then
d <= a;
end if;
end process;
end xilinx;
#-- TCL Script
#device options
set_option -technology XC5200
set_option -part XC5202
set_option -package PC84
set_option -speed_grade -3
#add_file options

```

```
add_file -vhdl -lib work "bnd_scan.vhd"
#compilation/mapping options
set_option -default_enum_encoding onehot
set_option -symbolic_fsm_compiler false
#map options
set_option -frequency 0.000
set_option -fanout_limit 100
set_option -force_gsr true
set_option -disable_io_insertion false
set_option -xilinx_m1 true
#set result format/file last
project -result_file "bnd_scan.xnf"
project -run
#end TCL
```

Instantiating the BSCAN symbol in Synopsys

This section contains solutions for instantiating the BSCAN symbol in Synopsys.

Solution 1: XC5200 Devices - VHDL Code

```
VHDL Code for Instantiating BSCAN in the XC5200:
-- XC5200 example of instantiating the BSCAN symbol
entity example is
    port (a, b, c: in bit; d: out bit);
end example;
architecture xilinx of example is
    component bscan
        port(tdi, tms, tck: in bit; tdo: out bit);
    end component;
```

```
component tck
  port ( i : out bit );
end component;
component tdi
  port ( i : out bit );
end component;
component tms
  port ( i : out bit );
end component;
component tdo
  port ( o : in bit );
end component;
component ibuf
  port (i: in bit; o: out bit);
end component;
component obuf
  port(i: in bit; o: out bit);
end component;
signal tck_net, tck_net_in : bit;
signal tdi_net, tdi_net_in : bit;
signal tms_net, tms_net_in : bit;
signal tdo_net, tdo_net_out : bit;
begin
u1: bscan port map (tdi=>tdi_net, tms=>tms_net, tck=>tck_net,
tdo=>tdo_net_out);
u2: ibuf port map(i=>tck_net_in, o=>tck_net);
u3: ibuf port map(i=>tdi_net_in, o=>tdi_net);
u4: ibuf port map(i=>tms_net_in, o=>tms_net);
```

```
u5: obuf port map(i=>tdo_net_out, o=>tdo_net);
u6: tck port map (i=>tck_net_in);
u7: tdi port map (i=>tdi_net_in);
u8: tms port map (i=>tms_net_in);
u9: tdo port map (o=>tdo_net);
process(c)
begin
if(c'event and c='1') then
d<= a;
end if;
end process;
end xilinx;
```

Runscript for compiling XC5200 BSCAN VHDL Example:

```
PART = 5202PC84-5
```

```
TOP = example
```

```
analyze -format vhdl "bscan5k.vhd"
```

```
elaborate TOP
```

```
set_port_is_pad "*"
```

```
insert_pads
```

```
set_dont_touch u1
```

```
set_dont_touch u2
```

```
set_dont_touch u3
```

```
set_dont_touch u4
```

```
set_dont_touch u5
```

```
set_dont_touch u6
```

```
set_dont_touch u7
```

```
set_dont_touch u8
```

```
set_dont_touch u9
```

```
compile
set_attribute TOP "part" -type string PART
write -f xnf -h -o "bscan5k.sxnf"
```

Solution 2: XC4000 Devices - Verilog Code

Verilog Code for Instantiating BSCAN in the XC4000

VERILOG IS CASE SENSITIVE! BE SURE TO FOLLOW THE CASE USED IN THIS EXAMPLE!

```
//XC4000/XC4000E Example of instantiating BSCAN symbol
```

```
module example (a,b,c,d);
input a, b, c;
output d;
reg d;
wire tck_net;
wire tdi_net;
wire tms_net;
wire tdo_net;
BSCAN u1 (.TDI(tdi_net), .TMS(tms_net), .TCK(tck_net),
.TDO(tdo_net));
TDI u2 (.I(tdi_net));
TMS u3 (.I(tms_net));
TCK u4 (.I(tck_net));
TDO u5 (.O(tdo_net));
always@(posedge c)
d<=a;
endmodule

Runscript for compiling XC4000 BSCAN Verilog Example:
PART = 4025ehq240-3
TOP = example
```

```
read -format verilog "bscan4k.v"
set_port_is_pad "*"
insert_pads
set_dont_touch u1
set_dont_touch u2
set_dont_touch u3
set_dont_touch u4
set_dont_touch u5
compile
replace_fpga
set_attribute TOP "part" -type string PART
write -f xnf -h -o "bscan4k.sxnf"
```

Solution 3: XC5200 Devices - Verilog Code

Verilog Code for Instantiating BSCAN in the XC5200:

```
//XC5200 Example of instantiating BSCAN symbol
module example (a,b,c,d);
input a, b, c;
output d;
reg d;
wire tck_net, tck_net_in;
wire tdi_net, tdi_net_in;
wire tms_net, tms_net_in;
wire tdo_net, tdo_net_out;
BSCAN u1 (.TDI(tdi_net), .TMS(tms_net), .TCK(tck_net),
.TDO(tdo_net));
TDI u2 (.I(tdi_net_in));
TMS u3 (.I(tms_net_in));
TCK u4 (.I(tck_net_in));
```

```
TDO u5 (.O(tdo_net_out));
IBUF u6 (.I(tdi_net_in), .O(tdi_net));
IBUF u7 (.I(tms_net_in), .O(tms_net));
IBUF u8 (.I(tck_net_in), .O(tck_net));
OBUF u9 (.I(tdo_net), .O(tdo_net_out));
always@(posedge c)
d<=a;
endmodule
```

Runscript for compiling XC5200 BSCAN Verilog Example:

```
PART = 5202PC84-5
```

```
TOP = example
```

```
read -format verilog "bscan5k.v"
```

```
set_port_is_pad "*"
```

```
insert_pads
```

```
set_dont_touch u1
```

```
set_dont_touch u2
```

```
set_dont_touch u3
```

```
set_dont_touch u4
```

```
set_dont_touch u5
```

```
set_dont_touch u6
```

```
set_dont_touch u7
```

```
set_dont_touch u8
```

```
set_dont_touch u9
```

```
compile
```

```
set_attribute TOP "part" -type string PART
```

```
write -f xnf -h -o "bscan5k.sxnf"
```

Solution 4: XC4000 Devices - VHDL Code

VHDL Code for Instantiating BSCAN in the XC4000:

-- XC4000/XC4000E example of instantiating the BSCAN symbol

entity example is

port (a, b, c: in bit; d: out bit);

end example;

architecture xilinx of example is

component bscan

port(tdi, tms, tck: in bit; tdo: out bit);

end component;

component tck

port (i : out bit);

end component;

component tdi

port (i : out bit);

end component;

component tms

port (i : out bit);

end component;

component tdo

port (o : in bit);

end component;

signal tck_net : bit;

signal tdi_net : bit;

signal tms_net : bit;

signal tdo_net : bit;

begin

u1: bscan port map (tdi=>tdi_net, tms=>tms_net, tck=>tck_net,

```
tdo=>tdo_net);
u2: tck port map (i=>tck_net);
u3: tdi port map (i=>tdi_net);
u4: tms port map (i=>tms_net);
u5: tdo port map (o=>tdo_net);
process(c)
begin
if(c'event and c='1') then
d<= a;
end if;
end process;
end xilinx;
Runscript for compiling XC4000 BSCAN VHDL Example:
PART = 4025EHQ240-3
TOP = example
analyze -format vhdl "bscan4k.vhd"
elaborate TOP
set_dont_touch u1
set_dont_touch u2
set_dont_touch u3
set_dont_touch u4
set_dont_touch u5
set_port_is_pad "*"
insert_pads
compile
replace_fpga
set_attribute TOP "part" -type string PART
write -f xnf -h -o "bscan4k.sxnf"
```

set_dont_touch/dont_touch are case-sensitive with respect to instance names.