

## Virtex-E Electrical Characteristics

### Definition of Terms

The status of data sheets is designated as Advance or Preliminary. These specifications are defined as follows:

**Advance:** Initial estimates based on simulation and/or extrapolation from other speed grades, devices, or families. Values are subject to change. Use as estimates, not for production.

**Preliminary:** Based on preliminary characterization. Further changes are not expected.

**Unmarked:** Data sheets not identified as either Advance or Preliminary are to be considered final.

All specifications are representative of worst-case supply voltage and junction temperature conditions. The parameters included are common to popular designs and typical applications. Contact the factory for design considerations requiring more detailed information.

All specifications are subject to change without notice.

## DC Characteristics

### Absolute Maximum Ratings

Symbol	Description <sup>(1)</sup>		Units
V <sub>CCINT</sub>	Internal Supply voltage relative to GND <sup>(2)</sup>	-0.5 to 2.0	V
V <sub>CCO</sub>	Supply voltage relative to GND	-0.5 to 4.0	V
V <sub>REF</sub>	Input Reference Voltage	-0.5 to 4.0	V
V <sub>IN</sub>	Input voltage relative to GND	-0.5 to 4.0	V
V <sub>TS</sub>	Voltage applied to 3-state output	-0.5 to 4.0	V
V <sub>CC</sub>	Longest Supply Voltage Rise Time from 0 V - 1.71 V	50	ms
T <sub>STG</sub>	Storage temperature (ambient)	-65 to +150	°C
T <sub>J</sub>	Junction temperature <sup>(3)</sup>	Plastic packages +125	°C

#### Notes:

- Stresses beyond those listed under Absolute Maximum Ratings can cause permanent damage to the device. These are stress ratings only, and functional operation of the device at these or any other conditions beyond those listed under Operating Conditions is not implied. Exposure to Absolute Maximum Ratings conditions for extended periods of time can affect device reliability.
- Xilinx recommends that all device power supplies (V<sub>CCINT</sub>, V<sub>CCO</sub>) be powered up simultaneously. Other power supply sequence options might result in higher than typical power-up currents.
- For soldering guidelines and thermal considerations, see the [Device Packaging](#) information on the Xilinx website.

### Recommended Operating Conditions

Symbol	Description		Min	Max	Units
V <sub>CCINT</sub>	Internal Supply voltage relative to GND, T <sub>J</sub> = 0 °C to +85 °C	Commercial	1.8 - 5%	1.8 + 5%	V
	Internal Supply voltage relative to GND, T <sub>J</sub> = -40 °C to +100 °C	Industrial	1.8 - 5%	1.8 + 5%	V
V <sub>CCO</sub>	Supply voltage relative to GND, T <sub>J</sub> = 0 °C to +85 °C	Commercial	1.2	3.6	V
	Supply voltage relative to GND, T <sub>J</sub> = -40 °C to +100 °C	Industrial	1.2	3.6	V
T <sub>IN</sub>	Input signal transition time			250	ns

## DC Characteristics Over Recommended Operating Conditions

Symbol	Description	Device	Min	Max	Units
$V_{DRINT}$	Data Retention $V_{CCINT}$ Voltage (below which configuration data might be lost)	All	1.5		V
$V_{DRIO}$	Data Retention $V_{CCO}$ Voltage (below which configuration data might be lost)	All	1.2		V
$I_{CCINTQ}$	Quiescent $V_{CCINT}$ supply current (Note 1)	XCV50E		200	mA
		XCV100E		200	mA
		XCV200E		300	mA
		XCV300E		300	mA
		XCV400E		300	mA
		XCV600E		400	mA
		XCV1000E		500	mA
		XCV1600E		500	mA
		XCV2000E		500	mA
		XCV2600E		TBD	
		XCV3200E		TBD	
$I_{CCOQ}$	Quiescent $V_{CCO}$ supply current (Note 1)	XCV50E		2	mA
		XCV100E		2	mA
		XCV200E		2	mA
		XCV300E		2	mA
		XCV400E		2	mA
		XCV600E		2	mA
		XCV1000E		2	mA
		XCV1600E		2	mA
		XCV2000E		2	mA
		XCV2600E		TBD	
		XCV3200E		TBD	
$I_L$	Input or output leakage current	All	-10	+10	$\mu$ A
$C_{IN}$	Input capacitance (sample tested)	BGA, PQ, HQ, packages		8	pF
$I_{RPU}$	Pad pull-up (when selected) @ $V_{in} = 0$ V, $V_{CCO} = 3.3$ V (sample tested)	All	Note 2	0.25	mA
$I_{RPD}$	Pad pull-down (when selected) @ $V_{in} = 3.6$ V (sample tested)		Note 2	0.25	mA

### Notes:

1. With no output current loads, no active input pull-up resistors, all I/O pins 3-stated and floating.
2. Internal pull-up and pull-down resistors guarantee valid logic levels at unconnected input pins. These pull-up and pull-down resistors do not guarantee valid logic levels when input pins are connected to other circuits.

## Power-On Power Supply Requirements

Xilinx FPGAs require a certain amount of supply current during power-on to insure proper device operation. The actual current consumed depends on the power-on ramp rate of the power supply. This is the time required to reach the nominal power supply voltage of the device<sup>1</sup> from 0 V. The fastest suggested ramp rate is 0 V to nominal voltage in 2 ms and the slowest allowed ramp rate is 0 V to nominal voltage in 50 ms.

Product (Commercial Grade)	Description <sup>2</sup>	Current Requirement <sup>3</sup>
XCV50E - XCV600E	Minimum required current supply	500 mA
XCV1000E - XCV2000E	Minimum required current supply	1 A
XCV2600E - XCV3200E	Minimum required current supply	TBD
Virtex-E Family, Industrial Grade	Minimum required current supply	2 A

### Notes:

- Ramp rate used for this specification is from 0 - 1.8 V dc. Peak current occurs on or near the internal power-on reset threshold and lasts for less than 3 ms.
- Devices are guaranteed to initialize properly with the minimum current available from the power supply as noted above.
- Larger currents might result if ramp rates are forced to be faster.

## DC Input and Output Levels

Values for  $V_{IL}$  and  $V_{IH}$  are recommended input voltages. Values for  $I_{OL}$  and  $I_{OH}$  are guaranteed over the recommended operating conditions at the  $V_{OL}$  and  $V_{OH}$  test points. Only selected standards are tested. These are chosen to ensure that all standards meet their specifications. The selected standards are tested at minimum  $V_{CCO}$  with the respective  $V_{OL}$  and  $V_{OH}$  voltage levels shown. Other standards are sample tested.

Input/Output Standard	$V_{IL}$		$V_{IH}$		$V_{OL}$	$V_{OH}$	$I_{OL}$	$I_{OH}$
	V, Min	V, Max	V, Min	V, Max	V, Max	V, Min	mA	mA
LVTTTL (Note 1)	-0.5	0.8	2.0	3.6	0.4	2.4	24	-24
LVCMS2	-0.5	0.7	1.7	2.7	0.4	1.9	12	-12
LVCMS18	-0.5	35% $V_{CCO}$	65% $V_{CCO}$	1.95	0.4	$V_{CCO} - 0.4$	8	-8
PCI, 3.3 V	-0.5	30% $V_{CCO}$	50% $V_{CCO}$	$V_{CCO} + 0.5$	10% $V_{CCO}$	90% $V_{CCO}$	Note 2	Note 2
GTL	-0.5	$V_{REF} - 0.05$	$V_{REF} + 0.05$	3.6	0.4	n/a	40	n/a
GTL+	-0.5	$V_{REF} - 0.1$	$V_{REF} + 0.1$	3.6	0.6	n/a	36	n/a
HSTL I	-0.5	$V_{REF} - 0.1$	$V_{REF} + 0.1$	3.6	0.4	$V_{CCO} - 0.4$	8	-8
HSTL III	-0.5	$V_{REF} - 0.1$	$V_{REF} + 0.1$	3.6	0.4	$V_{CCO} - 0.4$	24	-8
HSTL IV	-0.5	$V_{REF} - 0.1$	$V_{REF} + 0.1$	3.6	0.4	$V_{CCO} - 0.4$	48	-8
SSTL3 I	-0.5	$V_{REF} - 0.2$	$V_{REF} + 0.2$	3.6	$V_{REF} - 0.6$	$V_{REF} + 0.6$	8	-8
SSTL3 II	-0.5	$V_{REF} - 0.2$	$V_{REF} + 0.2$	3.6	$V_{REF} - 0.8$	$V_{REF} + 0.8$	16	-16
SSTL2 I	-0.5	$V_{REF} - 0.2$	$V_{REF} + 0.2$	3.6	$V_{REF} - 0.61$	$V_{REF} + 0.61$	7.6	-7.6
SSTL2 II	-0.5	$V_{REF} - 0.2$	$V_{REF} + 0.2$	3.6	$V_{REF} - 0.80$	$V_{REF} + 0.80$	15.2	-15.2
CTT	-0.5	$V_{REF} - 0.2$	$V_{REF} + 0.2$	3.6	$V_{REF} - 0.4$	$V_{REF} + 0.4$	8	-8
AGP	-0.5	$V_{REF} - 0.2$	$V_{REF} + 0.2$	3.6	10% $V_{CCO}$	90% $V_{CCO}$	Note 2	Note 2

### Notes:

- $V_{OL}$  and  $V_{OH}$  for lower drive currents are sample tested.
- Tested according to the relevant specifications.

## LVDS DC Specifications

DC Parameter	Symbol	Conditions	Min	Typ	Max	Units
Supply Voltage	$V_{CCO}$		2.375	2.5	2.625	V
Output High Voltage for Q and $\bar{Q}$	$V_{OH}$	$R_T = 100 \Omega$ across Q and $\bar{Q}$ signals	1.25	1.425	1.6	V
Output Low Voltage for Q and $\bar{Q}$	$V_{OL}$	$R_T = 100 \Omega$ across Q and $\bar{Q}$ signals	0.9	1.075	1.25	V
Differential Output Voltage (Q – $\bar{Q}$ ), Q = High ( $\bar{Q}$ – Q), $\bar{Q}$ = High	$V_{ODIFF}$	$R_T = 100 \Omega$ across Q and $\bar{Q}$ signals	250	350	450	mV
Output Common-Mode Voltage	$V_{OCM}$	$R_T = 100 \Omega$ across Q and $\bar{Q}$ signals	1.125	1.25	1.375	V
Differential Input Voltage (Q – $\bar{Q}$ ), Q = High ( $\bar{Q}$ – Q), $\bar{Q}$ = High	$V_{IDIFF}$	Common-mode input voltage = 1.25 V	100	350	NA	mV
Input Common-Mode Voltage	$V_{ICM}$	Differential input voltage = $\pm 350$ mV	0.2	1.25	2.2	V

Note: Refer to the Design Consideration section for termination schematics.

## LVPECL DC Specifications

These values are valid at the output of the source termination pack shown under **LVPECL**, with a  $100 \Omega$  differential load only. The  $V_{OH}$  levels are 200 mV below standard LVPECL levels and are compatible with devices tolerant of lower common-mode ranges. The following table summarizes the DC output specifications of LVPECL.

DC Parameter	Min	Max	Min	Max	Min	Max	Units
$V_{CCO}$	3.0		3.3		3.6		V
$V_{OH}$	1.8	2.11	1.92	2.28	2.13	2.41	V
$V_{OL}$	0.96	1.27	1.06	1.43	1.30	1.57	V
$V_{IH}$	1.49	2.72	1.49	2.72	1.49	2.72	V
$V_{IL}$	0.86	2.125	0.86	2.125	0.86	2.125	V
Differential Input Voltage	0.3	-	0.3	-	0.3	-	V

## Virtex-E Switching Characteristics

Testing of switching parameters is modeled after testing methods specified by MIL-M-38510/605. All devices are 100% functionally tested. Internal timing parameters are derived from measuring internal test patterns. Listed below are representative values. For more specific, more precise, and worst-case guaranteed data, use the values reported by the static timing analyzer (TRCE in the Xilinx Development System) and back-annotated to the simulation net list. All timing parameters assume worst-case operating conditions (supply voltage and junction temperature). Values apply to all Virtex-E devices unless otherwise noted.

### IOB Input Switching Characteristics

Input delays associated with the pad are specified for LVTTTL levels in [Table 1](#). For other standards, adjust the delays with the values shown in [IOB Input Switching Characteristics Standard Adjustments](#), page 7.

Table 1: IOB Input Switching Characteristics

Description <sup>2</sup>	Symbol	Device	Speed Grade <sup>1</sup>				Units
			Min <sup>3</sup>	-8	-7	-6	
<b>Propagation Delays</b>							
Pad to I output, no delay	$T_{IOPI}$	All	0.43	0.8	0.8	0.8	ns, max
Pad to I output, with delay	$T_{IOPID}$	XCV50E	0.51	1.0	1.0	1.0	ns, max
		XCV100E	0.51	1.0	1.0	1.0	ns, max
		XCV200E	0.51	1.0	1.0	1.0	ns, max
		XCV300E	0.51	1.0	1.0	1.0	ns, max
		XCV400E	0.51	1.0	1.0	1.0	ns, max
		XCV600E	0.51	1.0	1.0	1.0	ns, max
		XCV1000E	0.55	1.1	1.1	1.1	ns, max
		XCV1600E	0.55	1.1	1.1	1.1	ns, max
		XCV2000E	0.55	1.1	1.1	1.1	ns, max
		XCV2600E <sup>4</sup>	0.55	1.1	1.1	1.1	ns, max
XCV3200E <sup>4</sup>	0.55	1.1	1.1	1.1	ns, max		
Pad to output IQ via transparent latch, no delay	$T_{IOPLI}$	All	0.8	1.4	1.5	1.6	ns, max
Pad to output IQ via transparent latch, with delay	$T_{IOPLID}$	XCV50E	1.31	2.9	3.0	3.1	ns, max
		XCV100E	1.31	2.9	3.0	3.1	ns, max
		XCV200E	1.39	3.1	3.2	3.3	ns, max
		XCV300E	1.39	3.1	3.2	3.3	ns, max
		XCV400E	1.43	3.2	3.3	3.4	ns, max
		XCV600E	1.55	3.5	3.6	3.7	ns, max
		XCV1000E	1.55	3.5	3.6	3.7	ns, max
		XCV1600E	1.59	3.6	3.7	3.8	ns, max
		XCV2000E	1.59	3.6	3.7	3.8	ns, max
		XCV2600E <sup>4</sup>	1.59	3.6	3.7	3.8	ns, max
XCV3200E <sup>4</sup>	1.59	3.6	3.7	3.8	ns, max		

Table 1: IOB Input Switching Characteristics (Continued)

Description <sup>2</sup>	Symbol	Device	Speed Grade <sup>1</sup>				Units
			Min <sup>3</sup>	-8	-7	-6	
<b>Sequential Delays</b>							
Clock CLK to output IQ	$T_{IOCKIQ}$	All	0.18	0.4	0.7	0.7	ns, max
<b>Setup and Hold Times with respect to Clock at IOB Input Register</b>							
Pad, no delay	$T_{IOICKP}/$ $T_{IOICKP}$	All	0.69 / 0	1.3 / 0	1.4 / 0	1.5 / 0	ns, min
Pad, with delay	$T_{IOICKD}/$ $T_{IOICKPD}$	XCV50E	1.25 / 0	2.8 / 0	2.9 / 0	2.9 / 0	ns, min
		XCV100E	1.25 / 0	2.8 / 0	2.9 / 0	2.9 / 0	ns, min
		XCV200E	1.33 / 0	3.0 / 0	3.1 / 0	3.1 / 0	ns, min
		XCV300E	1.33 / 0	3.0 / 0	3.1 / 0	3.1 / 0	ns, min
		XCV400E	1.37 / 0	3.1 / 0	3.2 / 0	3.2 / 0	ns, min
		XCV600E	1.49 / 0	3.4 / 0	3.5 / 0	3.5 / 0	ns, min
		XCV1000E	1.49 / 0	3.4 / 0	3.5 / 0	3.5 / 0	ns, min
		XCV1600E	1.53 / 0	3.5 / 0	3.6 / 0	3.6 / 0	ns, min
		XCV2000E	1.53 / 0	3.5 / 0	3.6 / 0	3.6 / 0	ns, min
		XCV2600E <sup>4</sup>	1.53 / 0	3.5 / 0	3.6 / 0	3.6 / 0	ns, min
XCV3200E <sup>4</sup>	1.53 / 0	3.5 / 0	3.6 / 0	3.6 / 0	ns, min		
ICE input	$T_{IOICECK}/$ $T_{IOICKICE}$	All	0.28 / 0.0	0.55 / 0.01	0.7 / 0.01	0.7 / 0.01	ns, min
SR input (IFF, synchronous)	$T_{IOSRCKI}$	All	0.38	0.8	0.9	1.0	ns, min
<b>Set/Reset Delays</b>							
SR input to IQ (asynchronous)	$T_{IOSRIQ}$	All	0.54	1.1	1.2	1.4	ns, max
GSR to output IQ	$T_{GSRQ}$	All	3.88	7.6	8.5	9.7	ns, max

**Notes:**

1. A Zero "0" Hold Time listing indicates no hold time or a negative hold time. Negative values can not be guaranteed "best-case", but if a "0" is listed, there is no positive hold time.
2. Input timing  $t_i$  for LVTTTL is measured at 1.4 V. For other I/O standards, see [Table 3](#).
3. The numbers for Min are **Advance** specification numbers. See [Definition of Terms, page 1](#) for a description.
4. The numbers for XCV2600E and XCV3200E devices are **Preview** specification numbers for all speed grades.

## IOB Input Switching Characteristics Standard Adjustments

Description	Symbol	Standard	Speed Grade <sup>1</sup>				Units
			Min <sup>2</sup>	-8	-7	-6	
<b>Data Input Delay Adjustments</b>							
Standard-specific data input delay adjustments	$T_{ILVTTL}$	LVTTTL	0.0	0.0	0.0	0.0	ns
	$T_{ILVCMOS2}$	LVC MOS2	-0.02	0.0	0.0	0.0	ns
	$T_{ILVCMOS18}$	LVC MOS18	0.12	+0.20	+0.20	+0.20	ns
	$T_{ILVDS}$	LVDS	0.00	+0.15	+0.15	+0.15	ns
	$T_{ILVPECL}$	LVPECL	0.00	+0.15	+0.15	+0.15	ns
	$T_{IPCI33\_3}$	PCI, 33 MHz, 3.3 V	-0.05	+0.08	+0.08	+0.08	ns
	$T_{IPCI66\_3}$	PCI, 66 MHz, 3.3 V	-0.05	-0.11	-0.11	-0.11	ns
	$T_{IGTL}$	GTL	+0.10	+0.14	+0.14	+0.14	ns
	$T_{IGTLPLUS}$	GTL+	+0.06	+0.14	+0.14	+0.14	ns
	$T_{IHSTL}$	HSTL	+0.02	+0.04	+0.04	+0.04	ns
	$T_{ISSTL2}$	SSTL2	-0.04	+0.04	+0.04	+0.04	ns
	$T_{ISSTL3}$	SSTL3	-0.02	+0.04	+0.04	+0.04	ns
	$T_{ICTT}$	CTT	+0.01	+0.10	+0.10	+0.10	ns
	$T_{IAGP}$	AGP	-0.03	+0.04	+0.04	+0.04	ns

**Notes:**

1. Input timing *i* for LVTTTL is measured at 1.4 V. For other I/O standards, see [Table 3](#).
2. The numbers for Min are **Advance** product specification numbers. See [Definition of Terms, page 1](#) for a description.

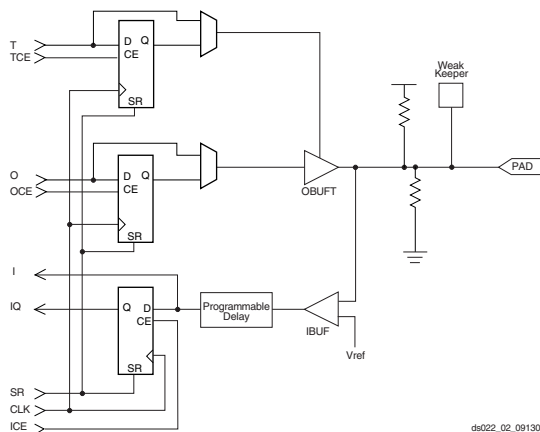

Figure 1: Virtex-E Input/Output Block (IOB)

## IOB Output Switching Characteristics, Figure 1

Output delays terminating at a pad are specified for LVTTTL with 12 mA drive and fast slew rate. For other standards, adjust the delays with the values shown in **IOB Output Switching Characteristics Standard Adjustments**, page 9.

Description <sup>(2)</sup>	Symbol	Speed Grade <sup>(1)</sup>				Units
		Min <sup>(3)</sup>	-8	-7	-6	
<b>Propagation Delays</b>						
O input to Pad	$T_{IOOP}$	1.04	2.5	2.7	2.9	ns, max
O input to Pad via transparent latch	$T_{IOOLP}$	1.24	2.9	3.1	3.4	ns, max
<b>3-State Delays</b>						
T input to Pad high-impedance (Note 2)	$T_{IOTHZ}$	0.73	1.5	1.7	1.9	ns, max
T input to valid data on Pad	$T_{IOTON}$	1.13	2.7	2.9	3.1	ns, max
T input to Pad high-impedance via transparent latch (Note 2)	$T_{IOTLPHZ}$	0.86	1.8	2.0	2.2	ns, max
T input to valid data on Pad via transparent latch	$T_{IOTLPON}$	1.26	3.0	3.2	3.4	ns, max
GTS to Pad high impedance (Note 2)	$T_{GTS}$	1.94	4.1	4.6	4.9	ns, max
<b>Sequential Delays</b>						
Clock CLK to Pad	$T_{IOCKP}$	0.97	2.4	2.8	2.9	ns, max
Clock CLK to Pad high-impedance (synchronous) (Note 2)	$T_{IOCKHZ}$	0.77	1.6	2.0	2.2	ns, max
Clock CLK to valid data on Pad (synchronous)	$T_{IOCKON}$	1.17	2.8	3.2	3.4	ns, max
<b>Setup and Hold Times before/after Clock CLK</b>						
O input	$T_{IOCKP} / T_{IOCKO}$	0.43 / 0	0.9 / 0	1.0 / 0	1.1 / 0	ns, min
OCE input	$T_{IOOCECK} / T_{IOCKOCE}$	0.28 / 0	0.55 / 0.01	0.7 / 0	0.7 / 0	ns, min
SR input (OFF)	$T_{IOSRCKO} / T_{IOCKOSR}$	0.40 / 0	0.8 / 0	0.9 / 0	1.0 / 0	ns, min
<b>3-State Setup Times, T input</b>	$T_{IOTCK} / T_{IOCKT}$	0.26 / 0	0.51 / 0	0.6 / 0	0.7 / 0	ns, min
<b>3-State Setup Times, TCE input</b>	$T_{IOTCECK} / T_{IOCKTCE}$	0.30 / 0	0.6 / 0	0.7 / 0	0.8 / 0	ns, min
<b>3-State Setup Times, SR input (TFF)</b>	$T_{IOSRCKT} / T_{IOCKTSR}$	0.38 / 0	0.8 / 0	0.9 / 0	1.0 / 0	ns, min
<b>Set/Reset Delays</b>						
SR input to Pad (asynchronous)	$T_{IOSRP}$	1.30	3.1	3.3	3.5	ns, max
SR input to Pad high-impedance (asynchronous) (Note 2)	$T_{IOSRHZ}$	1.08	2.2	2.4	2.7	ns, max
SR input to valid data on Pad (asynchronous)	$T_{IOSRON}$	1.48	3.4	3.7	3.9	ns, max
GSR to Pad	$T_{IOGSRQ}$	3.88	7.6	8.5	9.7	ns, max

### Notes:

1. A Zero "0" Hold Time listing indicates no hold time or a negative hold time. Negative values can not be guaranteed "best-case", but if a "0" is listed, there is no positive hold time.
2. 3-state turn-off delays should not be adjusted.
3. The numbers for Min are Advance product specification numbers. See **Definition of Terms**, page 1 for a description.



## IOB Output Switching Characteristics Standard Adjustments

Output delays terminating at a pad are specified for LVTTTL with 12 mA drive and fast slew rate. For other standards, adjust the delays by the values shown.

Description	Symbol	Standard	Speed Grade				Units
			Min <sup>1</sup>	-8	-7	-6	
<b>Output Delay Adjustments</b>							
Standard-specific adjustments for output delays terminating at pads (based on standard capacitive load, Csl)	T <sub>OLVTTL_S2</sub>	LVTTTL, Slow, 2 mA	4.2	+14.7	+14.7	+14.7	ns
	T <sub>OLVTTL_S4</sub>	4 mA	2.5	+7.5	+7.5	+7.5	ns
	T <sub>OLVTTL_S6</sub>	6 mA	1.8	+4.8	+4.8	+4.8	ns
	T <sub>OLVTTL_S8</sub>	8 mA	1.2	+3.0	+3.0	+3.0	ns
	T <sub>OLVTTL_S12</sub>	12 mA	1.0	+1.9	+1.9	+1.9	ns
	T <sub>OLVTTL_S16</sub>	16 mA	0.9	+1.7	+1.7	+1.7	ns
	T <sub>OLVTTL_S24</sub>	24 mA	0.8	+1.3	+1.3	+1.3	ns
	T <sub>OLVTTL_F2</sub>	LVTTTL, Fast, 2 mA	1.9	+13.1	+13.1	+13.1	ns
	T <sub>OLVTTL_F4</sub>	4 mA	0.7	+5.3	+5.3	+5.3	ns
	T <sub>OLVTTL_F6</sub>	6 mA	0.20	+3.1	+3.1	+3.1	ns
	T <sub>OLVTTL_F8</sub>	8 mA	0.10	+1.0	+1.0	+1.0	ns
	T <sub>OLVTTL_F12</sub>	12 mA	0.0	0.0	0.0	0.0	ns
	T <sub>OLVTTL_F16</sub>	16 mA	-0.10	-0.05	-0.05	-0.05	ns
	T <sub>OLVTTL_F24</sub>	24 mA	-0.10	-0.20	-0.20	-0.20	ns
	T <sub>OLVCMOS_2</sub>	LVC MOS2	0.10	+0.09	+0.09	+0.09	ns
	T <sub>OLVCMOS_18</sub>	LVC MOS18	0.10	+0.7	+0.7	+0.7	ns
	T <sub>OLVDS</sub>	LVDS	-0.39	-1.2	-1.2	-1.2	ns
	T <sub>OLVPECL</sub>	LVPECL	-0.20	-0.41	-0.41	-0.41	ns
	T <sub>OPCI33_3</sub>	PCI, 33 MHz, 3.3 V	0.50	+2.3	+2.3	+2.3	ns
	T <sub>OPCI66_3</sub>	PCI, 66 MHz, 3.3 V	0.10	-0.41	-0.41	-0.41	ns
	T <sub>OGTL</sub>	GTL	0.6	+0.49	+0.49	+0.49	ns
	T <sub>OGTLP</sub>	GTL+	0.7	+0.8	+0.8	+0.8	ns
	T <sub>OHSTL_I</sub>	HSTL I	0.10	-0.51	-0.51	-0.51	ns
	T <sub>OHSTL_III</sub>	HSTL III	-0.10	-0.91	-0.91	-0.91	ns
	T <sub>OHSTL_IV</sub>	HSTL IV	-0.20	-1.01	-1.01	-1.01	ns
	T <sub>OSSTL2_I</sub>	SSTL2 I	-0.10	-0.51	-0.51	-0.51	ns
	T <sub>OSSTL2_II</sub>	SSTL2 II	-0.20	-0.91	-0.91	-0.91	ns
T <sub>OSSTL3_I</sub>	SSTL3 I	-0.20	-0.51	-0.51	-0.51	ns	
T <sub>OSSTL3_II</sub>	SSTL3 II	-0.30	-1.01	-1.01	-1.01	ns	
T <sub>OCTT</sub>	CTT	0.0	-0.61	-0.61	-0.61	ns	
T <sub>OAGP</sub>	AGP	-0.1	-0.91	-0.91	-0.91	ns	

### Notes:

- The numbers for Min are Advance product specification numbers. See [Definition of Terms, page 1](#) for a description.

## Calculation of $T_{i\text{oop}}$ as a Function of Capacitance

$T_{i\text{oop}}$  is the propagation delay from the O Input of the IOB to the pad. The values for  $T_{i\text{oop}}$  are based on the standard capacitive load ( $C_{\text{sl}}$ ) for each I/O standard as listed in [Table 2](#).

**Table 2: Constants for Use in Calculation of  $T_{i\text{oop}}$**

Standard	Csl (pF)	fl (ns/pF)
LVTTL Fast Slew Rate, 2mA drive	35	0.41
LVTTL Fast Slew Rate, 4mA drive	35	0.20
LVTTL Fast Slew Rate, 6mA drive	35	0.13
LVTTL Fast Slew Rate, 8mA drive	35	0.079
LVTTL Fast Slew Rate, 12mA drive	35	0.044
LVTTL Fast Slew Rate, 16mA drive	35	0.043
LVTTL Fast Slew Rate, 24mA drive	35	0.033
LVTTL Slow Slew Rate, 2mA drive	35	0.41
LVTTL Slow Slew Rate, 4mA drive	35	0.20
LVTTL Slow Slew Rate, 6mA drive	35	0.10
LVTTL Slow Slew Rate, 8mA drive	35	0.086
LVTTL Slow Slew Rate, 12mA drive	35	0.058
LVTTL Slow Slew Rate, 16mA drive	35	0.050
LVTTL Slow Slew Rate, 24mA drive	35	0.048
LVCOS2	35	0.041
LVCOS18	35	0.050
PCI 33 MHz 3.3 V	10	0.050
PCI 66 MHz 3.3 V	10	0.033
GTL	0	0.014
GTL+	0	0.017
HSTL Class I	20	0.022
HSTL Class III	20	0.016
HSTL Class IV	20	0.014
SSTL2 Class I	30	0.028
SSTL2 Class II	30	0.016
SSTL3 Class I	30	0.029
SSTL3 Class II	30	0.016
CTT	20	0.035
AGP	10	0.037

### Notes:

- I/O parameter measurements are made with the capacitance values shown above. See the **Application Examples** (Module 2) for appropriate terminations.
- I/O standard measurements are reflected in the IBIS model information except where the IBIS format precludes it.

For other capacitive loads, use the formulas below to calculate the corresponding  $T_{i\text{oop}}$ :

$$T_{i\text{oop}} = T_{i\text{oop}} + T_{\text{opadjust}} + (C_{\text{load}} - C_{\text{sl}}) * fl$$

where:

$T_{\text{opadjust}}$  is reported above in the Output Delay Adjustment section.

$C_{\text{load}}$  is the capacitive load for the design.

**Table 3: Delay Measurement Methodology**

Standard	$V_L^1$	$V_H^1$	Meas. Point	$V_{\text{REF}}$ (Typ) <sup>2</sup>
LVTTL	0	3	1.4	-
LVCOS2	0	2.5	1.125	-
PCI33_3	Per PCI Spec			-
PCI66_3	Per PCI Spec			-
GTL	$V_{\text{REF}} - 0.2$	$V_{\text{REF}} + 0.2$	$V_{\text{REF}}$	0.80
GTL+	$V_{\text{REF}} - 0.2$	$V_{\text{REF}} + 0.2$	$V_{\text{REF}}$	1.0
HSTL Class I	$V_{\text{REF}} - 0.5$	$V_{\text{REF}} + 0.5$	$V_{\text{REF}}$	0.75
HSTL Class III	$V_{\text{REF}} - 0.5$	$V_{\text{REF}} + 0.5$	$V_{\text{REF}}$	0.90
HSTL Class IV	$V_{\text{REF}} - 0.5$	$V_{\text{REF}} + 0.5$	$V_{\text{REF}}$	0.90
SSTL3 I & II	$V_{\text{REF}} - 1.0$	$V_{\text{REF}} + 1.0$	$V_{\text{REF}}$	1.5
SSTL2 I & II	$V_{\text{REF}} - 0.75$	$V_{\text{REF}} + 0.75$	$V_{\text{REF}}$	1.25
CTT	$V_{\text{REF}} - 0.2$	$V_{\text{REF}} + 0.2$	$V_{\text{REF}}$	1.5
AGP	$V_{\text{REF}} - (0.2 \times V_{\text{CCO}})$	$V_{\text{REF}} + (0.2 \times V_{\text{CCO}})$	$V_{\text{REF}}$	Per AGP Spec
LVDS	1.2 - 0.125	1.2 + 0.125	1.2	
LVPECL	1.6 - 0.3	1.6 + 0.3	1.6	

### Notes:

- Input waveform switches between  $V_L$  and  $V_H$ .
- Measurements are made at  $V_{\text{REF}}$  (Typ), Maximum, and Minimum. Worst-case values are reported.  
I/O parameter measurements are made with the capacitance values shown in Table 14. See the **Application Examples** (Module 2) for appropriate terminations.  
I/O standard measurements are reflected in the IBIS model information except where the IBIS format precludes it.

## Clock Distribution Switching Characteristics

Description	Symbol	Speed Grade				Units
		Min <sup>1</sup>	-8	-7	-6	
<b>GCLK IOB and Buffer</b>						
Global Clock PAD to output.	T <sub>GPI0</sub>	0.38	0.7	0.7	0.7	ns, max
Global Clock Buffer I input to O output	T <sub>GIO</sub>	0.11	0.20	0.45	0.50	ns, max

**Notes:**

- The numbers for Min are **Advance** product specification numbers. See **Definition of Terms, page 1** for a description.

## I/O Standard Global Clock Input Adjustments

Description	Symbol <sup>1</sup>	Standard	Speed Grade				Units
			Min <sup>2</sup>	-8	-7	-6	
<b>Data Input Delay Adjustments</b>							
Standard-specific global clock input delay adjustments	T <sub>GPLVTTL</sub>	LVTTTL	0.0	0.0	0.0	0.0	ns, max
	T <sub>GPLVCMOS2</sub>	LVCOS2	-0.02	0.0	0.0	0.0	ns, max
	T <sub>GPLVCMOS18</sub>	LVCOS18	0.12	0.20	0.20	0.20	ns, max
	T <sub>GLVDS</sub>	LVDS	0.23	0.38	0.38	0.38	ns, max
	T <sub>GLVPECL</sub>	LVPECL	0.23	0.38	0.38	0.38	ns, max
	T <sub>GPCCI33_3</sub>	PCI, 33 MHz, 3.3 V	-0.05	0.08	0.08	0.08	ns, max
	T <sub>GPCCI66_3</sub>	PCI, 66 MHz, 3.3 V	-0.05	-0.11	-0.11	-0.11	ns, max
	T <sub>GPGTL</sub>	GTL	0.20	0.37	0.37	0.37	ns, max
	T <sub>GPGTLP</sub>	GTL+	0.20	0.37	0.37	0.37	ns, max
	T <sub>GPHSTL</sub>	HSTL	0.18	0.27	0.27	0.27	ns, max
	T <sub>GPSSTL2</sub>	SSTL2	0.21	0.27	0.27	0.27	ns, max
	T <sub>GPSSTL3</sub>	SSTL3	0.18	0.27	0.27	0.27	ns, max
	T <sub>GPCTT</sub>	CTT	0.22	0.33	0.33	0.33	ns, max
	T <sub>GPAGP</sub>	AGP	0.21	0.27	0.27	0.27	ns, max

**Notes:**

- Input timing for GPLVTTL is measured at 1.4 V. For other I/O standards, see **Table 3**.
- The numbers for Min are **Advance** product specification numbers. See **Definition of Terms, page 1** for a description.

## CLB Switching Characteristics

Delays originating at F/G inputs vary slightly according to the input used, see [Figure 2](#). The values listed below are worst-case. Precise values are provided by the timing analyzer.

Description	Symbol	Speed Grade <sup>(1)</sup>				Units
		Min <sup>(2)</sup>	-8	-7	-6	
<b>Combinatorial Delays</b>						
4-input function: F/G inputs to X/Y outputs	$T_{ILO}$	0.19	0.40	0.42	0.47	ns, max
5-input function: F/G inputs to F5 output	$T_{IF5}$	0.36	0.76	0.8	0.9	ns, max
5-input function: F/G inputs to X output	$T_{IF5X}$	0.35	0.74	0.8	0.9	ns, max
6-input function: F/G inputs to Y output via F6 MUX	$T_{IF6Y}$	0.35	0.74	0.9	1.0	ns, max
6-input function: F5IN input to Y output	$T_{F5INY}$	0.04	0.11	0.20	0.22	ns, max
Incremental delay routing through transparent latch to XQ/YQ outputs	$T_{IFNCTL}$	0.27	0.63	0.7	0.8	ns, max
BY input to YB output	$T_{BYYB}$	0.19	0.38	0.46	0.51	ns, max
<b>Sequential Delays</b>						
FF Clock CLK to XQ/YQ outputs	$T_{CKO}$	0.34	0.87	0.9	1.0	ns, max
Latch Clock CLK to XQ/YQ outputs	$T_{CKLO}$	0.40	0.87	0.9	1.0	ns, max
<b>Setup and Hold Times before/after Clock CLK</b>						
4-input function: F/G Inputs	$T_{ICK} / T_{CKI}$	0.39 / 0	0.9 / 0	1.0 / 0	1.1 / 0	ns, min
5-input function: F/G inputs	$T_{IF5CK} / T_{CKIF5}$	0.55 / 0	1.3 / 0	1.4 / 0	1.5 / 0	ns, min
6-input function: F5IN input	$T_{F5INCK} / T_{CKF5IN}$	0.27 / 0	0.6 / 0	0.8 / 0	0.8 / 0	ns, min
6-input function: F/G inputs via F6 MUX	$T_{IF6CK} / T_{CKIF6}$	0.58 / 0	1.3 / 0	1.5 / 0	1.6 / 0	ns, min
BX/BY inputs	$T_{DICK} / T_{CKDI}$	0.25 / 0	0.6 / 0	0.7 / 0	0.8 / 0	ns, min
CE input	$T_{CECK} / T_{CKCE}$	0.28 / 0	0.55 / 0	0.7 / 0	0.7 / 0	ns, min
SR/BY inputs (synchronous)	$T_{RCK} / T_{CKR}$	0.24 / 0	0.46 / 0	0.52 / 0	0.6 / 0	ns, min
<b>Clock CLK</b>						
Minimum Pulse Width, High	$T_{CH}$	0.56	1.2	1.3	1.4	ns, min
Minimum Pulse Width, Low	$T_{CL}$	0.56	1.2	1.3	1.4	ns, min
<b>Set/Reset</b>						
Minimum Pulse Width, SR/BY inputs	$T_{RPW}$	0.94	1.9	2.1	2.4	ns, min
Delay from SR/BY inputs to XQ/YQ outputs (asynchronous)	$T_{RQ}$	0.39	0.8	0.9	1.0	ns, max
Toggle Frequency (MHz) (for export control)	$F_{TOG}$	-	416	400	357.2	MHz

### Notes:

1. A Zero "0" Hold Time listing indicates no hold time or a negative hold time. Negative values can not be guaranteed "best-case", but if a "0" is listed, there is no positive hold time.
2. The numbers for Min are **Advance** product specification numbers. See [Definition of Terms, page 1](#) for a description.

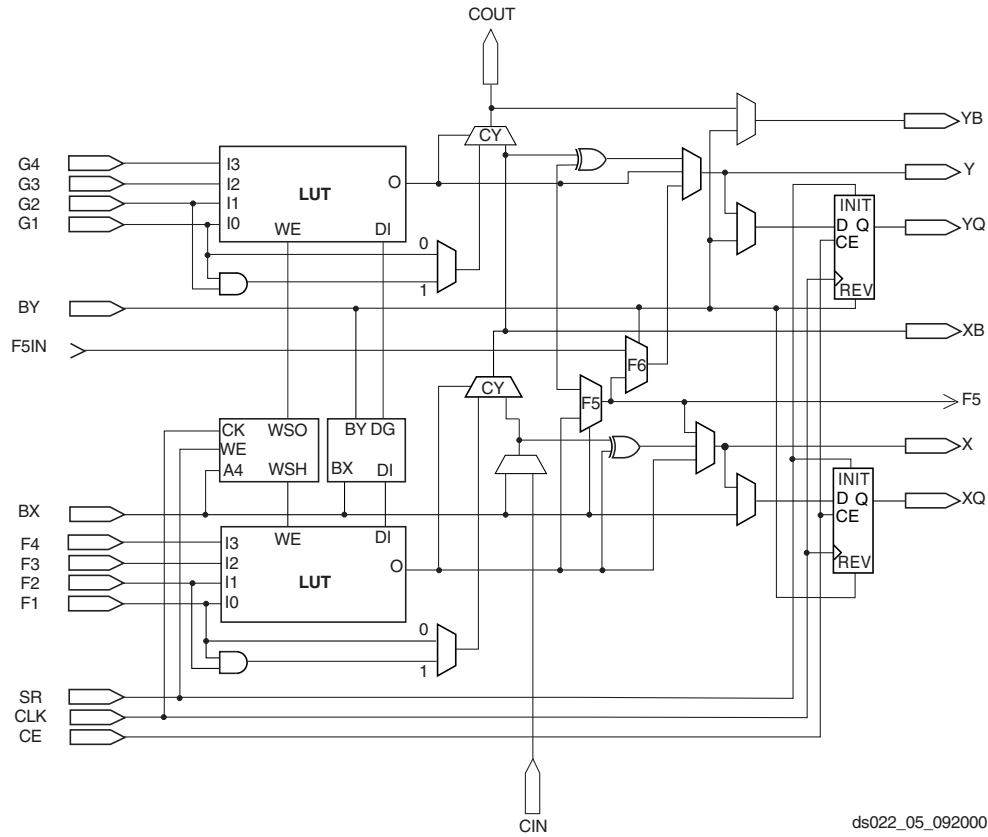

Figure 2: Detailed View of Virtex-E Slice

ds022\_05\_092000

## CLB Arithmetic Switching Characteristics

Setup times not listed explicitly can be approximated by decreasing the combinatorial delays by the setup time adjustment listed. Precise values are provided by the timing analyzer.

Description	Symbol	Speed Grade <sup>1</sup>				Units
		Min <sup>2</sup>	-8	-7	-6	
<b>Combinatorial Delays</b>						
F operand inputs to X via XOR	$T_{OPX}$	0.32	0.68	0.8	0.8	ns, max
F operand input to XB output	$T_{OPXB}$	0.35	0.65	0.8	0.9	ns, max
F operand input to Y via XOR	$T_{OPY}$	0.59	1.06	1.4	1.5	ns, max
F operand input to YB output	$T_{OPYB}$	0.48	0.89	1.1	1.3	ns, max
F operand input to COUT output	$T_{OPCYF}$	0.37	0.71	0.9	1.0	ns, max
G operand inputs to Y via XOR	$T_{OPGY}$	0.34	0.72	0.8	0.9	ns, max
G operand input to YB output	$T_{OPGYB}$	0.47	0.78	1.2	1.3	ns, max
G operand input to COUT output	$T_{OPCYG}$	0.36	0.60	0.9	1.0	ns, max
BX initialization input to COUT	$T_{BXCX}$	0.19	0.36	0.51	0.57	ns, max
CIN input to X output via XOR	$T_{CINX}$	0.27	0.50	0.6	0.7	ns, max
CIN input to XB	$T_{CINXB}$	0.02	0.03	0.07	0.08	ns, max
CIN input to Y via XOR	$T_{CINY}$	0.26	0.45	0.7	0.7	ns, max
CIN input to YB	$T_{CINYB}$	0.16	0.28	0.38	0.43	ns, max
CIN input to COUT output	$T_{BYP}$	0.05	0.10	0.14	0.15	ns, max
<b>Multiplier Operation</b>						
F1/2 operand inputs to XB output via AND	$T_{FANDXB}$	0.10	0.30	0.35	0.39	ns, max
F1/2 operand inputs to YB output via AND	$T_{FANDYB}$	0.28	0.56	0.7	0.8	ns, max
F1/2 operand inputs to COUT output via AND	$T_{FANDCY}$	0.17	0.38	0.46	0.51	ns, max
G1/2 operand inputs to YB output via AND	$T_{GANDYB}$	0.20	0.46	0.55	0.7	ns, max
G1/2 operand inputs to COUT output via AND	$T_{GANDCY}$	0.09	0.28	0.30	0.34	ns, max
<b>Setup and Hold Times before/after Clock CLK</b>						
CIN input to FFX	$T_{CCKX}/T_{CKCX}$	0.47 / 0	1.0 / 0	1.2 / 0	1.3 / 0	ns, min
CIN input to FFY	$T_{CCKY}/T_{CKCY}$	0.49 / 0	0.92 / 0	1.2 / 0	1.3 / 0	ns, min

### Notes:

1. A Zero "0" Hold Time listing indicates no hold time or a negative hold time. Negative values can not be guaranteed "best-case", but if a "0" is listed, there is no positive hold time.
2. The numbers for Min are **Advance** product specification numbers. See **Definition of Terms**, page 1 for a description.

### CLB Distributed RAM Switching Characteristics

Description	Symbol	Speed Grade <sup>1</sup>				Units
		Min <sup>2</sup>	-8	-7	-6	
<b>Sequential Delays</b>						
Clock CLK to X/Y outputs (WE active) 16 x 1 mode	T <sub>SHCKO16</sub>	0.67	1.48	1.5	1.7	ns, max
Clock CLK to X/Y outputs (WE active) 32 x 1 mode	T <sub>SHCKO32</sub>	0.84	1.76	1.9	2.1	ns, max
<b>Shift-Register Mode</b>						
Clock CLK to X/Y outputs	T <sub>REG</sub>	1.25	2.49	2.9	3.2	ns, max
<b>Setup and Hold Times before/after Clock CLK</b>						
F/G address inputs	T <sub>AS</sub> /T <sub>AH</sub>	0.19 / 0	0.38 / 0	0.42 / 0	0.47 / 0	ns, min
BX/BY data inputs (DIN)	T <sub>DS</sub> /T <sub>DH</sub>	0.24 / 0	0.47 / 0	0.53 / 0	0.6 / 0	ns, min
CE input (WE)	T <sub>WS</sub> /T <sub>WH</sub>	0.29 / 0	0.57 / 0	0.7 / 0	0.8 / 0	ns, min
<b>Shift-Register Mode</b>						
BX/BY data inputs (DIN)	T <sub>SHDICK</sub>	0.24 / 0	0.47 / 0	0.53 / 0	0.6 / 0	ns, min
CE input (WS)	T <sub>SHCHECK</sub>	0.29 / 0	0.57 / 0	0.7 / 0	0.8 / 0	ns, min
<b>Clock CLK</b>						
Minimum Pulse Width, High	T <sub>WPH</sub>	0.96	1.9	2.1	2.4	ns, min
Minimum Pulse Width, Low	T <sub>WPL</sub>	0.96	1.9	2.1	2.4	ns, min
Minimum clock period to meet address write cycle time	T <sub>WC</sub>	1.92	3.8	4.2	4.8	ns, min
<b>Shift-Register Mode</b>						
Minimum Pulse Width, High	T <sub>SRPH</sub>	1.0	1.9	2.1	2.4	ns, min
Minimum Pulse Width, Low	T <sub>SRPL</sub>	1.0	1.9	2.1	2.4	ns, min

**Notes:**

1. A Zero "0" Hold Time listing indicates no hold time or a negative hold time. Negative values can not be guaranteed "best-case", but if a "0" is listed, there is no positive hold time.
2. The numbers for Min are **Advance** product specification numbers. See **Definition of Terms, page 1** for a description.

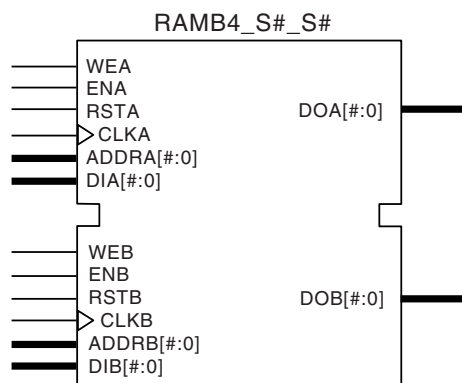

ds022\_06\_121699

Figure 3: Dual-Port Block SelectRAM

## Block RAM Switching Characteristics

Description	Symbol	Speed Grade <sup>1</sup>				Units
		Min <sup>2</sup>	-8	-7	-6	
<b>Sequential Delays</b>						
Clock CLK to DOUT output	$T_{BCKO}$	0.63	2.46	3.1	3.5	ns, max
<b>Setup and Hold Times before Clock CLK</b>						
ADDR inputs	$T_{BACK}/T_{BCKA}$	0.42 / 0	0.9 / 0	1.0 / 0	1.1 / 0	ns, min
DIN inputs	$T_{BDCK}/T_{BCKD}$	0.42 / 0	0.9 / 0	1.0 / 0	1.1 / 0	ns, min
EN input	$T_{BECK}/T_{BCKE}$	0.97 / 0	2.0 / 0	2.2 / 0	2.5 / 0	ns, min
RST input	$T_{BRCK}/T_{BCKR}$	0.9 / 0	1.8 / 0	2.1 / 0	2.3 / 0	ns, min
WEN input	$T_{BWCK}/T_{BCKW}$	0.86 / 0	1.7 / 0	2.0 / 0	2.2 / 0	ns, min
<b>Clock CLK</b>						
Minimum Pulse Width, High	$T_{BPWH}$	0.6	1.2	1.35	1.5	ns, min
Minimum Pulse Width, Low	$T_{BPWL}$	0.6	1.2	1.35	1.5	ns, min
CLKA -> CLKB setup time for different ports	$T_{BCCS}$	1.2	2.4	2.7	3.0	ns, min

### Notes:

1. A Zero "0" Hold Time listing indicates no hold time or a negative hold time. Negative values can not be guaranteed "best-case", but if a "0" is listed, there is no positive hold time.
2. The numbers for Min are **Advance** product specification numbers. See **Definition of Terms**, page 1 for a description.

## TBUF Switching Characteristics

Description	Symbol	Speed Grade				Units
		Min <sup>1</sup>	-8	-7	-6	
<b>Combinatorial Delays</b>						
IN input to OUT output	$T_{IO}$	0.0	0.0	0.0	0.0	ns, max
TRI input to OUT output high-impedance	$T_{OFF}$	0.05	0.092	0.10	0.11	ns, max
TRI input to valid data on OUT output	$T_{ON}$	0.05	0.092	0.10	0.11	ns, max

### Notes:

1. The numbers for Min are **Advance** product specification numbers. See **Definition of Terms**, page 1 for a description.

## JTAG Test Access Port Switching Characteristics

Description	Symbol	Value	Units
TMS and TDI Setup times before TCK	$T_{TAPTK}$	4.0	ns, min
TMS and TDI Hold times after TCK	$T_{TCKTAP}$	2.0	ns, min
Output delay from clock TCK to output TDO	$T_{TCKTDO}$	11.0	ns, max
Maximum TCK clock frequency	$F_{TCK}$	33	MHz, max



## Virtex-E Pin-to-Pin Output Parameter Guidelines

Testing of switching parameters is modeled after testing methods specified by MIL-M-38510/605. All devices are 100% functionally tested. Listed below are representative values for typical pin locations and normal clock loading. Values are expressed in nanoseconds unless otherwise noted.

### Global Clock Input to Output Delay for LVTTTL, 12 mA, Fast Slew Rate, *with* DLL

Description <sup>1</sup>	Symbol	Device	Speed Grade <sup>2, 3</sup>				Units
			Min <sup>4</sup>	-8	-7	-6	
LVTTTL Global Clock Input to Output Delay using Output Flip-flop, 12 mA, Fast Slew Rate, <i>with</i> DLL. For data <i>output</i> with different standards, adjust the delays with the values shown in <b>IOB Output Switching Characteristics Standard Adjustments</b> , page 9.	T <sub>ICKOFDLL</sub>	XCV50E	1.0	3.1	3.1	3.1	ns
		XCV100E	1.0	3.1	3.1	3.1	ns
		XCV200E	1.0	3.1	3.1	3.1	ns
		XCV300E	1.0	3.1	3.1	3.1	ns
		XCV400E	1.0	3.1	3.1	3.1	ns
		XCV600E	1.0	3.1	3.1	3.1	ns
		XCV1000E	1.0	3.1	3.1	3.1	ns
		XCV1600E	1.0	3.1	3.1	3.1	ns
		XCV2000E	1.0	3.1	3.1	3.1	ns
		XCV2600E <sup>5</sup>	1.0	3.1	3.1	3.1	ns
XCV3200E <sup>5</sup>	1.0	3.1	3.1	3.1	ns		

#### Notes:

- Listed above are representative values where one global clock input drives one vertical clock line in each accessible column, and where all accessible IOB and CLB flip-flops are clocked by the global clock net.
- Output timing is measured at 50% V<sub>CC</sub> threshold with 35 pF external capacitive load. For other I/O standards and different loads, see [Table 2](#) and [Table 3](#).
- DLL output jitter is already included in the timing calculation.
- The numbers for Min are **Advance** product specification numbers. See [Definition of Terms](#), page 1 for a description.
- The numbers for XCV2600E and XCV3200E devices are **Preview** specification numbers for all speed grades.

## Global Clock Input to Output Delay for LVTTTL, 12 mA, Fast Slew Rate, *without* DLL

Description <sup>1</sup>	Symbol	Device	Speed Grade <sup>2</sup>				Units
			Min <sup>4</sup>	-8	-7	-6	
LVTTTL Global Clock Input to Output Delay using Output Flip-flop, 12 mA, Fast Slew Rate, <i>without</i> DLL. For data <i>output</i> with different standards, adjust the delays with the values shown in <b>IOB Output Switching Characteristics Standard Adjustments</b> , page 9.	T <sub>ICKOF</sub>	XCV50E	1.5	4.2	4.4	4.6	ns
		XCV100E	1.5	4.2	4.4	4.6	ns
		XCV200E	1.5	4.3	4.5	4.7	ns
		XCV300E	1.5	4.3	4.5	4.7	ns
		XCV400E	1.5	4.4	4.6	4.8	ns
		XCV600E	1.6	4.5	4.7	4.9	ns
		XCV1000E	1.7	4.6	4.8	5.0	ns
		XCV1600E	1.8	4.7	4.9	5.1	ns
		XCV2000E	1.8	4.8	5.0	5.2	ns
		XCV2600E <sup>4</sup>	2.0	5.0	5.2	5.4	ns
XCV3200E <sup>4</sup>	2.2	5.2	5.4	5.6	ns		

### Notes:

1. Listed above are representative values where one global clock input drives one vertical clock line in each accessible column, and where all accessible IOB and CLB flip-flops are clocked by the global clock net.
2. Output timing is measured at 50% V<sub>CC</sub> threshold with 35 pF external capacitive load. For other I/O standards and different loads, see [Table 2](#) and [Table 3](#).
3. The numbers for Min are **Advance** product specification numbers. See [Definition of Terms](#), page 1 for a description.
4. The numbers for XCV2600E and XCV3200E devices are **Preview** specification numbers for all speed grades.

## Virtex-E Pin-to-Pin Input Parameter Guidelines

Testing of switching parameters is modeled after testing methods specified by MIL-M-38510/605. All devices are 100% functionally tested. Listed below are representative values for typical pin locations and normal clock loading. Values are expressed in nanoseconds unless otherwise noted

### Global Clock Set-Up and Hold for LVTTTL Standard, *with DLL*

Description <sup>1</sup>	Symbol	Device	Speed Grade <sup>2, 3</sup>				Units
			Min <sup>4</sup>	-8	-7	-6	
Input Setup and Hold Time Relative to Global Clock Input Signal for LVTTTL Standard. For data input with different standards, adjust the setup time delay by the values shown in <b>IOB Input Switching Characteristics Standard Adjustments</b> , page 7.							
No Delay Global Clock and IFF, with DLL	$T_{PSDLL}/T_{PHDLL}$	XCV50E	1.5 / -0.4	1.5 / -0.4	1.6 / -0.4	1.7 / -0.4	ns
		XCV100E	1.5 / -0.4	1.5 / -0.4	1.6 / -0.4	1.7 / -0.4	ns
		XCV200E	1.5 / -0.4	1.5 / -0.4	1.6 / -0.4	1.7 / -0.4	ns
		XCV300E	1.5 / -0.4	1.5 / -0.4	1.6 / -0.4	1.7 / -0.4	ns
		XCV400E	1.5 / -0.4	1.5 / -0.4	1.6 / -0.4	1.7 / -0.4	ns
		XCV600E	1.5 / -0.4	1.5 / -0.4	1.6 / -0.4	1.7 / -0.4	ns
		XCV1000E	1.5 / -0.4	1.5 / -0.4	1.6 / -0.4	1.7 / -0.4	ns
		XCV1600E	1.5 / -0.4	1.5 / -0.4	1.6 / -0.4	1.7 / -0.4	ns
		XCV2000E	1.5 / -0.4	1.5 / -0.4	1.6 / -0.4	1.7 / -0.4	ns
		XCV2600E <sup>5</sup>	1.5 / -0.4	1.5 / -0.4	1.6 / -0.4	1.7 / -0.4	ns
		XCV3200E <sup>5</sup>	1.5 / -0.4	1.5 / -0.4	1.6 / -0.4	1.7 / -0.4	ns

#### Notes:

1. IFF = Input Flip-Flop or Latch
2. Setup time is measured relative to the Global Clock input signal with the fastest route and the lightest load. Hold time is measured relative to the Global Clock input signal with the slowest route and heaviest load.
3. DLL output jitter is already included in the timing calculation.
4. The numbers for Min are **Advance** product specification numbers. See **Definition of Terms**, page 1 for a description.
5. The numbers for XCV2600E and XCV3200E devices are **Preview** specification numbers for all speed grades.

## Global Clock Set-Up and Hold for LVTTTL Standard, *without* DLL

Description <sup>1</sup>	Symbol	Device	Speed Grade <sup>2, 3</sup>				Units
			Min <sup>4</sup>	-8	-7	-6	
Input Setup and Hold Time Relative to Global Clock Input Signal for LVTTTL Standard. For data input with different standards, adjust the setup time delay by the values shown in <b>IOB Input Switching Characteristics Standard Adjustments</b> , page 7.							
Full Delay Global Clock and IFF, without DLL	$T_{PSFD}/T_{PHFD}$	XCV50E	1.8 / 0	1.8 / 0	1.8 / 0	1.8 / 0	ns
		XCV100E	1.8 / 0	1.8 / 0	1.8 / 0	1.8 / 0	ns
		XCV200E	1.9 / 0	1.9 / 0	1.9 / 0	1.9 / 0	ns
		XCV300E	2.0 / 0	2.0 / 0	2.0 / 0	2.0 / 0	ns
		XCV400E	2.0 / 0	2.0 / 0	2.0 / 0	2.0 / 0	ns
		XCV600E	2.1 / 0	2.1 / 0	2.1 / 0	2.1 / 0	ns
		XCV1000E	2.3 / 0	2.3 / 0	2.3 / 0	2.3 / 0	ns
		XCV1600E	2.5 / 0	2.5 / 0	2.5 / 0	2.5 / 0	ns
		XCV2000E	2.5 / 0	2.5 / 0	2.5 / 0	2.5 / 0	ns
		XCV2600E <sup>5</sup>	2.7 / 0	2.7 / 0	2.7 / 0	2.7 / 0	ns
XCV3200E <sup>5</sup>	2.8 / 0	2.8 / 0	2.8 / 0	2.8 / 0	ns		

### Notes:

1. IFF = Input Flip-Flop or Latch
2. Setup time is measured relative to the Global Clock input signal with the fastest route and the lightest load. Hold time is measured relative to the Global Clock input signal with the slowest route and heaviest load.
3. A Zero "0" Hold Time listing indicates no hold time or a negative hold time. Negative values can not be guaranteed "best-case", but if a "0" is listed, there is no positive hold time.
4. The numbers for Min are **Advance** product specification numbers. See **Definition of Terms**, page 1 for a description.
5. The numbers for XCV2600E and XCV3200E devices are **Preview** specification numbers for all speed grades.

## DLL Timing Parameters

Switching parameters testing is modeled after testing methods specified by MIL-M-38510/605; all devices are 100 percent functionally tested. Because of the difficulty in directly measuring many internal timing parameters, those parameters are derived from benchmark timing patterns. The following guidelines reflect worst-case values across the recommended operating conditions.

Description	Symbol	$F_{CLKIN}$	Speed Grade <sup>1</sup>						Units
			-8		-7		-6		
			Min	Max	Min	Max	Min	Max	
Input Clock Frequency (CLKDLLHF)	FCLKINHF		60	350	60	320	60	275	MHz
Input Clock Frequency (CLKDLL)	FCLKINLF		25	160	25	160	25	135	MHz
Input Clock Low/High Pulse Width	$T_{DLLPW}$	$\geq 5$ MHz	5.0		5.0		5.0		ns
		$\geq 50$ MHz	3.0		3.0		3.0		ns
		$\geq 100$ MHz	2.4		2.4		2.4		ns
		$\geq 150$ MHz	2.0		2.0		2.0		ns
		$\geq 200$ MHz	1.8		1.8		1.8		ns
		$\geq 250$ MHz	1.5		1.5		1.5		ns
		$\geq 300$ MHz	1.3		1.3		NA		ns

**Notes:**

1. All specifications correspond to Commercial Operating Temperatures (0°C to +85°C).

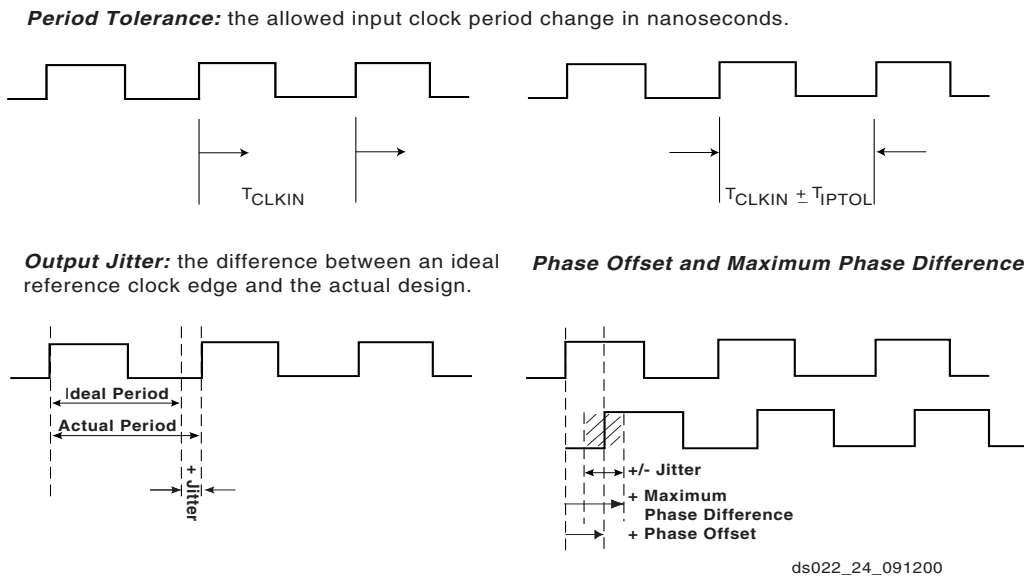

Figure 4: DLL Timing Waveforms

## DLL Clock Tolerance, Jitter, and Phase Information

All DLL output jitter and phase specifications determined through statistical measurement at the package pins using a clock mirror configuration and matched drivers.

Description	Symbol	$F_{CLKIN}$	CLKDLLHF		CLKDLL		Units
			Min	Max	Min	Max	
Input Clock Period Tolerance	$T_{IPTOL}$		-	1.0	-	1.0	ns
Input Clock Jitter Tolerance (Cycle to Cycle)	$T_{IJITCC}$		-	± 150	-	± 300	ps
Time Required for DLL to Acquire Lock	$T_{LOCK}$	> 60 MHz	-	20	-	20	μs
		50 - 60 MHz	-	-	-	25	μs
		40 - 50 MHz	-	-	-	50	μs
		30 - 40 MHz	-	-	-	90	μs
		25 - 30 MHz	-	-	-	120	μs
Output Jitter (cycle-to-cycle) for any DLL Clock Output <sup>1</sup>	$T_{OJITCC}$			± 60		± 60	ps
Phase Offset between CLKIN and CLKO <sup>2</sup>	$T_{PHIO}$			± 100		± 100	ps
Phase Offset between Clock Outputs on the DLL <sup>3</sup>	$T_{PHOO}$			± 140		± 140	ps
Maximum Phase Difference between CLKIN and CLKO <sup>4</sup>	$T_{PHIOM}$			± 160		± 160	ps
Maximum Phase Difference between Clock Outputs on the DLL <sup>5</sup>	$T_{PHOOM}$			± 200		± 200	ps

### Notes:

- Output Jitter** is cycle-to-cycle jitter measured on the DLL output clock, *excluding* input clock jitter.
- Phase Offset between CLKIN and CLKO** is the worst-case fixed time difference between rising edges of CLKIN and CLKO, *excluding* Output Jitter and input clock jitter.
- Phase Offset between Clock Outputs on the DLL** is the worst-case fixed time difference between rising edges of any two DLL outputs, *excluding* Output Jitter and input clock jitter.
- Maximum Phase Difference between CLKIN and CLKO** is the sum of Output Jitter and Phase Offset between CLKIN and CLKO, or the greatest difference between CLKIN and CLKO rising edges due to DLL alone (*excluding* input clock jitter).
- Maximum Phase Difference between Clock Outputs on the DLL** is the sum of Output Jitter and Phase Offset between any DLL clock outputs, or the greatest difference between any two DLL output rising edges due to DLL alone (*excluding* input clock jitter).
- All specifications correspond to Commercial Operating Temperatures (0°C to +85°C).

## Revision History

The following table shows the revision history for this document.

Date	Version	Revision
12/7/99	1.0	Initial Xilinx release.
1/10/00	1.1	Re-released with spd.txt v. 1.18, FG860/900/1156 package information, and additional DLL, Select RAM and SelectI/O information.
1/28/00	1.2	Added Delay Measurement Methodology table, updated SelectI/O section, Figures 30, 54, & 55, text explaining Table 5, $T_{BYP}$ values, buffered Hex Line info, p. 8, I/O Timing Measurement notes, notes for Tables 15, 16, and corrected F1156 pinout table footnote references.
2/29/00	1.3	Updated pinout tables, $V_{CC}$ page 20, and corrected Figure 20.
5/23/00	1.4	Correction to table on p. 22.

Date	Version	Revision
7/10/00	1.5	<ul style="list-style-type: none"> <li>Numerous minor edits.</li> <li>Data sheet upgraded to Preliminary.</li> <li>Preview -8 numbers added to <b>Virtex-E Electrical Characteristics</b> tables.</li> </ul>
8/1/00	1.6	<ul style="list-style-type: none"> <li>Reformatted entire document to follow new style guidelines.</li> <li>Changed speed grade values in tables on pages 35-37.</li> </ul>
9/20/00	1.7	<ul style="list-style-type: none"> <li>Min values added to <b>Virtex-E Electrical Characteristics</b> tables.</li> <li>XCV2600E and XCV3200E numbers added to <b>Virtex-E Electrical Characteristics</b> tables (Module 3).</li> <li>Corrected user I/O count for XCV100E device in Table 1 (Module 1).</li> <li>Changed several pins to “No Connect in the XCV100E” and removed duplicate <math>V_{CCINT}</math> pins in Table ~ (Module 4).</li> <li>Changed pin J10 to “No connect in XCV600E” in Table 74 (Module 4).</li> <li>Changed pin J30 to “VREF option only in the XCV600E” in Table 74 (Module 4).</li> <li>Corrected pair 18 in Table 75 (Module 4) to be “AO in the XCV1000E, XCV1600E”.</li> </ul>
11/20/00	1.8	<ul style="list-style-type: none"> <li>Upgraded speed grade -8 numbers in <b>Virtex-E Electrical Characteristics</b> tables to Preliminary.</li> <li>Updated minimums in Table 13 and added notes to Table 14.</li> <li>Added to note 2 to <b>Absolute Maximum Ratings</b>.</li> <li>Changed speed grade -8 numbers for <math>T_{SHCKO32}</math>, <math>T_{REG}</math>, <math>T_{BCCS}</math>, and <math>T_{ICKOF}</math></li> <li>Changed all minimum hold times to <math>-0.4</math> under <b>Global Clock Set-Up and Hold for LVTTTL Standard, with DLL</b>.</li> <li>Revised maximum <math>T_{DLLPW}</math> in -6 speed grade for <b>DLL Timing Parameters</b>.</li> <li>Changed GCLK0 to BA22 for FG860 package in Table 46.</li> </ul>
2/12/01	1.9	<ul style="list-style-type: none"> <li>Revised footnote for Table 14.</li> <li>Added numbers to <b>Virtex-E Electrical Characteristics</b> tables for XCV1000E and XCV2000E devices.</li> <li>Updated Table 27 and Table 78 to include values for XCV400E and XCV600E devices.</li> <li>Revised Table 62 to include pinout information for the XCV400E and XCV600E devices in the BG560 package.</li> <li>Updated footnotes 1 and 2 for Table 76 to include XCV2600E and XCV3200E devices.</li> </ul>
4/02/01	2.0	<ul style="list-style-type: none"> <li>Updated numerous values in <b>Virtex-E Switching Characteristics</b> tables.</li> <li>Converted data sheet to modularized format. See the <b>Virtex-E Data Sheet</b> section.</li> </ul>
4/19/01	2.1	<ul style="list-style-type: none"> <li>Updated values in <b>Virtex-E Switching Characteristics</b> tables.</li> </ul>
07/23/01	2.2	<ul style="list-style-type: none"> <li>Under <b>Absolute Maximum Ratings</b>, changed (<math>T_{SOL}</math>) to 220 °C.</li> <li>Changes made to SSTL symbol names in <b>IOB Input Switching Characteristics Standard Adjustments</b> table.</li> </ul>
07/26/01	2.3	<ul style="list-style-type: none"> <li>Removed <math>T_{SOL}</math> parameter and added footnote to <b>Absolute Maximum Ratings</b> table.</li> </ul>
09/18/01	2.4	<ul style="list-style-type: none"> <li>Reworded power supplies footnote to <b>Absolute Maximum Ratings</b> table.</li> </ul>

## Virtex-E Data Sheet

The Virtex-E Data Sheet contains the following modules:

- DS022-1, Virtex-E 1.8V FPGAs:  
[Introduction and Ordering Information \(Module 1\)](#)
- DS022-2, Virtex-E 1.8V FPGAs:  
[Functional Description \(Module 2\)](#)
- DS022-3, Virtex-E 1.8V FPGAs:  
**DC and Switching Characteristics (Module 3)**
- DS022-4, Virtex-E 1.8V FPGAs:  
[Pinout Tables \(Module 4\)](#)