

## Architectural Description

### Virtex-E Array

The Virtex-E user-programmable gate array (see **Figure 1**) comprises two major configurable elements: configurable logic blocks (CLBs) and input/output blocks (IOBs).

- CLBs provide the functional elements for constructing logic.
- IOBs provide the interface between the package pins and the CLBs.

CLBs interconnect through a general routing matrix (GRM). The GRM comprises an array of routing switches located at the intersections of horizontal and vertical routing channels. Each CLB nests into a VersaBlock™ that also provides local routing resources to connect the CLB to the GRM.

The VersaRing™ I/O interface provides additional routing resources around the periphery of the device. This routing improves I/O routability and facilitates pin locking.

The Virtex-E architecture also includes the following circuits that connect to the GRM:

- Dedicated block memories of 4096 bits each
- Clock DLLs for clock-distribution delay compensation and clock domain control
- 3-State buffers (BUFTs) associated with each CLB that drive dedicated segmentable horizontal routing resources

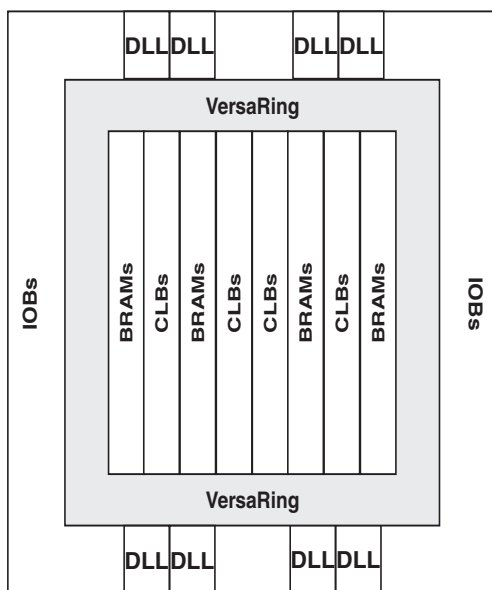

Figure 1: Virtex-E Architecture Overview

Values stored in static memory cells control the configurable logic elements and interconnect resources. These values load into the memory cells on power-up, and can reload if necessary to change the function of the device.

### Input/Output Block

The Virtex-E IOB, **Figure 2**, features SelectIO+™ inputs and outputs that support a wide variety of I/O signalling standards (see **Table 1**).

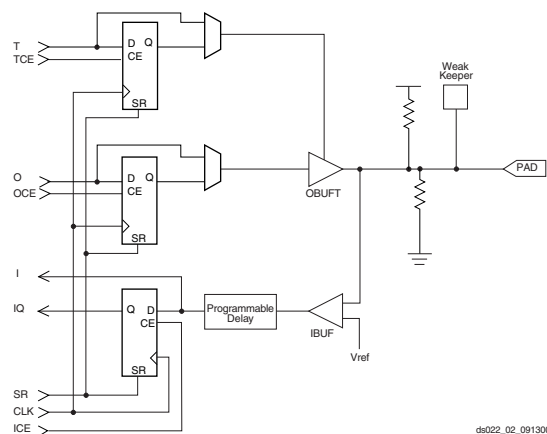

Figure 2: Virtex-E Input/Output Block (IOB)

The three IOB storage elements function either as edge-triggered D-type flip-flops or as level-sensitive latches. Each IOB has a clock signal (CLK) shared by the three flip-flops and independent clock enable signals for each flip-flop.

Table 1: Supported I/O Standards

I/O Standard	Output $V_{CCO}$	Input $V_{CCO}$	Input $V_{REF}$	Board Termination Voltage ( $V_{TT}$ )
LVTTL	3.3	3.3	N/A	N/A
LVCOS2	2.5	2.5	N/A	N/A
LVCOS18	1.8	1.8	N/A	N/A
SSTL3 I & II	3.3	N/A	1.50	1.50
SSTL2 I & II	2.5	N/A	1.25	1.25
GTL	N/A	N/A	0.80	1.20
GTL+	N/A	N/A	1.0	1.50
HSTL I	1.5	N/A	0.75	0.75
HSTL III & IV	1.5	N/A	0.90	1.50
CTT	3.3	N/A	1.50	1.50
AGP-2X	3.3	N/A	1.32	N/A
PCI33_3	3.3	3.3	N/A	N/A
PCI66_3	3.3	3.3	N/A	N/A
BLVDS & LVDS	2.5	N/A	N/A	N/A
LVPECL	3.3	N/A	N/A	N/A

In addition to the CLK and CE control signals, the three flip-flops share a Set/Reset (SR). For each flip-flop, this signal can be independently configured as a synchronous Set, a synchronous Reset, an asynchronous Preset, or an asynchronous Clear.

The output buffer and all of the IOB control signals have independent polarity controls.

All pads are protected against damage from electrostatic discharge (ESD) and from over-voltage transients. When PCI 3.3 V compliance is required, a conventional clamp diode is connected to the output supply voltage,  $V_{CCO}$ .

Optional pull-up, pull-down and weak-keeper circuits are attached to each pad. Prior to configuration all outputs not involved in configuration are forced into their high-impedance state. The pull-down resistors and the weak-keeper circuits are inactive, but IOs can optionally be pulled up.

The activation of pull-up resistors prior to configuration is controlled on a global basis by the configuration mode pins. If the pull-up resistors are not activated, all the pins are in a high-impedance state. Consequently, external pull-up or pull-down resistors must be provided on pins required to be at a well-defined logic level prior to configuration.

All Virtex-E IOBs support IEEE 1149.1-compatible boundary scan testing.

### Input Path

The Virtex-E IOB input path routes the input signal directly to internal logic and/ or through an optional input flip-flop.

An optional delay element at the D-input of this flip-flop eliminates pad-to-pad hold time. The delay is matched to the internal clock-distribution delay of the FPGA, and when used, assures that the pad-to-pad hold time is zero.

Each input buffer can be configured to conform to any of the low-voltage signalling standards supported. In some of these standards the input buffer utilizes a user-supplied threshold voltage,  $V_{REF}$ . The need to supply  $V_{REF}$  imposes constraints on which standards can be used in close proximity to each other. See "I/O Banking" on page 2.

There are optional pull-up and pull-down resistors at each input for use after configuration. Their value is in the range 50 - 100 k $\Omega$ .

### Output Path

The output path includes a 3-state output buffer that drives the output signal onto the pad. The output signal can be routed to the buffer directly from the internal logic or through an optional IOB output flip-flop.

The 3-state control of the output can also be routed directly from the internal logic or through a flip-flop that provides synchronous enable and disable.

Each output driver can be individually programmed for a wide range of low-voltage signalling standards. Each output buffer can source up to 24 mA and sink up to 48 mA. Drive strength and slew rate controls minimize bus transients.

In most signalling standards, the output High voltage depends on an externally supplied  $V_{CCO}$  voltage. The need to supply  $V_{CCO}$  imposes constraints on which standards can be used in close proximity to each other. See "I/O Banking" on page 2.

An optional weak-keeper circuit is connected to each output. When selected, the circuit monitors the voltage on the pad and weakly drives the pin High or Low to match the input signal. If the pin is connected to a multiple-source signal, the weak keeper holds the signal in its last state if all drivers are disabled. Maintaining a valid logic level in this way eliminates bus chatter.

Since the weak-keeper circuit uses the IOB input buffer to monitor the input level, an appropriate  $V_{REF}$  voltage must be provided if the signalling standard requires one. The provision of this voltage must comply with the I/O banking rules.

### I/O Banking

Some of the I/O standards described above require  $V_{CCO}$  and/or  $V_{REF}$  voltages. These voltages are externally supplied and connected to device pins that serve groups of IOBs, called banks. Consequently, restrictions exist about which I/O standards can be combined within a given bank.

Eight I/O banks result from separating each edge of the FPGA into two banks, as shown in **Figure 3**. Each bank has multiple  $V_{CCO}$  pins, all of which must be connected to the same voltage. This voltage is determined by the output standards in use.

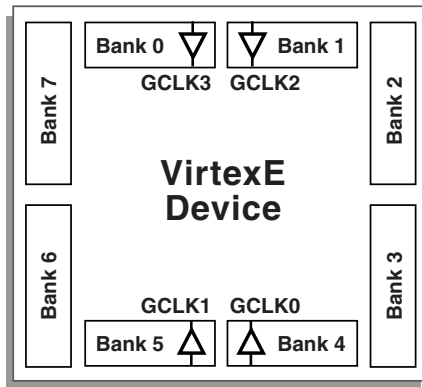

ds022\_03\_121799

**Figure 3: Virtex-E I/O Banks**

Within a bank, output standards can be mixed only if they use the same  $V_{CCO}$ . Compatible standards are shown in **Table 2**. GTL and GTL+ appear under all voltages because their open-drain outputs do not depend on  $V_{CCO}$ .

**Table 2: Compatible Output Standards**

$V_{CCO}$	Compatible Standards
3.3 V	PCI, LVTTTL, SSTL3 I, SSTL3 II, CTT, AGP, GTL, GTL+, LVPECL
2.5 V	SSTL2 I, SSTL2 II, LVCMOS2, GTL, GTL+, BLVDS, LVDS
1.8 V	LVCMOS18, GTL, GTL+
1.5 V	HSTL I, HSTL III, HSTL IV, GTL, GTL+

Some input standards require a user-supplied threshold voltage,  $V_{REF}$ . In this case, certain user-I/O pins are automatically configured as inputs for the  $V_{REF}$  voltage. Approximately one in six of the I/O pins in the bank assume this role.

The  $V_{REF}$  pins within a bank are interconnected internally and consequently only one  $V_{REF}$  voltage can be used within each bank. All  $V_{REF}$  pins in the bank, however, must be connected to the external voltage source for correct operation.

Within a bank, inputs that require  $V_{REF}$  can be mixed with those that do not. However, only one  $V_{REF}$  voltage can be used within a bank.

In Virtex-E, input buffers with LVTTTL, LVCMOS2, LVCMOS18, PCI33\_3, PCI66\_3 standards are supplied by  $V_{CCO}$  rather than  $V_{CCINT}$ . For these standards, only input and output buffers that have the same  $V_{CCO}$  can be mixed together.

The  $V_{CCO}$  and  $V_{REF}$  pins for each bank appear in the device pin-out tables and diagrams. The diagrams also show the bank affiliation of each I/O.

Within a given package, the number of  $V_{REF}$  and  $V_{CCO}$  pins can vary depending on the size of device. In larger devices, more I/O pins convert to  $V_{REF}$  pins. Since these are always a super set of the  $V_{REF}$  pins used for smaller devices, it is possible to design a PCB that permits migration to a larger device if necessary. All the  $V_{REF}$  pins for the largest device anticipated must be connected to the  $V_{REF}$  voltage, and not used for I/O.

In smaller devices, some  $V_{CCO}$  pins used in larger devices do not connect within the package. These unconnected pins can be left unconnected externally, or they can be connected to the  $V_{CCO}$  voltage to permit migration to a larger device, if necessary.

### Configurable Logic Block

The basic building block of the Virtex-E CLB is the logic cell (LC). An LC includes a 4-input function generator, carry logic, and a storage element. The output from the function generator in each LC drives both the CLB output and the D input of the flip-flop. Each Virtex-E CLB contains four LCs, organized in two similar slices, as shown in **Figure 4**. **Figure 5** shows a more detailed view of a single slice.

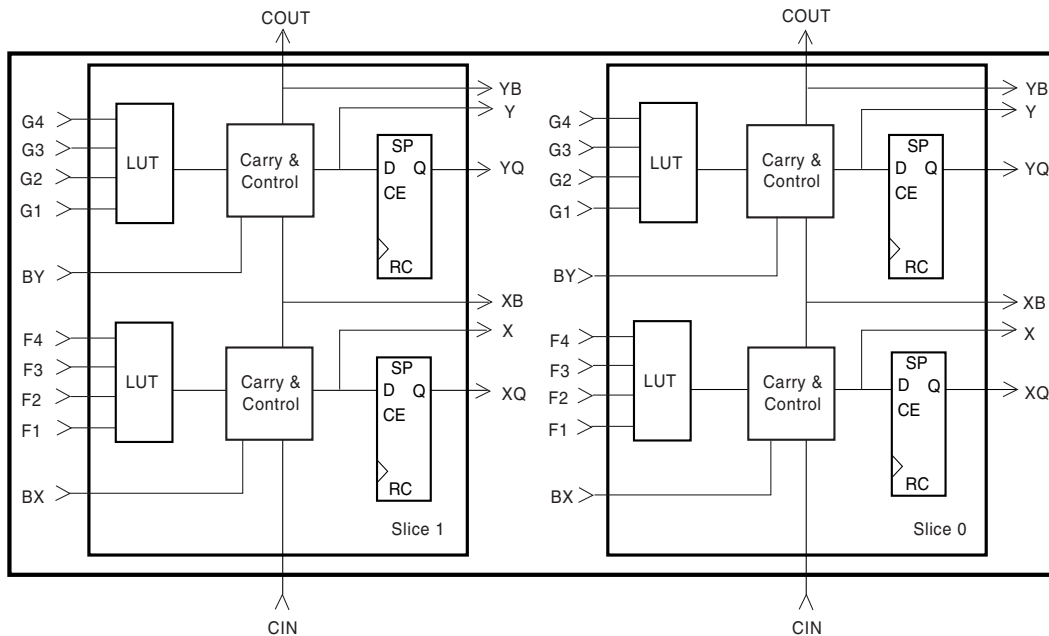

ds022\_04\_121799

Figure 4: 2-Slice Virtex-E CLB

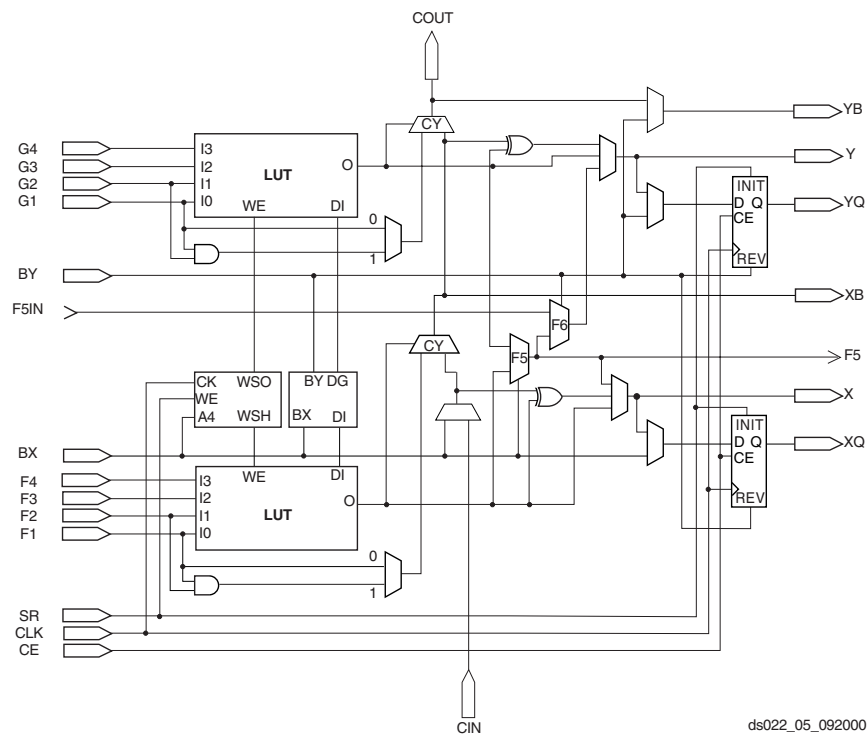

ds022\_05\_092000

Figure 5: Detailed View of Virtex-E Slice

In addition to the four basic LCs, the Virtex-E CLB contains logic that combines function generators to provide functions of five or six inputs. Consequently, when estimating the number of system gates provided by a given device, each CLB counts as 4.5 LCs.

### Look-Up Tables

Virtex-E function generators are implemented as 4-input look-up tables (LUTs). In addition to operating as a function generator, each LUT can provide a 16 x 1-bit synchronous RAM. Furthermore, the two LUTs within a slice can be com-

bined to create a 16 x 2-bit or 32 x 1-bit synchronous RAM, or a 16 x 1-bit dual-port synchronous RAM.

The Virtex-E LUT can also provide a 16-bit shift register that is ideal for capturing high-speed or burst-mode data. This mode can also be used to store data in applications such as Digital Signal Processing.

**Storage Elements**

The storage elements in the Virtex-E slice can be configured either as edge-triggered D-type flip-flops or as level-sensitive latches. The D inputs can be driven either by the function generators within the slice or directly from slice inputs, bypassing the function generators.

In addition to Clock and Clock Enable signals, each Slice has synchronous set and reset signals (SR and BY). SR forces a storage element into the initialization state specified for it in the configuration. BY forces it into the opposite state. Alternatively, these signals can be configured to operate asynchronously. All of the control signals are independently invertible, and are shared by the two flip-flops within the slice.

**Additional Logic**

The F5 multiplexer in each slice combines the function generator outputs. This combination provides either a function generator that can implement any 5-input function, a 4:1 multiplexer, or selected functions of up to nine inputs.

Similarly, the F6 multiplexer combines the outputs of all four function generators in the CLB by selecting one of the F5-multiplexer outputs. This permits the implementation of any 6-input function, an 8:1 multiplexer, or selected functions of up to 19 inputs.

Each CLB has four direct feedthrough paths, two per slice. These paths provide extra data input lines or additional local routing that does not consume logic resources.

Table 3: CLB/Block RAM Column Locations

Virtex-E Device	0	4	8	12	16	20	24	28	32	36	40	44	48	52	56	60	64	68	72	76	80	84	
XCV405E	√	√	√	√	√	√	√			√	√	√	√	√	√	√							
XCV812E	√	√	√	√	√	√	√	√	√	√			√	√	√	√	√	√	√	√	√	√	√

Table 4 shows the amount of block SelectRAM memory that is available in each Virtex-E device.

Table 4: Virtex-E Block SelectRAM Amounts

Virtex-E Device	# of Blocks	Block SelectRAM Bits
XCV405E	140	573,440
XCV812E	280	1,146,880

**Arithmetic Logic**

Dedicated carry logic provides fast arithmetic carry capability for high-speed arithmetic functions. The Virtex-E CLB supports two separate carry chains, one per Slice. The height of the carry chains is two bits per CLB.

The arithmetic logic includes an XOR gate that allows a 2-bit full adder to be implemented within a slice. In addition, a dedicated AND gate improves the efficiency of multiplier implementation.

The dedicated carry path can also be used to cascade function generators for implementing wide logic functions.

**BUFTs**

Each Virtex-E CLB contains two 3-state drivers (BUFTs) that can drive on-chip busses. See "Dedicated Routing" on page 7. Each Virtex-E BUFT has an independent 3-state control pin and an independent input pin.

**Block SelectRAM**

Virtex-E FPGAs incorporate large block SelectRAM memories. These complement the Distributed SelectRAM memories that provide shallow RAM structures implemented in CLBs.

Block SelectRAM memory blocks are organized in columns, starting at the left (column 0) and right outside edges and inserted every four CLB columns (see notes for smaller devices). Each memory block is four CLBs high, and each memory column extends the full height of the chip, immediately adjacent (to the right, except for column 0) of the CLB column locations indicated in Table 3.

Each block SelectRAM cell, as illustrated in Figure 6, is a fully synchronous dual-ported (True Dual Port™) 4096-bit RAM with independent control signals for each port. The data widths of the two ports can be configured independently, providing built-in bus-width conversion.

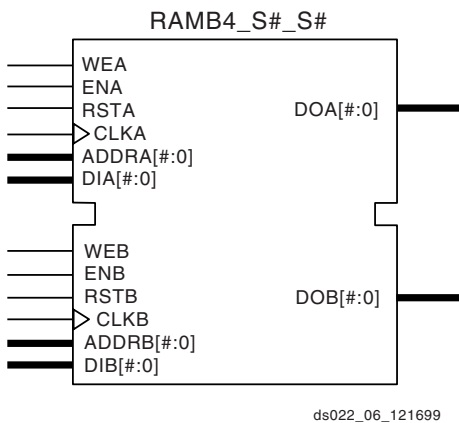

Figure 6: Dual-Port Block SelectRAM

Table 5 shows the depth and width aspect ratios for the block SelectRAM. The Virtex-E block SelectRAM also includes dedicated routing to provide an efficient interface with both CLBs and other block SelectRAM modules.

Table 5: Block SelectRAM Port Aspect Ratios

Width	Depth	ADDR Bus	Data Bus
1	4096	ADDR<11:0>	DATA<0>
2	2048	ADDR<10:0>	DATA<1:0>
4	1024	ADDR<9:0>	DATA<3:0>
8	512	ADDR<8:0>	DATA<7:0>
16	256	ADDR<7:0>	DATA<15:0>

## Programmable Routing Matrix

It is the longest delay path that limits the speed of any worst-case design. Consequently, the Virtex-E routing architecture and its place-and-route software were defined in a joint optimization process. This joint optimization minimizes long-path delays, and consequently, yields the best system performance.

The joint optimization also reduces design compilation times because the architecture is software-friendly. Design cycles are correspondingly reduced due to shorter design iteration times.

## Local Routing

The VersaBlock, shown in Figure 7, provides local routing resources with the following types of connections:

- Interconnections among the LUTs, flip-flops, and GRM
- Internal CLB feedback paths that provide high-speed connections to LUTs within the same CLB, chaining them together with minimal routing delay
- Direct paths that provide high-speed connections between horizontally adjacent CLBs, eliminating the delay of the GRM

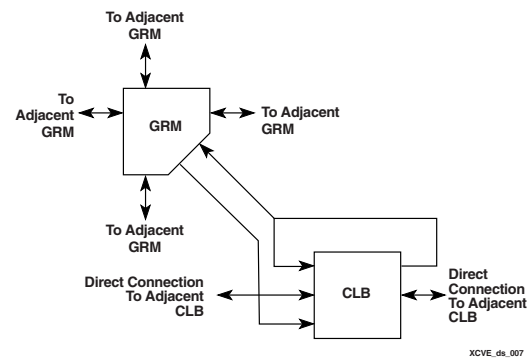

Figure 7: Virtex-E Local Routing

## General Purpose Routing

Most Virtex-E signals are routed on the general purpose routing, and consequently, the majority of interconnect resources are associated with this level of the routing hierarchy. The general routing resources are located in horizontal and vertical routing channels associated with the CLB rows and columns. The general-purpose routing resources are listed below.

- Adjacent to each CLB is a General Routing Matrix (GRM). The GRM is the switch matrix through which horizontal and vertical routing resources connect, and is also the means by which the CLB gains access to the general purpose routing.
- 24 single-length lines route GRM signals to adjacent GRMs in each of the four directions.
- 72 buffered Hex lines route GRM signals to another GRMs six-blocks away in each one of the four directions. Organized in a staggered pattern, Hex lines are driven only at their endpoints. Hex-line signals can be accessed either at the endpoints or at the midpoint (three blocks from the source). One third of the Hex lines are bidirectional, while the remaining ones are uni-directional.
- 12 Longlines are buffered, bidirectional wires that distribute signals across the device quickly and efficiently. Vertical Longlines span the full height of the device, and horizontal ones span the full width of the device.

## I/O Routing

Virtex-E devices have additional routing resources around their periphery that form an interface between the CLB array and the IOBs. This additional routing, called the VersaRing, facilitates pin-swapping and pin-locking, such that logic redesigns can adapt to existing PCB layouts. Time-to-market is reduced, since PCBs and other system components can be manufactured while the logic design is still in progress.



**Dedicated Routing**

Some signal classes require dedicated routing resources to maximize performance. In the Virtex-E architecture, dedicated routing resources are provided for two signal classes.

- Horizontal routing resources are provided for on-chip 3-state busses. Four partitionable bus lines are provided per CLB row, permitting multiple busses within a row, as shown in **Figure 8**.

- Two dedicated nets per CLB propagate carry signals vertically to the adjacent CLB. Global Clock Distribution Network.
- DLL Location

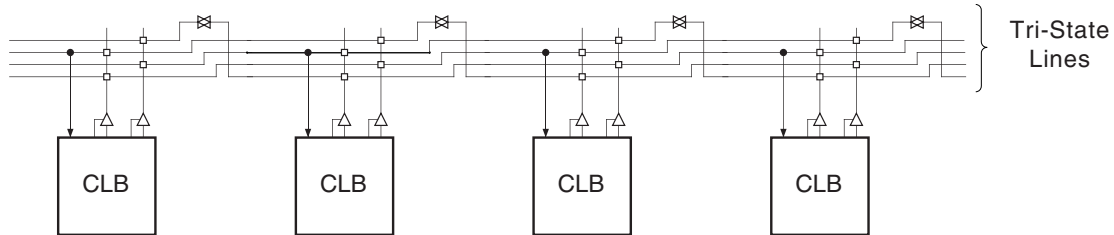

buft\_c.eps

**Figure 8: BUFT Connections to Dedicated Horizontal Bus Lines**

**Clock Routing**

Clock Routing resources distribute clocks and other signals with very high fanout throughout the device. Virtex-E devices include two tiers of clock routing resources referred to as global and local clock routing resources.

- The global routing resources are four dedicated global nets with dedicated input pins that are designed to distribute high-fanout clock signals with minimal skew. Each global clock net can drive all CLB, IOB, and block RAM clock pins. The global nets can be driven only by global buffers. There are four global buffers, one for each global net.

- The local clock routing resources consist of 24 backbone lines, 12 across the top of the chip and 12 across bottom. From these lines, up to 12 unique signals per column can be distributed via the 12 longlines in the column. These local resources are more flexible than the global resources since they are not restricted to routing only to clock pins.

**Global Clock Distribution**

Virtex-E provides high-speed, low-skew clock distribution through the global routing resources described above. A typical clock distribution net is shown in **Figure 9**.

Four global buffers are provided, two at the top center of the device and two at the bottom center. These drive the four global nets that in turn drive any clock pin.

Four dedicated clock pads are provided, one adjacent to each of the global buffers. The input to the global buffer is selected either from these pads or from signals in the general purpose routing.

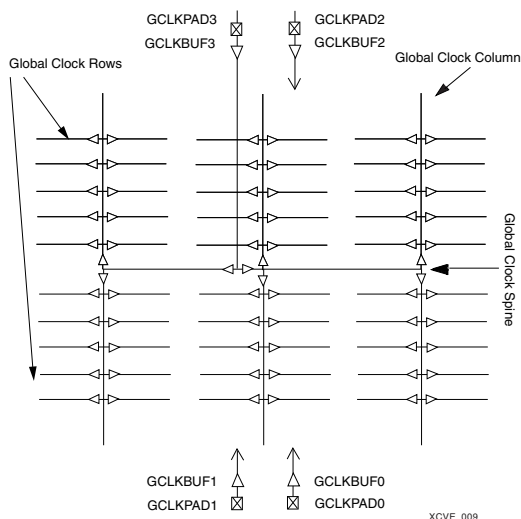

xcve\_009

**Figure 9: Global Clock Distribution Network**

**Digital Delay-Locked Loops**

There are eight DLLs (Delay-Locked Loops) per device, with four located at the top and four at the bottom, **Figure 10**. The DLLs can be used to eliminate skew between the clock input pad and the internal clock input pins throughout the device. Each DLL can drive two global clock networks. The DLL monitors the input clock and the distributed clock, and automatically adjusts a clock delay element. Additional delay is introduced such that clock edges arrive at internal flip-flops synchronized with clock edges arriving at the input.

In addition to eliminating clock-distribution delay, the DLL provides advanced control of multiple clock domains. The

DLL provides four quadrature phases of the source clock, and can double the clock or divide the clock by 1.5, 2, 2.5, 3, 4, 5, 8, or 16.

The DLL also operates as a clock mirror. By driving the output from a DLL off-chip and then back on again, the DLL can be used to de-skew a board level clock among multiple devices.

In order to guarantee that the system clock is operating correctly prior to the FPGA starting up after configuration, the DLL can delay the completion of the configuration process until after it has achieved lock.

For more information about DLL functionality, see the Design Consideration section of the data sheet.

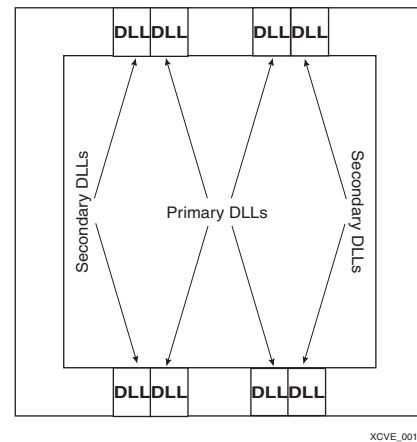

Figure 10: DLL Locations

## Boundary Scan

Virtex-E devices support all the mandatory boundary-scan instructions specified in the IEEE standard 1149.1. A Test Access Port (TAP) and registers are provided that implement the EXTEST, INTEST, SAMPLE/PRELOAD, BYPASS, IDCODE, USERCODE, and HIGHZ instructions. The TAP also supports two internal scan chains and configuration/readback of the device.

The JTAG input pins (TDI, TMS, TCK) do not have a  $V_{CCO}$  requirement, and operate with either 2.5 V or 3.3 V input signalling levels. The output pin (TDO) is sourced from the  $V_{CCO}$  in bank 2, and for proper operation of LVTTTL 3.3 V levels, the bank should be supplied with 3.3 V.

Boundary-scan operation is independent of individual IOB configurations, and unaffected by package type. All IOBs, including un-bonded ones, are treated as independent 3-state bidirectional pins in a single scan chain. Retention of

the bidirectional test capability after configuration facilitates the testing of external interconnections.

Table 6 lists the boundary-scan instructions supported in Virtex-E FPGAs. Internal signals can be captured during EXTEST by connecting them to un-bonded or unused IOBs. They can also be connected to the unused outputs of IOBs defined as unidirectional input pins.

Before the device is configured, all instructions except USER1 and USER2 are available. After configuration, all instructions are available. During configuration, it is recommended that those operations using the boundary-scan register (SAMPLE/PRELOAD, INTEST, EXTEST) not be performed.

In addition to the test instructions outlined above, the boundary-scan circuitry can be used to configure the FPGA, and also to read back the configuration data.



Figure 11 is a diagram of the Virtex-E Series boundary scan logic. It includes three bits of Data Register per IOB, the IEEE 1149.1 Test Access Port controller, and the Instruction Register with decodes.

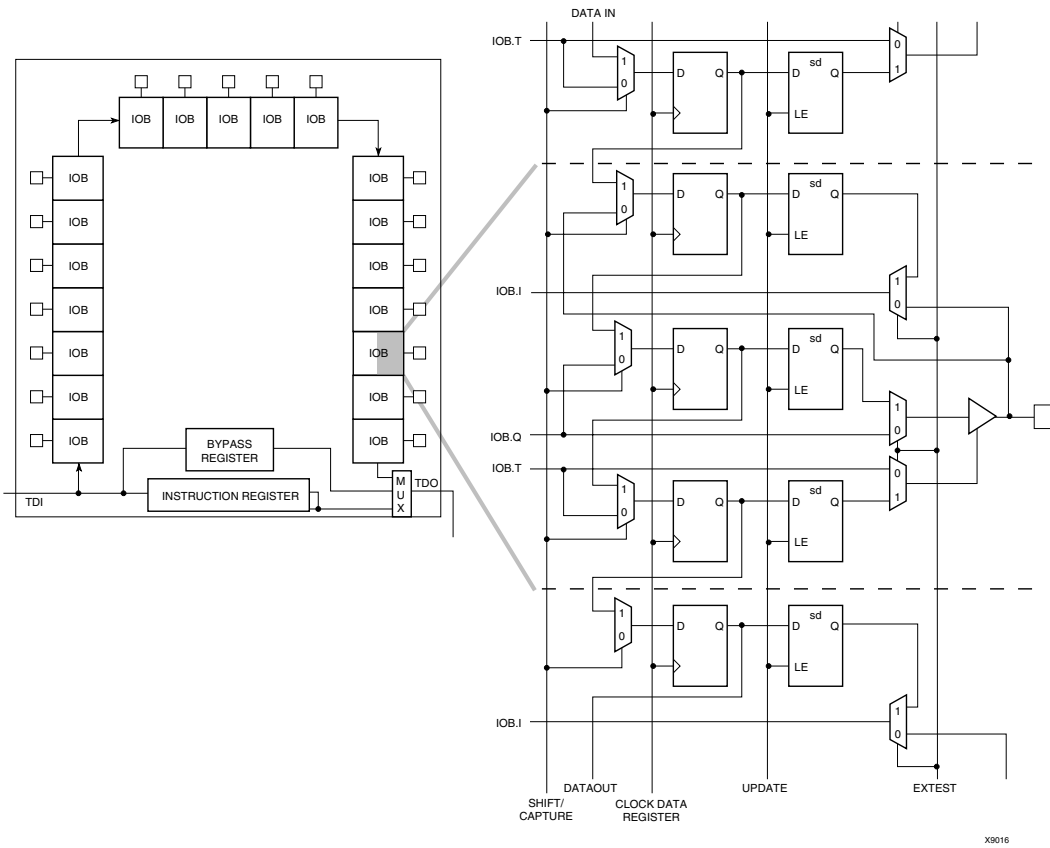

Figure 11: Virtex-E Family Boundary Scan Logic

Table 6: Boundary Scan Instructions

Boundary-Scan Command	Binary Code (4:0)	Description
EXTEST	00000	Enable boundary-scan EXTEST operation.
SAMPLE/PRELOAD	00001	Enable boundary-scan SAMPLE/PRELOAD operation.
USER1	00010	Access user-defined register 1.
USER2	00011	Access user-defined register 2.
CFG_OUT	00100	Access the configuration bus for read operations.
CFG_IN	00101	Access the configuration bus for write operations.
INTEST	00111	Enable boundary-scan INTEST operation.
USERCODE	01000	Enable shifting out USER code.
IDCODE	01001	Enable shifting out of ID Code.
HIGHZ	01010	3-state output pins while enabling the Bypass Register.
JSTART	01100	Clock the start-up sequence when StartupClk is TCK.
BYPASS	11111	Enable BYPASS.
RESERVED	All other codes	Xilinx reserved instructions.

### Instruction Set

The Virtex-E Series boundary scan instruction set also includes instructions to configure the device and read back configuration data (CFG\_IN, CFG\_OUT, and JSTART). The complete instruction set is coded as shown in [Table 6](#).

### Data Registers

The primary data register is the boundary scan register. For each IOB pin in the FPGA, bonded or not, it includes three bits for In, Out, and 3-State Control. Non-IOB pins have appropriate partial bit population if input-only or output-only.

Each EXTEST CAPTURED-OR state captures all In, Out, and 3-state pins.

The other standard data register is the single flip-flop BYPASS register. It synchronizes data being passed through the FPGA to the next downstream boundary scan device.

The FPGA supports up to two additional internal scan chains that can be specified using the BSCAN macro. The macro provides two user pins (SEL1 and SEL2) which are decoded of the USER1 and USER2 instructions respectively. For these instructions, two corresponding pins (TDO1 and TDO2) allow user scan data to be shifted out of TDO.

Likewise, there are individual clock pins (DRCK1 and DRCK2) for each user register. There is a common input pin (TDI) and shared output pins that represent the state of the TAP controller (RESET, SHIFT, and UPDATE).

### Bit Sequence

The order within each IOB is: In, Out, 3-State. The input-only pins contribute only the In bit to the boundary scan I/O data register, while the output-only pins contributes all three bits.

From a cavity-up view of the chip (as shown in EPIC), starting in the upper right chip corner, the boundary scan data-register bits are ordered as shown in [Figure 12](#).

BSDL (Boundary Scan Description Language) files for Virtex-E Series devices are available on the Xilinx web site in the File Download area.

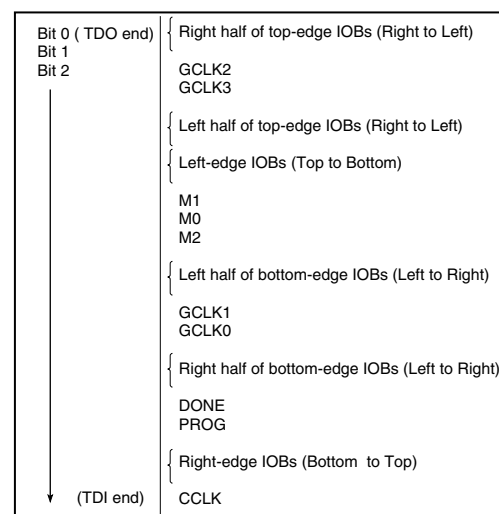

Figure 12: Boundary Scan Bit Sequence

### Identification Registers

The IDCODE register is supported. By using the IDCODE, the device connected to the JTAG port can be determined.

The IDCODE register has the following binary format:

```
vvvv:ffff:ffa:aaaa:aaaa:cccc:cccc:ccc1
```

where

v = the die version number

f = the family code (05 for Virtex-E family)

a = the number of CLB rows (ranges from 16 for XCV50E to 104 for XCV3200E)

c = the company code (49h for Xilinx)

The USERCODE register is supported. By using the USERCODE, a user-programmable identification code can be loaded and shifted out for examination. The identification code (see [Table 7](#)) is embedded in the bitstream during bitstream generation and is valid only after configuration.

### Development System

Virtex-E FPGAs are supported by the Xilinx Foundation and Alliance Series CAE tools. The basic methodology for Virtex-E design consists of three interrelated steps: design entry, implementation, and verification. Industry-standard tools are used for design entry and simulation (for example, Synopsys FPGA Express), while Xilinx provides proprietary architecture-specific tools for implementation.

The Xilinx development system is integrated under the Xilinx Design Manager (XDM™) software, providing designers with a common user interface regardless of their choice of entry and verification tools. The XDM software simplifies the selection of implementation options with pull-down menus and on-line help.

Application programs ranging from schematic capture to Placement and Routing (PAR) can be accessed through the XDM software. The program command sequence is generated prior to execution, and stored for documentation.

Several advanced software features facilitate Virtex-E design. RPMs, for example, are schematic-based macros with relative location constraints to guide their placement. They help ensure optimal implementation of common functions.

For HDL design entry, the Xilinx FPGA Foundation development system provides interfaces to the following synthesis design environments.

- Synopsys (FPGA Compiler, FPGA Express)
- Exemplar (Spectrum)
- Synplicity (Synplify)

For schematic design entry, the Xilinx FPGA Foundation and Alliance development system provides interfaces to the following schematic-capture design environments.

- Mentor Graphics V8 (Design Architect, QuickSim II)
- Viewlogic Systems (Viewdraw)

Third-party vendors support many other environments.

**Table 7: IDCODEs Assigned to Virtex-E FPGAs**

FPGA	IDCODE
XCV405EM	v0C28093h
XCV812EM	v0C38093h

**Note:**

Attempting to load an incorrect bitstream causes configuration to fail and can damage the device.

### Including Boundary Scan in a Design

Since the boundary scan pins are dedicated, no special element needs to be added to the design unless an internal data register (USER1 or USER2) is desired.

If an internal data register is used, insert the boundary scan symbol and connect the necessary pins as appropriate.

A standard interface-file specification, Electronic Design Interchange Format (EDIF), simplifies file transfers into and out of the development system.

Virtex-E FPGAs are supported by a unified library of standard functions. This library contains over 400 primitives and macros, ranging from 2-input AND gates to 16-bit accumulators, and includes arithmetic functions, comparators, counters, data registers, decoders, encoders, I/O functions, latches, Boolean functions, multiplexers, shift registers, and barrel shifters.

The “soft macro” portion of the library contains detailed descriptions of common logic functions, but does not contain any partitioning or placement information. The performance of these macros depends, therefore, on the partitioning and placement obtained during implementation.

RPMs, on the other hand, do contain predetermined partitioning and placement information that permits optimal implementation of these functions. Users can create their own library of soft macros or RPMs based on the macros and primitives in the standard library.

The design environment supports hierarchical design entry, with high-level schematics that comprise major functional blocks, while lower-level schematics define the logic in these blocks. These hierarchical design elements are automatically combined by the implementation tools. Different design entry tools can be combined within a hierarchical design, thus allowing the most convenient entry method to be used for each portion of the design.

### Design Implementation

The place-and-route tools (PAR) automatically provide the implementation flow described in this section. The partitioner takes the EDIF net list for the design and maps the logic into the architectural resources of the FPGA (CLBs and IOBs, for example). The placer then determines the best locations for these blocks based on their interconnec-

tions and the desired performance. Finally, the router interconnects the blocks.

The PAR algorithms support fully automatic implementation of most designs. For demanding applications, however, the user can exercise various degrees of control over the process. User partitioning, placement, and routing information is optionally specified during the design-entry process. The implementation of highly structured designs can benefit greatly from basic floor planning.

The implementation software incorporates Timing Wizard® timing-driven placement and routing. Designers specify timing requirements along entire paths during design entry. The timing path analysis routines in PAR then recognize these user-specified requirements and accommodate them.

Timing requirements are entered on a schematic in a form directly relating to the system requirements, such as the targeted clock frequency, or the maximum allowable delay between two registers. In this way, the overall performance of the system along entire signal paths is automatically tailored to user-generated specifications. Specific timing information for individual nets is unnecessary.

## Configuration

Virtex-E devices are configured by loading configuration data into the internal configuration memory. Note that attempting to load an incorrect bitstream causes configuration to fail and can damage the device.

Some of the pins used for configuration are dedicated pins, while others can be re-used as general purpose inputs and outputs once configuration is complete.

The following are dedicated pins:

- Mode pins (M2, M1, M0)
- Configuration clock pin (CCLK)
- PROGRAM pin
- DONE pin
- Boundary-scan pins (TDI, TDO, TMS, TCK)

Depending on the configuration mode chosen, CCLK can be an output generated by the FPGA, or it can be generated externally and provided to the FPGA as an input. For correct operation, these pins require a  $V_{CC0}$  of 3.3 V to permit LVTTTL operation. All of the pins affected are in banks 2 or 3.

Table 8: Configuration Codes

Configuration Mode	M2	M1	M0	CCLK Direction	Data Width	Serial D <sub>out</sub>	Configuration Pull-ups
Master-serial mode	0	0	0	Out	1	Yes	No
Boundary-scan mode	1	0	1	N/A	1	No	No
SelectMAP mode	1	1	0	In	8	No	No
Slave-serial mode	1	1	1	In	1	Yes	No
Master-serial mode	1	0	0	Out	1	Yes	Yes
Boundary-scan mode	0	0	1	N/A	1	No	Yes
SelectMAP mode	0	1	0	In	8	No	Yes
Slave-serial mode	0	1	1	In	1	Yes	Yes

## Design Verification

In addition to conventional software simulation, FPGA users can use in-circuit debugging techniques. Because Xilinx devices are infinitely reprogrammable, designs can be verified in real time without the need for extensive sets of software simulation vectors.

The development system supports both software simulation and in-circuit debugging techniques. For simulation, the system extracts the post-layout timing information from the design database, and back-annotates this information into the net list for use by the simulator. Alternatively, the user can verify timing-critical portions of the design using the TRCE® static timing analyzer.

For in-circuit debugging, an optional download and read-back cable is available. This cable connects the FPGA in the target system to a PC or workstation. After downloading the design into the FPGA, the designer can single-step the logic, readback the contents of the flip-flops, and so observe the internal logic state. Simple modifications can be downloaded into the system in a matter of minutes.

## Configuration Modes

Virtex-E supports the following four configuration modes.

- Slave-serial mode
- Master-serial mode
- SelectMAP mode
- Boundary-scan mode (JTAG)

The Configuration mode pins (M2, M1, M0) select among these configuration modes with the option in each case of having the IOB pins either pulled up or left floating prior to configuration. The selection codes are listed in Table 8.

Configuration through the boundary-scan port is always available, independent of the mode selection. Selecting the boundary-scan mode simply turns off the other modes. The three mode pins have internal pull-up resistors, and default to a logic High if left unconnected.

Table 9 lists the total number of bits required to configure each device.

Table 9: Virtex-E Bitstream Lengths

Device	# of Configuration Bits
XCV405E	3,430,400
XCV812E	6,519,648

**Slave-Serial Mode**

In slave-serial mode, the FPGA receives configuration data in bit-serial form from a serial PROM or other source of serial configuration data. The serial bitstream must be set up at the DIN input pin a short time before each rising edge of an externally generated CCLK.

For more information on serial PROMs, see the PROM data sheet at <http://www.xilinx.com/partinfo/ds026.pdf>.

Multiple FPGAs can be daisy-chained for configuration from a single source. After a particular FPGA has been config-

ured, the data for the next device is routed to the DOUT pin. Data on the DOUT pin changes on the rising edge of CCLK.

The change of DOUT on the rising edge of CCLK differs from previous families but does not cause a problem for mixed configuration chains. This change was made to improve serial configuration rates for Virtex and Virtex-E only chains.

Figure 13 shows a full master/slave system. A Virtex-E device in slave-serial mode should be connected as shown in the right-most device.

Slave-serial mode is selected by applying <111> or <011> to the mode pins (M2, M1, M0). A weak pull-up on the mode pins makes slave-serial the default mode if the pins are left unconnected. Figure 14 shows slave-serial configuration timing.

Table 10 provides more detail about the characteristics shown in Figure 14. Configuration must be delayed until the INIT pins of all daisy-chained FPGAs are High.

Table 10: Master/Slave Serial Mode Programming Switching

	Description	Figure References	Symbol	Values	Units
CCLK	DIN setup/hold, slave mode	1/2	$T_{DCC}/T_{CCD}$	5.0/0.0	ns, min
	DIN setup/hold, master mode	1/2	$T_{DSCk}/T_{CKDS}$	5.0/0.0	ns, min
	DOUT	3	$T_{CCO}$	12.0	ns, max
	High time	4	$T_{CCH}$	5.0	ns, min
	Low time	5	$T_{CCL}$	5.0	ns, min
	Maximum Frequency		$F_{CC}$	66	MHz, max
	Frequency Tolerance, master mode with respect to nominal			+45% -30%	

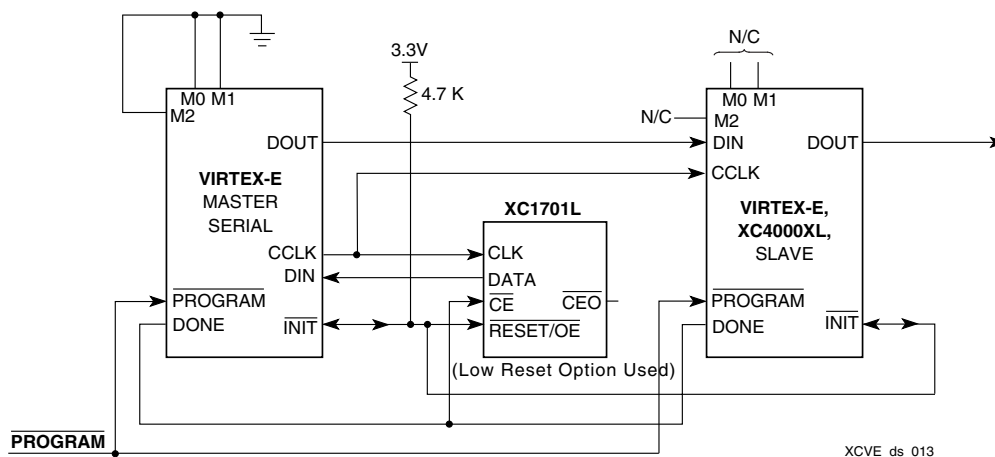

Figure 13: Master/Slave Serial Mode Circuit Diagram

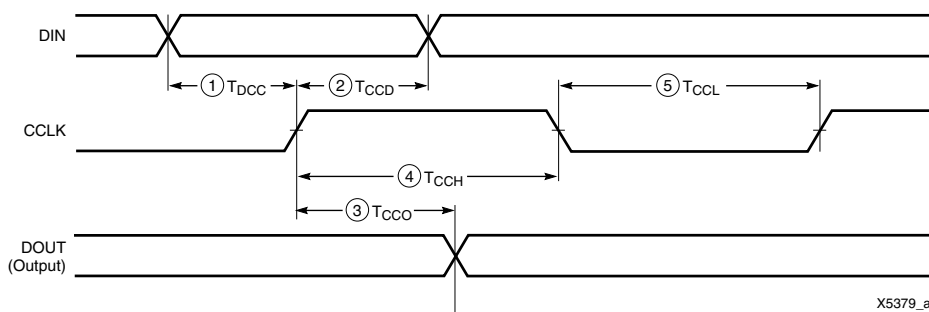

Figure 14: Slave-Serial Mode Programming Switching Characteristics

### Master-Serial Mode

In master-serial mode, the CCLK output of the FPGA drives a Xilinx Serial PROM that feeds bit-serial data to the DIN input. The FPGA accepts this data on each rising CCLK edge. After the FPGA has been loaded, the data for the next device in a daisy-chain is presented on the DOUT pin after the rising CCLK edge.

The interface is identical to slave-serial except that an internal oscillator is used to generate the configuration clock (CCLK). A wide range of frequencies can be selected for CCLK which always starts at a slow default frequency. Configuration bits then switch CCLK to a higher frequency for the remainder of the configuration. Switching to a lower frequency is prohibited.

The CCLK frequency is set using the ConfigRate option in the bitstream generation software. The maximum CCLK frequency that can be selected is 60 MHz. When selecting a CCLK frequency, ensure that the serial PROM and any daisy-chained FPGAs are fast enough to support the clock rate.

On power-up, the CCLK frequency is approximately 2.5 MHz. This frequency is used until the ConfigRate bits have been loaded when the frequency changes to the selected ConfigRate. Unless a different frequency is specified in the design, the default ConfigRate is 4 MHz.

Figure 13 shows a full master/slave system. In this system, the left-most device operates in master-serial mode. The remaining devices operate in slave-serial mode. The SPROM

$\overline{\text{RESET}}$  pin is driven by  $\overline{\text{INIT}}$ , and the  $\overline{\text{CE}}$  input is driven by DONE. There is the potential for contention on the DONE pin, depending on the start-up sequence options chosen.

The sequence of operations necessary to configure a Virtex-E FPGA serially appears in Figure 15.

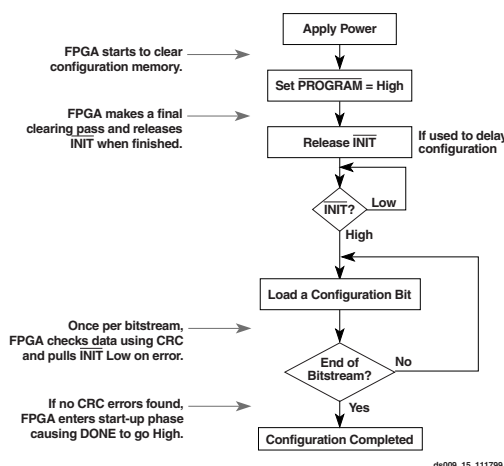

Figure 15: Serial Configuration Flowchart

Figure 16 shows the timing of master-serial configuration. Master-serial mode is selected by a <000> or <100> on the mode pins (M2, M1, M0). Table 10 shows the timing information for Figure 16

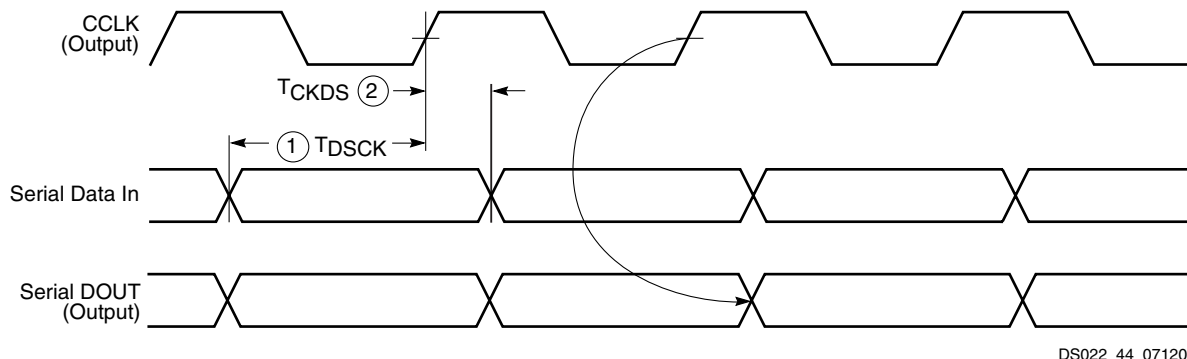

Figure 16: Master-Serial Mode Programming Switching Characteristics



At power-up,  $V_{CC}$  must rise from 1.0 V to  $V_{CC}$  min in less than 50 ms, otherwise delay configuration by pulling  $\overline{PROGRAM}$  Low until  $V_{CC}$  is valid.

### SelectMAP Mode

The SelectMAP mode is the fastest configuration option. Byte-wide data is written into the FPGA with a BUSY flag controlling the flow of data.

An external data source provides a byte stream, CCLK, a Chip Select ( $\overline{CS}$ ) signal and a Write signal ( $\overline{WRITE}$ ). If BUSY is asserted (High) by the FPGA, the data must be held until BUSY goes Low.

Data can also be read using the SelectMAP mode. If  $\overline{WRITE}$  is not asserted, configuration data is read out of the FPGA as part of a readback operation.

After configuration, the pins of the SelectMAP port can be used as additional user I/O. Alternatively, the port can be retained to permit high-speed 8-bit readback.

Retention of the SelectMAP port is selectable on a design-by-design basis when the bitstream is generated. If retention is selected, PROHIBIT constraints are required to prevent SelectMAP-port pins from being used as user I/O.

Multiple Virtex-E FPGAs can be configured using the SelectMAP mode, and be made to start-up simultaneously. To configure multiple devices in this way, wire the individual CCLK, Data,  $\overline{WRITE}$ , and BUSY pins of all the devices in parallel. The individual devices are loaded separately by asserting the  $\overline{CS}$  pin of each device in turn and writing the appropriate data. See [Table 11](#) for SelectMAP Write Timing Characteristics.

**Table 11: SelectMAP Write Timing Characteristics**

	Description		Symbol	Values	Units
CCLK	$D_{0-7}$ Setup/Hold	1/2	$T_{SMDCC}/T_{SMCCD}$	5.0 / 1.0	ns, min
	$\overline{CS}$ Setup/Hold	3/4	$T_{SMCSCC}/T_{SMCCCS}$	7.0 / 1.0	ns, min
	$\overline{WRITE}$ Setup/Hold	5/6	$T_{SMCCW}/T_{SMWCC}$	7.0 / 1.0	ns, min
	BUSY Propagation Delay	7	$T_{SMCKBY}$	12.0	ns, max
	Maximum Frequency		$F_{CC}$	66	MHz, max
	Maximum Frequency with no handshake		$F_{CCNH}$	50	MHz, max

### Write

Write operations send packets of configuration data into the FPGA. The sequence of operations for a multi-cycle write operation is shown below. Note that a configuration packet can be split into many such sequences. The packet does not have to complete within one assertion of  $\overline{CS}$ , illustrated in [Figure 17](#).

1. Assert  $\overline{WRITE}$  and  $\overline{CS}$  Low. Note that when  $\overline{CS}$  is asserted on successive CCLKs,  $\overline{WRITE}$  must remain either asserted or de-asserted. Otherwise an abort is initiated, as described below.
2. Drive data onto D[7:0]. Note that to avoid contention, the data source should not be enabled while  $\overline{CS}$  is Low and  $\overline{WRITE}$  is High. Similarly, while  $\overline{WRITE}$  is High, no more that one  $\overline{CS}$  should be asserted.
3. At the rising edge of CCLK: If BUSY is Low, the data is accepted on this clock. If BUSY is High (from a previous write), the data is not accepted. Acceptance instead occurs on the first clock after BUSY goes Low, and the data must be held until this has happened.
4. Repeat steps 2 and 3 until all the data has been sent.
5. De-assert  $\overline{CS}$  and  $\overline{WRITE}$ .

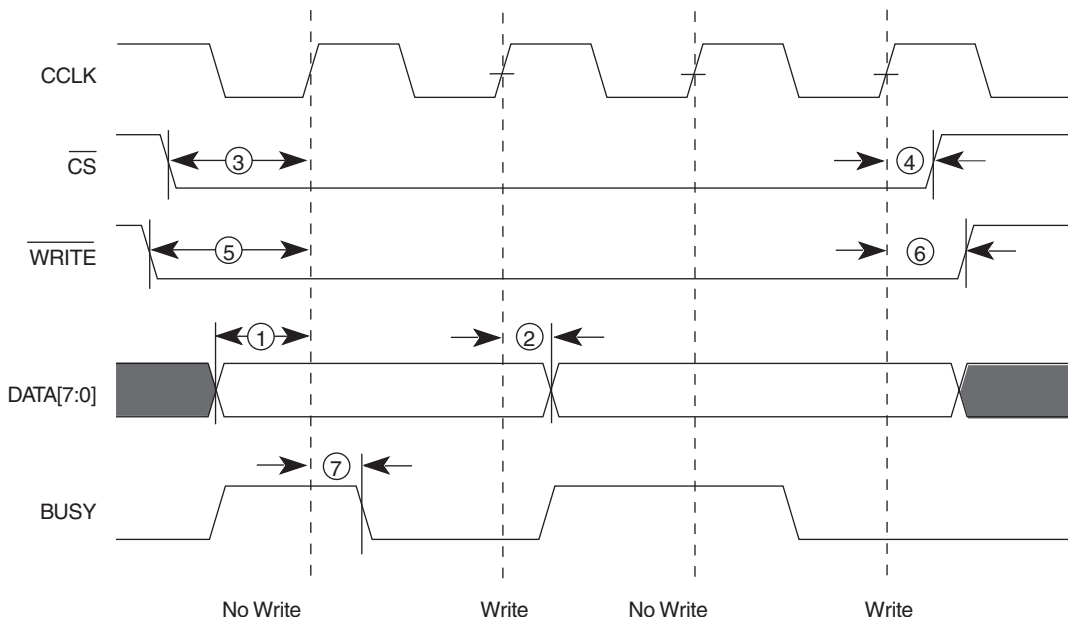

DS022\_45\_071201

Figure 17: Write Operations

A flowchart for the write operation appears in Figure 18. Note that if CCLK is slower than  $f_{CCNH}$ , the FPGA never asserts BUSY. In this case, the above handshake is unnecessary, and data can simply be entered into the FPGA every CCLK cycle.

**Abort**

During a given assertion of  $\overline{CS}$ , the user cannot switch from a write to a read, or vice-versa. This action causes the current packet command to be aborted. The device remains BUSY until the aborted operation has completed. Following an abort, data is assumed to be unaligned to word boundaries, and the FPGA requires a new synchronization word prior to accepting any new packets.

To initiate an abort during a write operation, de-assert  $\overline{WRITE}$ . At the rising edge of CCLK, an abort is initiated, as shown in Figure 19.

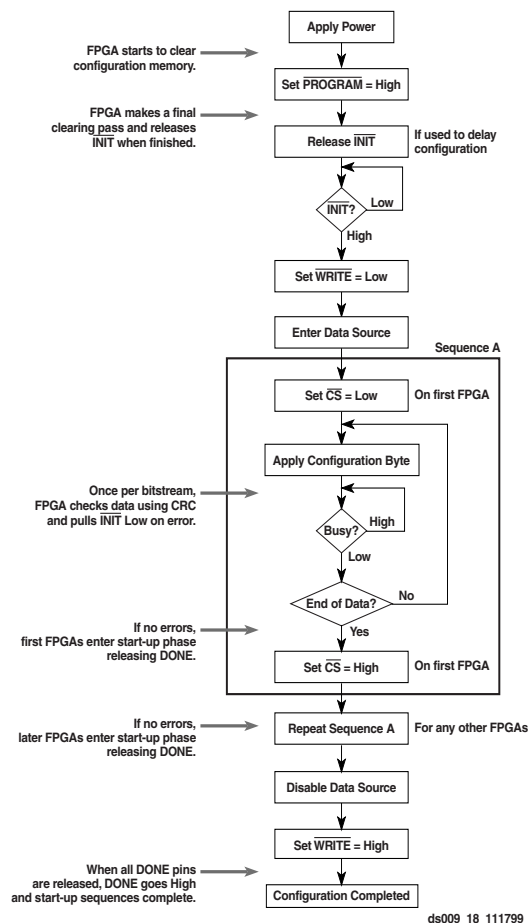

ds009\_18\_111799

Figure 18: SelectMAP Flowchart for Write Operations

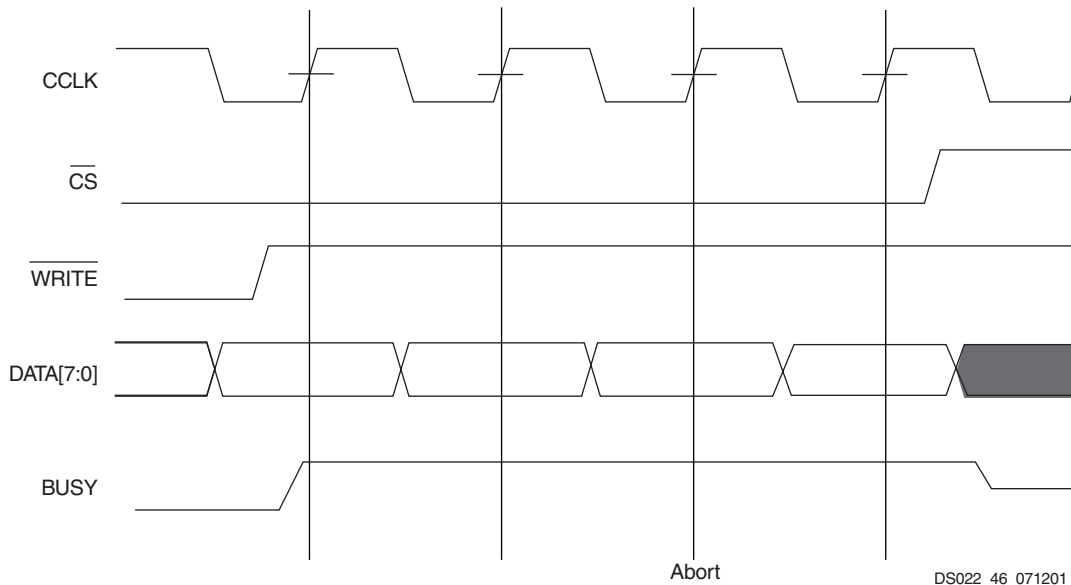

Figure 19: SelectMAP Write Abort Waveforms

### Boundary-Scan Mode

In the boundary-scan mode, no non-dedicated pins are required, configuration being done entirely through the IEEE 1149.1 Test Access Port.

Configuration through the TAP uses the CFG\_IN instruction. This instruction allows data input on TDI to be converted into data packets for the internal configuration bus.

The following steps are required to configure the FPGA through the boundary-scan port (when using TCK as a start-up clock).

1. Load the CFG\_IN instruction into the boundary-scan instruction register (IR)
2. Enter the Shift-DR (SDR) state
3. Shift a configuration bitstream into TDI
4. Return to Run-Test-Idle (RTI)
5. Load the JSTART instruction into IR
6. Enter the SDR state

7. Clock TCK through the startup sequence
8. Return to RTI

Configuration and readback via the TAP is always available. The boundary-scan mode is selected by a <101> or <001> on the mode pins (M2, M1, M0).

### Configuration Sequence

The configuration of Virtex-E devices is a three-phase process. First, the configuration memory is cleared. Next, configuration data is loaded into the memory, and finally, the logic is activated by a start-up process.

Configuration is automatically initiated on power-up unless it is delayed by the user, as described below. The configuration process can also be initiated by asserting PROGRAM. The end of the memory-clearing phase is signalled by INIT going High, and the completion of the entire process is signalled by DONE going High.

The power-up timing of configuration signals is shown in Figure 20.

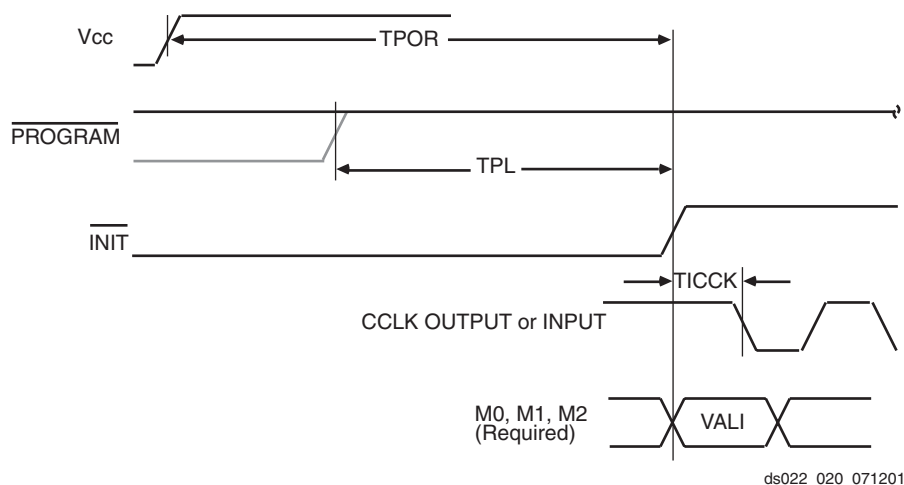

Figure 20: Power-Up Timing Configuration Signals

The corresponding timing characteristics are listed in Table 12.

Table 12: Power-up Timing Characteristics

Description	Symbol	Value	Units
Power-on Reset <sup>1</sup>	$T_{POR}$	2.0	ms, max
Program Latency	$T_{PL}$	100.0	$\mu$ s, max
CCLK (output) Delay	$T_{ICCK}$	0.5	$\mu$ s, min
		4.0	$\mu$ s, max
Program Pulse Width	$T_{PROGRAM}$	300	ns, min

**Notes:**

- $T_{POR}$  delay is the initialization time required after  $V_{CCINT}$  reaches the recommended operating voltage.

**Delaying Configuration**

$\overline{INIT}$  can be held Low using an open-drain driver. An open-drain is required since  $\overline{INIT}$  is a bidirectional open-drain pin that is held Low by the FPGA while the configuration memory is being cleared. Extending the time that the pin is Low causes the configuration sequencer to wait. Thus, configuration is delayed by preventing entry into the phase where data is loaded.

**Readback**

The configuration data stored in the Virtex-E configuration memory can be readback for verification. Along with the configuration data it is possible to readback the contents all flip-flops/latches, LUT RAMs, and block RAMs. This capa-

**Start-Up Sequence**

The default Start-up sequence is that one CCLK cycle after DONE goes High, the global 3-state signal (GTS) is released. This permits device outputs to turn on as necessary.

One CCLK cycle later, the Global Set/Reset (GSR) and Global Write Enable (GWE) signals are released. This permits the internal storage elements to begin changing state in response to the logic and the user clock.

The relative timing of these events can be changed. In addition, the GTS, GSR, and GWE events can be made dependent on the DONE pins of multiple devices all going High, forcing the devices to start synchronously. The sequence can also be paused at any stage until lock has been achieved on any or all DLLs.

bility is used for real-time debugging. For more detailed information, see application note XAPP138 "Virtex FPGA Series Configuration and Readback".

## Design Considerations

This section contains more detailed design information on the following features.

- Delay-Locked Loop . . . see [page 19](#)
- BlockRAM . . . see [page 23](#)
- Select I/O . . . see [page 30](#)

## Using DLLs

The Virtex-E FPGA series provides up to eight fully digital dedicated on-chip Delay-Locked Loop (DLL) circuits which provide zero propagation delay, low clock skew between output clock signals distributed throughout the device, and advanced clock domain control. These dedicated DLLs can be used to implement several circuits which improve and simplify system level design.

## Introduction

As FPGAs grow in size, quality on-chip clock distribution becomes increasingly important. Clock skew and clock delay impact device performance and the task of managing clock skew and clock delay with conventional clock trees becomes more difficult in large devices. The Virtex-E series of devices resolve this potential problem by providing up to eight fully digital dedicated on-chip DLL circuits which provide zero propagation delay and low clock skew between output clock signals distributed throughout the device.

Each DLL can drive up to two global clock routing networks within the device. The global clock distribution network minimizes clock skews due to loading differences. By monitoring a sample of the DLL output clock, the DLL can compensate for the delay on the routing network, effectively eliminating the delay from the external input port to the individual clock loads within the device.

In addition to providing zero delay with respect to a user source clock, the DLL can provide multiple phases of the source clock. The DLL can also act as a clock doubler or it can divide the user source clock by up to 16.

Clock multiplication gives the designer a number of design alternatives. For instance, a 50 MHz source clock doubled by the DLL can drive an FPGA design operating at 100 MHz. This technique can simplify board design because the clock path on the board no longer distributes such a high-speed signal. A multiplied clock also provides designers the option of time-domain-multiplexing, using one circuit twice per clock cycle, consuming less area than two copies of the same circuit. Two DLLs in can be connected in series to increase the effective clock multiplication factor to four.

The DLL can also act as a clock mirror. By driving the DLL output off-chip and then back in again, the DLL can be used to de-skew a board level clock between multiple devices.

In order to guarantee the system clock establishes prior to the device “waking up,” the DLL can delay the completion of the device configuration process until after the DLL achieves lock.

By taking advantage of the DLL to remove on-chip clock delay, the designer can greatly simplify and improve system level design involving high-fanout, high-performance clocks.

## Library DLL Symbols

Figure 21 shows the simplified Xilinx library DLL macro symbol, BUFGDLL. This macro delivers a quick and efficient way to provide a system clock with zero propagation delay throughout the device. Figure 22 and Figure 23 show the two library DLL primitives. These symbols provide access to the complete set of DLL features when implementing more complex applications.

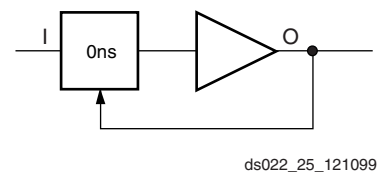

ds022\_25\_121099

Figure 21: Simplified DLL Macro Symbol BUFGDLL

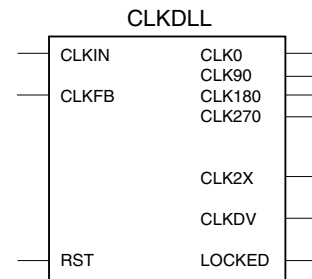

ds022\_26\_121099

Figure 22: Standard DLL Symbol CLKDLL

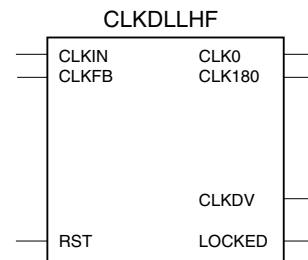

ds022\_027\_121099

Figure 23: High Frequency DLL Symbol

## BUFGDLL Pin Descriptions

Use the BUFGDLL macro as the simplest way to provide zero propagation delay for a high-fanout on-chip clock from an external input. This macro uses the IBUFG, CLKDLL and BUFG primitives to implement the most basic DLL application as shown in Figure 24.

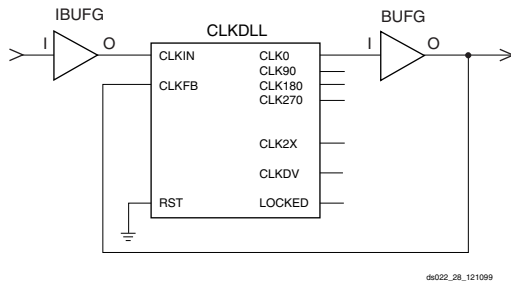

Figure 24: BUFGDLL Schematic

This symbol does not provide access to the advanced clock domain controls or to the clock multiplication or clock division features of the DLL. This symbol also does not provide access to the RST, or LOCKED pins of the DLL. For access to these features, a designer must use the library DLL primitives described in the following sections.

### Source Clock Input — I

The I pin provides the user source clock, the clock signal on which the DLL operates, to the BUFGDLL. For the BUFGDLL macro the source clock frequency must fall in the low frequency range as specified in the data sheet. The BUFGDLL requires an external signal source clock. Therefore, only an external input port can source the signal that drives the BUFGDLL I pin.

### Clock Output — O

The clock output pin O represents a delay-compensated version of the source clock (I) signal. This signal, sourced by a global clock buffer BUFG symbol, takes advantage of the dedicated global clock routing resources of the device.

The output clock has a 50-50 duty cycle unless you deactivate the duty cycle correction property.

## CLKDLL Primitive Pin Descriptions

The library CLKDLL primitives provide access to the complete set of DLL features needed when implementing more complex applications with the DLL.

### Source Clock Input — CLKIN

The CLKIN pin provides the user source clock (the clock signal on which the DLL operates) to the DLL. The CLKIN frequency must fall in the ranges specified in the data sheet. A global clock buffer (BUFG) driven from another CLKDLL, one of the global clock input buffers (IBUFG), or an IO\_LVDS\_DLL pin on the same edge of the device (top or bottom) must source this clock signal. There are four IO\_LVDS\_DLL input pins that can be used as inputs to the

DLLs. This makes a total of eight usable input pins for DLLs in the Virtex-E family.

### Feedback Clock Input — CLKFB

The DLL requires a reference or feedback signal to provide the delay-compensated output. Connect only the CLK0 or CLK2X DLL outputs to the feedback clock input (CLKFB) pin to provide the necessary feedback to the DLL. The feedback clock input can also be provided through one of the following pins.

IBUFG - Global Clock Input Pad

IO\_LVDS\_DLL - the pin adjacent to IBUF

If an IBUFG sources the CLKFB pin, the following special rules apply.

1. An external input port must source the signal that drives the IBUFG I pin.
2. The CLK2X output must feedback to the device if both the CLK0 and CLK2X outputs are driving off chip devices.
3. That signal must directly drive only OBUFs and nothing else.

These rules enable the software determine which DLL clock output sources the CLKFB pin.

### Reset Input — RST

When the reset pin RST activates the LOCKED signal deactivates within four source clock cycles. The RST pin, active High, must either connect to a dynamic signal or tied to ground. As the DLL delay taps reset to zero, glitches can occur on the DLL clock output pins. Activation of the RST pin can also severely affect the duty cycle of the clock output pins. Furthermore, the DLL output clocks no longer de-skew with respect to one another. For these reasons, rarely use the reset pin unless re-configuring the device or changing the input frequency.

### 2x Clock Output — CLK2X

The output pin CLK2X provides a frequency-doubled clock with an automatic 50/50 duty-cycle correction. Until the CLKDLL has achieved lock, the CLK2X output appears as a 1x version of the input clock with a 25/75 duty cycle. This behavior allows the DLL to lock on the correct edge with respect to source clock. This pin is not available on the CLKDLLHF primitive.

### Clock Divide Output — CLKDV

The clock divide output pin CLKDV provides a lower frequency version of the source clock. The CLKDV\_DIVIDE property controls CLKDV such that the source clock is divided by N where N is either 1.5, 2, 2.5, 3, 4, 5, 8, or 16.

This feature provides automatic duty cycle correction such that the CLKDV output pin always has a 50/50 duty cycle, with the exception of noninteger divides in HF mode, where the duty cycle is 1/3 for N=1.5 and 2/5 for N=2.5.



### 1x Clock Outputs — CLK[0|90|180|270]

The 1x clock output pin CLK0 represents a delay-compensated version of the source clock (CLKIN) signal. The CLKDLL primitive provides three phase-shifted versions of the CLK0 signal while CLKDLLHF provides only the 180 phase-shifted version. The relationship between phase shift and the corresponding period shift appears in [Table 13](#).

**Table 13: Relationship of Phase-Shifted Output Clock to Period Shift**

Phase (degrees)	Period Shift (percent)
0	0%
90	25%
180	50%
270	75%

The timing diagrams in [Figure 25](#) illustrate the DLL clock output characteristics.

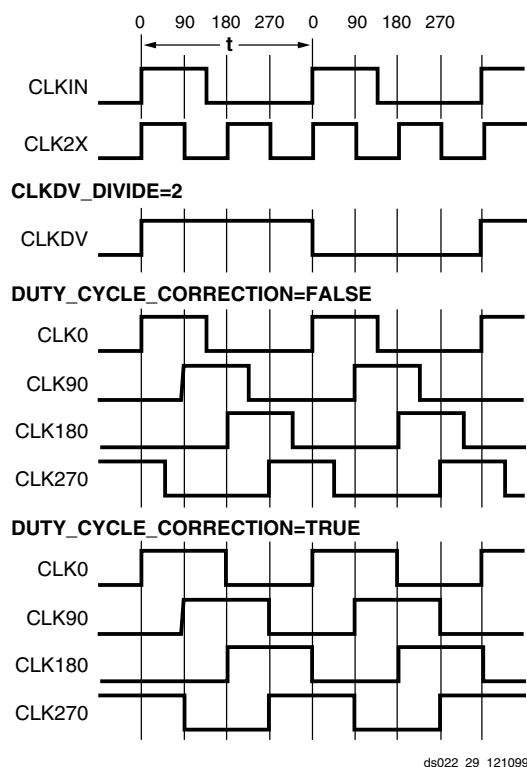

**Figure 25: DLL Output Characteristics**

The DLL provides duty cycle correction on all 1x clock outputs such that all 1x clock outputs by default have a 50/50 duty cycle. The DUTY\_CYCLE\_CORRECTION property (TRUE by default), controls this feature. In order to deactivate the DLL duty cycle correction, attach the DUTY\_CYCLE\_CORRECTION=FALSE property to the DLL symbol. When duty cycle correction deactivates, the output clock has the same duty cycle as the source clock.

The DLL clock outputs can drive an OBUF, a BUFG, or they can route directly to destination clock pins. The DLL clock outputs can only drive the BUFGs that reside on the same edge (top or bottom).

### Locked Output — LOCKED

To achieve lock, the DLL might need to sample several thousand clock cycles. After the DLL achieves lock, the LOCKED signal activates. The DLL timing parameter section of the data sheet provides estimates for locking times.

To guarantee that the system clock is established prior to the device “waking up,” the DLL can delay the completion of the device configuration process until after the DLL locks. The STARTUP\_WAIT property activates this feature.

Until the LOCKED signal activates, the DLL output clocks are not valid and can exhibit glitches, spikes, or other spurious movement. In particular the CLK2X output appears as a 1x clock with a 25/75 duty cycle.

### DLL Properties

Properties provide access to some of the Virtex-E series DLL features, (for example, clock division and duty cycle correction).

#### Duty Cycle Correction Property

The 1x clock outputs, CLK0, CLK90, CLK180, and CLK270, use the duty-cycle corrected default, exhibiting a 50/50 duty cycle. The DUTY\_CYCLE\_CORRECTION property (by default TRUE) controls this feature. To deactivate the DLL duty-cycle correction for the 1x clock outputs, attach the DUTY\_CYCLE\_CORRECTION=FALSE property to the DLL symbol. When duty-cycle correction deactivates, the output clock has the same duty cycle as the source clock.

#### Clock Divide Property

The CLKDV\_DIVIDE property specifies how the signal on the CLKDV pin is frequency divided with respect to the CLK0 pin. The values allowed for this property are 1.5, 2, 2.5, 3, 4, 5, 8, or 16; the default value is 2.

#### Startup Delay Property

This property, STARTUP\_WAIT, takes on a value of TRUE or FALSE (the default value). When TRUE the device configuration DONE signal waits until the DLL locks before going to High.

### Virtex-E DLL Location Constraints

As shown in [Figure 26](#), there are four additional DLLs in the Virtex-E devices, for a total of eight per Virtex-E device. These DLLs are located in silicon, at the top and bottom of the two innermost block SelectRAM columns. The location constraint LOC, attached to the DLL symbol with the identifier DLL0S, DLL0P, DLL1S, DLL1P, DLL2S, DLL2P, DLL3S, or DLL3P, controls the DLL location.

The LOC property uses the following form:

$$LOC = DLL0P$$

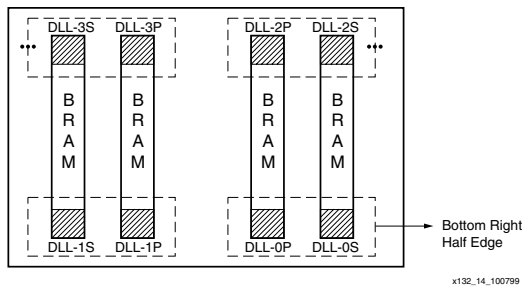

Figure 26: Virtex Series DLLs

## Design Factors

Use the following design considerations to avoid pitfalls and improve success designing with Xilinx devices.

### Input Clock

The output clock signal of a DLL, essentially a delayed version of the input clock signal, reflects any instability on the input clock in the output waveform. For this reason the quality of the DLL input clock relates directly to the quality of the output clock waveforms generated by the DLL. The DLL input clock requirements are specified in the data sheet.

In most systems a crystal oscillator generates the system clock. The DLL can be used with any commercially available quartz crystal oscillator. For example, most crystal oscillators produce an output waveform with a frequency tolerance of 100 PPM, meaning 0.01 percent change in the clock period. The DLL operates reliably on an input waveform with a frequency drift of up to 1 ns — orders of magnitude in excess of that needed to support any crystal oscillator in the industry. However, the cycle-to-cycle jitter must be kept to less than 300 ps in the low frequencies and 150 ps for the high frequencies.

### Input Clock Changes

Changing the period of the input clock beyond the maximum drift amount requires a manual reset of the CLKDLL. Failure to reset the DLL produces an unreliable lock signal and output clock.

It is possible to stop the input clock with little impact to the DLL. Stopping the clock should be limited to less than 100  $\mu$ s to keep device cooling to a minimum. The clock should be stopped during a Low phase, and when restored the full High period should be seen. During this time LOCKED stays High and remains High when the clock is restored.

When the clock is stopped, one to four more clocks are still observed as the delay line is flushed. When the clock is restarted, the output clocks are not observed for one to four clocks as the delay line is filled. The most common case is two or three clocks.

In a similar manner, a phase shift of the input clock is also possible. The phase shift propagates one to four clocks to the output after the original shift, with no disruption to the CLKDLL control.

### Output Clocks

As mentioned earlier in the DLL pin descriptions, some restrictions apply regarding the connectivity of the output pins. The DLL clock outputs can drive an OBUF, a global clock buffer BUFG, or they can route directly to destination clock pins. The only BUFGs that the DLL clock outputs can drive are the two on the same edge of the device (top or bottom). In addition, the CLK2X output of the secondary DLL can connect directly to the CLKIN of the primary DLL in the same quadrant.

Do not use the DLL output clock signals until after activation of the LOCKED signal. Prior to the activation of the LOCKED signal, the DLL output clocks are not valid and can exhibit glitches, spikes, or other spurious movement.

## Useful Application Examples

The Virtex-E DLL can be used in a variety of creative and useful applications. The following examples show some of the more common applications. The Verilog and VHDL example files are available at:

<ftp://ftp.xilinx.com/pub/applications/xapp/xapp132.zip>

### Standard Usage

The circuit shown in Figure 27 resembles the BUFGDLL macro implemented to provide access to the RST and LOCKED pins of the CLKDLL.

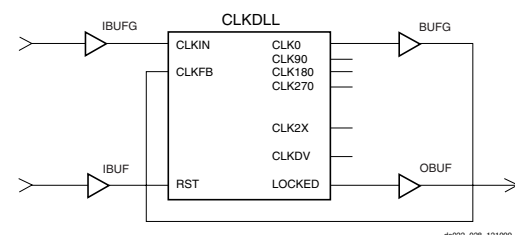

Figure 27: Standard DLL Implementation

## Board Level De-Skew of Multiple Non-Virtex-E Devices

The circuit shown in Figure 28 can be used to de-skew a system clock between a Virtex-E chip and other non-Virtex-E chips on the same board. This application is commonly used when the Virtex-E device is used in conjunction with other standard products such as SRAM or DRAM devices. While designing the board level route, ensure that the return net delay to the source equals the delay to the other chips involved.

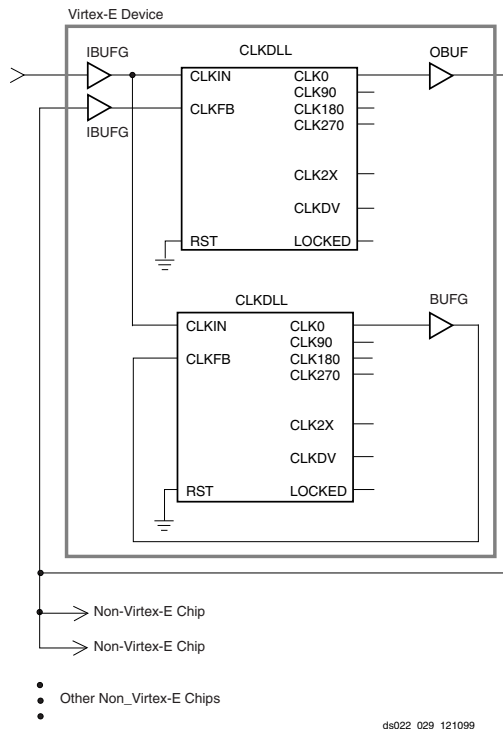

Figure 28: DLL De-skew of Board Level Clock

Board-level de-skew is not required for low-fanout clock networks. It is recommended for systems that have fanout limitations on the clock network, or if the clock distribution chip cannot handle the load.

Do not use the DLL output clock signals until after activation of the LOCKED signal. Prior to the activation of the LOCKED signal, the DLL output clocks are not valid and can exhibit glitches, spikes, or other spurious movement.

The dll\_mirror\_1 files in the xapp132.zip file show the VHDL and Verilog implementation of this circuit.

### De-Skew of Clock and Its 2x Multiple

The circuit shown in Figure 29 implements a 2x clock multiplier and also uses the CLK0 clock output with zero ns skew between registers on the same chip. A clock divider circuit could alternatively be implemented using similar connections.

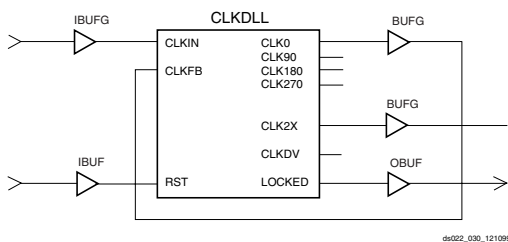

Figure 29: DLL De-skew of Clock and 2x Multiple

Because any single DLL can access only two BUFs at most, any additional output clock signals must be routed from the DLL in this example on the high speed backbone routing.

The dll\_2x files in the xapp132.zip file show the VHDL and Verilog implementation of this circuit.

### Virtex-E 4x Clock

Two DLLs located in the same half-edge (top-left, top-right, bottom-right, bottom-left) can be connected together, without using a BUFG between the CLKDLLs, to generate a 4x clock as shown in Figure 30. Virtex-E devices, like the Virtex devices, have four clock networks that are available for internal de-skewing of the clock. Each of the eight DLLs have access to two of the four clock networks. Although all the DLLs can be used for internal de-skewing, the presence of two GCLKBUFs on the top and two on the bottom indicate that only two of the four DLLs on the top (and two of the four DLLs on the bottom) can be used for this purpose.

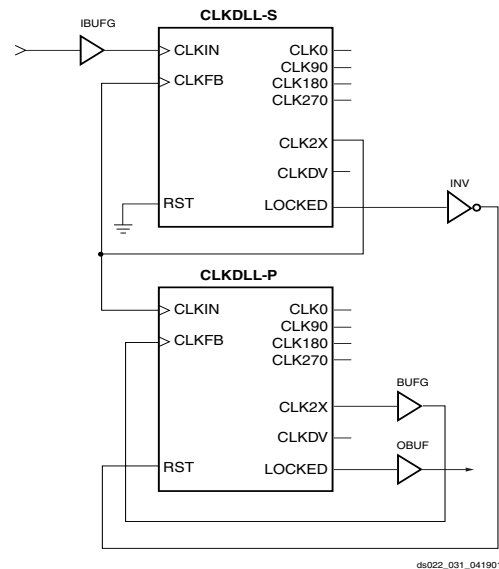

Figure 30: DLL Generation of 4x Clock in Virtex-E Devices

The dll\_4xe files in the xapp 32.zip file show the DLL implementation in Verilog for Virtex-E devices. These files can be found at:

<http://ftp.xilinx.com/pub/applications/xapp/xapp132.zip>

### Using Block SelectRAM+ Features

The Virtex FPGA Series provides dedicated blocks of on-chip, true dual-read/write port synchronous RAM, with 4096 memory cells. Each port of the block SelectRAM+ memory can be independently configured as a read/write port, a read port, a write port, and can be configured to a specific data width. block SelectRAM+ memory offers new capabilities, allowing FPGA designers to simplify designs.

## Operating Modes

Virtex-E block SelectRAM+ memory supports two operating modes.

- Read Through
- Write Back

### Read Through (one clock edge)

The read address is registered on the read port clock edge and data appears on the output after the RAM access time. Some memories might place the latch/register at the outputs, depending on the desire to have a faster clock-to-out versus set-up time. This is generally considered to be an inferior solution, since it changes the read operation to an asynchronous function with the possibility of missing an address/control line transition during the generation of the read pulse clock.

### Write Back (one clock edge)

The write address is registered on the write port clock edge and the data input is written to the memory and mirrored on the output.

## Block SelectRAM+ Characteristics

1. All inputs are registered with the port clock and have a set-up to clock timing specification.
2. All outputs have a read through or write back function depending on the state of the port WE pin. The outputs relative to the port clock are available after the clock-to-out timing specification.
3. The block SelectRAM elements are true SRAM memories and do not have a combinatorial path from the address to the output. The LUT SelectRAM+ cells in the CLBs are still available with this function.
4. The ports are completely independent from each other (*i.e.*, clocking, control, address, read/write function, and data width) without arbitration.
5. A write operation requires only one clock edge.
6. A read operation requires only one clock edge.

The output ports are latched with a self-timed circuit to guarantee a glitch-free read. The state of the output port does not change until the port executes another read or write operation.

## Library Primitives

Figure 31 and Figure 32 show the two generic library block SelectRAM+ primitives. Table 14 describes all of the available primitives for synthesis and simulation.

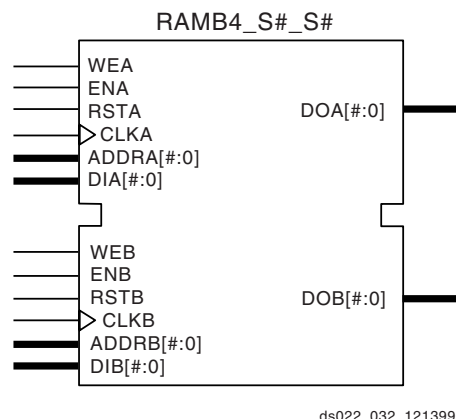

Figure 31: Dual-Port Block SelectRAM+ Memory

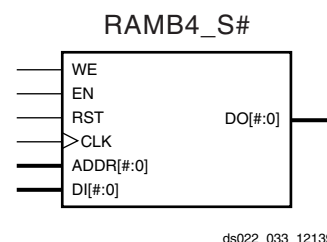

Figure 32: Single-Port Block SelectRAM+ Memory

Table 14: Available Library Primitives

Primitive	Port A Width	Port B Width
RAMB4_S1	1	N/A
RAMB4_S1_S1		1
RAMB4_S1_S2		2
RAMB4_S1_S4		4
RAMB4_S1_S8		8
RAMB4_S1_S16		16
RAMB4_S2	2	N/A
RAMB4_S2_S2		2
RAMB4_S2_S4		4
RAMB4_S2_S8		8
RAMB4_S2_S16		16
RAMB4_S4	4	N/A
RAMB4_S4_S4		4
RAMB4_S4_S8		8
RAMB4_S4_S16		16
RAMB4_S8	8	N/A
RAMB4_S8_S8		8
RAMB4_S8_S16		16
RAMB4_S16	16	N/A
RAMB4_S16_S16		16

## Port Signals

Each block SelectRAM+ port operates independently of the others while accessing the same set of 4096 memory cells.

Table 15 describes the depth and width aspect ratios for the block SelectRAM+ memory.

Table 15: Block SelectRAM+ Port Aspect Ratios

Width	Depth	ADDR Bus	Data Bus
1	4096	ADDR<11:0>	DATA<0>
2	2048	ADDR<10:0>	DATA<1:0>
4	1024	ADDR<9:0>	DATA<3:0>
8	512	ADDR<8:0>	DATA<7:0>
16	256	ADDR<7:0>	DATA<15:0>

### Clock—CLK[AIB]

Each port is fully synchronous with independent clock pins. All port input pins have setup time referenced to the port CLK pin. The data output bus has a clock-to-out time referenced to the CLK pin.

### Enable—EN[AIB]

The enable pin affects the read, write and reset functionality of the port. Ports with an inactive enable pin keep the output pins in the previous state and do not write data to the memory cells.

### Write Enable—WE[AIB]

Activating the write enable pin allows the port to write to the memory cells. When active, the contents of the data input bus are written to the RAM at the address pointed to by the address bus, and the new data also reflects on the data out bus. When inactive, a read operation occurs and the contents of the memory cells referenced by the address bus reflect on the data out bus.

### Reset—RST[AIB]

The reset pin forces the data output bus latches to zero synchronously. This does not affect the memory cells of the RAM and does not disturb a write operation on the other port.

### Address Bus—ADDR[AIB]<#:0>

The address bus selects the memory cells for read or write. The width of the port determines the required width of this bus as shown in Table 15.

### Data In Bus—DI[AIB]<#:0>

The data in bus provides the new data value to be written into the RAM. This bus and the port have the same width, as shown in Table 15.

### Data Output Bus—DO[AIB]<#:0>

The data out bus reflects the contents of the memory cells referenced by the address bus at the last active clock edge. During a write operation, the data out bus reflects the data in bus. The width of this bus equals the width of the port. The allowed widths appear in Table 15.

### Inverting Control Pins

The four control pins (CLK, EN, WE and RST) for each port have independent inversion control as a configuration option.

### Address Mapping

Each port accesses the same set of 4096 memory cells using an addressing scheme dependent on the width of the port. The physical RAM location addressed for a particular width are described in the following formula (of interest only when the two ports use different aspect ratios).

$$\text{Start} = ((\text{ADDR}_{\text{port}} + 1) * \text{Width}_{\text{port}}) - 1$$

$$\text{End} = \text{ADDR}_{\text{port}} * \text{Width}_{\text{port}}$$

Table 16 shows low order address mapping for each port width.

Table 16: Port Address Mapping

Port Width	Port Addresses																
	16	15	14	13	12	11	10	9	8	7	6	5	4	3	2	1	0
1	4095...	5	4	3	2	1	0	9	8	7	6	5	4	3	2	1	0
2	2047...	07		06		05		04		03		02		01		00	
4	1023...	03				02				01				00			
8	511...	01								00							
16	255...	00															

### Creating Larger RAM Structures

The block SelectRAM+ columns have specialized routing to allow cascading blocks together with minimal routing delays. This achieves wider or deeper RAM structures with a smaller timing penalty than when using normal routing channels.

### Location Constraints

Block SelectRAM+ instances can have LOC properties attached to them to constrain the placement. The block SelectRAM+ placement locations are separate from the CLB location naming convention, allowing the LOC properties to transfer easily from array to array.

The LOC properties use the following form.

$$\text{LOC} = \text{RAMB4\_R\#C\#}$$

RAMB4\_R0C0 is the upper left RAMB4 location on the device.



## Conflict Resolution

The block SelectRAM+ memory is a true dual-read/write port RAM that allows simultaneous access of the same memory cell from both ports. When one port writes to a given memory cell, the other port must not address that memory cell (for a write or a read) within the clock-to-clock setup window. The following lists specifics of port and memory cell write conflict resolution.

- If both ports write to the same memory cell simultaneously, violating the clock-to-clock setup requirement, consider the data stored as invalid.
- If one port attempts a read of the same memory cell the other simultaneously writes, violating the clock-to-clock setup requirement, the following occurs.
  - The write succeeds
  - The data out on the writing port accurately reflects the data written.
  - The data out on the reading port is invalid.

Conflicts do not cause any physical damage.

### Single Port Timing

**Figure 33** shows a timing diagram for a single port of a block SelectRAM+ memory. The block SelectRAM+ AC switching characteristics are specified in the data sheet. The block SelectRAM+ memory is initially disabled.

At the first rising edge of the CLK pin, the ADDR, DI, EN, WE, and RST pins are sampled. The EN pin is High and the WE pin is Low indicating a read operation. The DO bus contains the contents of the memory location, 0x00, as indicated by the ADDR bus.

At the second rising edge of the CLK pin, the ADDR, DI, EN, WR, and RST pins are sampled again. The EN and WE pins are High indicating a write operation. The DO bus mirrors the DI bus. The DI bus is written to the memory location 0x0F.

At the third rising edge of the CLK pin, the ADDR, DI, EN, WR, and RST pins are sampled again. The EN pin is High

and the WE pin is Low indicating a read operation. The DO bus contains the contents of the memory location 0x7E as indicated by the ADDR bus.

At the fourth rising edge of the CLK pin, the ADDR, DI, EN, WR, and RST pins are sampled again. The EN pin is Low indicating that the block SelectRAM+ memory is now disabled. The DO bus retains the last value.

### Dual Port Timing

**Figure 34** shows a timing diagram for a true dual-port read/write block SelectRAM+ memory. The clock on port A has a longer period than the clock on Port B. The timing parameter  $T_{BCCS}$ , (clock-to-clock set-up) is shown on this diagram. The parameter,  $T_{BCCS}$  is violated once in the diagram. All other timing parameters are identical to the single port version shown in **Figure 33**.

$T_{BCCS}$  is only of importance when the address of both ports are the same and at least one port is performing a write operation. When the clock-to-clock set-up parameter is violated for a WRITE-WRITE condition, the contents of the memory at that location are invalid. When the clock-to-clock set-up parameter is violated for a WRITE-READ condition, the contents of the memory are correct, but the read port has invalid data. At the first rising edge of CLKA, memory location 0x00 is to be written with the value 0xAAAA and is mirrored on the DOA bus. The last operation of Port B was a read to the same memory location 0x00. The DOB bus of Port B does not change with the new value on Port A, and retains the last read value. A short time later, Port B executes another read to memory location 0x00, and the DOB bus now reflects the new memory value written by Port A.

At the second rising edge of CLKA, memory location 0x7E is written with the value 0x9999 and is mirrored on the DOA bus. Port B then executes a read operation to the same memory location without violating the  $T_{BCCS}$  parameter and the DOB reflects the new memory values written by Port A.



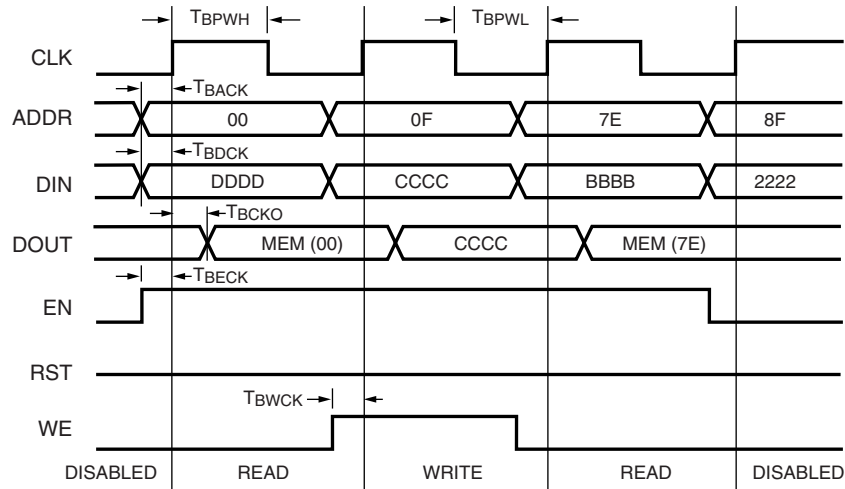

ds022\_0343\_121399

Figure 33: Timing Diagram for Single Port Block SelectRAM+ Memory

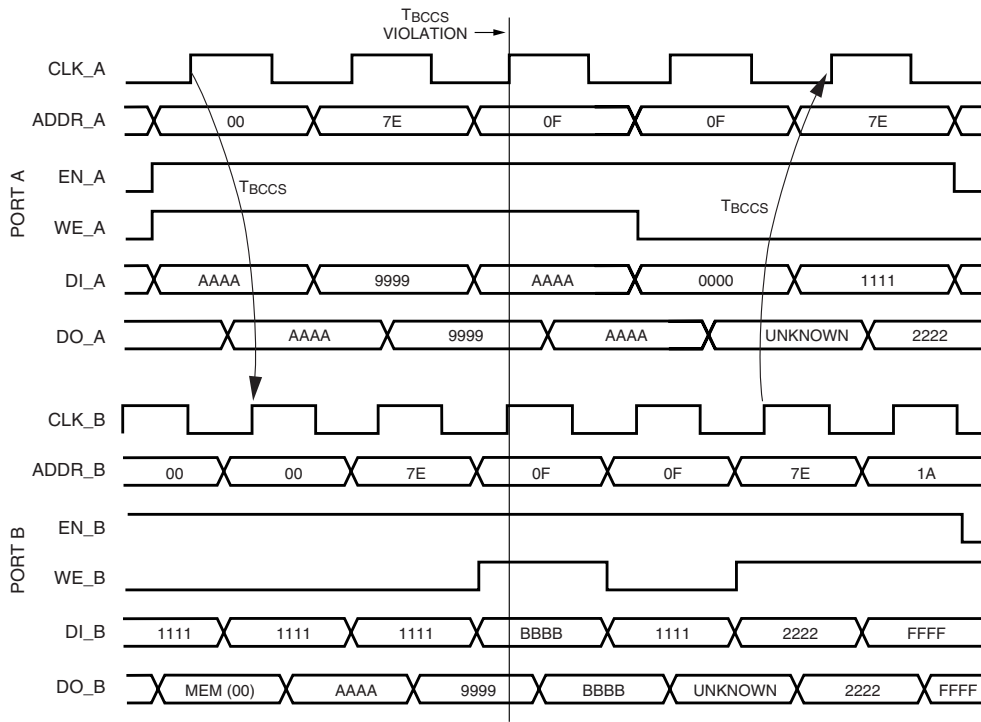

ds022\_035\_121399

Figure 34: Timing Diagram for a True Dual-port Read/Write Block SelectRAM+ Memory

At the third rising edge of CLKA, the  $T_{BCCS}$  parameter is violated with two writes to memory location 0x0F. The DOA and DOB busses reflect the contents of the DIA and DIB busses, but the stored value at 0x0F is invalid.

At the fourth rising edge of CLKA, a read operation is performed at memory location 0x0F and invalid data is present

on the DOA bus. Port B also executes a read operation to memory location 0x0F and also reads invalid data.

At the fifth rising edge of CLKA a read operation is performed that does not violate the  $T_{BCCS}$  parameter to the previous write of 0x7E by Port B. The DOA bus reflects the recently written value by Port B.

## Initialization

The block SelectRAM+ memory can initialize during the device configuration sequence. The 16 initialization properties of 64 hex values each (a total of 4096 bits) set the initialization of each RAM. These properties appear in [Table 17](#). Any initialization properties not explicitly set configure as zeros. Partial initialization strings pad with zeros. Initialization strings greater than 64 hex values generate an error. The RAMs can be simulated with the initialization values using generics in VHDL simulators and parameters in Verilog simulators.

## Initialization in VHDL and Synopsys

The block SelectRAM+ structures can be initialized in VHDL for both simulation and synthesis for inclusion in the EDIF output file. The simulation of the VHDL code uses a generic to pass the initialization. Synopsys FPGA compiler does not presently support generics. The initialization values instead attach as attributes to the RAM by a built-in Synopsys `dc_script`. The `translate_off` statement stops synthesis translation of the generic statements. The following code illustrates a module that employs these techniques.

Table 17: RAM Initialization Properties

Property	Memory Cells
INIT_00	255 to 0
INIT_01	511 to 256
INIT_02	767 to 512
INIT_03	1023 to 768
INIT_04	1279 to 1024
INIT_05	1535 to 1280
INIT_06	1791 to 2047
INIT_07	2047 to 1792
INIT_08	2303 to 2048
INIT_09	2559 to 2304
INIT_0a	2815 to 2560
INIT_0b	3071 to 2816
INIT_0c	3327 to 3072
INIT_0d	3583 to 3328
INIT_0e	3839 to 3584
INIT_0f	4095 to 3840

## Initialization in Verilog and Synopsys

The block SelectRAM+ structures can be initialized in Verilog for both simulation and synthesis for inclusion in the EDIF output file. The simulation of the Verilog code uses a `defparam` to pass the initialization. The Synopsys FPGA compiler does not presently support `defparam`. The initialization values instead attach as attributes to the RAM by a built-in Synopsys `dc_script`. The `translate_off` statement stops synthesis translation of the `defparam` statements. The following code illustrates a module that employs these techniques.

## Design Examples

### Creating a 32-bit Single-Port RAM

The true dual-read/write port functionality of the block SelectRAM+ memory allows a single port, 128 deep by 32-bit wide RAM to be created using a single block SelectRAM+ cell as shown in [Table 35](#).

Interleaving the memory space, setting the LSB of the address bus of Port A to 1 ( $V_{CC}$ ), and the LSB of the address bus of Port B to 0 (GND), allows a 32-bit wide single port RAM to be created.

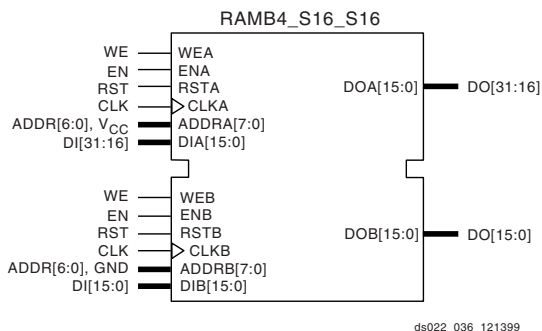

Figure 35: Single Port 128 x 32 RAM

### Creating Two Single-Port RAMs

The true dual-read/write port functionality of the block SelectRAM+ memory allows a single RAM to be split into two single port memories of 2K bits each as shown in [Figure 36](#).

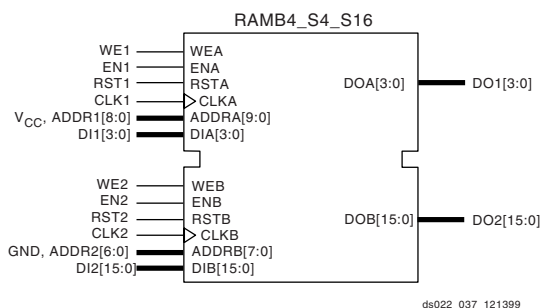

Figure 36: 512 x 4 RAM and 128 x 16 RAM

In this example, a 512K x 4 RAM (Port A) and a 128 x 16 RAM (Port B) are created out of a single block SelectRAM+. The address space for the RAM is split by fixing the MSB of Port A to 1 ( $V_{CC}$ ) for the upper 2K bits and the MSB of Port B to 0 (GND) for the lower 2K bits.

## Block Memory Generation

The CoreGen program generates memory structures using the block SelectRAM+ features. This program outputs VHDL or Verilog simulation code templates and an EDIF file for inclusion in a design.



## Verilog Initialization Example

```

module MYMEM (CLK, WE, ADDR, DIN, DOUT);
input CLK, WE;
input [8:0] ADDR;
input [7:0] DIN;
output [7:0] DOUT;

wire logic0, logic1;

//synopsys dc_script_begin
//set_attribute ram0 INIT_00
"0123456789ABCDEF0123456789ABCDEF0123456789ABCDEF0123456789ABCDEF" -type string
//set_attribute ram0 INIT_01
"FEDCBA9876543210FEDCBA9876543210FEDCBA9876543210FEDCBA9876543210" -type string
//synopsys dc_script_end

assign logic0 = 1'b0;
assign logic1 = 1'b1;

RAMB4_S8 ram0 (.WE(WE), .EN(logic1), .RST(logic0), .CLK(CLK), .ADDR(ADDR), .DI(DIN),
.DO(DOUT));
//synopsys translate_off
defparam ram0.INIT_00 =
256h'0123456789ABCDEF0123456789ABCDEF0123456789ABCDEF0123456789ABCDEF;
defparam ram0.INIT_01 =
256h'FEDCBA9876543210FEDCBA9876543210FEDCBA9876543210FEDCBA9876543210;
//synopsys translate_on
endmodule

```

## Using Select I/O

The Virtex-E FPGA series includes a highly configurable, high-performance I/O resource, called SelectI/O™ to provide support for a wide variety of I/O standards. The SelectI/O resource is a robust set of features including programmable control of output drive strength, slew rate, and input delay and hold time. Taking advantage of the flexibility and SelectI/O features and the design considerations described in this document can improve and simplify system level design.

### Introduction

As FPGAs continue to grow in size and capacity, the larger and more complex systems designed for them demand an increased variety of I/O standards. Furthermore, as system clock speeds continue to increase, the need for high performance I/O becomes more important. While chip-to-chip delays have an increasingly substantial impact on overall system speed, the task of achieving the desired system performance becomes more difficult with the proliferation of low-voltage I/O standards.

SelectI/O, the revolutionary input/output resource of Virtex-E devices, has resolved this potential problem by providing a highly configurable, high-performance alternative to the I/O resources of more conventional programmable devices. The Virtex-E SelectI/O features combine the flexibility and time-to-market advantages of programmable logic

with the high performance previously available only with ASICs and custom ICs.

Each SelectI/O block can support up to 20 I/O standards. Supporting such a variety of I/O standards allows the support of a wide variety of applications, from general purpose standard applications to high-speed low-voltage memory busses.

SelectI/O blocks also provide selectable output drive strengths and programmable slew rates for the LVTTTL output buffers, as well as an optional, programmable weak pull-up, weak pull-down, or weak “keeper” circuit ideal for use in external bussing applications.

Each input/output block (IOB) includes three registers, one each for the input, output, and 3-state signals within the IOB. These registers are optionally configurable as either a D-type flip-flop or as a level sensitive latch.

The input buffer has an optional delay element used to guarantee a zero hold time requirement for input signals registered within the IOB.

The Virtex-E SelectI/O features also provide dedicated resources for input reference voltage ( $V_{REF}$ ) and output source voltage ( $V_{CCO}$ ), along with a convenient banking system that simplifies board design.

By taking advantage of the built-in features and wide variety of I/O standards supported by the SelectI/O features, system-level design and board design can be greatly simplified and improved.

## Fundamentals

Modern bus applications, pioneered by the largest and most influential companies in the digital electronics industry, are commonly introduced with a new I/O standard tailored specifically to the needs of that application. The bus I/O standards provide specifications to other vendors who create products designed to interface with these applications. Each standard often has its own specifications for current, voltage, I/O buffering, and termination techniques.

The ability to provide the flexibility and time-to-market advantages of programmable logic is increasingly dependent on the capability of the programmable logic device to support an ever increasing variety of I/O standards

The SelectI/O resources feature highly configurable input and output buffers which provide support for a wide variety of I/O standards. As shown in [Table 18](#), each buffer type can support a variety of voltage requirements.

Table 18: Virtex-E Supported I/O Standards

I/O Standard	Output $V_{CCO}$	Input $V_{CCO}$	Input $V_{REF}$	Board Termination Voltage ( $V_{TT}$ )
LVTTTL	3.3	3.3	N/A	N/A
LVC MOS2	2.5	2.5	N/A	N/A
LVC MOS18	1.8	1.8	N/A	N/A
SSTL3 I & II	3.3	N/A	1.50	1.50
SSTL2 I & II	2.5	N/A	1.25	1.25
GTL	N/A	N/A	0.80	1.20
GTL+	N/A	N/A	1.0	1.50
HSTL I	1.5	N/A	0.75	0.75
HSTL III & IV	1.5	N/A	0.90	1.50
CTT	3.3	N/A	1.50	1.50
AGP-2X	3.3	N/A	1.32	N/A
PCI33_3	3.3	3.3	N/A	N/A
PCI66_3	3.3	3.3	N/A	N/A
BLVDS & LVDS	2.5	N/A	N/A	N/A
LVPECL	3.3	N/A	N/A	N/A

## Overview of Supported I/O Standards

This section provides a brief overview of the I/O standards supported by all Virtex-E devices.

While most I/O standards specify a range of allowed voltages, this document records typical voltage values only. Detailed information on each specification can be found on the Electronic Industry Alliance Jedec website at:

<http://www.jedec.org>

### LVTTTL — Low-Voltage TTL

The Low-Voltage TTL, or LVTTTL standard is a general purpose EIA/JESDSA standard for 3.3 V applications that uses an LVTTTL input buffer and a Push-Pull output buffer. This standard requires a 3.3 V output source voltage ( $V_{CCO}$ ), but does not require the use of a reference voltage ( $V_{REF}$ ) or a termination voltage ( $V_{TT}$ ).

### LVC MOS2 — Low-Voltage CMOS for 2.5 Volts

The Low-Voltage CMOS for 2.5 Volts or lower, or LVC MOS2 standard is an extension of the LVC MOS standard (JESD 8.-5) used for general purpose 2.5 V applications. This standard requires a 2.5 V output source voltage ( $V_{CCO}$ ), but does not require the use of a reference voltage ( $V_{REF}$ ) or a board termination voltage ( $V_{TT}$ ).

### LVC MOS18 — 1.8 V Low Voltage CMOS

This standard is an extension of the LVC MOS standard. It is used in general purpose 1.8 V applications. The use of a reference voltage ( $V_{REF}$ ) or a board termination voltage ( $V_{TT}$ ) is not required.

### PCI — Peripheral Component Interface

The Peripheral Component Interface, or PCI standard specifies support for both 33 MHz and 66 MHz PCI bus applications. It uses a LVTTTL input buffer and a Push-Pull output buffer. This standard does not require the use of a reference voltage ( $V_{REF}$ ) or a board termination voltage ( $V_{TT}$ ), however, it does require a 3.3 V output source voltage ( $V_{CCO}$ ).

### GTL — Gunning Transceiver Logic Terminated

The Gunning Transceiver Logic, or GTL standard is a high-speed bus standard (JESD8.3) invented by Xerox. Xilinx has implemented the terminated variation for this standard. This standard requires a differential amplifier input buffer and a Open Drain output buffer.

### GTL+ — Gunning Transceiver Logic Plus

The Gunning Transceiver Logic Plus, or GTL+ standard is a high-speed bus standard (JESD8.3) first used by the Pentium Pro processor.

### HSTL — High-Speed Transceiver Logic

The High-Speed Transceiver Logic, or HSTL standard is a general purpose high-speed, 1.5 V bus standard sponsored by IBM (EIA/JESD 8-6). This standard has four variations or classes. SelectI/O devices support Class I, III, and IV. This

standard requires a Differential Amplifier input buffer and a Push-Pull output buffer.

### **SSTL3 — Stub Series Terminated Logic for 3.3V**

The Stub Series Terminated Logic for 3.3 V, or SSTL3 standard is a general purpose 3.3 V memory bus standard also sponsored by Hitachi and IBM (JESD8-8). This standard has two classes, I and II. Select/O devices support both classes for the SSTL3 standard. This standard requires a Differential Amplifier input buffer and an Push-Pull output buffer.

### **SSTL2 — Stub Series Terminated Logic for 2.5V**

The Stub Series Terminated Logic for 2.5 V, or SSTL2 standard is a general purpose 2.5 V memory bus standard sponsored by Hitachi and IBM (JESD8-9). This standard has two classes, I and II. Select/O devices support both classes for the SSTL2 standard. This standard requires a Differential Amplifier input buffer and an Push-Pull output buffer.

### **CTT — Center Tap Terminated**

The Center Tap Terminated, or CTT standard is a 3.3 V memory bus standard sponsored by Fujitsu (JESD8-4). This standard requires a Differential Amplifier input buffer and a Push-Pull output buffer.

### **AGP-2X — Advanced Graphics Port**

The Intel AGP standard is a 3.3 V Advanced Graphics Port-2X bus standard used with the Pentium II processor for graphics applications. This standard requires a Push-Pull output buffer and a Differential Amplifier input buffer.

### **LVDS — Low Voltage Differential Signal**

LVDS is a differential I/O standard. It requires that one data bit is carried through two signal lines. As with all differential signaling standards, LVDS has an inherent noise immunity over single-ended I/O standards. The voltage swing between two signal lines is approximately 350 mV. The use of a reference voltage ( $V_{REF}$ ) or a board termination voltage ( $V_{TT}$ ) is not required. LVDS requires the use of two pins per input or output. LVDS requires external resistor termination.

### **BLVDS — Bus LVDS**

This standard allows for bidirectional LVDS communication between two or more devices. The external resistor termination is different than the one for standard LVDS.

### **LVPECL — Low Voltage Positive Emitter Coupled Logic**

LVPECL is another differential I/O standard. It requires two signal lines for transmitting one data bit. This standard specifies two pins per input or output. The voltage swing between these two signal lines is approximately 850 mV. The use of a reference voltage ( $V_{REF}$ ) or a board termination voltage ( $V_{TT}$ ) is not required. The LVPECL standard requires external resistor termination.

## **Library Symbols**

The Xilinx library includes an extensive list of symbols designed to provide support for the variety of Select/O features. Most of these symbols represent variations of the five generic Select/O symbols.

- IBUF (input buffer)
- IBUFG (global clock input buffer)
- OBUF (output buffer)
- OBUFT (3-state output buffer)
- IOBUF (input/output buffer)

### **IBUF**

Signals used as inputs to the Virtex-E device must source an input buffer (IBUF) via an external input port. The generic Virtex-E IBUF symbol appears in [Figure 37](#). The extension to the base name defines which I/O standard the IBUF uses. The assumed standard is LVTTTL when the generic IBUF has no specified extension.

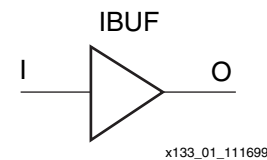

Figure 37: Input Buffer (IBUF) Symbols

The following list details the variations of the IBUF symbol:

- IBUF
- IBUF\_LVCMOS2
- IBUF\_PCI33\_3
- IBUF\_PCI66\_3
- IBUF\_GTL
- IBUF\_GTLP
- IBUF\_HSTL\_I
- IBUF\_HSTL\_III
- IBUF\_HSTL\_IV
- IBUF\_SSTL3\_I
- IBUF\_SSTL3\_II
- IBUF\_SSTL2\_I
- IBUF\_SSTL2\_II
- IBUF\_CTT
- IBUF\_AGP
- IBUF\_LVCMOS18
- IBUF\_LVDS
- IBUF\_LVPECL

When the IBUF symbol supports an I/O standard that requires a  $V_{REF}$ , the IBUF automatically configures as a differential amplifier input buffer. The  $V_{REF}$  voltage must be supplied on the  $V_{REF}$  pins. In the case of LVDS, LVPECL, and BLVDS,  $V_{REF}$  is not required.



The voltage reference signal is “banked” within the Virtex-E device on a half-edge basis such that for all packages there are eight independent  $V_{REF}$  banks internally. See [Figure 38](#) for a representation of the Virtex-E I/O banks. Within each bank approximately one of every six I/O pins is automatically configured as a  $V_{REF}$  input. After placing a differential amplifier input signal within a given  $V_{REF}$  bank, the same external source must drive all I/O pins configured as a  $V_{REF}$  input.

IBUF placement restrictions require that any differential amplifier input signals within a bank be of the same standard. How to specify a specific location for the IBUF via the LOC property is described below. [Table 19](#) summarizes the Virtex-E input standards compatibility requirements.

An optional delay element is associated with each IBUF. When the IBUF drives a flip-flop within the IOB, the delay element by default activates to ensure a zero hold-time requirement. The NODELAY=TRUE property overrides this default.

When the IBUF does not drive a flip-flop within the IOB, the delay element de-activates by default to provide higher performance. To delay the input signal, activate the delay element with the DELAY=TRUE property.

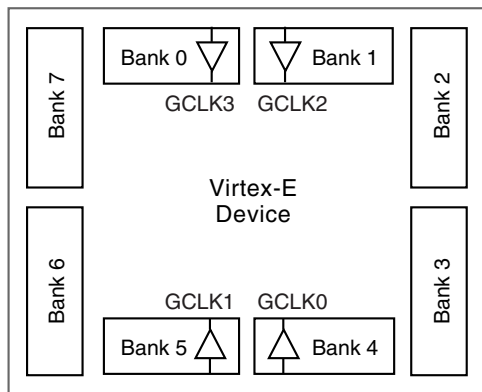

ds022\_42\_012100

Figure 38: Virtex-E I/O Banks

Table 19: Xilinx Input Standards Compatibility Requirements

Rule 1	Standards with the same input $V_{CCO}$ , output $V_{CCO}$ , and $V_{REF}$ can be placed within the same bank.
--------	--

**IBUFG**

Signals used as high fanout clock inputs to the Virtex-E device should drive a global clock input buffer (IBUFG) via an external input port in order to take advantage of one of the four dedicated global clock distribution networks. The output of the IBUFG symbol can only drive a CLKDLL,

CLKDLLHF, or a BUFG symbol. The generic Virtex-E IBUFG symbol appears in [Figure 39](#).

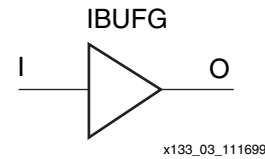

Figure 39: Virtex-E Global Clock Input Buffer (IBUFG) Symbol

The extension to the base name determines which I/O standard is used by the IBUFG. With no extension specified for the generic IBUFG symbol, the assumed standard is LVTTTL.

The following list details variations of the IBUFG symbol.

- IBUFG
- IBUFG\_LVCMOS2
- IBUFG\_PCI33\_3
- IBUFG\_PCI66\_3
- IBUFG\_GTL
- IBUFG\_GTLP
- IBUFG\_HSTL\_I
- IBUFG\_HSTL\_III
- IBUFG\_HSTL\_IV
- IBUFG\_SSTL3\_I
- IBUFG\_SSTL3\_II
- IBUFG\_SSTL2\_I
- IBUFG\_SSTL2\_II
- IBUFG\_CTT
- IBUFG\_AGP
- IBUFG\_LVCMOS18
- IBUFG\_LVDS
- IBUFG\_LVPECL

When the IBUFG symbol supports an I/O standard that requires a differential amplifier input, the IBUFG automatically configures as a differential amplifier input buffer. The low-voltage I/O standards with a differential amplifier input require an external reference voltage input  $V_{REF}$

The voltage reference signal is “banked” within the Virtex-E device on a half-edge basis such that for all packages there are eight independent  $V_{REF}$  banks internally. See [Figure 38](#) for a representation of the Virtex-E I/O banks. Within each bank approximately one of every six I/O pins is automatically configured as a  $V_{REF}$  input. After placing a differential amplifier input signal within a given  $V_{REF}$  bank, the same external source must drive all I/O pins configured as a  $V_{REF}$  input.

IBUFG placement restrictions require any differential amplifier input signals within a bank be of the same standard. The LOC property can specify a location for the IBUFG.

As an added convenience, the BUFGP can be used to instantiate a high fanout clock input. The BUFGP symbol represents a combination of the LVTTTL IBUFG and BUFG symbols, such that the output of the BUFGP can connect directly to the clock pins throughout the design.

Unlike previous architectures, the Virtex-E BUFGP symbol can only be placed in a global clock pad location. The LOC property can specify a location for the BUFGP.

### OBUF

An OBUF must drive outputs through an external output port. The generic output buffer (OBUF) symbol appears in [Figure 40](#).

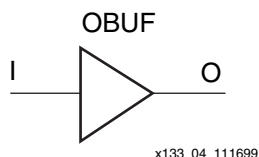

Figure 40: Virtex-E Output Buffer (OBUF) Symbol

The extension to the base name defines which I/O standard the OBUF uses. With no extension specified for the generic OBUF symbol, the assumed standard is slew rate limited LVTTTL with 12 mA drive strength.

The LVTTTL OBUF additionally can support one of two slew rate modes to minimize bus transients. By default, the slew rate for each output buffer is reduced to minimize power bus transients when switching non-critical signals.

LVTTTL output buffers have selectable drive strengths.

The format for LVTTTL OBUF symbol names is as follows.

OBUF\_<slew\_rate>\_<drive\_strength>

<slew\_rate> is either F (Fast), or S (Slow) and <drive\_strength> is specified in milliamps (2, 4, 6, 8, 12, 16, or 24).

The following list details variations of the OBUF symbol.

- OBUF
- OBUF\_S\_2
- OBUF\_S\_4
- OBUF\_S\_6
- OBUF\_S\_8
- OBUF\_S\_12
- OBUF\_S\_16
- OBUF\_S\_24
- OBUF\_F\_2
- OBUF\_F\_4
- OBUF\_F\_6
- OBUF\_F\_8
- OBUF\_F\_12
- OBUF\_F\_16

- OBUF\_F\_24
- OBUF\_LVCMOS2
- OBUF\_PCI33\_3
- OBUF\_PCI66\_3
- OBUF\_GTL
- OBUF\_GTLP
- OBUF\_HSTL\_I
- OBUF\_HSTL\_III
- OBUF\_HSTL\_IV
- OBUF\_SSTL3\_I
- OBUF\_SSTL3\_II
- OBUF\_SSTL2\_I
- OBUF\_SSTL2\_II
- OBUF\_CTT
- OBUF\_AGP
- OBUF\_LVCMOS18
- OBUF\_LVDS
- OBUF\_LVPECL

The Virtex-E series supports eight banks for the HQ and PQ packages. The CS packages support four  $V_{CCO}$  banks.

OBUF placement restrictions require that within a given  $V_{CCO}$  bank each OBUF share the same output source drive voltage. Input buffers of any type and output buffers that do not require  $V_{CCO}$  can be placed within any  $V_{CCO}$  bank.

[Table 20](#) summarizes the Virtex-E output compatibility requirements. The LOC property can specify a location for the OBUF.

Table 20: Output Standards Compatibility Requirements

Rule 1	Only outputs with standards that share compatible $V_{CCO}$ can be used within the same bank.
Rule 2	There are no placement restrictions for outputs with standards that do not require a $V_{CCO}$ .
$V_{CCO}$	Compatible Standards
3.3	LVTTTL, SSTL3_I, SSTL3_II, CTT, AGP, GTL, GTL+, PCI33_3, PCI66_3
2.5	SSTL2_I, SSTL2_II, LVCMOS2, GTL, GTL+
1.5	HSTL_I, HSTL_III, HSTL_IV, GTL, GTL+

### OBUFT

The generic 3-state output buffer OBUFT, shown in [Figure 41](#), typically implements 3-state outputs or bidirectional I/O.

The extension to the base name defines which I/O standard OBUFT uses. With no extension specified for the generic OBUFT symbol, the assumed standard is slew rate limited LVTTTL with 12 mA drive strength.

The LVTTTL OBUFT additionally can support one of two slew rate modes to minimize bus transients. By default, the slew rate for each output buffer is reduced to minimize power bus transients when switching non-critical signals.

LVTTTL 3-state output buffers have selectable drive strengths.

The format for LVTTTL OBUFT symbol names is as follows.

OBUFT\_<slew\_rate>\_<drive\_strength>

<slew\_rate> can be either F (Fast), or S (Slow) and <drive\_strength> is specified in milliamps (2, 4, 6, 8, 12, 16, or 24).

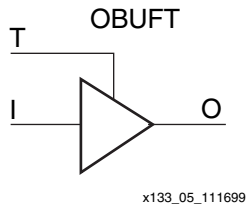

**Figure 41: 3-State Output Buffer Symbol (OBUFT)**

The following list details variations of the OBUFT symbol.

- OBUFT
- OBUFT\_S\_2
- OBUFT\_S\_4
- OBUFT\_S\_6
- OBUFT\_S\_8
- OBUFT\_S\_12
- OBUFT\_S\_16
- OBUFT\_S\_24
- OBUFT\_F\_2
- OBUFT\_F\_4
- OBUFT\_F\_6
- OBUFT\_F\_8
- OBUFT\_F\_12
- OBUFT\_F\_16
- OBUFT\_F\_24
- OBUFT\_LVCMOS2
- OBUFT\_PCI33\_3
- OBUFT\_PCI66\_3
- OBUFT\_GTL
- OBUFT\_GTLP
- OBUFT\_HSTL\_I
- OBUFT\_HSTL\_III
- OBUFT\_HSTL\_IV
- OBUFT\_SSTL3\_I
- OBUFT\_SSTL3\_II
- OBUFT\_SSTL2\_I
- OBUFT\_SSTL2\_II
- OBUFT\_CTT
- OBUFT\_AGP
- OBUFT\_LVCMOS18
- OBUFT\_LVDS
- OBUFT\_LVPECL

The Virtex-E series supports eight banks for the HQ and PQ packages. The CS package supports four  $V_{CCO}$  banks.

The SelectI/O OBUFT placement restrictions require that within a given  $V_{CCO}$  bank each OBUFT share the same output source drive voltage. Input buffers of any type and output buffers that do not require  $V_{CCO}$  can be placed within the same  $V_{CCO}$  bank.

The LOC property can specify a location for the OBUFT.

3-state output buffers and bidirectional buffers can have either a weak pull-up resistor, a weak pull-down resistor, or a weak “keeper” circuit. Control this feature by adding the appropriate symbol to the output net of the OBUFT (PULLUP, PULLDOWN, or KEEPER).

The weak “keeper” circuit requires the input buffer within the IOB to sample the I/O signal. So, OBUFTs programmed for an I/O standard that requires a  $V_{REF}$  have automatic placement of a  $V_{REF}$  in the bank with an OBUFT configured with a weak “keeper” circuit. This restriction does not affect most circuit design as applications using an OBUFT configured with a weak “keeper” typically implement a bidirectional I/O. In this case the IBUF (and the corresponding  $V_{REF}$ ) are explicitly placed.

The LOC property can specify a location for the OBUFT.

### **IOBUF**

Use the IOBUF symbol for bidirectional signals that require both an input buffer and a 3-state output buffer with an active high 3-state pin. The generic input/output buffer IOBUF appears in [Figure 42](#).

The extension to the base name defines which I/O standard the IOBUF uses. With no extension specified for the generic IOBUF symbol, the assumed standard is LVTTTL input buffer and slew rate limited LVTTTL with 12 mA drive strength for the output buffer.

The LVTTTL IOBUF additionally can support one of two slew rate modes to minimize bus transients. By default, the slew rate for each output buffer is reduced to minimize power bus transients when switching non-critical signals.

LVTTTL bidirectional buffers have selectable output drive strengths.

The format for LVTTTL IOBUF symbol names is as follows.

IOBUF\_<slew\_rate>\_<drive\_strength>

<slew\_rate> can be either F (Fast), or S (Slow) and <drive\_strength> is specified in milliamps (2, 4, 6, 8, 12, 16, or 24).

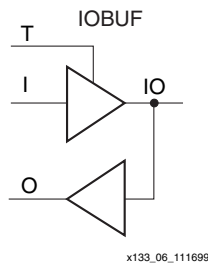

Figure 42: Input/Output Buffer Symbol (IOBUF)

The following list details variations of the IOBUF symbol.

- IOBUF
- IOBUF\_S\_2
- IOBUF\_S\_4
- IOBUF\_S\_6
- IOBUF\_S\_8
- IOBUF\_S\_12
- IOBUF\_S\_16
- IOBUF\_S\_24
- IOBUF\_F\_2
- IOBUF\_F\_4
- IOBUF\_F\_6
- IOBUF\_F\_8
- IOBUF\_F\_12
- IOBUF\_F\_16
- IOBUF\_F\_24
- IOBUF\_LVCMOS2
- IOBUF\_PCI33\_3
- IOBUF\_PCI66\_3
- IOBUF\_GTL
- IOBUF\_GTLP
- IOBUF\_HSTL\_I
- IOBUF\_HSTL\_III
- IOBUF\_HSTL\_IV
- IOBUF\_SSTL3\_I
- IOBUF\_SSTL3\_II
- IOBUF\_SSTL2\_I
- IOBUF\_SSTL2\_II
- IOBUF\_CTT
- IOBUF\_AGP
- IOBUF\_LVCMOS18
- IOBUF\_LVDS
- IOBUF\_LVPECL

When the IOBUF symbol used supports an I/O standard that requires a differential amplifier input, the IOBUF automatically configures with a differential amplifier input buffer. The low-voltage I/O standards with a differential amplifier input require an external reference voltage input  $V_{REF}$

The voltage reference signal is “banked” within the Virtex-E device on a half-edge basis such that for all packages there are eight independent  $V_{REF}$  banks internally. See [Figure 38 on page 33](#) for a representation of the Virtex-E I/O banks. Within each bank approximately one of every six I/O pins is automatically configured as a  $V_{REF}$  input. After placing a differential amplifier input signal within a given  $V_{REF}$  bank, the same external source must drive all I/O pins configured as a  $V_{REF}$  input.

IOBUF placement restrictions require any differential amplifier input signals within a bank be of the same standard.

The Virtex-E series supports eight banks for the HQ and PQ packages. The CS package supports four  $V_{CCO}$  banks.

Additional restrictions on the Virtex-E SelectI/O IOBUF placement require that within a given  $V_{CCO}$  bank each IOBUF must share the same output source drive voltage. Input buffers of any type and output buffers that do not require  $V_{CCO}$  can be placed within the same  $V_{CCO}$  bank. The LOC property can specify a location for the IOBUF.

An optional delay element is associated with the input path in each IOBUF. When the IOBUF drives an input flip-flop within the IOB, the delay element activates by default to ensure a zero hold-time requirement. Override this default with the NODELAY=TRUE property.

In the case when the IOBUF does not drive an input flip-flop within the IOB, the delay element de-activates by default to provide higher performance. To delay the input signal, activate the delay element with the DELAY=TRUE property.

3-state output buffers and bidirectional buffers can have either a weak pull-up resistor, a weak pull-down resistor, or a weak “keeper” circuit. Control this feature by adding the appropriate symbol to the output net of the IOBUF (PULLUP, PULLDOWN, or KEEPER).

## SelectI/O Properties

Access to some of the SelectI/O features (for example, location constraints, input delay, output drive strength, and slew rate) is available through properties associated with these features.

## Input Delay Properties

An optional delay element is associated with each IOBUF. When the IOBUF drives a flip-flop within the IOB, the delay element activates by default to ensure a zero hold-time requirement. Use the NODELAY=TRUE property to override this default.

In the case when the IOBUF does not drive a flip-flop within the IOB, the delay element by default de-activates to provide higher performance. To delay the input signal, activate the delay element with the DELAY=TRUE property.

### IOB Flip-Flop/Latch Property

The Virtex-E series I/O block (IOB) includes an optional register on the input path, an optional register on the output path, and an optional register on the 3-state control pin. The design implementation software automatically takes advantage of these registers when the following option for the Map program is specified.

```
map -pr b <filename>
```

Alternatively, the IOB = TRUE property can be placed on a register to force the mapper to place the register in an IOB.

### Location Constraints

Specify the location of each Select/I/O symbol with the location constraint LOC attached to the Select/I/O symbol. The external port identifier indicates the value of the location constrain. The format of the port identifier depends on the package chosen for the specific design.

The LOC properties use the following form.

```
LOC=A42
```

```
LOC=P37
```

### Output Slew Rate Property

As mentioned above, a variety of symbol names provide the option of choosing the desired slew rate for the output buffers. In the case of the LVTTTL output buffers (OBUF, OBUFT, and IOBUF), slew rate control can be alternatively programmed with the SLEW= property. By default, the slew rate for each output buffer is reduced to minimize power bus transients when switching non-critical signals. The SLEW= property has one of the two following values.

```
SLEW=SLOW
```

```
SLEW=FAST
```

### Output Drive Strength Property

The desired output drive strength can be additionally specified by choosing the appropriate library symbol. The Xilinx library also provides an alternative method for specifying this feature. For the LVTTTL output buffers (OBUF, OBUFT, and IOBUF), the desired drive strength can be specified with the DRIVE= property. This property could have one of the following seven values.

```
DRIVE=2
```

```
DRIVE=4
```

```
DRIVE=6
```

```
DRIVE=8
```

```
DRIVE=12 (Default)
```

```
DRIVE=16
```

```
DRIVE=24
```

## Design Considerations

### Reference Voltage ( $V_{REF}$ ) Pins

Low-voltage I/O standards with a differential amplifier input buffer require an input reference voltage ( $V_{REF}$ ). Provide the  $V_{REF}$  as an external signal to the device.

The voltage reference signal is “banked” within the device on a half-edge basis such that for all packages there are eight independent  $V_{REF}$  banks internally. See [Figure 38](#) for a representation of the Virtex-E I/O banks. Within each bank approximately one of every six I/O pins is automatically configured as a  $V_{REF}$  input. After placing a differential amplifier input signal within a given  $V_{REF}$  bank, the same external source must drive all I/O pins configured as a  $V_{REF}$  input.

Within each  $V_{REF}$  bank, any input buffers that require a  $V_{REF}$  signal must be of the same type. Output buffers of any type and input buffers can be placed without requiring a reference voltage within the same  $V_{REF}$  bank.

### Output Drive Source Voltage ( $V_{CCO}$ ) Pins

Many of the low voltage I/O standards supported by Select/I/O devices require a different output drive source voltage ( $V_{CCO}$ ). As a result each device can often have to support multiple output drive source voltages.

The Virtex-E series supports eight banks for the HQ and PQ packages. The CS package supports four  $V_{CCO}$  banks.

Output buffers within a given  $V_{CCO}$  bank must share the same output drive source voltage. Input buffers for LVTTTL, LVCMOS2, LVCMOS18, PCI33\_3, and PCI 66\_3 use the  $V_{CCO}$  voltage for Input  $V_{CCO}$  voltage.

### Transmission Line Effects

The delay of an electrical signal along a wire is dominated by the rise and fall times when the signal travels a short distance. Transmission line delays vary with inductance and capacitance, but a well-designed board can experience delays of approximately 180 ps per inch.

Transmission line effects, or reflections, typically start at 1.5" for fast (1.5 ns) rise and fall times. Poor (or non-existent) termination or changes in the transmission line impedance cause these reflections and can cause additional delay in longer traces. As system speeds continue to increase, the effect of I/O delays can become a limiting factor and therefore transmission line termination becomes increasingly more important.

### Termination Techniques

A variety of termination techniques reduce the impact of transmission line effects.

The following are output termination techniques:

- None
- Series
- Parallel (Shunt)
- Series and Parallel (Series-Shunt)



Input termination techniques include the following:

- None
- Parallel (Shunt)

These termination techniques can be applied in any combination. A generic example of each combination of termination methods appears in **Figure 43**.

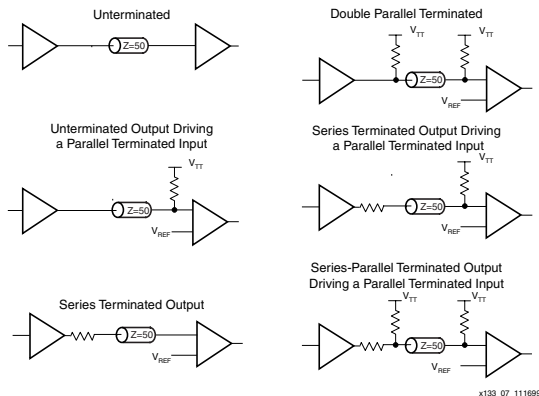

**Figure 43: Overview of Standard Input and Output Termination Methods**

### Simultaneous Switching Guidelines

Ground bounce can occur with high-speed digital ICs when multiple outputs change states simultaneously, causing undesired transient behavior on an output, or in the internal logic. This problem is also referred to as the Simultaneous Switching Output (SSO) problem.

Ground bounce is primarily due to current changes in the combined inductance of ground pins, bond wires, and ground metallization. The IC internal ground level deviates from the external system ground level for a short duration (a few nanoseconds) after multiple outputs change state simultaneously.

Ground bounce affects stable Low outputs and all inputs because they interpret the incoming signal by comparing it to the internal ground. If the ground bounce amplitude exceeds the actual instantaneous noise margin, then a non-changing input can be interpreted as a short pulse with a polarity opposite to the ground bounce.

**Table 21** provides the guidelines for the maximum number of simultaneously switching outputs allowed per output power/ground pair to avoid the effects of ground bounce. Refer to **Table 22** for the number of effective output power/ground pairs for each Virtex-E device and package combination.

**Table 21: Guidelines for Maximum Number of Simultaneously Switching Outputs per Power/Ground Pair**

Standard	Package
	BGA, FGA
LVTTL Slow Slew Rate, 2 mA drive	68
LVTTL Slow Slew Rate, 4 mA drive	41
LVTTL Slow Slew Rate, 6 mA drive	29
LVTTL Slow Slew Rate, 8 mA drive	22
LVTTL Slow Slew Rate, 12 mA drive	17
LVTTL Slow Slew Rate, 16 mA drive	14
LVTTL Slow Slew Rate, 24 mA drive	9
LVTTL Fast Slew Rate, 2 mA drive	40
LVTTL Fast Slew Rate, 4 mA drive	24
LVTTL Fast Slew Rate, 6 mA drive	17
LVTTL Fast Slew Rate, 8 mA drive	13
LVTTL Fast Slew Rate, 12 mA drive	10
LVTTL Fast Slew Rate, 16 mA drive	8
LVTTL Fast Slew Rate, 24 mA drive	5
LVC MOS2	10
PCI	8
GTL	4
GTL+	4
HSTL Class I	18
HSTL Class III	9
HSTL Class IV	5
SSTL2 Class I	15
SSTL2 Class II	10
SSTL3 Class I	11
SSTL3 Class II	7
CTT	14
AGP	9

Note: This analysis assumes a 35 pF load for each output.

**Table 22: Virtex-E Extended Memory Family Equivalent Power/Ground Pairs**

Pkg/Part	XCV405E	XCV812E
BG560		56
FG676	56	
FG900		



## Application Examples

Creating a design with the SelectI/O features requires the instantiation of the desired library symbol within the design code. At the board level, designers need to know the termination techniques required for each I/O standard.

This section describes some common application examples illustrating the termination techniques recommended by each of the standards supported by the SelectI/O features.

### Termination Examples

Circuit examples involving typical termination techniques for each of the SelectI/O standards follow. For a full range of accepted values for the DC voltage specifications for each standard, refer to the table associated with each figure.

The resistors used in each termination technique example and the transmission lines depicted represent board level components and are not meant to represent components on the device.

#### GTL

A sample circuit illustrating a valid termination technique for GTL is shown in Figure 44. Table 23 lists DC voltage specifications.

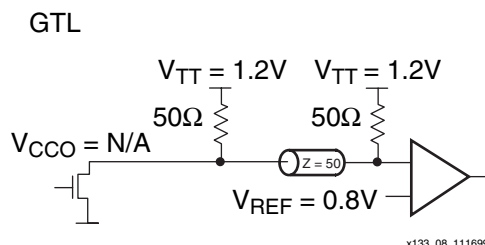

Figure 44: Terminated GTL

Table 23: GTL Voltage Specifications

Parameter	Min	Typ	Max
$V_{CCO}$	-	N/A	-
$V_{REF} = N \times V_{TT}^1$	0.74	0.8	0.86
$V_{TT}$	1.14	1.2	1.26
$V_{IH} = V_{REF} + 0.05$	0.79	0.85	-
$V_{IL} = V_{REF} - 0.05$	-	0.75	0.81
$V_{OH}$	-	-	-
$V_{OL}$	-	0.2	0.4
$I_{OH}$ at $V_{OH}$ (mA)	-	-	-
$I_{OL}$ at $V_{OL}$ (mA) at 0.4V	32	-	-
$I_{OL}$ at $V_{OL}$ (mA) at 0.2V	-	-	40

Note: N must be greater than or equal to 0.653 and less than or equal to 0.68.

#### GTL+

A sample circuit illustrating a valid termination technique for GTL+ appears in Figure 45. DC voltage specifications appear in Table 24.

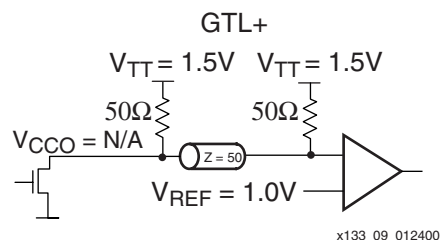

Figure 45: Terminated GTL+

Table 24: GTL+ Voltage Specifications

Parameter	Min	Typ	Max
$V_{CCO}$	-	-	-
$V_{REF} = N \times V_{TT}^1$	0.88	1.0	1.12
$V_{TT}$	1.35	1.5	1.65
$V_{IH} = V_{REF} + 0.1$	0.98	1.1	-
$V_{IL} = V_{REF} - 0.1$	-	0.9	1.02
$V_{OH}$	-	-	-
$V_{OL}$	0.3	0.45	0.6
$I_{OH}$ at $V_{OH}$ (mA)	-	-	-
$I_{OL}$ at $V_{OL}$ (mA) at 0.6V	36	-	-
$I_{OL}$ at $V_{OL}$ (mA) at 0.3V	-	-	48

Note: N must be greater than or equal to 0.653 and less than or equal to 0.68.

## HSTL

A sample circuit illustrating a valid termination technique for HSTL\_I appears in Figure 46. A sample circuit illustrating a valid termination technique for HSTL\_III appears in Figure 47.

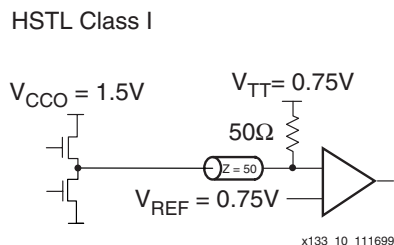

Figure 46: Terminated HSTL Class I

Table 25: HSTL Class I Voltage Specification

Parameter	Min	Typ	Max
$V_{CCO}$	1.40	1.50	1.60
$V_{REF}$	0.68	0.75	0.90
$V_{TT}$	-	$V_{CCO} \times 0.5$	-
$V_{IH}$	$V_{REF} + 0.1$	-	-
$V_{IL}$	-	-	$V_{REF} - 0.1$
$V_{OH}$	$V_{CCO} - 0.4$	-	-
$V_{OL}$	-	-	0.4
$I_{OH}$ at $V_{OH}$ (mA)	-8	-	-
$I_{OL}$ at $V_{OL}$ (mA)	8	-	-

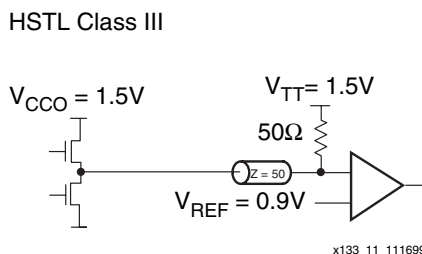

Figure 47: Terminated HSTL Class III

Table 26: HSTL Class III Voltage Specification

Parameter	Min	Typ	Max
$V_{CCO}$	1.40	1.50	1.60
$V_{REF}^{(1)}$	-	0.90	-
$V_{TT}$	-	$V_{CCO}$	-
$V_{IH}$	$V_{REF} + 0.1$	-	-
$V_{IL}$	-	-	$V_{REF} - 0.1$
$V_{OH}$	$V_{CCO} - 0.4$	-	-
$V_{OL}$	-	-	0.4
$I_{OH}$ at $V_{OH}$ (mA)	-8	-	-
$I_{OL}$ at $V_{OL}$ (mA)	24	-	-

Note: Per EIA/JESD8-6, "The value of  $V_{REF}$  is to be selected by the user to provide optimum noise margin in the use conditions specified by the user."

A sample circuit illustrating a valid termination technique for HSTL\_IV appears in Figure 48.

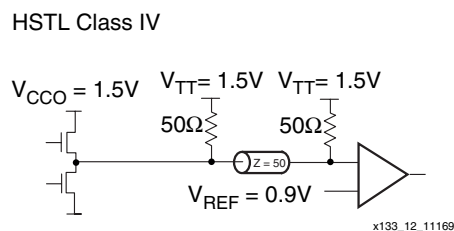

Figure 48: Terminated HSTL Class IV

Table 27: HSTL Class IV Voltage Specification

Parameter	Min	Typ	Max
$V_{CCO}$	1.40	1.50	1.60
$V_{REF}$	-	0.90	-
$V_{TT}$	-	$V_{CCO}$	-
$V_{IH}$	$V_{REF} + 0.1$	-	-
$V_{IL}$	-	-	$V_{REF} - 0.1$
$V_{OH}$	$V_{CCO} - 0.4$	-	-
$V_{OL}$	-	-	0.4
$I_{OH}$ at $V_{OH}$ (mA)	-8	-	-
$I_{OL}$ at $V_{OL}$ (mA)	48	-	-

Note: Per EIA/JESD8-6, "The value of  $V_{REF}$  is to be selected by the user to provide optimum noise margin in the use conditions specified by the user."

**SSTL3\_I**

A sample circuit illustrating a valid termination technique for SSTL3\_I appears in Figure 49. DC voltage specifications appear in Table 28.

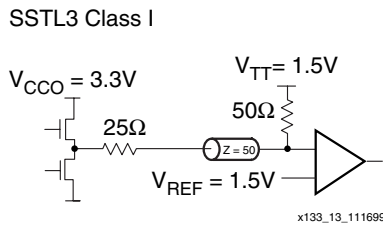

Figure 49: Terminated SSTL3 Class I

Table 28: SSTL3\_I Voltage Specifications

Parameter	Min	Typ	Max
$V_{CCO}$	3.0	3.3	3.6
$V_{REF} = 0.45 \times V_{CCO}$	1.3	1.5	1.7
$V_{TT} = V_{REF}$	1.3	1.5	1.7
$V_{IH} = V_{REF} + 0.2$	1.5	1.7	3.9 <sup>(1)</sup>
$V_{IL} = V_{REF} - 0.2$	-0.3 <sup>(2)</sup>	1.3	1.5
$V_{OH} = V_{REF} + 0.6$	1.9	-	-
$V_{OL} = V_{REF} - 0.6$	-	-	1.1
$I_{OH}$ at $V_{OH}$ (mA)	-8	-	-
$I_{OL}$ at $V_{OL}$ (mA)	8	-	-

**Notes:**

- $V_{IH}$  maximum is  $V_{CCO} + 0.3$
- $V_{IL}$  minimum does not conform to the formula

**SSTL3\_II**

A sample circuit illustrating a valid termination technique for SSTL3\_II appears in Figure 50. DC voltage specifications appear in Table 29.

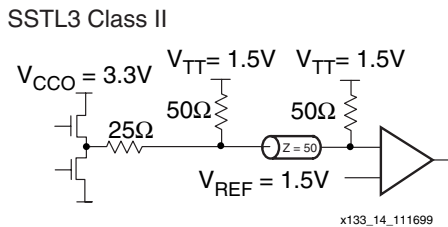

Figure 50: Terminated SSTL3 Class II

Table 29: SSTL3\_II Voltage Specifications

Parameter	Min	Typ	Max
$V_{CCO}$	3.0	3.3	3.6
$V_{REF} = 0.45 \times V_{CCO}$	1.3	1.5	1.7
$V_{TT} = V_{REF}$	1.3	1.5	1.7
$V_{IH} = V_{REF} + 0.2$	1.5	1.7	3.9 <sup>(1)</sup>
$V_{IL} = V_{REF} - 0.2$	-0.3 <sup>(2)</sup>	1.3	1.5
$V_{OH} = V_{REF} + 0.8$	2.1	-	-
$V_{OL} = V_{REF} - 0.8$	-	-	0.9
$I_{OH}$ at $V_{OH}$ (mA)	-16	-	-
$I_{OL}$ at $V_{OL}$ (mA)	16	-	-

**Notes:**

- $V_{IH}$  maximum is  $V_{CCO} + 0.3$
- $V_{IL}$  minimum does not conform to the formula

**SSTL2\_I**

A sample circuit illustrating a valid termination technique for SSTL2\_I appears in Figure 51. DC voltage specifications appear in Table 30.

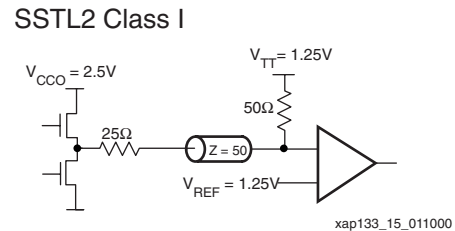

Figure 51: Terminated SSTL2 Class I

Table 30: SSTL2\_I Voltage Specifications

Parameter	Min	Typ	Max
$V_{CCO}$	2.3	2.5	2.7
$V_{REF} = 0.5 \times V_{CCO}$	1.15	1.25	1.35
$V_{TT} = V_{REF} + N(1)$	1.11	1.25	1.39
$V_{IH} = V_{REF} + 0.18$	1.33	1.43	3.0 <sup>(2)</sup>
$V_{IL} = V_{REF} - 0.18$	-0.3 <sup>(3)</sup>	1.07	1.17
$V_{OH} = V_{REF} + 0.61$	1.76	-	-
$V_{OL} = V_{REF} - 0.61$	-	-	0.74
$I_{OH}$ at $V_{OH}$ (mA)	-7.6	-	-
$I_{OL}$ at $V_{OL}$ (mA)	7.6	-	-

**Notes:**

- N must be greater than or equal to -0.04 and less than or equal to 0.04.
- $V_{IH}$  maximum is  $V_{CCO} + 0.3$ .
- $V_{IL}$  minimum does not conform to the formula.

**SSTL2\_II**

A sample circuit illustrating a valid termination technique for SSTL2\_II appears in Figure 52. DC voltage specifications appear in Table 31.

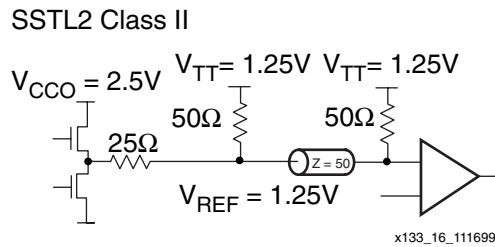

Figure 52: Terminated SSTL2 Class II

Table 31: SSTL2\_II Voltage Specifications

Parameter	Min	Typ	Max
V <sub>CCO</sub>	2.3	2.5	2.7
V <sub>REF</sub> = 0.5 × V <sub>CCO</sub>	1.15	1.25	1.35
V <sub>TT</sub> = V <sub>REF</sub> + N <sup>(1)</sup>	1.11	1.25	1.39
V <sub>IH</sub> = V <sub>REF</sub> + 0.18	1.33	1.43	3.0 <sup>(2)</sup>
V <sub>IL</sub> = V <sub>REF</sub> - 0.18	-0.3 <sup>(3)</sup>	1.07	1.17
V <sub>OH</sub> = V <sub>REF</sub> + 0.8	1.95	-	-
V <sub>OL</sub> = V <sub>REF</sub> - 0.8	-	-	0.55
I <sub>OH</sub> at V <sub>OH</sub> (mA)	-15.2	-	-
I <sub>OL</sub> at V <sub>OL</sub> (mA)	15.2	-	-

**Notes:**

- N must be greater than or equal to -0.04 and less than or equal to 0.04.
- V<sub>IH</sub> maximum is V<sub>CCO</sub> + 0.3.
- V<sub>IL</sub> minimum does not conform to the formula.

**CTT**

A sample circuit illustrating a valid termination technique for CTT appear in Figure 53. DC voltage specifications appear in Table 32.

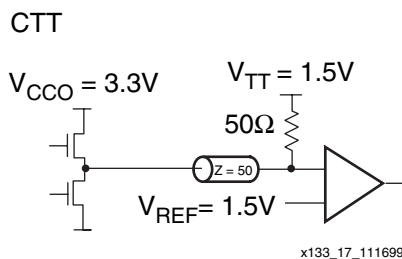

Figure 53: Terminated CTT

Table 32: CTT Voltage Specifications

Parameter	Min	Typ	Max
V <sub>CCO</sub>	2.05 <sup>(1)</sup>	3.3	3.6
V <sub>REF</sub>	1.35	1.5	1.65
V <sub>TT</sub>	1.35	1.5	1.65
V <sub>IH</sub> = V <sub>REF</sub> + 0.2	1.55	1.7	-
V <sub>IL</sub> = V <sub>REF</sub> - 0.2	-	1.3	1.45
V <sub>OH</sub> = V <sub>REF</sub> + 0.4	1.75	1.9	-
V <sub>OL</sub> = V <sub>REF</sub> - 0.4	-	1.1	1.25
I <sub>OH</sub> at V <sub>OH</sub> (mA)	-8	-	-
I <sub>OL</sub> at V <sub>OL</sub> (mA)	8	-	-

**Notes:**

- Timing delays are calculated based on V<sub>CCO</sub> min of 3.0V.

**PCI33\_3 & PCI66\_3**

PCI33\_3 or PCI66\_3 require no termination. DC voltage specifications appear in Table 33.

Table 33: PCI33\_3 and PCI66\_3 Voltage Specifications

Parameter	Min	Typ	Max
V <sub>CCO</sub>	3.0	3.3	3.6
V <sub>REF</sub>	-	-	-
V <sub>TT</sub>	-	-	-
V <sub>IH</sub> = 0.5 × V <sub>CCO</sub>	1.5	1.65	V <sub>CCO</sub> + 0.5
V <sub>IL</sub> = 0.3 × V <sub>CCO</sub>	-0.5	0.99	1.08
V <sub>OH</sub> = 0.9 × V <sub>CCO</sub>	2.7	-	-
V <sub>OL</sub> = 0.1 × V <sub>CCO</sub>	-	-	0.36
I <sub>OH</sub> at V <sub>OH</sub> (mA)	Note 1	-	-
I <sub>OL</sub> at V <sub>OL</sub> (mA)	Note 1	-	-

Note 1: Tested according to the relevant specification.

### LVTTL

LVTTL requires no termination. DC voltage specifications appears in [Table 34](#).

Table 34: LVTTL Voltage Specifications

Parameter	Min	Typ	Max
V <sub>CCO</sub>	3.0	3.3	3.6
V <sub>REF</sub>	-	-	-
V <sub>TT</sub>	-	-	-
V <sub>IH</sub>	2.0	-	3.6
V <sub>IL</sub>	-0.5	-	0.8
V <sub>OH</sub>	2.4	-	-
V <sub>OL</sub>	-	-	0.4
I <sub>OH</sub> at V <sub>OH</sub> (mA)	-24	-	-
I <sub>OL</sub> at V <sub>OL</sub> (mA)	24	-	-

Note: V<sub>OL</sub> and V<sub>OH</sub> for lower drive currents sample tested.

### LVC MOS2

LVC MOS2 requires no termination. DC voltage specifications appear in [Table 35](#).

Table 35: LVC MOS2 Voltage Specifications

Parameter	Min	Typ	Max
V <sub>CCO</sub>	2.3	2.5	2.7
V <sub>REF</sub>	-	-	-
V <sub>TT</sub>	-	-	-
V <sub>IH</sub>	1.7	-	3.6
V <sub>IL</sub>	-0.5	-	0.7
V <sub>OH</sub>	1.9	-	-
V <sub>OL</sub>	-	-	0.4
I <sub>OH</sub> at V <sub>OH</sub> (mA)	-12	-	-
I <sub>OL</sub> at V <sub>OL</sub> (mA)	12	-	-

### LVC MOS18

LVC MOS18 does not require termination. [Table 36](#) lists DC voltage specifications.

Table 36: LVC MOS18 Voltage Specifications

Parameter	Min	Typ	Max
V <sub>CCO</sub>	1.70	1.80	1.90
V <sub>REF</sub>	-	-	-
V <sub>TT</sub>	-	-	-
V <sub>IH</sub>	0.7 x V <sub>CCO</sub>	-	1.95
V <sub>IL</sub>	-0.5	-	0.2 x V <sub>CCO</sub>
V <sub>OH</sub>	V <sub>CCO</sub> - 0.4	-	-
V <sub>OL</sub>	-	-	0.4
I <sub>OH</sub> at V <sub>OH</sub> (mA)	-8	-	-
I <sub>OL</sub> at V <sub>OL</sub> (mA)	8	-	-

### AGP-2X

The specification for the AGP-2X standard does not document a recommended termination technique. DC voltage specifications appear in [Table 37](#).

Table 37: AGP-2X Voltage Specifications

Parameter	Min	Typ	Max
V <sub>CCO</sub>	3.0	3.3	3.6
V <sub>REF</sub> = N x V <sub>CCO</sub> <sup>(1)</sup>	1.17	1.32	1.48
V <sub>TT</sub>	-	-	-
V <sub>IH</sub> = V <sub>REF</sub> + 0.2	1.37	1.52	-
V <sub>IL</sub> = V <sub>REF</sub> - 0.2	-	1.12	1.28
V <sub>OH</sub> = 0.9 x V <sub>CCO</sub>	2.7	3.0	-
V <sub>OL</sub> = 0.1 x V <sub>CCO</sub>	-	0.33	0.36
I <sub>OH</sub> at V <sub>OH</sub> (mA)	Note 2	-	-
I <sub>OL</sub> at V <sub>OL</sub> (mA)	Note 2	-	-

#### Notes:

- N must be greater than or equal to 0.39 and less than or equal to 0.41.
- Tested according to the relevant specification.

### LVDS

Depending on whether the device is transmitting an LVDS signal or receiving an LVDS signal, there are two different circuits used for LVDS termination. A sample circuit illustrating a valid termination technique for transmitting LVDS signals appears in [Figure 54](#). A sample circuit illustrating a valid termination for receiving LVDS signals appears in [Figure 55](#). [Table 38](#) lists DC voltage specifications. Further information on the specific termination resistor packs shown can be found on [Table 40](#).

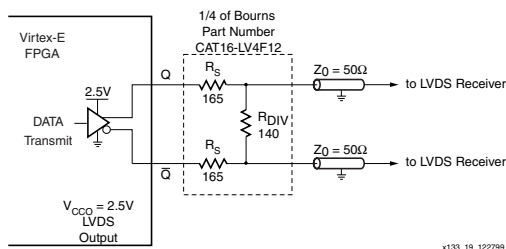

Figure 54: Transmitting LVDS Signal Circuit

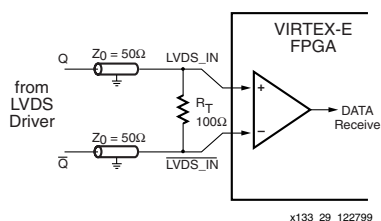

Figure 55: Receiving LVDS Signal Circuit

Table 38: LVDS Voltage Specifications

Parameter	Min	Typ	Max
V <sub>CC0</sub>	2.375	2.5	2.625
V <sub>ICM</sub> <sup>(2)</sup>	0.2	1.25	2.2
V <sub>OCM</sub> <sup>(1)</sup>	1.125	1.25	1.375
V <sub>IDIFF</sub> <sup>(1)</sup>	0.1	0.35	-
V <sub>ODIFF</sub> <sup>(1)</sup>	0.25	0.35	0.45
V <sub>OH</sub> <sup>(1)</sup>	1.25	-	-
V <sub>OL</sub> <sup>(1)</sup>	-	-	1.25

**Notes:**

1. Measured with a 100 Ω resistor across Q and  $\bar{Q}$ .
2. Measured with a differential input voltage = +/- 350 mV.

### LVPECL

Depending on whether the device is transmitting or receiving an LVPECL signal, two different circuits are used for LVPECL termination. A sample circuit illustrating a valid termination technique for transmitting LVPECL signals appears in [Figure 56](#). A sample circuit illustrating a valid termination for receiving LVPECL signals appears in [Figure 57](#). [Table 39](#) lists DC voltage specifications. Further information on the specific termination resistor packs shown can be found on [Table 40](#).

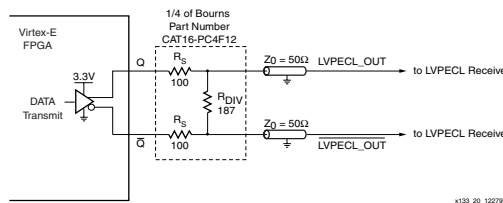

Figure 56: Transmitting LVPECL Signal Circuit

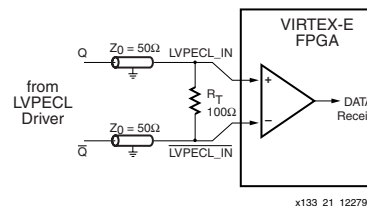

Figure 57: Receiving LVPECL Signal Circuit

Table 39: LVPECL Voltage Specifications

Parameter	Min	Typ	Max
V <sub>CC0</sub>	3.0	3.3	3.6
V <sub>REF</sub>	-	-	-
V <sub>TT</sub>	-	-	-
V <sub>IH</sub>	1.49	-	2.72
V <sub>IL</sub>	0.86	-	2.125
V <sub>OH</sub>	1.8	-	-
V <sub>OL</sub>	-	-	1.57

Note: For more detailed information, see [LVPECL DC Specifications](#)



## Termination Resistor Packs

Resistor packs are available with the values and the configuration required for LVDS and LVPECL termination from Bourns, Inc., as listed in Table. For pricing and availability, please contact Bourns directly at [www.bourns.com](http://www.bourns.com).

Table 40: Bourns LVDS/LVPECL Resistor Packs

Part Number	I/O Standard	Term. for:	Pairs/Pack	Pins
CAT16-LV2F6	LVDS	Driver	2	8
CAT16-LV4F12	LVDS	Driver	4	16
CAT16-PC2F6	LVPECL	Driver	2	8
CAT16-PC4F12	LVPECL	Driver	4	16
CAT16-PT2F2	LVDS/LVPECL	Receiver	2	8
CAT16-PT4F4	LVDS/LVPECL	Receiver	4	16

## LVDS Design Guide

The SelectI/O library elements have been expanded for Virtex-E devices to include new LVDS variants. At this time all of the cells might not be included in the Synthesis libraries. The 2.1i-Service Pack 2 update for Alliance and Foundation software includes these cells in the VHDL and Verilog libraries. It is necessary to combine these cells to create the P-side (positive) and N-side (negative) as described in the input, output, 3-state and bidirectional sections.

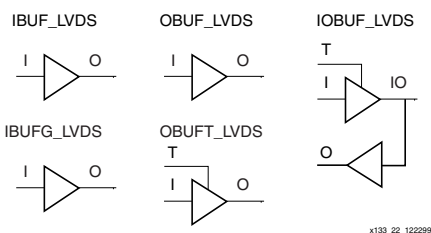

Figure 58: LVDS Elements

## Creating LVDS Global Clock Input Buffers

The global clock input buffer can be combined with the adjacent IOB to form an LVDS clock input buffer. The P-side resides in the GCLKPAD location and the N-side resides in the adjacent IO\_LVDS\_DLL site.

Table 41: Global Clock Input Buffer Pair Locations

Pkg	Pair 3		Pair 2		Pair 2		Pair 0	
	P	N	P	N	P	N	P	N
BG560	A17	C18	D17	E17	AJ17	AM18	AL17	AM17
FG676	E13	B13	C13	F14	AB13	AF13	AA14	AC14
FG900	C15	A15	E15	E16	AK16	AH16	AJ16	AF16

## HDL Instantiation

Only one global clock input buffer is required to be instantiated in the design and placed on the correct GCLKPAD location. The N-side of the buffer is reserved and no other IOB is allowed to be placed on this location.

In the physical device, a configuration option is enabled that routes the pad wire to the differential input buffer located in the GCLKIOB. The output of this buffer then drives the output of the GCLKIOB cell. In EPIC it appears that the second buffer is unused. Any attempt to use this location for another purpose leads to a DRC error in the software.

## VHDL Instantiation

```
gclk0_p : IBUFG_LVDS port map
(I=>clk_external, O=>clk_internal);
```

## Verilog Instantiation

```
IBUFG_LVDS gclk0_p (.I(clk_external),
.O(clk_internal));
```

## Location Constraints

All LVDS buffers must be explicitly placed on a device. For the global clock input buffers this can be done with the following constraint in the UCF or NCF file.

```
NET clk_external LOC = GCLKPAD3;
```

GCLKPAD3 can also be replaced with the package pin name, such as D17 for the BG432 package.

## Optional N-Side

Some designers might prefer to also instantiate the N-side buffer for the global clock buffer. This allows the top-level net list to include net connections for both PCB layout and system-level integration. In this case, only the output P-side IBUFG connection has a net connected to it. Since the N-side IBUFG does not have a connection in the EDIF net list, it is trimmed from the design in MAP.

## VHDL Instantiation

```
gclk0_p : IBUFG_LVDS port map
(I=>clk_p_external, O=>clk_internal);
```

```
gclk0_n : IBUFG_LVDS port map
(I=>clk_n_external, O=>clk_internal);
```

## Verilog Instantiation

```
IBUFG_LVDS gclk0_p (.I(clk_p_external),
.O(clk_internal));
```

```
IBUFG_LVDS gclk0_n (.I(clk_n_external),
.O(clk_internal));
```

## Location Constraints

All LVDS buffers must be explicitly placed on a device. For the global clock input buffers this can be done with the following constraint in the UCF or NCF file.

```
NET clk_p_external LOC = GCLKPAD3;
```

```
NET clk_n_external LOC = C17;
```

GCLKPAD3 can also be replaced with the package pin name, such as D17 for the BG432 package.

## Creating LVDS Input Buffers

An LVDS input buffer can be placed in a wide number of IOB locations. The exact location is dependent on the package that is used. The Virtex-E package information lists the possible locations as IO\_L#P for the P-side and IO\_L#N for the N-side where # is the pair number.

### HDL Instantiation

Only one input buffer is required to be instantiated in the design and placed on the correct IO\_L#P location. The N-side of the buffer is reserved and no other IOB is allowed to be placed on this location. In the physical device, a configuration option is enabled that routes the pad wire from the IO\_L#N IOB to the differential input buffer located in the IO\_L#P IOB. The output of this buffer then drives the output of the IO\_L#P cell or the input register in the IO\_L#P IOB. In EPIC it appears that the second buffer is unused. Any attempt to use this location for another purpose leads to a DRC error in the software.

### VHDL Instantiation

```
data0_p : IBUF_LVDS port map (I=>data(0),
O=>data_int(0));
```

### Verilog Instantiation

```
IBUF_LVDS data0_p (.I(data[0]),
.O(data_int[0]));
```

### Location Constraints

All LVDS buffers must be explicitly placed on a device. For the input buffers this can be done with the following constraint in the UCF or NCF file.

```
NET data<0> LOC = D28; # IO_L0P
```

### Optional N-side

Some designers might prefer to also instantiate the N-side buffer for the input buffer. This allows the top-level net list to include net connections for both PCB layout and system-level integration. In this case, only the output P-side IBUF connection has a net connected to it. Since the N-side IBUF does not have a connection in the EDIF net list, it is trimmed from the design in MAP.

### VHDL Instantiation

```
data0_p : IBUF_LVDS port map
(I=>data_p(0), O=>data_int(0));
data0_n : IBUF_LVDS port map
(I=>data_n(0), O=>open);
```

### Verilog Instantiation

```
IBUF_LVDS data0_p (.I(data_p[0]),
.O(data_int[0]));
IBUF_LVDS data0_n (.I(data_n[0]), .O());
```

## Location Constraints

All LVDS buffers must be explicitly placed on a device. For the global clock input buffers this can be done with the following constraint in the UCF or NCF file.

```
NET data_p<0> LOC = D28; # IO_L0P
NET data_n<0> LOC = B29; # IO_L0N
```

## Adding an Input Register

All LVDS buffers can have an input register in the IOB. The input register is in the P-side IOB only. All the normal IOB register options are available (FD, FDE, FDC, FDCE, FDP, FDPE, FDR, FDRE, FDS, FDSE, LD, LDE, LDC, LDCE, LDP, LDPE). The register elements can be inferred or explicitly instantiated in the HDL code.

The register elements can be packed in the IOB using the IOB property to TRUE on the register or by using “map -pr [ilob]”, where “i” is inputs only, “o” is outputs only, and “b” is both inputs and outputs.

To improve design coding times VHDL and Verilog synthesis macro libraries available to explicitly create these structures. The input library macros are listed in [Table 42](#). The I and IB inputs to the macros are the external net connections.

Table 42: Input Library Macros

Name	Inputs	Outputs
IBUFDS_FD_LVDS	I, IB, C	Q
IBUFDS_FDE_LVDS	I, IB, CE, C	Q
IBUFDS_FDC_LVDS	I, IB, C, CLR	Q
IBUFDS_FDCE_LVDS	I, IB, CE, C, CLR	Q
IBUFDS_FDP_LVDS	I, IB, C, PRE	Q
IBUFDS_FDPE_LVDS	I, IB, CE, C, PRE	Q
IBUFDS_FDR_LVDS	I, IB, C, R	Q
IBUFDS_FDRE_LVDS	I, IB, CE, C, R	Q
IBUFDS_FDS_LVDS	I, IB, C, S	Q
IBUFDS_FDSE_LVDS	I, IB, CE, C, S	Q
IBUFDS_LD_LVDS	I, IB, G	Q
IBUFDS_LDE_LVDS	I, IB, GE, G	Q
IBUFDS_LDC_LVDS	I, IB, G, CLR	Q
IBUFDS_LDCE_LVDS	I, IB, GE, G, CLR	Q
IBUFDS_LDP_LVDS	I, IB, G, PRE	Q
IBUFDS_LDPE_LVDS	I, IB, GE, G, PRE	Q

## Creating LVDS Output Buffers

LVDS output buffer can be placed in wide number of IOB locations. The exact location are dependent on the package that is used. The Virtex-E package information lists the possible locations as IO\_L#P for the P-side and IO\_L#N for the N-side where # is the pair number.

### HDL Instantiation

Both output buffers are required to be instantiated in the design and placed on the correct IO\_L#P and IO\_L#N locations. The IOB must have the same net source the following pins, clock (C), set/reset (SR), output (O), output clock enable (OCE). In addition, the output (O) pins must be inverted with respect to each other, and if output registers are used, the INIT states must be opposite values (one HIGH and one LOW). Failure to follow these rules leads to DRC errors in software.

### VHDL Instantiation

```
data0_p : OBUF_LVDS port map
(I=>data_int(0), O=>data_p(0));

data0_inv: INV      port map
(I=>data_int(0), O=>data_n_int(0));

data0_n : OBUF_LVDS port map
(I=>data_n_int(0), O=>data_n(0));
```

### Verilog Instantiation

```
OBUF_LVDS data0_p (.I(data_int[0]),
.O(data_p[0]));
INV      data0_inv (.I(data_int[0],
.O(data_n_int[0]));
OBUF_LVDS data0_n (.I(data_n_int[0]),
.O(data_n[0]));
```

### Location Constraints

All LVDS buffers must be explicitly placed on a device. For the output buffers this can be done with the following constraint in the UCF or NCF file.

```
NET data_p<0> LOC = D28; # IO_L0P
NET data_n<0> LOC = B29; # IO_L0N
```

### Synchronous vs. Asynchronous Outputs

If the outputs are synchronous (registered in the IOB), then any IO\_L#PIN pair can be used. If the outputs are asynchronous (no output register), then they must use one of the pairs that are part of the same IOB group at the end of a ROW or at the top/bottom of a COLUMN in the device.

The LVDS pairs that can be used as asynchronous outputs are listed in the Virtex-E pinout tables. Some pairs are marked as asynchronous-capable for all devices in that package, and others are marked as available only for that device in the package. If the device size might change at

some point in the product lifetime, then only the common pairs for all packages should be used.

### Adding an Output Register

All LVDS buffers can have an output register in the IOB. The output registers must be in both the P-side and N-side IOBs. All the normal IOB register options are available (FD, FDE, FDC, FDCE, FDP, FDPE, FDR, FDRE, FDS, FDSE, LD, LDE, LDC, LDCE, LDP, LDPE). The register elements can be inferred or explicitly instantiated in the HDL code.

Special care must be taken to insure that the D pins of the registers are inverted and that the INIT states of the registers are opposite. The clock pin (C), clock enable (CE) and set/reset (CLR/PRE or S/R) pins must connect to the same source. Failure to do this leads to a DRC error in the software.

The register elements can be packed in the IOB using the IOB property to TRUE on the register or by using the “map-pr [i|olb]” where “i” is inputs only, “o” is outputs only and “b” is both inputs and outputs.

To improve design coding times VHDL and Verilog synthesis macro libraries have been developed to explicitly create these structures. The output library macros are listed in [Table 43](#). The O and OB inputs to the macros are the external net connections.

*Table 43: Output Library Macros*

Name	Inputs	Outputs
OBUFDS_FD_LVDS	D, C	O, OB
OBUFDS_FDE_LVDS	DD, CE, C	O, OB
OBUFDS_FDC_LVDS	D, C, CLR	O, OB
OBUFDS_FDCE_LVDS	D, CE, C, CLR	O, OB
OBUFDS_FDP_LVDS	D, C, PRE	O, OB
OBUFDS_FDPE_LVDS	D, CE, C, PRE	O, OB
OBUFDS_FDR_LVDS	D, C, R	O, OB
OBUFDS_FDRE_LVDS	D, CE, C, R	O, OB
OBUFDS_FDS_LVDS	D, C, S	O, OB
OBUFDS_FDSE_LVDS	D, CE, C, S	O, OB
OBUFDS_LD_LVDS	D, G	O, OB
OBUFDS_LDE_LVDS	D, GE, G	O, OB
OBUFDS_LDC_LVDS	D, G, CLR	O, OB
OBUFDS_LDCE_LVDS	D, GE, G, CLR	O, OB
OBUFDS_LDP_LVDS	D, G, PRE	O, OB
OBUFDS_LDPE_LVDS	D, GE, G, PRE	O, OB

## Creating LVDS Output 3-State Buffers

LVDS output 3-state buffers can be placed in a wide number of IOB locations. The exact locations are dependent on the package used. The Virtex-E package information lists the possible locations as IO\_L#P for the P-side and IO\_L#N for the N-side, where # is the pair number.

### HDL Instantiation

Both output 3-state buffers are required to be instantiated in the design and placed on the correct IO\_L#P and IO\_L#N locations. The IOB must have the same net source the following pins, clock (C), set/reset (SR), 3-state (T), 3-state clock enable (TCE), output (O), output clock enable (OCE). In addition, the output (O) pins must be inverted with respect to each other, and if output registers are used, the INIT states must be opposite values (one High and one Low). If 3-state registers are used, they must be initialized to the same state. Failure to follow these rules leads to DRC errors in the software.

### VHDL Instantiation

```
data0_p:  OBUFT_LVDS port map
(I=>data_int(0), T=>data_tri,
O=>data_p(0));

data0_inv: INV port map
(I=>data_int(0), O=>data_n_int(0));

data0_n:  OBUFT_LVDS port map
(I=>data_n_int(0), T=>data_tri,
O=>data_n(0));
```

### Verilog Instantiation

```
OBUFT_LVDS data0_p (.I(data_int[0]),
.T(data_tri), .O(data_p[0]));

INV          data0_inv (.I(data_int[0],
.O(data_n_int[0]));

OBUFT_LVDS data0_n (.I(data_n_int[0]),
.T(data_tri), .O(data_n[0]));
```

### Location Constraints

All LVDS buffers must be explicitly placed on a device. For the output buffers this can be done with the following constraint in the UCF or NCF file.

```
NET data_p<0> LOC = D28; # IO_L0P
NET data_n<0> LOC = B29; # IO_L0N
```

### Synchronous vs. Asynchronous 3-State Outputs

If the outputs are synchronous (registered in the IOB), then any IO\_L#PIN pair can be used. If the outputs are asynchronous (no output register), then they must use one of the pairs that are part of the same IOB group at the end of a ROW or at the top/bottom of a COLUMN in the device. This applies for either the 3-state pin or the data out pin.

LVDS pairs that can be used as asynchronous outputs are listed in the Virtex-E pinout tables. Some pairs are marked as “asynchronous capable” for all devices in that package, and others are marked as available only for that device in the package. If the device size might be changed at some point in the product lifetime, then only the common pairs for all packages should be used.

### Adding Output and 3-State Registers

All LVDS buffers can have an output register in the IOB. The output registers must be in both the P-side and N-side IOBs. All the normal IOB register options are available (FD, FDE, FDC, FDCE, FDP, FDPE, FDR, FDRE, FDS, FDSE, LD, LDE, LDC, LDCE, LDP, LDPE). The register elements can be inferred or explicitly instantiated in the HDL code.

Special care must be taken to insure that the D pins of the registers are inverted and that the INIT states of the registers are opposite. The 3-state (T), 3-state clock enable (CE), clock pin (C), output clock enable (CE) and set/reset (CLR/PRE or S/R) pins must connect to the same source. Failure to do this leads to a DRC error in the software.

The register elements can be packed in the IOB using the IOB property to TRUE on the register or by using the “map-pr [ilolb]” where “i” is inputs only, “o” is outputs only and “b” is both inputs and outputs.

To improve design coding times VHDL and Verilog synthesis macro libraries have been developed to explicitly create these structures. The input library macros are listed below. The 3-state is configured to be 3-stated at GSR and when the PRE,CLR,S or R is asserted and shares it's clock enable with the output register. If this is not desirable, the library can be updated by the user for the desired functionality. The O and OB inputs to the macros are the external net connections.

### Creating LVDS Bidirectional Buffer

LVDS bidirectional buffers can be placed in a wide number of IOB locations. The exact locations are dependent on the package used. The Virtex-E package information lists the possible locations as IO\_L#P for the P-side and IO\_L#N for the N-side, where # is the pair number.

### HDL Instantiation

Both bidirectional buffers are required to be instantiated in the design and placed on the correct IO\_L#P and IO\_L#N locations. The IOB must have the same net source the following pins, clock (C), set/reset (SR), 3-state (T), 3-state clock enable (TCE), output (O), output clock enable (OCE). In addition, the output (O) pins must be inverted with respect to each other, and if output registers are used, the INIT states must be opposite values (one HIGH and one LOW). If 3-state registers are used, they must be initialized to the same state. Failure to follow these rules leads to DRC errors in the software.



### VHDL Instantiation

```
data0_p: IOBUF_LVDS port map
(I=>data_out(0), T=>data_tri,
IO=>data_p(0), O=>data_int(0));
data0_inv: INV port map
(I=>data_out(0), O=>data_n_out(0));
data0_n : IOBUF_LVDS port map
(I=>data_n_out(0), T=>data_tri,
IO=>data_n(0), O=>open);
```

### Verilog Instantiation

```
IOBUF_LVDS data0_p(.I(data_out[0]),
.T(data_tri), .IO(data_p[0]),
.O(data_int[0]));
INV data0_inv (.I(data_out[0],
.O(data_n_out[0]));
IOBUF_LVDS
data0_n(.I(data_n_out[0]),.T(data_tri),.
IO(data_n[0]).O());
```

### Location Constraints

All LVDS buffers must be explicitly placed on a device. For the output buffers this can be done with the following constraint in the UCF or NCF file.

```
NET data_p<0> LOC = D28; # IO_L0P
NET data_n<0> LOC = B29; # IO_L0N
```

### Synchronous vs. Asynchronous Bidirectional Buffers

If the output side of the bidirectional buffers are synchronous (registered in the IOB), then any IO\_L#PIN pair can be used. If the output side of the bidirectional buffers are asynchronous (no output register), then they must use one of the pairs that is a part of the asynchronous LVDS IOB group. This applies for either the 3-state pin or the data out pin.

Table 44: Bidirectional I/O Library Macros

Name	Inputs	Bidirectional	Outputs
IOBUFDS_FD_LVDS	D, T, C	IO, IOB	Q
IOBUFDS_FDE_LVDS	D, T, CE, C	IO, IOB	Q
IOBUFDS_FDC_LVDS	D, T, C, CLR	IO, IOB	Q
IOBUFDS_FDCE_LVDS	D, T, CE, C, CLR	IO, IOB	Q
IOBUFDS_FDP_LVDS	D, T, C, PRE	IO, IOB	Q
IOBUFDS_FDPE_LVDS	D, T, CE, C, PRE	IO, IOB	Q
IOBUFDS_FDR_LVDS	D, T, C, R	IO, IOB	Q
IOBUFDS_FDRE_LVDS	D, T, CE, C, R	IO, IOB	Q
IOBUFDS_FDS_LVDS	D, T, C, S	IO, IOB	Q

The LVDS pairs that can be used as asynchronous bidirectional buffers are listed in the Virtex-E pinout tables. Some pairs are marked as asynchronous capable for all devices in that package, and others are marked as available only for that device in the package. If the device size might change at some point in the product's lifetime, then only the common pairs for all packages should be used.

### Adding Output and 3-State Registers

All LVDS buffers can have output and input registers in the IOB. The output registers must be in both the P-side and N-side IOBs, the input register is only in the P-side. All the normal IOB register options are available (FD, FDE, FDC, FDCE, FDP, FDPE, FDR, FDRE, FDS, FDSE, LD, LDE, LDC, LDCE, LDP, LDPE). The register elements can be inferred or explicitly instantiated in the HDL code. Special care must be taken to insure that the D pins of the registers are inverted and that the INIT states of the registers are opposite. The 3-state (T), 3-state clock enable (CE), clock pin (C), output clock enable (CE), and set/reset (CLR/PRE or S/R) pins must connect to the same source. Failure to do this leads to a DRC error in the software.

The register elements can be packed in the IOB using the IOB property to TRUE on the register or by using the "map -pr [ilolb]", where "i" is inputs only, "o" is outputs only, and "b" is both inputs and outputs. To improve design coding times, VHDL and Verilog synthesis macro libraries have been developed to explicitly create these structures. The bidirectional I/O library macros are listed in Table 44.

The 3-state is configured to be 3-stated at GSR and when the PRE, CLR, S, or R is asserted and shares its clock enable with the output and input register. If this is not desirable, then the library can be updated with the desired functionality by the user. The I/O and IOB inputs to the macros are the external net connections.

Table 44: Bidirectional I/O Library Macros (Continued)

Name	Inputs	Bidirectional	Outputs
IOBUFDS_FDSE_LVDS	D, T, CE, C, S	IO, IOB	Q
IOBUFDS_LD_LVDS	D, T, G	IO, IOB	Q
IOBUFDS_LDE_LVDS	D, T, GE, G	IO, IOB	Q
IOBUFDS_LDC_LVDS	D, T, G, CLR	IO, IOB	Q
IOBUFDS_LDCE_LVDS	D, T, GE, G, CLR	IO, IOB	Q
IOBUFDS_LDP_LVDS	D, T, G, PRE	IO, IOB	Q
IOBUFDS_LDPE_LVDS	D, T, GE, G, PRE	IO, IOB	Q

## Revision History

The following table shows the revision history for this document.

Date	Version	Revision
03/23/00	1.0	Initial Xilinx release.
08/01/00	1.1	Accumulated edits and fixes. Upgrade to Preliminary. Preview -8 numbers added. Reformatted to adhere to corporate documentation style guidelines. Minor changes in BG560 pin-out table.
09/19/00	1.2	<ul style="list-style-type: none"> <li>In Table 3 (Module 4), <b>FG676 Fine-Pitch BGA — XCV405E</b>, the following pins are no longer labeled as VREF: B7, G16, G26, W26, AF20, AF8, Y1, H1.</li> <li>Min values added to <b>Virtex-E Electrical Characteristics</b> tables.</li> </ul>
11/20/00	1.3	<ul style="list-style-type: none"> <li>Updated speed grade -8 numbers in <b>Virtex-E Electrical Characteristics</b> tables (Module 3).</li> <li>Updated minimums in Table 11 (Module 2), and added notes to Table 12 (Module 2).</li> <li>Added to note 2 of <b>Absolute Maximum Ratings</b> (Module 3).</li> <li>Changed all minimum hold times to -0.4 for <b>Global Clock Set-Up and Hold for LVTTL Standard, with DLL</b> (Module 3).</li> <li>Revised maximum <math>T_{DLLPW}</math> in -6 speed grade for <b>DLL Timing Parameters</b> (Module 3).</li> </ul>
04/02/01	1.4	<ul style="list-style-type: none"> <li>In <b>Table 4, FG676 Fine-Pitch BGA — XCV405E</b>, pin B19 is no longer labeled as VREF, and pin G16 is now labeled as VREF.</li> <li>Updated values in <b>Virtex-E Switching Characteristics</b> tables.</li> <li>Converted data sheet to modularized format.</li> </ul>
04/19/01	1.5	<ul style="list-style-type: none"> <li>Modified <b>Figure 30</b>, which shows “DLL Generation of 4x Clock in Virtex-E Devices.”</li> </ul>
07/23/01	1.6	<ul style="list-style-type: none"> <li>Made minor edits to text under <b>Configuration</b>.</li> </ul>
11/16/01	2.0	<ul style="list-style-type: none"> <li>Added warning under <b>Configuration</b> section that attempting to load an incorrect bitstream causes configuration to fail and can damage the device.</li> </ul>

## Virtex-E Extended Memory Data Sheet

The Virtex-E Extended Memory Data Sheet contains the following modules:

- DS025-1, Virtex-E 1.8V Extended Memory FPGAs: [Introduction and Ordering Information \(Module 1\)](#)
- DS025-2, Virtex-E 1.8V Extended Memory FPGAs: [Functional Description \(Module 2\)](#)
- DS025-3, Virtex-E 1.8V Extended Memory FPGAs: [DC and Switching Characteristics \(Module 3\)](#)
- DS025-4, Virtex-E 1.8V Extended Memory FPGAs: [Pinout Tables \(Module 4\)](#)