

Virtex Pin Definitions

Table 1: Special Purpose Pins

Pin Name	Dedicated Pin	Direction	Description
GCK0, GCK1, GCK2, GCK3	Yes	Input	Clock input pins that connect to Global Clock Buffers. These pins become user inputs when not needed for clocks.
M0, M1, M2	Yes	Input	Mode pins are used to specify the configuration mode.
CCLK	Yes	Input or Output	The configuration Clock I/O pin: it is an input for SelectMAP and slave-serial modes, and output in master-serial mode. After configuration, it is input only, logic level = Don't Care.
PROGRAM	Yes	Input	Initiates a configuration sequence when asserted Low.
DONE	Yes	Bidirectional	Indicates that configuration loading is complete, and that the start-up sequence is in progress. The output can be open drain.
INIT	No	Bidirectional (Open-drain)	When Low, indicates that the configuration memory is being cleared. The pin becomes a user I/O after configuration.
BUSY/ DOUT	No	Output	In SelectMAP mode, BUSY controls the rate at which configuration data is loaded. The pin becomes a user I/O after configuration unless the SelectMAP port is retained. In bit-serial modes, DOUT provides header information to downstream devices in a daisy-chain. The pin becomes a user I/O after configuration.
D0/DIN, D1, D2, D3, D4, D5, D6, D7	No	Input or Output	In SelectMAP mode, D0 - D7 are configuration data pins. These pins become user I/Os after configuration unless the SelectMAP port is retained. In bit-serial modes, DIN is the single data input. This pin becomes a user I/O after configuration.
WRITE	No	Input	In SelectMAP mode, the active-low Write Enable signal. The pin becomes a user I/O after configuration unless the SelectMAP port is retained.
CS	No	Input	In SelectMAP mode, the active-low Chip Select signal. The pin becomes a user I/O after configuration unless the SelectMAP port is retained.
TDI, TDO, TMS, TCK	Yes	Mixed	Boundary-scan Test-Access-Port pins, as defined in IEEE 1149.1.
DXN, DXP	Yes	N/A	Temperature-sensing diode pins. (Anode: DXP, cathode: DXN)
V _{CCINT}	Yes	Input	Power-supply pins for the internal core logic.
V _{CCO}	Yes	Input	Power-supply pins for the output drivers (subject to banking rules)
V _{REF}	No	Input	Input threshold voltage pins. Become user I/Os when an external threshold voltage is not needed (subject to banking rules).
GND	Yes	Input	Ground

Virtex Pinout Information

Pinout Tables

See www.xilinx.com for updates or additional pinout information. For convenience, [Table 2](#), [Table 3](#) and [Table 4](#) list the locations of special-purpose and power-supply pins. Pins not listed are either user I/Os or not connected, depending on the device/package combination. See the Pinout Diagrams starting on [page 17](#) for any pins not listed for a particular part/package combination.

Table 2: Virtex Pinout Tables (Chip-Scale and QFP Packages)

Pin Name	Device	CS144	TQ144	PQ/HQ240
GCK0	All	K7	90	92
GCK1	All	M7	93	89
GCK2	All	A7	19	210
GCK3	All	A6	16	213
M0	All	M1	110	60
M1	All	L2	112	58
M2	All	N2	108	62
CCLK	All	B13	38	179
PROGRAM	All	L12	72	122
DONE	All	M12	74	120
INIT	All	L13	71	123
BUSY/DOOUT	All	C11	39	178
D0/DIN	All	C12	40	177
D1	All	E10	45	167
D2	All	E12	47	163
D3	All	F11	51	156
D4	All	H12	59	145
D5	All	J13	63	138
D6	All	J11	65	134
D7	All	K10	70	124
WRITE	All	C10	32	185
CS	All	D10	33	184
TDI	All	A11	34	183
TDO	All	A12	36	181
TMS	All	B1	143	2
TCK	All	C3	2	239
V _{CCINT}	All	A9, B6, C5, G3, G12, M5, M9, N6	10, 15, 25, 57, 84, 94, 99, 126	16, 32, 43, 77, 88, 104, 137, 148, 164, 198, 214, 225

Table 2: Virtex Pinout Tables (Chip-Scale and QFP Packages) (Continued)

Pin Name	Device	CS144	TQ144	PQ/HQ240
V_{CCO}	All	Banks 0 and 1: A2, A13, D7 Banks 2 and 3: B12, G11, M13 Banks 4 and 5: N1, N7, N13 Banks 6 and 7: B2, G2, M2	No I/O Banks in this package: 1, 17, 37, 55, 73, 92, 109, 128	No I/O Banks in this package: 15, 30, 44, 61, 76, 90, 105, 121, 136, 150, 165, 180, 197, 212, 226, 240
V_{REF} Bank 0 (V_{REF} pins are listed incrementally. Connect all pins listed for both the required device and all smaller devices listed in the same package.) Within each bank, if input reference voltage is not required, all V_{REF} pins are general I/O.	XCV50	C4, D6	5, 13	218, 232
	XCV100/150	... + B4	... + 7	... + 229
	XCV200/300	N/A	N/A	... + 236
	XCV400	N/A	N/A	... + 215
	XCV600	N/A	N/A	... + 230
	XCV800	N/A	N/A	... + 222
V_{REF} Bank 1 (V_{REF} pins are listed incrementally. Connect all pins listed for both the required device and all smaller devices listed in the same package.) Within each bank, if input reference voltage is not required, all V_{REF} pins are general I/O.	XCV50	A10, B8	22, 30	191, 205
	XCV100/150	... + D9	... + 28	... + 194
	XCV200/300	N/A	N/A	... + 187
	XCV400	N/A	N/A	... + 208
	XCV600	N/A	N/A	... + 193
	XCV800	N/A	N/A	... + 201
V_{REF} Bank 2 (V_{REF} pins are listed incrementally. Connect all pins listed for both the required device and all smaller devices listed in the same package.) Within each bank, if input reference voltage is not required, all V_{REF} pins are general I/O.	XCV50	D11, F10	42, 50	157, 171
	XCV100/150	... + D13	... + 44	... + 168
	XCV200/300	N/A	N/A	... + 175
	XCV400	N/A	N/A	... + 154
	XCV600	N/A	N/A	... + 169
	XCV800	N/A	N/A	... + 161

Table 2: Virtex Pinout Tables (Chip-Scale and QFP Packages) (Continued)

Pin Name	Device	CS144	TQ144	PQ/HQ240
V_{REF} Bank 3 (V _{REF} pins are listed incrementally. Connect all pins listed for both the required device and all smaller devices listed in the same package.) Within each bank, if input reference voltage is not required, all V _{REF} pins are general I/O.	XCV50	H11, K12	60, 68	130, 144
	XCV100/150	... + J10	... + 66	... + 133
	XCV200/300	N/A	N/A	... + 126
	XCV400	N/A	N/A	... + 147
	XCV600	N/A	N/A	... + 132
	XCV800	N/A	N/A	... + 140
V_{REF} Bank 4 (V _{REF} pins are listed incrementally. Connect all pins listed for both the required device and all smaller devices listed in the same package.) Within each bank, if input reference voltage is not required, all V _{REF} pins are general I/O.	XCV50	L8, L10	79, 87	97, 111
	XCV100/150	... + N10	... + 81	... + 108
	XCV200/300	N/A	N/A	... + 115
	XCV400	N/A	N/A	... + 94
	XCV600	N/A	N/A	... + 109
	XCV800	N/A	N/A	... + 101
V_{REF} Bank 5 (V _{REF} pins are listed incrementally. Connect all pins listed for both the required device and all smaller devices listed in the same package.) Within each bank, if input reference voltage is not required, all V _{REF} pins are general I/O.	XCV50	L4, L6	96, 104	70, 84
	XCV100/150	... + N4	... + 102	... + 73
	XCV200/300	N/A	N/A	... + 66
	XCV400	N/A	N/A	... + 87
	XCV600	N/A	N/A	... + 72
	XCV800	N/A	N/A	... + 80

Table 2: Virtex Pinout Tables (Chip-Scale and QFP Packages) (Continued)

Pin Name	Device	CS144	TQ144	PQ/HQ240
V _{REF} Bank 6 (V _{REF} pins are listed incrementally. Connect all pins listed for both the required device and all smaller devices listed in the same package.) Within each bank, if input reference voltage is not required, all V _{REF} pins are general I/O.	XCV50	H2, K1	116, 123	36, 50
	XCV100/150	... + J3	... + 118	... + 47
	XCV200/300	N/A	N/A	... + 54
	XCV400	N/A	N/A	... + 33
	XCV600	N/A	N/A	... + 48
	XCV800	N/A	N/A	... + 40
V _{REF} Bank 7 (V _{REF} pins are listed incrementally. Connect all pins listed for both the required device and all smaller devices listed in the same package.) Within each bank, if input reference voltage is not required, all V _{REF} pins are general I/O.	XCV50	D4, E1	133, 140	9, 23
	XCV100/150	... + D2	... + 138	... + 12
	XCV200/300	N/A	N/A	... + 5
	XCV400	N/A	N/A	... + 26
	XCV600	N/A	N/A	... + 11
	XCV800	N/A	N/A	... + 19
GND	All	A1, B9, B11, C7, D5, E4, E11, F1, G10, J1, J12, L3, L5, L7, L9, N12	9, 18, 26, 35, 46, 54, 64, 75, 83, 91, 100, 111, 120, 129, 136, 144,	1, 8, 14, 22, 29, 37, 45, 51, 59, 69, 75, 83, 91, 98, 106, 112, 119, 129, 135, 143, 151, 158, 166, 172, 182, 190, 196, 204, 211, 219, 227, 233

Table 3: Virtex Pinout Tables (BGA)

Pin Name	Device	BG256	BG352	BG432	BG560
GCK0	All	Y11	AE13	AL16	AL17
GCK1	All	Y10	AF14	AK16	AJ17
GCK2	All	A10	B14	A16	D17
GCK3	All	B10	D14	D17	A17
M0	All	Y1	AD24	AH28	AJ29
M1	All	U3	AB23	AH29	AK30
M2	All	W2	AC23	AJ28	AN32
CCLK	All	B19	C3	D4	C4
PROGRAM	All	Y20	AC4	AH3	AM1
DONE	All	W19	AD3	AH4	AJ5
INIT	All	U18	AD2	AJ2	AH5
BUSY/DOOUT	All	D18	E4	D3	D4
D0/DIN	All	C19	D3	C2	E4
D1	All	E20	G1	K4	K3
D2	All	G19	J3	K2	L4
D3	All	J19	M3	P4	P3
D4	All	M19	R3	V4	W4
D5	All	P19	U4	AB1	AB5
D6	All	T20	V3	AB3	AC4
D7	All	V19	AC3	AG4	AJ4
WRITE	All	A19	D5	B4	D6
CS	All	B18	C4	D5	A2
TDI	All	C17	B3	B3	D5
TDO	All	A20	D4	C4	E6
TMS	All	D3	D23	D29	B33
TCK	All	A1	C24	D28	E29
DXN	All	W3	AD23	AH27	AK29
DXP	All	V4	AE24	AK29	AJ28

Table 3: Virtex Pinout Tables (BGA) (Continued)

Pin Name	Device	BG256	BG352	BG432	BG560
V _{CCINT} Notes: <ul style="list-style-type: none"> Superset includes all pins, including the ones in bold type. Subset excludes pins in bold type. In BG352, for XCV300 all the V_{CCINT} pins in the superset must be connected. For XCV150/200, V_{CCINT} pins in the subset must be connected, and pins in bold type can be left unconnected (these unconnected pins cannot be used as user I/O.) In BG432, for XCV400/600/800 all V_{CCINT} pins in the superset must be connected. For XCV300, V_{CCINT} pins in the subset must be connected, and pins in bold type can be left unconnected (these unconnected pins cannot be used as user I/O.) In BG560, for XCV800/1000 all V_{CCINT} pins in the superset must be connected. For XCV400/600, V_{CCINT} pins in the subset must be connected, and pins in bold type can be left unconnected (these unconnected pins cannot be used as user I/O.) 	XCV50/100	C10, D6, D15, F4, F17, L3, L18, R4, R17, U6, U15, V10	N/A	N/A	N/A
	XCV150/200/300	Same as above	A20, C14, D10, J24, K4, P2, P25, V24, W2, AC10, AE14, AE19, B16, D12, L1, L25, R23, T1, AF11, AF16	A10, A17, B23, C14, C19, K3, K29, N2, N29, T1, T29, W2, W31, AB2, AB30, AJ10, AJ16, AK13, AK19, AK22, B26, C7, F1, F30, AE29, AF1, AH8, AH24	N/A
	XCV400/600/800/1000	N/A	N/A	Same as above	A21, B14, B18, B28, C24, E9, E12, F2, H30, J1, K32, N1, N33, U5, U30, Y2, Y31, AD2, AD32, AG3, AG31, AK8, AK11, AK17, AK20, AL14, AL27, AN25, B12, C22, M3, N29, AB2, AB32, AJ13, AL22
V _{CCO} , Bank 0	All	D7, D8	A17, B25, D19	A21, C29, D21	A22, A26, A30, B19, B32
V _{CCO} , Bank 1	All	D13, D14	A10, D7, D13	A1, A11, D11	A10, A16, B13, C3, E5
V _{CCO} , Bank 2	All	G17, H17	B2, H4, K1	C3, L1, L4	B2, D1, H1, M1, R2
V _{CCO} , Bank 3	All	N17, P17	P4, U1, Y4	AA1, AA4, AJ3	V1, AA2, AD1, AK1, AL2
V _{CCO} , Bank 4	All	U13, U14	AC8, AE2, AF10	AH11, AL1, AL11	AM2, AM15, AN4, AN8, AN12
V _{CCO} , Bank 5	All	U7, U8	AC14, AC20, AF17	AH21, AJ29, AL21	AL31, AM21, AN18, AN24, AN30
V _{CCO} , Bank 6	All	N4, P4	U26, W23, AE25	AA28, AA31, AL31	W32, AB33, AF33, AK33, AM32

Table 3: Virtex Pinout Tables (BGA) (Continued)

Pin Name	Device	BG256	BG352	BG432	BG560
V _{CCO} , Bank 7	All	G4, H4	G23, K26, N23	A31, L28, L31	C32, D33, K33, N32, T33
V _{REF} Bank 0 (V _{REF} pins are listed incrementally. Connect all pins listed for both the required device and all smaller devices listed in the same package.) Within each bank, if input reference voltage is not required, all V _{REF} pins are general I/O.	XCV50	A8, B4	N/A	N/A	N/A
	XCV100/150	... + A4	A16,C19, C21	N/A	N/A
	XCV200/300	... + A2	... + D21	B19, D22, D24, D26	N/A
	XCV400	N/A	N/A	... + C18	A19, D20, D26, E23, E27
	XCV600	N/A	N/A	... + C24	... + E24
	XCV800	N/A	N/A	... + B21	... + E21
	XCV1000	N/A	N/A	N/A	... + D29
V _{REF} Bank 1 (V _{REF} pins are listed incrementally. Connect all pins listed for both the required device and all smaller devices listed in the same package.) Within each bank, if input reference voltage is not required, all V _{REF} pins are general I/O.	XCV50	A17, B12	N/A	N/A	N/A
	XCV100/150	... + B15	B6, C9, C12	N/A	N/A
	XCV200/300	... + B17	... + D6	A13, B7, C6, C10	N/A
	XCV400	N/A	N/A	... + B15	A6, D7, D11, D16, E15
	XCV600	N/A	N/A	... + D10	... + D10
	XCV800	N/A	N/A	... + B12	... + D13
	XCV1000	N/A	N/A	N/A	... + E7
V _{REF} Bank 2 (V _{REF} pins are listed incrementally. Connect all pins listed for both the required device and all smaller devices listed in the same package.) Within each bank, if input reference voltage is not required, all V _{REF} pins are general I/O.	XCV50	C20, J18	N/A	N/A	N/A
	XCV100/150	... + F19	E2, H2, M4	N/A	N/A
	XCV200/300	... + G18	... + D2	E2, G3, J2, N1	N/A
	XCV400	N/A	N/A	... + R3	G5, H4, L5, P4, R1
	XCV600	N/A	N/A	... + H1	... + K5
	XCV800	N/A	N/A	... + M3	... + N5
	XCV1000	N/A	N/A	N/A	... + B3

Table 3: Virtex Pinout Tables (BGA) (Continued)

Pin Name	Device	BG256	BG352	BG432	BG560
V_{REF} Bank 3 (V _{REF} pins are listed incrementally. Connect all pins listed for both the required device and all smaller devices listed in the same package.) Within each bank, if input reference voltage is not required, all V _{REF} pins are general I/O.	XCV50	M18, V20	N/A	N/A	N/A
	XCV100/150	... + R19	R4, V4, Y3	N/A	N/A
	XCV200/300	... + P18	... + AC2	V2, AB4, AD4, AF3	N/A
	XCV400	N/A	N/A	... + U2	V4, W5, AD3, AE5, AK2
	XCV600	N/A	N/A	... + AC3	... + AF1
	XCV800	N/A	N/A	... + Y3	... + AA4
	XCV1000	N/A	N/A	N/A	... + AH4
V_{REF} Bank 4 (V _{REF} pins are listed incrementally. Connect all pins listed for both the required device and all smaller devices listed in the same package.) Within each bank, if input reference voltage is not required, all V _{REF} pins are general I/O.	XCV50	V12, Y18	N/A	N/A	N/A
	XCV100/150	... + W15	AC12, AE5, AE8,	N/A	N/A
	XCV200/300	... + V14	... + AE4	AJ7, AL4, AL8, AL13	N/A
	XCV400	N/A	N/A	... + AK15	AL7, AL10, AL16, AM4, AM14
	XCV600	N/A	N/A	... + AK8	... + AL9
	XCV800	N/A	N/A	... + AJ12	... + AK13
	XCV1000	N/A	N/A	N/A	... + AN3
V_{REF} Bank 5 (V _{REF} pins are listed incrementally. Connect all pins listed for both the required device and all smaller devices listed in the same package.) Within each bank, if input reference voltage is not required, all V _{REF} pins are general I/O.	XCV50	V9, Y3	N/A	N/A	N/A
	XCV100/150	... + W6	AC15, AC18, AD20	N/A	N/A
	XCV200/300	... + V7	... + AE23	AJ18, AJ25, AK23, AK27	N/A
	XCV400	N/A	N/A	... + AJ17	AJ18, AJ25, AL20, AL24, AL29
	XCV600	N/A	N/A	... + AL24	... + AM26
	XCV800	N/A	N/A	... + AH19	... + AN23
	XCV1000	N/A	N/A	N/A	... + AK28
V_{REF} Bank 6 (V _{REF} pins are listed incrementally. Connect all pins listed for both the required device and all smaller devices listed in the same package.) Within each bank, if input reference voltage is not required, all V _{REF} pins are general I/O.	XCV50	M2, R3	N/A	N/A	N/A
	XCV100/150	... + T1	R24, Y26, AA25,	N/A	N/A
	XCV200/300	... + T3	... + AD26	V28, AB28, AE30, AF28	N/A
	XCV400	N/A	N/A	... + U28	V29, Y32, AD31, AE29, AK32
	XCV600	N/A	N/A	... + AC28	... + AE31
	XCV800	N/A	N/A	... + Y30	... + AA30
	XCV1000	N/A	N/A	N/A	... + AH30

Table 3: Virtex Pinout Tables (BGA) (Continued)

Pin Name	Device	BG256	BG352	BG432	BG560
V_{REF} Bank 7 (V _{REF} pins are listed incrementally. Connect all pins listed for both the required device and all smaller devices listed in the same package.) Within each bank, if input reference voltage is not required, all V _{REF} pins are general I/O.	XCV50	G3, H1	N/A	N/A	N/A
	XCV100/150	... + D1	D26, G26, L26	N/A	N/A
	XCV200/300	... + B2	... + E24	F28, F31, J30, N30	N/A
	XCV400	N/A	N/A	... + R31	E31, G31, K31, P31, T31
	XCV600	N/A	N/A	... + J28	... + H32
	XCV800	N/A	N/A	... + M28	... + L33
	XCV1000	N/A	N/A	N/A	... + D31
GND	All	C3, C18, D4, D5, D9, D10, D11, D12, D16, D17, E4, E17, J4, J17, K4, K17, L4, L17, M4, M17, T4, T17, U4, U5, U9, U10, U11, U12, U16, U17, V3, V18	A1, A2, A5, A8, A14, A19, A22, A25, A26, B1, B26, E1, E26, H1, H26, N1, P26, W1, W26, AB1, AB26, AE1, AE26, AF1, AF2, AF5, AF8, AF13, AF19, AF22, AF25, AF26	A2, A3, A7, A9, A14, A18, A23, A25, A29, A30, B1, B2, B30, B31, C1, C31, D16, G1, G31, J1, J31, P1, P31, T4, T28, V1, V31, AC1, AC31, AE1, AE31, AH16, AJ1, AJ31, AK1, AK2, AK30, AK31, AL2, AL3, AL7, AL9, AL14, AL18, AL23, AL25, AL29, AL30	A1, A7, A12, A14, A18, A20, A24, A29, A32, A33, B1, B6, B9, B15, B23, B27, B31, C2, E1, F32, G2, G33, J32, K1, L2, M33, P1, P33, R32, T1, V33, W2, Y1, Y33, AB1, AC32, AD33, AE2, AG1, AG32, AH2, AJ33, AL32, AM3, AM7, AM11, AM19, AM25, AM28, AM33, AN1, AN2, AN5, AN10, AN14, AN16, AN20, AN22, AN27, AN33
GND ⁽¹⁾	All	J9, J10, J11, J12, K9, K10, K11, K12, L9, L10, L11, L12, M9, M10, M11, M12	N/A	N/A	N/A
No Connect	All	N/A	N/A	N/A	C31, AC2, AK4, AL3

Notes:

1. 16 extra balls (grounded) at package center.

Table 4: Virtex Pinout Tables (Fine-Pitch BGA)

Pin Name	Device	FG256	FG456	FG676	FG680
GCK0	All	N8	W12	AA14	AW19
GCK1	All	R8	Y11	AB13	AU22
GCK2	All	C9	A11	C13	D21
GCK3	All	B8	C11	E13	A20
M0	All	N3	AB2	AD4	AT37
M1	All	P2	U5	W7	AU38
M2	All	R3	Y4	AB6	AT35
CCLK	All	D15	B22	D24	E4
PROGRAM	All	P15	W20	AA22	AT5
DONE	All	R14	Y19	AB21	AU5
INIT	All	N15	V19	Y21	AU2
BUSY/DOUT	All	C15	C21	E23	E3
D0/DIN	All	D14	D20	F22	C2
D1	All	E16	H22	K24	P4
D2	All	F15	H20	K22	P3
D3	All	G16	K20	M22	R1
D4	All	J16	N22	R24	AD3
D5	All	M16	R21	U23	AG2
D6	All	N16	T22	V24	AH1
D7	All	N14	Y21	AB23	AR4
WRITE	All	C13	A20	C22	B4
CS	All	B13	C19	E21	D5
TDI	All	A15	B20	D22	B3
TDO	All	B14	A21	C23	C4
TMS	All	D3	D3	F5	E36
TCK	All	C4	C4	E6	C36
DXN	All	R4	Y5	AB7	AV37
DXP	All	P4	V6	Y8	AU35

Table 4: Virtex Pinout Tables (Fine-Pitch BGA) (Continued)

Pin Name	Device	FG256	FG456	FG676	FG680
V _{CCINT}	All	C3, C14, D4, D13, E5, E12, M5, M12, N4, N13, P3, P14	E5, E18, F6, F17, G7, G8, G9, G14, G15, G16, H7, H16, J7, J16, P7, P16, R7, R16, T7, T8, T9, T14, T15, T16, U6, U17, V5, V18	G7, G20, H8, H19, J9, J10, J11, J16, J17, J18, K9, K18, L9, L18, T9, T18, U9, U18, V9, V10, V11, V16, V17, V18, W8, W19, Y7, Y20	AD5, AD35, AE5, AE35, AL5, AL35, AM5, AM35, AR8, AR9, AR15, AR16, AR24, AR25, AR31, AR32, E8, E9, E15, E16, E24, E25, E31, E32, H5, H35, J5, J35, R5, R35, T5, T35
V _{CCO} , Bank 0	All	E8, F8	F7, F8, F9, F10, G10, G11	H9, H10, H11, H12, J12, J13	E26, E27, E29, E30, E33, E34
V _{CCO} , Bank 1	All	E9, F9	F13, F14, F15, F16, G12, G13	H15, H16, H17, H18, J14, J15	E6, E7, E10, E11, E13, E14
V _{CCO} , Bank 2	All	H11, H12	G17, H17, J17, K16, K17, L16	J19, K19, L19, M18, M19, N18	F5, G5, K5, L5, N5, P5
V _{CCO} , Bank 3	All	J11, J12	M16, N16, N17, P17, R17, T17	P18, R18, R19, T19, U19, V19	AF5, AG5, AN5, AK5, AJ5, AP5
V _{CCO} , Bank 4	All	L9, M9	T12, T13, U13, U14, U15, U16,	V14, V15, W15, W16, W17, W18	AR6, AR7, AR10, AR11, AR13, AR14
V _{CCO} , Bank 5	All	L8, M8	T10, T11, U7, U8, U9, U10	V12, V13, W9, W10, W11, W12	AR26, AR27, AR29, AR30, AR33, AR34
V _{CCO} , Bank 6	All	J5, J6	M7, N6, N7, P6, R6, T6	P9, R8, R9, T8, U8, V8	AF35, AG35, AJ35, AK35, AN35, AP35
V _{CCO} , Bank 7	All	H5, H6	G6, H6, J6, K6, K7, L7	J8, K8, L8, M8, M9, N9	F35, G35, K35, L35, N35, P35
V _{REF} , Bank 0 (VREF pins are listed incrementally. Connect all pins listed for both the required device and all smaller devices listed in the same package.) Within each bank, if input reference voltage is not required, all V _{REF} pins are general I/O.	XCV50	B4, B7	N/A	N/A	N/A
	XCV100/150	... + C6	A9, C6, E8	N/A	N/A
	XCV200/300	... + A3	... + B4	N/A	N/A
	XCV400	N/A	N/A	A12, C11, D6, E8, G10	
	XCV600	N/A	N/A	... + B7	A33, B28, B30, C23, C24, D33
	XCV800	N/A	N/A	... + B10	... + A26
	XCV1000	N/A	N/A	N/A	... + D34

Table 4: Virtex Pinout Tables (Fine-Pitch BGA) (Continued)

Pin Name	Device	FG256	FG456	FG676	FG680
V_{REF} Bank 1 (V _{REF} pins are listed incrementally. Connect all pins listed for both the required device and all smaller devices listed in the same package.) Within each bank, if input reference voltage is not required, all V _{REF} pins are general I/O.	XCV50	B9, C11	N/A	N/A	N/A
	XCV100/150	... + E11	A18, B13, E14	N/A	N/A
	XCV200/300	... + A14	... + A19	N/A	N/A
	XCV400	N/A	N/A	A14, C20, C21, D15, G16	N/A
	XCV600	N/A	N/A	... + B19	B6, B8, B18, D11, D13, D17
	XCV800	N/A	N/A	... + A17	... + B14
	XCV1000	N/A	N/A	N/A	... + B5
V_{REF} Bank 2 (V _{REF} pins are listed incrementally. Connect all pins listed for both the required device and all smaller devices listed in the same package.) Within each bank, if input reference voltage is not required, all V _{REF} pins are general I/O.	XCV50	F13, H13	N/A	N/A	N/A
	XCV100/150	... + F14	F21, H18, K21	N/A	N/A
	XCV200/300	... + E13	... + D22	N/A	N/A
	XCV400	N/A	N/A	F24, H23, K20, M23, M26	N/A
	XCV600	N/A	N/A	... + G26	G1, H4, J1, L2, V5, W3
	XCV800	N/A	N/A	... + K25	... + N1
	XCV1000	N/A	N/A	N/A	... + D2
V_{REF} Bank 3 (V _{REF} pins are listed incrementally. Connect all pins listed for both the required device and all smaller devices listed in the same package.) Within each bank, if input reference voltage is not required, all V _{REF} pins are general I/O.	XCV50	K16, L14	N/A	N/A	N/A
	XCV100/150	... + L13	N21, R19, U21	N/A	N/A
	XCV200/300	... + M13	... + U20	N/A	N/A
	XCV400	N/A	N/A	R23, R25, U21, W22, W23	N/A
	XCV600	N/A	N/A	... + W26	AC1, AJ2, AK3, AL4, AR1, Y1
	XCV800	N/A	N/A	... + U25	... + AF3
	XCV1000	N/A	N/A	N/A	... + AP4

Table 4: Virtex Pinout Tables (Fine-Pitch BGA) (Continued)

Pin Name	Device	FG256	FG456	FG676	FG680
V_{REF} Bank 4 (V _{REF} pins are listed incrementally. Connect all pins listed for both the required device and all smaller devices listed in the same package.) Within each bank, if input reference voltage is not required, all V _{REF} pins are general I/O.	XCV50	P9, T12	N/A	N/A	N/A
	XCV100/150	... + T11	AA13, AB16, AB19	N/A	N/A
	XCV200/300	... + R13	... + AB20	N/A	N/A
	XCV400	N/A	N/A	AC15, AD18, AD21, AD22, AF15	N/A
	XCV600	N/A	N/A	... + AF20	AT19, AU7, AU17, AV8, AV10, AW11
	XCV800	N/A	N/A	... + AF17	... + AV14
	XCV1000	N/A	N/A	N/A	... + AU6
V_{REF} Bank 5 (V _{REF} pins are listed incrementally. Connect all pins listed for both the required device and all smaller devices listed in the same package.) Within each bank, if input reference voltage is not required, all V _{REF} pins are general I/O.	XCV50	T4, P8	N/A	N/A	N/A
	XCV100/150	... + R5	W8, Y10, AA5	N/A	N/A
	XCV200/300	... + T2	... + Y6	N/A	N/A
	XCV400	N/A	N/A	AA10, AB8, AB12, AC7, AF12	N/A
	XCV600	N/A	N/A	... + AF8	AT27, AU29, AU31, AV35, AW21, AW23
	XCV800	N/A	N/A	... + AE10	... + AT25
	XCV1000	N/A	N/A	N/A	... + AV36
V_{REF} Bank 6 (V _{REF} pins are listed incrementally. Connect all pins listed for both the required device and all smaller devices listed in the same package.) Within each bank, if input reference voltage is not required, all V _{REF} pins are general I/O.	XCV50	J3, N1	N/A	N/A	N/A
	XCV100/150	... + M1	N2, R4, T3	N/A	N/A
	XCV200/300	... + N2	... + Y1	N/A	N/A
	XCV400	N/A	N/A	AB3, R1, R4, U6, V5	N/A
	XCV600	N/A	N/A	... + Y1	AB35, AD37, AH39, AK39, AM39, AN36
	XCV800	N/A	N/A	... + U2	... + AE39
	XCV1000	N/A	N/A	N/A	... + AT39

Table 4: Virtex Pinout Tables (Fine-Pitch BGA) (Continued)

Pin Name	Device	FG256	FG456	FG676	FG680
V _{REF} Bank 7 (V _{REF} pins are listed incrementally. Connect all pins listed for both the required device and all smaller devices listed in the same package.) Within each bank, if input reference voltage is not required, all V _{REF} pins are general I/O.	XCV50	C1, H3	N/A	N/A	N/A
	XCV100/150	... + D1	E2, H4, K3	N/A	N/A
	XCV200/300	... + B1	... + D2	N/A	N/A
	XCV400	N/A	N/A	F4, G4, K6, M2, M5	N/A
	XCV600	N/A	N/A	... + H1	E38, G38, L36, N36, U36, U38
	XCV800	N/A	N/A	... + K1	... + N38
	XCV1000	N/A	N/A	N/A	... + F36
GND	All	A1, A16, B2, B15, F6, F7, F10, F11, G6, G7, G8, G9, G10, G11, H7, H8, H9, H10, J7, J8, J9, J10, K6, K7, K8, K9, K10, K11, L6, L7, L10, L11, R2, R15, T1, T16	A1, A22, B2, B21, C3, C20, J9, J10, J11, J12, J13, J14, K9, K10, K11, K12, K13, K14, L9, L10, L11, L12, L13, L14, M9, M10, M11, M12, M13, M14, N9, N10, N11, N12, N13, N14, P9, P10, P11, P12, P13, P14, Y3, Y20, AA2, AA21, AB1, AB22	A1, A26, B2, B9, B14, B18, B25, C3, C24, D4, D23, E5, E22, J2, J25, K10, K11, K12, K13, K14, K15, K16, K17, L10, L11, L12, L13, L14, L15, L16, L17, M10, M11, M12, M13, M14, M15, M16, M17, N2, N10, N11, N12, N13, N14, N15, N16, N17, P10, P11, P12, P13, P14, P15, P16, P17, P25, R10, R11, R12, R13, R14, R15, R16, R17, T10, T11, T12, T13, T14, T15, T16, T17, U10, U11, U12, U13, U14, U15, U16, U17, V2, V25, AB5, AB22, AC4, AC23, AD3, AD24, AE2, AE9, AE13, AE18, AE25, AF1, AF26	A1, A2, A3, A37, A38, A39, AA5, AA35, AH4, AH5, AH35, AH36, AR5, AR12, AR19, AR20, AR21, AR28, AR35, AT4, AT12, AT20, AT28, AT36, AU1, AU3, AU20, AU37, AU39, AV1, AV2, AV38, AV39, AW1, AW2, AW3, AW37, AW38, AW39, B1, B2, B38, B39, C1, C3, C20, C37, C39, D4, D12, D20, D28, D36, E5, E12, E19, E20, E21, E28, E35, M4, M5, M35, M36, W5, W35, Y3, Y4, Y5, Y35, Y36, Y37

Table 4: Virtex Pinout Tables (Fine-Pitch BGA) (Continued)

Pin Name	Device	FG256	FG456	FG676	FG680
No Connect (No-connect pins are listed incrementally. All pins listed for both the required device and all larger devices listed in the same package are no connects.)	XCV800	N/A	N/A	A2, A3, A15, A25, B1, B6, B11, B16, B21, B24, B26, C1, C2, C25, C26, F2, F6, F21, F25, L2, L25, N25, P2, T2, T25, AA2, AA6, AA21, AA25, AD1, AD2, AD25, AE1, AE3, AE6, AE11, AE14, AE16, AE21, AE24, AE26, AF2, AF24, AF25	N/A
	XCV600	N/A	N/A	same as above	N/A
	XCV400	N/A	N/A	... + A9, A10, A13, A16, A24, AC1, AC25, AE12, AE15, AF3, AF10, AF11, AF13, AF14, AF16, AF18, AF23, B4, B12, B13, B15, B17, D1, D25, H26, J1, K26, L1, M1, M25, N1, N26, P1, P26, R2, R26, T1, T26, U26, V1	N/A
	XCV300	N/A	D4, D19, W4, W19	N/A	N/A
	XCV200	N/A	... + A2, A6, A12, B11, B16, C2, D1, D18, E17, E19, G2, G22, L2, L19, M2, M21, R3, R20, U3, U18, Y22, AA1, AA3, AA11, AA16, AB7, AB12, AB21,	N/A	N/A
	XCV150	N/A	... + A13, A14, C8, C9, E13, F11, H21, J1, J4, K2, K18, K19, M17, N1, P1, P5, P22, R22, W13, W15, AA9, AA10, AB8, AB14	N/A	N/A

Pinout Diagrams

The following diagrams, **CS144 Pin Function Diagram**, page 17 through **FG680 Pin Function Diagram**, page 27, illustrate the locations of special-purpose pins on Virtex FPGAs. **Table 5** lists the symbols used in these diagrams. The diagrams also show I/O-bank boundaries.

Table 5: Pinout Diagram Symbols

Symbol	Pin Function
*	General I/O
*	Device-dependent general I/O, n/c on smaller devices
V	V _{CCINT}
v	Device-dependent V _{CCINT} , n/c on smaller devices
O	V _{CCO}
R	V _{REF}
r	Device-dependent V _{REF} , remains I/O on smaller devices
G	Ground
∅, 1, 2, 3	Global Clocks

Table 5: Pinout Diagram Symbols (Continued)

Symbol	Pin Function
⑩, ①, ②	M0, M1, M2
⑩, ①, ②, ③, ④, ⑤, ⑥, ⑦	D0/DIN, D1, D2, D3, D4, D5, D6, D7
B	DOUT/BUSY
D	DONE
P	PROGRAM
I	INIT
K	CCLK
W	WRITE
S	CS
T	Boundary-scan Test Access Port
+	Temperature diode, anode
-	Temperature diode, cathode
n	No connect

CS144 Pin Function Diagram

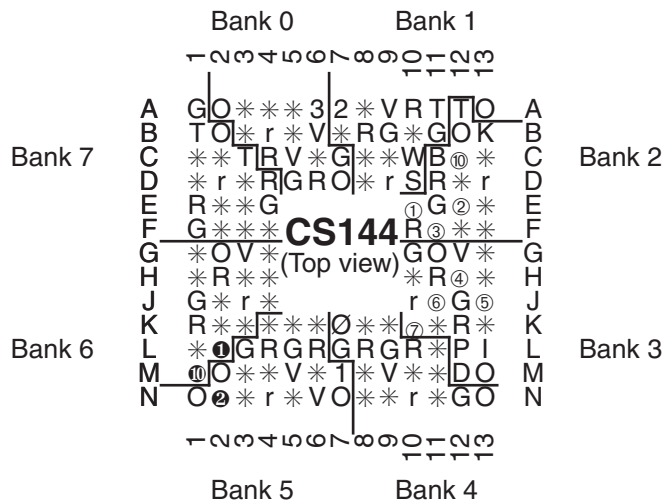

Figure 1: CS144 Pin Function Diagram

TQ144 Pin Function Diagram

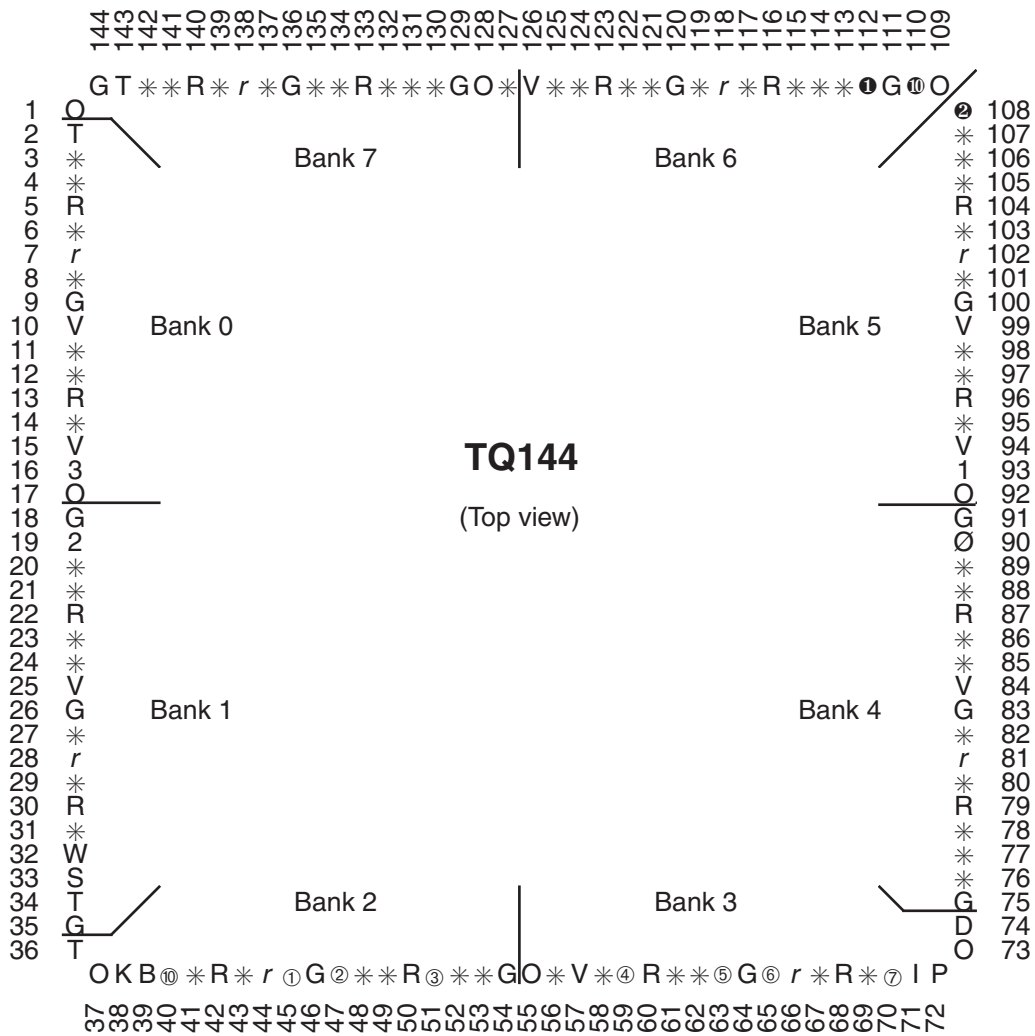

Figure 2: TQ144 Pin Function Diagram

PQ240/HQ240 Pin Function Diagram

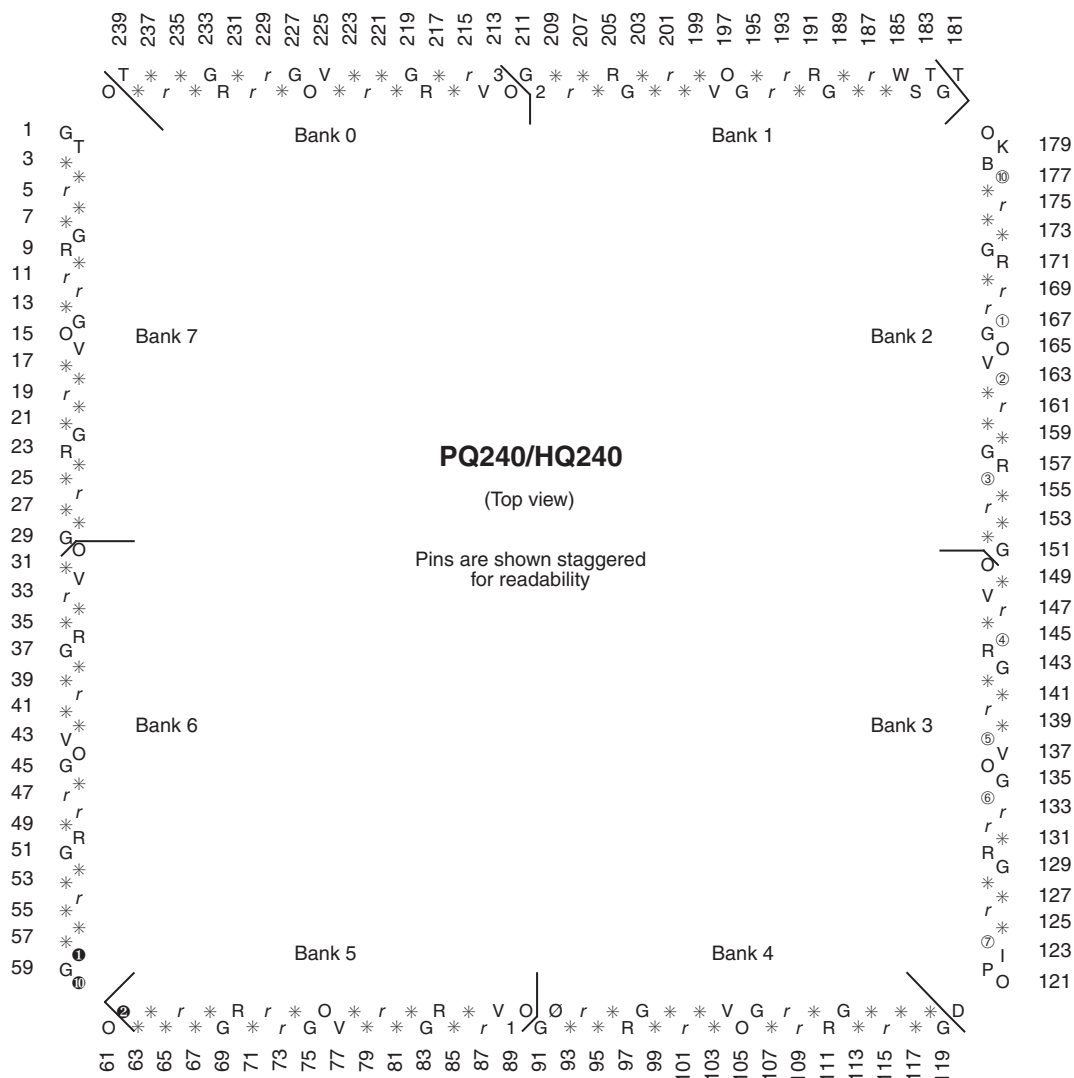
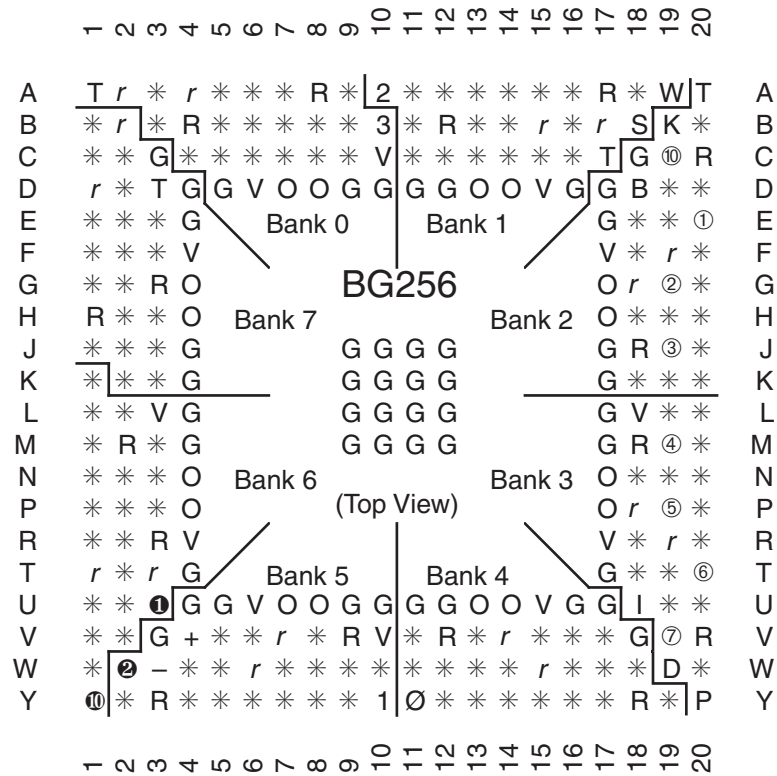

Figure 3: PQ240/HQ240 Pin Function Diagram

BG256 Pin Function Diagram



DS003_18_100300

Figure 4: BG256 Pin Function Diagram

BG352 Pin Function Diagram

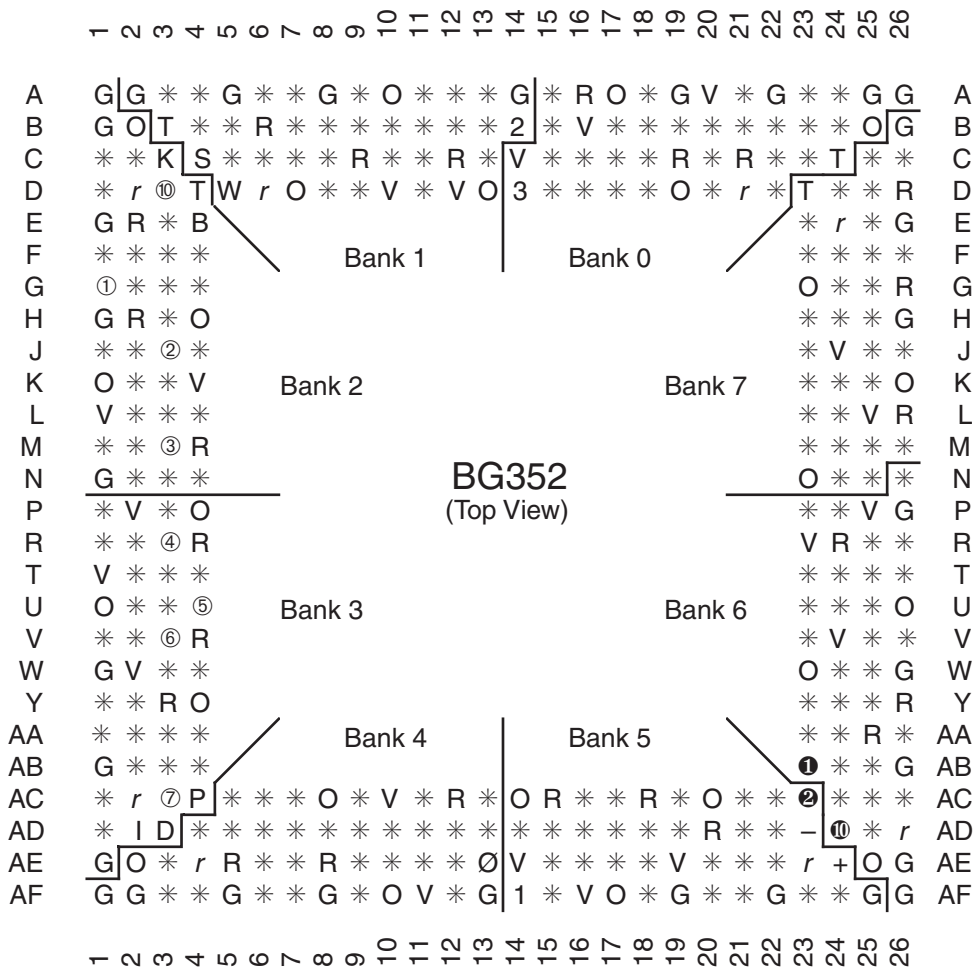

DS003_19_100600

Figure 5: BG352 Pin Function Diagram

BG432 Pin Function Diagram

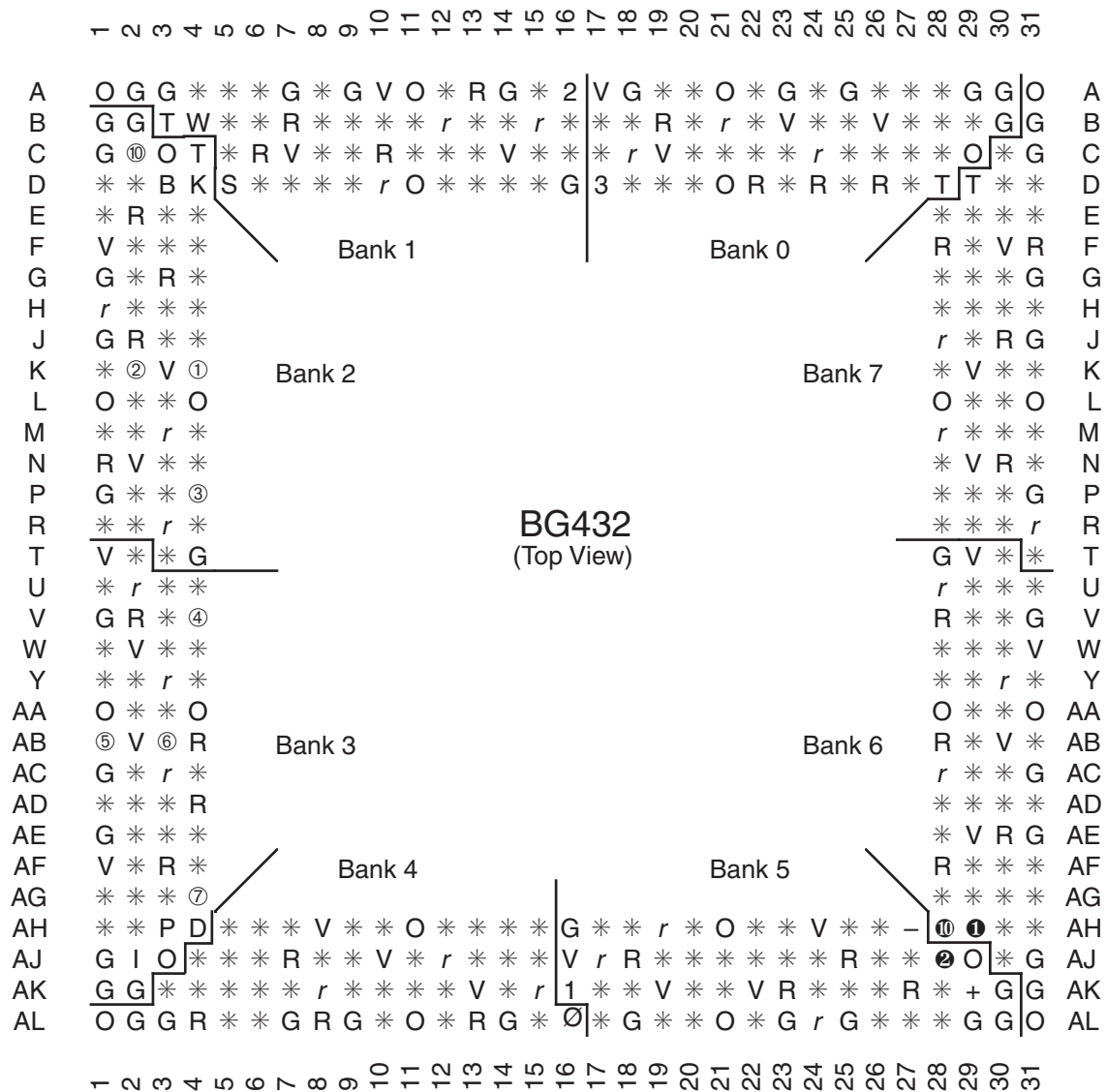

DS003_21_100300

Figure 6: BG432 Pin Function Diagram

FG256 Pin Function Diagram

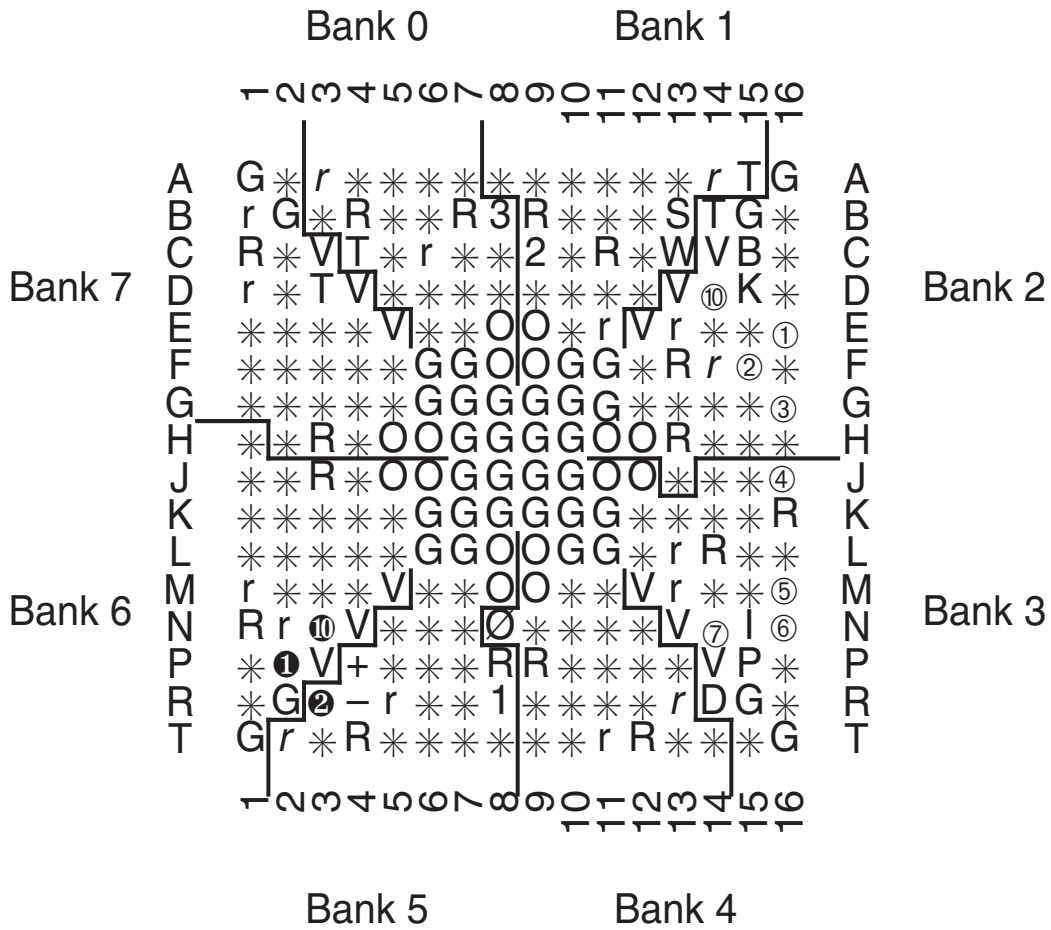

FG256

(Top view)

Figure 8: FG256 Pin Function Diagram

FG456 Pin Function Diagram

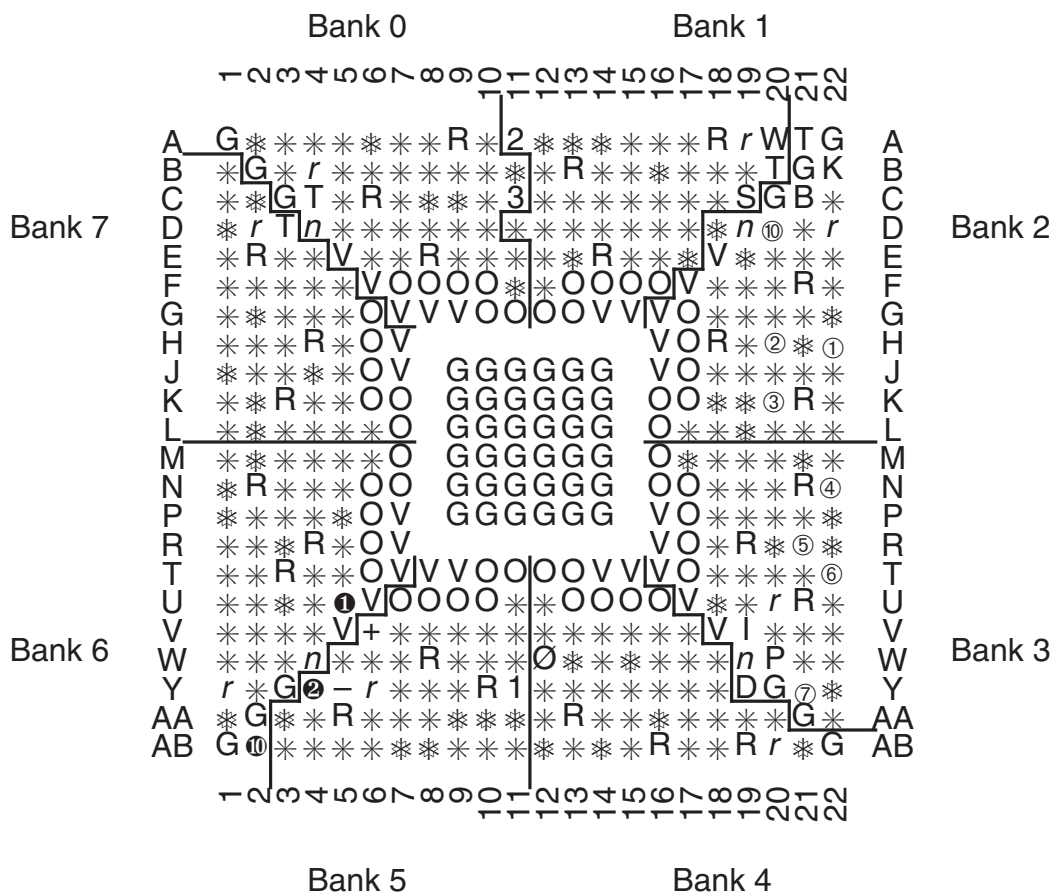

FG456
(Top view)

Figure 9: FG456 Pin Function Diagram

Notes:

Packages FG456 and FG676 are layout compatible.

FG676 Pin Function Diagram

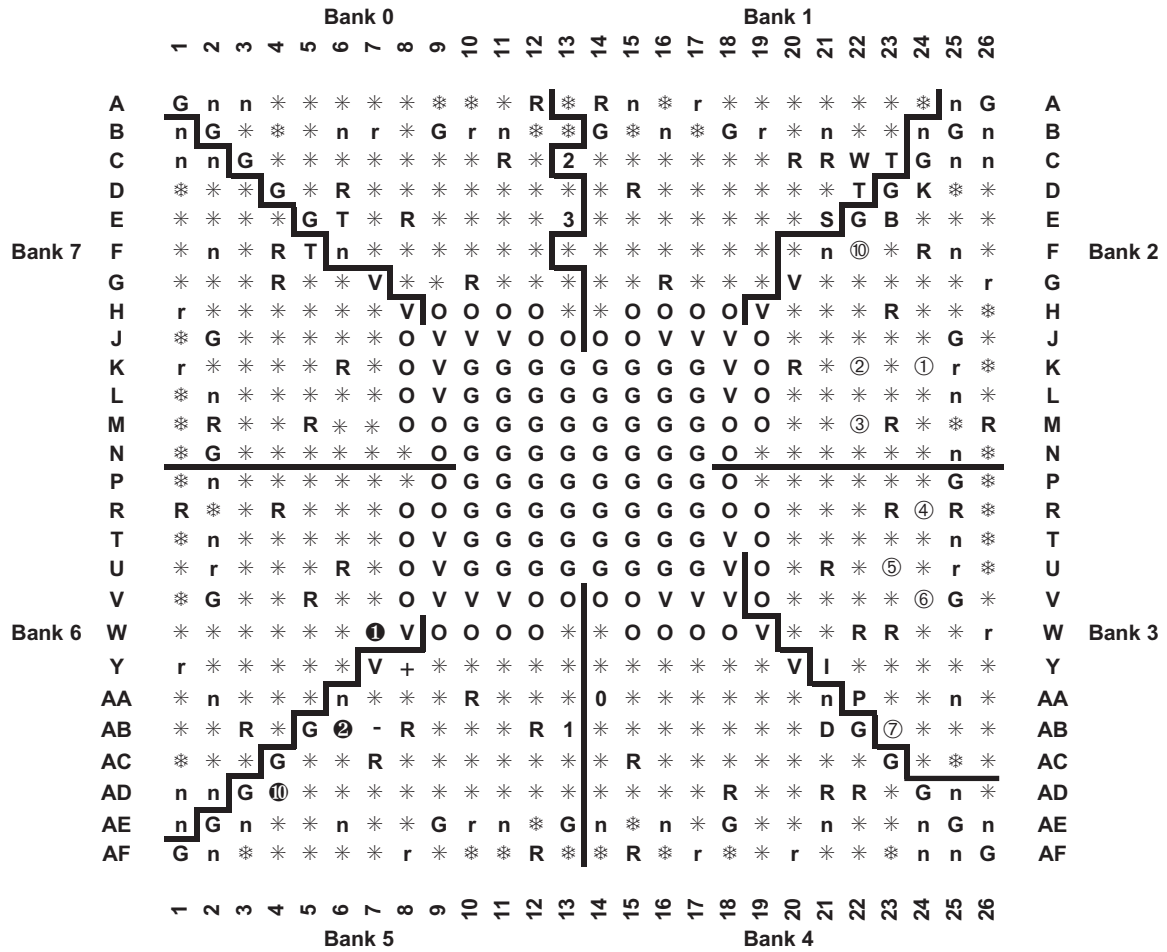

FG676
(Top view)

fg676a

Figure 10: FG676 Pin Function Diagram

Notes:

Packages FG456 and FG676 are layout compatible.

FG680 Pin Function Diagram

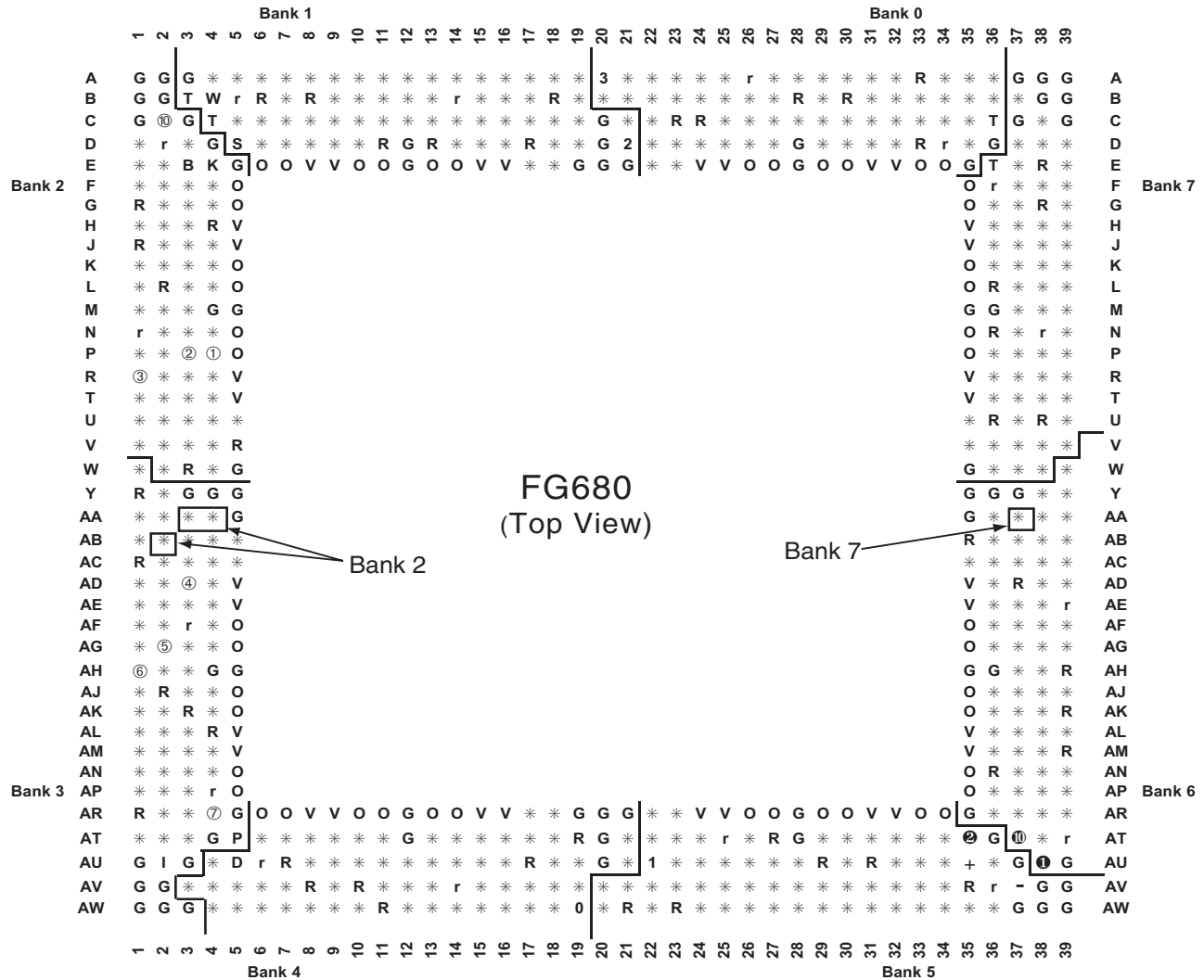

Note: AA3, AA4, and AB2 are in Bank 2

Note: AA37 is in Bank 7

fg680_12a

Figure 11: FG680 Pin Function Diagram

Revision History

Date	Version	Revision
11/98	1.0	Initial Xilinx release.
01/99	1.2	Updated package drawings and specs.
02/99	1.3	Update of package drawings, updated specifications.
05/99	1.4	Addition of package drawings and specifications.
05/99	1.5	Replaced FG 676 & FG680 package drawings.
07/99	1.6	Changed Boundary Scan Information and changed Figure 11, Boundary Scan Bit Sequence. Updated IOB Input & Output delays. Added Capacitance info for different I/O Standards. Added 5 V tolerant information. Added DLL Parameters and waveforms and new Pin-to-pin Input and Output Parameter tables for Global Clock Input to Output and Setup and Hold. Changed Configuration Information including Figures 12, 14, 17 & 19. Added device-dependent listings for quiescent currents ICCINTQ and ICCOQ. Updated IOB Input and Output Delays based on default standard of LVTTTL, 12 mA, Fast Slew Rate. Added IOB Input Switching Characteristics Standard Adjustments.
09/99	1.7	Speed grade update to preliminary status, Power-on specification and Clock-to-Out Minimums additions, "0" hold time listing explanation, quiescent current listing update, and Figure 6 ADDRA input label correction. Added T_{JITCC} parameter, changed T_{OJIT} to T_{OPHASE} .
01/00	1.8	Update to speed.txt file 1.96. Corrections for CRs 111036, 111137, 112697, 115479, 117153, 117154, and 117612. Modified notes for Recommended Operating Conditions (voltage and temperature). Changed Bank information for V_{CCO} in CS144 package on p.43.
01/00	1.9	Updated DLL Jitter Parameter table and waveforms, added Delay Measurement Methodology table for different I/O standards, changed buffered Hex line info and Input/Output Timing measurement notes.
03/00	2.0	New TBCKO values; corrected FG680 package connection drawing; new note about status of CCLK pin after configuration.
05/00	2.1	Modified "Pins not listed ..." statement. Speed grade update to Final status.
05/00	2.2	Modified Table 18.
09/00	2.3	<ul style="list-style-type: none"> Added XCV400 values to table under Minimum Clock-to-Out for Virtex Devices. Corrected Units column in table under IOB Input Switching Characteristics. Added values to table under CLB SelectRAM Switching Characteristics.
10/00	2.4	<ul style="list-style-type: none"> Corrected pinout info for devices in the BG256, BG432, and BG560 pkgs in Table 18. Corrected BG256 Pin Function Diagram.
04/02/01	2.5	<ul style="list-style-type: none"> Revised minimums for Global Clock Set-Up and Hold for LVTTTL Standard, with DLL. Converted file to modularized format. See section Virtex Data Sheet, below.
04/19/01	2.6	<ul style="list-style-type: none"> Corrected pinout information for FG676 device in Table 4. (Added AB22 pin.)
07/19/01	2.7	<ul style="list-style-type: none"> Clarified V_{CCINT} pinout information and added AE19 pin for BG352 devices in Table 3. Changed pinouts listed for BG352 XCV400 devices in banks 0 thru 7.
07/19/02	2.8	<ul style="list-style-type: none"> Changed pinouts listed for GND in TQ144 devices (see Table 2).

Virtex Data Sheet

The Virtex Data Sheet contains the following modules:

- DS003-1, Virtex 2.5V FPGAs:
[Introduction and Ordering Information \(Module 1\)](#)
- DS003-2, Virtex 2.5V FPGAs:
[Functional Description \(Module 2\)](#)
- DS003-3, Virtex 2.5V FPGAs:
[DC and Switching Characteristics \(Module 3\)](#)
- DS003-4, Virtex 2.5V FPGAs:
[Pinout Tables \(Module 4\)](#)