



Xilinx Inc.
 2100 Logic Drive
 San Jose, CA 95124
 Phone: +1 408-559-7778
 Fax: +1 408-559-7114
 E-mail: coregen@xilinx.com
 URL: www.xilinx.com/support/techsup/appinfo
 www.xilinx.com/ipcenter

Features

- Drop-in module for Virtex, Virtex™-E, and Spartan™-II FPGAs
- High-performance 1024-point complex FFT and inverse FFT (IFFT)
- 16-bit complex input and output data
- 2's complement arithmetic
- Flexible I/O and memory interface to Virtex on-chip Block RAM
- High performance and density guaranteed through Relational Placed Macro (RPM) mapping and placement technology
- Incorporates Xilinx Smart-IP technology for maximum performance
- To be used with version 2.1i or later of the Xilinx CORE Generator System

Functional Description

The vFFT1024 fast Fourier transform (FFT) Core computes a 1024-point complex forward FFT or an inverse FFT (IFFT). The input data is a vector of 1024 complex values represented as 16-bit 2's complement numbers – 16-bits for each of the real and imaginary component of a data sample. The 1024 element output vector is also represented using 16 bits for each of the real and imaginary components on an output sample. Three memory and data I/O interfaces are supported. The user interface can be configured to allow the vfft1024 core to simultaneously input new data, transform data stored in memory, and to output previous results.

Theory of Operation

The discrete Fourier transform (DFT) $X(k)$, $k=0,\dots,N-1$ of a sequence $x(n)$, $n=0,1,\dots,N-1$ is defined as

$$X(k) = \sum_{n=0}^{N-1} x(n)e^{-j2\pi nk/N} \quad k = 0, \dots, N-1 \quad (1)$$

where N is the transform size and $j = \sqrt{-1}$. The fast Fourier transform (FFT) is a computationally efficient algorithm for computing a DFT.

The Xilinx 1024-point transform engine employs a Cooley-Tukey radix-4 decimation-in-frequency (DIF) FFT [1] to compute the DFT of a complex sequence. In general, this algorithm requires the calculation of columns or ranks of radix-4 butterflies. These radix-4 butterflies are sometimes referred to as *dragonflies*. Each processing rank consists of $N/4$ dragonflies. For $N=1024$, there are 5 dragonfly ranks, with each rank comprising 256 dragonflies.

The FFT processor input-data for the core is a vector of 1024 complex samples. The real and imaginary components of each sample are represented as 16-bit 2's complement numbers. The data is stored in on-chip dual port Block RAM. The phase factors used in the FFT calculation are generated within the core. Like the input-data, the phase factors are kept to a precision of 16 bits. The complex output samples are also defined with 16 bits of precision for each of the real and imaginary components.

All of the control signals required to interface the FFT module to Block RAM are generated by the core. I/O interface signals are provided to provide a flexible user interface for supplying input vectors and reading FFT result samples.

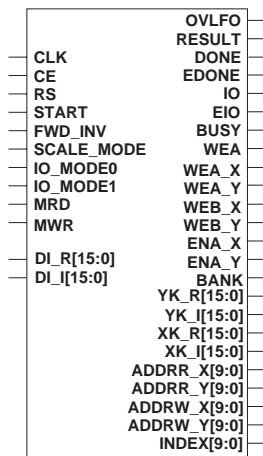

Figure 1: Core Schematic Symbol

Finite Word Length Considerations

The radix-4 FFT algorithm processes an array of data by successive passes over the input data array. On each pass, the algorithm performs dragonflies, each dragonfly picking up four complex numbers and returning four complex numbers to the same addresses. The numbers returned to memory by the processor are potentially larger than the numbers picked from memory. A strategy must be employed to accommodate this dynamic range expansion. A full explanation of scaling strategies and their implications is beyond the scope of this document, the reader is referred to several papers available in the open literature [2] [3] that discuss this topic.

The Xilinx 1024-point FFT Core scales dragonfly results by a factor of 4 on each processing pass. The SCALE_MODE pin can be used to force an additional scaling by one bit on the first processing pass only. The scaling results in the final output sequence being modified by the factor 1/1024 when SCALE_MODE=0 and 1/2048 when SCALE_MODE=1.

The scaling results in the final output sequence being modified by the factor $1/sN$ where $N=1024$ for the vfft1024 core. Formally, the output sequence $X'(k)$, $k=0,1,\dots,N-1$ is computed by the core is defined in the equation below:

$$X'(k) = \frac{1}{sN} X(k) = \frac{1}{sN} \sum_{n=0}^{N-1} x(n) e^{-j2\pi nk/N}$$

$$k = 0, K, \dots, N-1 \quad (2)$$

where $s=1$ when SCALE_MODE=0 and $s=2$ when SCALE_MODE=1. The SCALE_MODE pin can be used for both the forward and inverse FFT modes of operation.

The vfft1024 core also computes the IFFT according to the following defining equation.

$$c(n) = \frac{1}{sN} \sum_{k=0}^{N-1} X(k) e^{j2\pi nk/N} \quad n = 0, 1, K, \dots, N-1 \quad (3)$$

The built-in scaling in the core accounts for the $1/N$ scale factor in front of the summation in Eq. (3). When SCALE_MODE=1, an additional scaling by a factor of 1/2 will be scheduled in the core. The additional scaling by 1 bit is inserted during the memory write operation during the first of the 5 processing phases.

Pinout

Core signal names are shown in Figure 1 and the signals are described in Table 1.

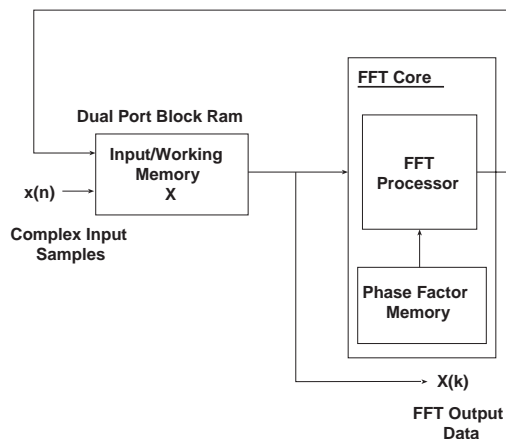

Figure 2: Abstract Model of the SMS FFT Core Interface

Table 1: Core Signal Pinout

Signal Name	Signal Direction	Description
CLK	Input	Master clock (Active rising edge)
CE	Input	Clock enable (Active High)
RS	Input	Reset (Active High)
START	Input	Start processing (active high). This signal must be synchronized with CLK.
FWD_INV	Input	Defines if a forward (FWD_INV=1) or inverse (FWD_INV=0) FFT is performed. This signal is sampled when START is asserted for all memory configuration options (SMS, DMS, and TMS). When the DMS and TMS configurations are selected, where FFTs are computed continuously, FWD_INV is sampled when MODE_CE is asserted by the core. This permits alternating forward and inverse FFTs to be performed.
SCALE_MODE	Input	FFT scaling control. When SCALE_MODE=0 the FFT output vector is scaled by 1/1024. When SCALE_MODE=1 the FFT output vector is scaled by 1/2048. This signal is sampled when START is asserted for all memory configuration options (SMS, DMS, and TMS). When the DMS and TMS configurations options are selected, where FFTs are computed continuously, SCALE_MODE is sampled when MODE_CE is asserted by the core. This permits different scaling options to be used for successive FFTs without any interruption to processing.
IO_MODE0	Input	Together with the IO_MODE1 pin, these signals define the type of memory interface to be used, single, dual or triple memory space configurations. The memory configurations also effectively define the method by which data is presented to the core and read back from the core. The precise functionality of IO_MODE0 and IO_MODE1 are defined in the I/O Interface and Memory Configurations section of this document.
IO_MODE1	Input	I/O interface and memory configuration select pin – refer to the signal description for IO-MODE0 for details.
MRD	Input	Result vector read strobe (Active High). This signal must be synchronized with CLK.
MWR	Input	Input data write strobe (Active High). This signal must be synchronized with CLK.
DI_R[15:0]	Input	Input data bus – real component. The real component of the input data vector is presented to the core on this port. Two's complement data format is assumed.
DI_I[15:0]	Input	Input data bus –imaginary component. The imaginary component of the input data vector is presented to the core on this port. Two's complement data format is assumed.
OVFLO	Output	Active high Arithmetic overflow indicator. Even when employing a 2-bit scale factor for each FFT processing phase, certain input signals can cause arithmetic overflow. This pin indicates that an internal arithmetic overflow has been generated. When additional scaling is employed by setting SCALE_MODE=1, there is no possibility of overflow occurring and this signal will not be active. OVFLO is removed when the core is reset by asserting RS, when START is asserted, or at the beginning of the next output result vector as indicated by DONE.
RESULT	Output	FFT result strobe (Active High). This signal indicates that a new (I)FFT result vector is available. It frames the YK_R and YK_I output buses.
DONE	Output	FFT complete strobe (Active High). DONE will transition high for one clock cycle at the end of the RESULT strobe.
EDONE	Output	Early done strobe (Active High) EDONE goes high for one clock cycle immediately prior to RESULT going active.
IO	Output	IO cycle strobe. (Active High) This signal is only intended to be used with the dual-memory-space core configuration.

Table 1: Core Signal Pinout

Signal Name	Signal Direction	Description
EIO	Output	Early I/O strobe. (Active High) This signal is only intended to be used with the dual-memory-space core configuration.
BUSY	Output	Core activity indicator (Active High). This signal will go high in response to the start signal and will remain high while the core is processing data.
WEA	Output	Block RAM port A write enable strobe (active high). This write signal is used for the single-memory-space configuration.
WEA_X	Output	Block RAM port A write enable strobe (Active High). This write signal is used for the dual- and triple-memory-space configurations.
WEA_Y	Output	Block RAM port A write enable strobe (Active High). This write signal is used for the dual and triple memory space configurations.
WEB_X	Output	Block RAM port B write enable strobe (Active High). This write signal is used for the dual- and triple-memory-space configurations.
WEB_Y	Output	Block RAM port B write enable strobe (Active High). This write signal is used for the dual and triple memory space configurations.
ENA_X	Output	Block RAM port A enable signal (Active High). This memory enable signal is used for the single, dual and triple-memory- space configuration options.
ENA_Y	Output	Block RAM port A enable signal (Active High). This memory enable signal is used for the triple-memory-space configuration option.
BANK	Output	Memory bank select signal to be used with the triple- memory-space core configuration.
XK_R[15:0]	Output	FFT result bus – real component. The real component of the FFT result vector is presented on this bus. The values are in two's complement format.
XK_I[15:0]	Output	FFT result bus –imaginary component. The imaginary component of the FFT result vector is presented on this bus. The values are in two's complement format.
YK_R[15:0]	Output	FFT result bus – real component. The real component of the FFT result vector is presented on this bus. This output bus is intended to be used for the dual and triple memory space configurations. The values are in two's complement format.
YK_I[15:0]	Output	FFT result bus –imaginary component. The imaginary component of the FFT result vector is presented on this bus. This output bus is intended to be used for the dual and triple memory space configurations. The values are in two's complement format.
ADDRR_X[7:0]	Output	Block RAM read address bus used for the single, dual and triple memory configurations.
ADDRR_Y[7:0]	Output	Block RAM read address bus used for the dual and triple memory configurations.
ADDRW_X[7:0]	Output	Block RAM write address bus used for the single, dual and triple memory configurations.
ADDRW_Y[7:0]	Output	Block RAM write address bus used for the dual and triple memory configurations.

Data Load Phase

A data load operation is initiated by asserting the MWR signal for one clock period as shown in Figure 4. The host system supplies input samples on the XN_[R/I] buses on successive clock cycles. The data is written into memory on the rising edge of the clock. The MWR signal causes the FFT core to generate the memory address and control signals.

Compute Phase

Asserting MWR only initiates a data load operation, at the completion of the data load phase no further activity will ensue until the FFT engine is started by asserting the START signal. The timing for START is shown in Figure 5.

For all of the modes, SMS, DMS, and TMS, the operating mode input signals, FWD_INV and SCALE_MODE are sampled on the rising edge of CLK with START used internally within the core as a qualifier (clock enable). The FWD_INV and SCALE_MODE function signals are sampled on the rising edge of CLK with START used as a qualifier.

Result Unload Phase

Once the FFT is completed the result data is stored in the input memory bank – in fact the only memory bank in this configuration. The data is stored in digit reversed order [1]. The data is read back from memory by initiating a data read operation. The read operation unscrambles the data so that it is presented to the host system in natural order. A read operation is started by asserting MRD high for one clock period as shown in Figure 7. The FFT result vector is presented on Port B of the Block RAM.

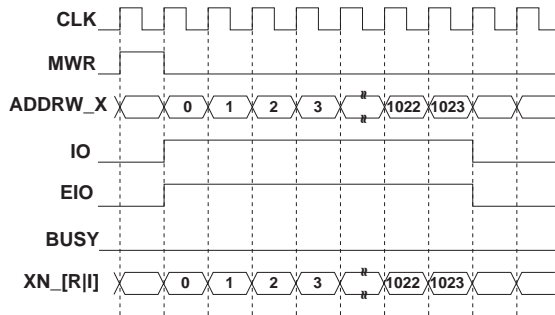

Figure 4: SMS Configuration Input Data Load Timing

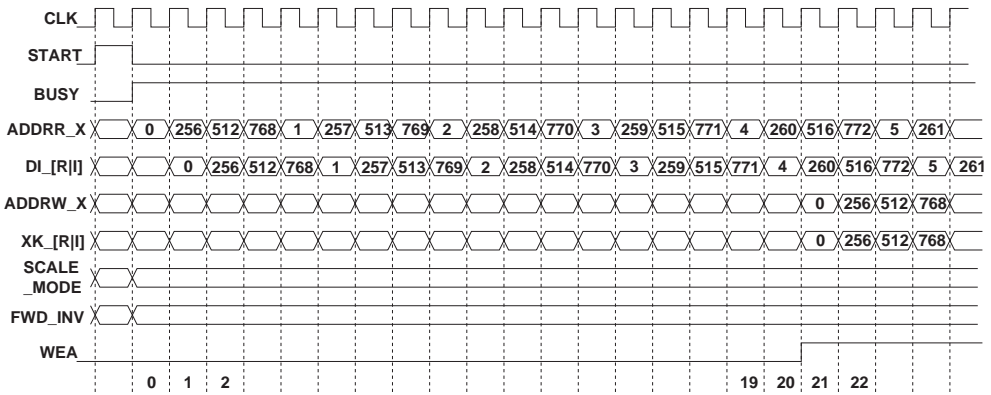

Figure 5: SMS configuration FFT Start Timing

Performance SMS Configuration

Three factors contribute to the FFT core performance in a system: 1) the input vector load time, 2) FFT computation time, and 3) the result unload time. The input load and result unload operations each require 1024 clock cycles. For example, using a 100 MHz system clock, both operations require 10.24 microseconds each.

The first FFT output sample is written to memory 3121 clock cycles after START is asserted. The final sample is written to memory 4145 clock cycles following START. The computation phase alone is 41.45 microseconds in duration. Using an 80 MHz clock the execution time is 51.81 microseconds.

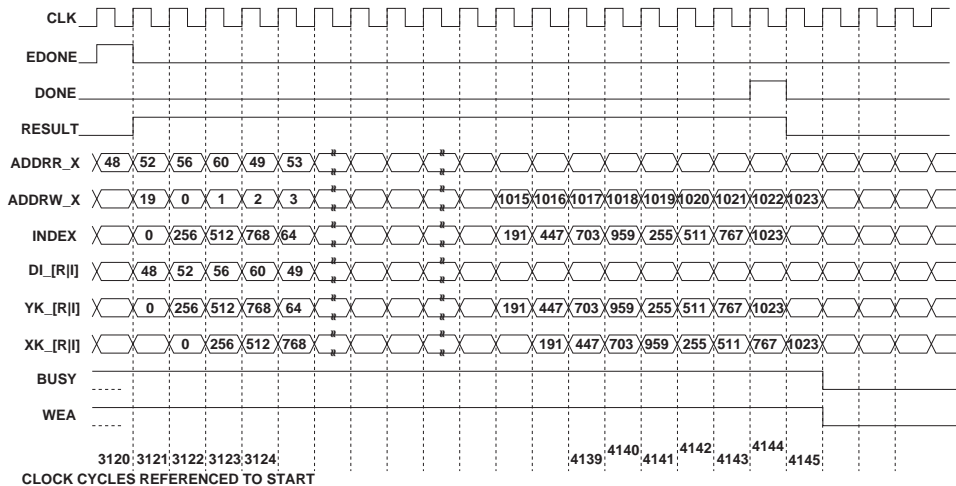

Figure 6: SMS Configuration Result Timing

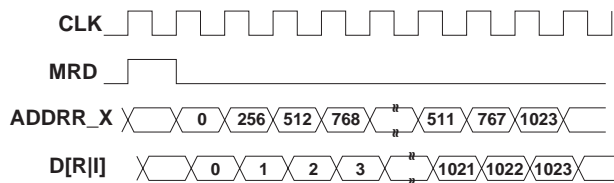

Figure 7: SMS Configuration Result Read Timing

Dual-Memory-Space (DMS) Configuration

The dual memory configuration shown in Figure 8 allows input, computation and output operations to be overlapped, so that the FFT core is never left in an idle state waiting for a host I/O operation. To understand how this mode works recall that an FFT is computed by making multiple processing passes over the input data. For the case of a 1024-point FFT, five such radix-4 computation stages are required. During the final processing phase in the DMS configuration, instead of returning the processed data to the input/working buffer X, it is stored in the output memory bank Y. Concurrent with this operation, a new vector of input data is written into memory bank X. Therefore, data load, computation and output operations are overlapped, and no computation cycles are wasted due to I/O cycles. The new data must be burst into memory because only 1024 clock cycles are available in which to perform the operation. The burst I/O operation must be synchronized with the FFT engine. Several control signals are generated by the core to facilitate this operation. When the FFT output vector has been placed in the output buffer, the host system can use the second port of the dual port Block RAM to read back the result and pass this data to down-stream components in the system.

Because the FFT is effectively being performed out-of-place (in contrast to the in-place process of the SMS configuration), the result vector can be written to the output buffer memory Y in natural order. An address indexing bus (INDEX) is supplied for this purpose. The host system should therefore treat the output samples in memory space Y as a naturally ordered FFT result vector.

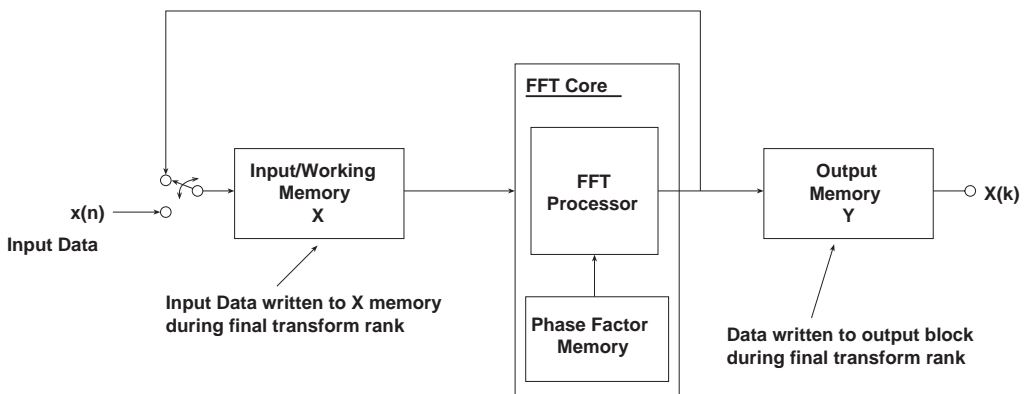

Figure 8: DMS FFT Core Interface

The detailed schematic for the DMS FFT configuration is shown in Figure 9. The host system must supply a multiplexor to share port A of the dual port Block RAM between the input samples $XN_{[R/I]}$ and the FFT result bus $XK_{[R/I]}$. A multiplexor control signal (IO) is generated by the core to make this interface simple to implement. Even though only one port of the memory is used for writing, due to the concurrent read and write operations, a dual port memory must be used. Because of certain timing events in the core, it is not possible to use the port B input databus – it should be tied to a suitable inactive state.

The RESULT strobe indicates that a new result vector is appearing on the $YK_{[R/I]}$ buses. The strobe exactly frames the vector and can be used as a write enable signal for memory bank Y. The FFT samples appearing on the $YK_{[R/I]}$ bus are presented in digit (radix-4) permuted order. The INDEX bus can be used to perform data re-ordering as the results are written to memory.

This mode of operation would typically be used by first performing a data load operation – exactly like the memory write operation described for the SMS configuration. After the initial data load has completed, the FFT engine is started by asserting START synchronously with CLK. START is only employed in this mode for starting the very first transform of a sequence of FFTs – IT SHOULD NEVER BE ASSERTED AGAIN UNLESS THE INTENTION IS TO RE-START THE ENTIRE PROCESSING ENGINE.

The FWD_INV and SCALE_MODE pins are sampled when START is applied. Once the core has entered its computation phase, the FFTs are being performed back-to-back, FWD_INV and SCALE_MODE will be sampled when MODE_CE is asserted.

Once started, the core will continue processing input vectors in an uninterrupted manner. This does not imply that data can be continuously streamed into memory, memory write operations must be synchronised with the core using the IO and/or the EIO signals. Observe that the I/O operations and processing are overlapped, unlike the SMS FFT architecture.

Figure 10 provides timing information for the output result and I/O operations. The IO signal exactly frames a user data load operation. EIO is an early I/O strobe that is provided as a pre-emptive signal to indicate to the data source that a load operation is about to be initiated.

Figure 11 provides timing details for the completion phases of a data load operation. This figure also shows the timing for the MODE_CE signal. This signal indicates when the operation mode pins FWD_INV and SCALE_MODE are sampled. Using this signal, alternating forward and inverse FFTs can be computed. In addition, the scaling mode may be changed between successive computations. The FWD_INV and SCALE_MODE signals need only be valid during the single clock period indicated by MODE_CE. At other times the system is free to change the state of these signals – of course this will have no impact on the processing currently in progress.

Performance DMS Configuration

After the initial memory load operation, a new result vector will be available every 4096 clock cycles.

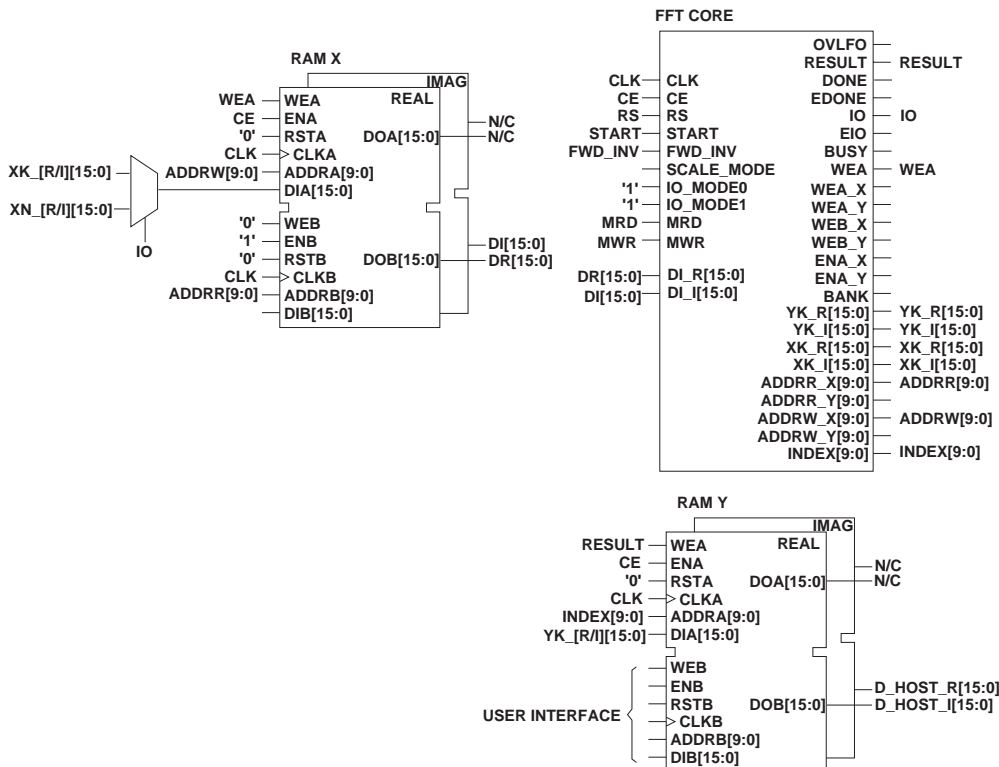

Figure 9: DMS Core Configuration Detailed Connection Diagram

Triple-Memory-Space (TMS) Configuration

While the DMS configuration ensures that the FFT core is supplied with data 100% of time so that no potential computation cycles are wasted, it requires the user to burst data into the input memory bank synchronously with the core operation. The I/O requirements can be relaxed with the TMS configuration. This model of computation is shown conceptually in Figure 12. There are two input/working memory banks, designated X and Y respectively, and one output buffer Z. While the FFT core is working with one memory bank, say X, the host system can load data into the alternate memory bank, Y in this case.

The result vector is always written to buffer Z. The host system has complete access to the input memory that is not currently involved in the calculation, and so has more flexibility, compared to the DMS configuration, over the way in which a new input vector is written to memory. For the case of a 1024-point FFT an average of 4 clock cycles are available for writing each new input sample to memory. When the FFT core has finished processing the current input data, the memory banks are swapped and the data load and computation continues on the alternate memory buffer. This type of processing is often referred to as a pingpong mode of memory architecture.

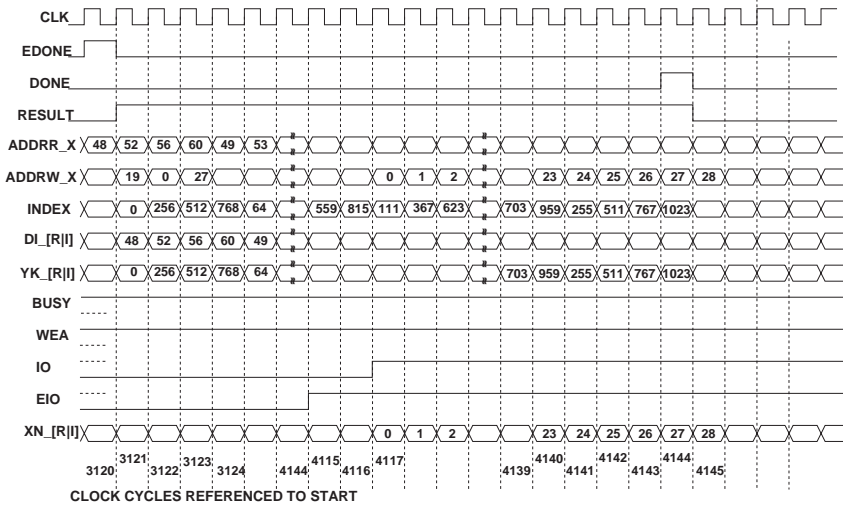

Figure 10: DMS Configuration Result and I/O Timing

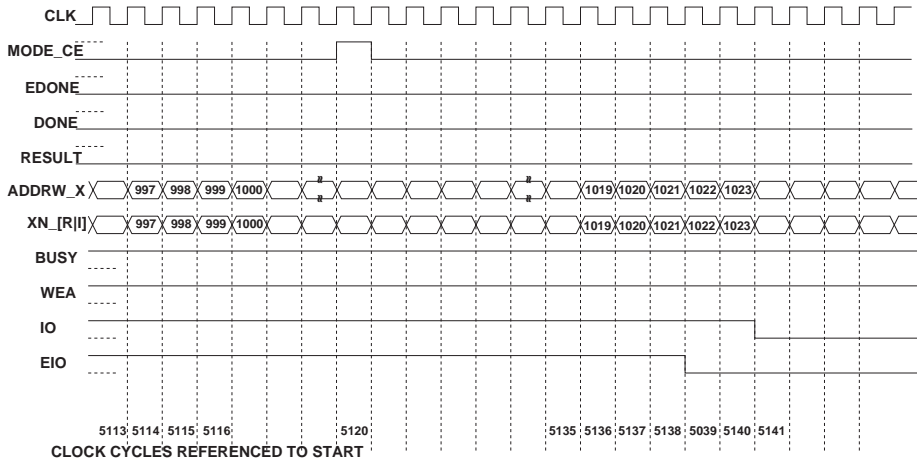

Figure 11: DMS Configuration Timing Showing Completion of a Data Load Operation

The output result is written to bank Z in much the same manner as for the DMS configuration. Again, the FFT output samples are presented on the result bus in digit-reversed order and can be re-ordered as they are written to

memory. The FFT core can use one port of dual-port RAM for writing and the host can use the other port for unloading the result once the write operation has completed.

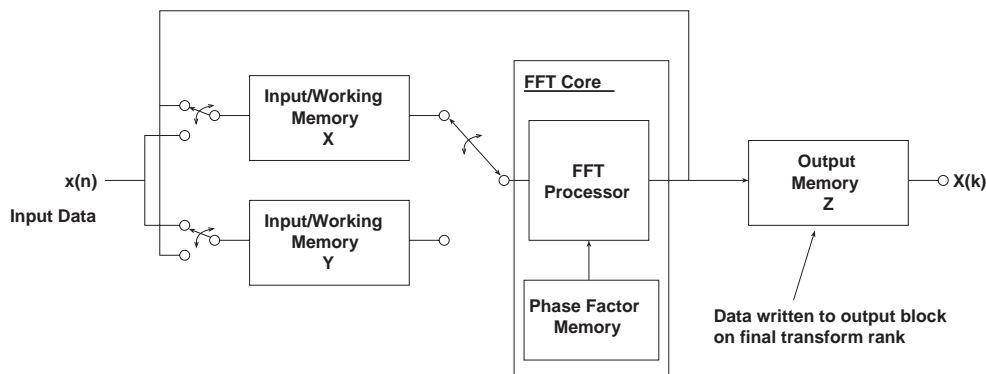

Figure 12: Abstract Model of the TMS FFT Core Interface

As with the DMS configuration, I/O operations are completely overlapped with the FFT computation. However, unlike that mode, the new input samples can be presented to the input buffer in a continuous, rather than as a burst operation. A new sample is written to memory every 4 clock cycles. All of the memory interface signals are generated by the core to simplify system integration.

It may be tempting to start the unload operation prior to completion of the vector write operation since two independent memory interfaces are available on the output buffer. However, remember that the results are not written to memory in linear order but in digit-reversed order, and so it is recommended that the host system stall any memory activities until the result write operation has completed.

The FWD/INV and SCALE/MODE pins are sampled when START is applied. Once the core has entered its computation phase, and FFTs are being performed back-to-back, FWD/INV and SCALE/MODE will be sampled when MODE_CE is asserted.

A detailed interconnection diagram for the TMS configuration is provided in Figure 13. In addition to the three complex 1024 x 16 memory buffers (6 Virtex Block RAMs in total), the design requires a simple 2-to-1 16-bit multiplexor. To simplify the timing of the interface the FFT core provides a multiplexor control signal – BANK. This architecture can support a continuous stream of samples, a new sample being presented to the system every 3 clock cycles.

This mode of operation would typically be used by first loading memory bank X using a similar procedure for the data load operation in the SMS configuration. The timing for the memory write operation is shown in Figure 14. The FFT engine would then be activated by asserting START for a single period of CLK as shown in Figure 15. This figure also illustrates the timing for BANK and the memory interface signals WEA_X, WEA_Y, WEB_X, WEB_Y, ENA_YX, and ENA_Y.

The MODE_CE output signal provides the same functionality in this configuration as in the DMS mode of operation. Using MODE_CE, the host system may perform alternating forward and inverse FFTs, in addition to changing how scaling is handled between successive input vectors.

Figure 16 shows the FFT output timing. The address bus INDEX can be used to unscramble the data as it appears on the core result bus YK_[R/I]. The RESULT strobe indicates when valid data is available on the FFT output bus.

Performance TMS Configuration

After the initial memory load operation, a new transform result is available every 4096 clock cycles.

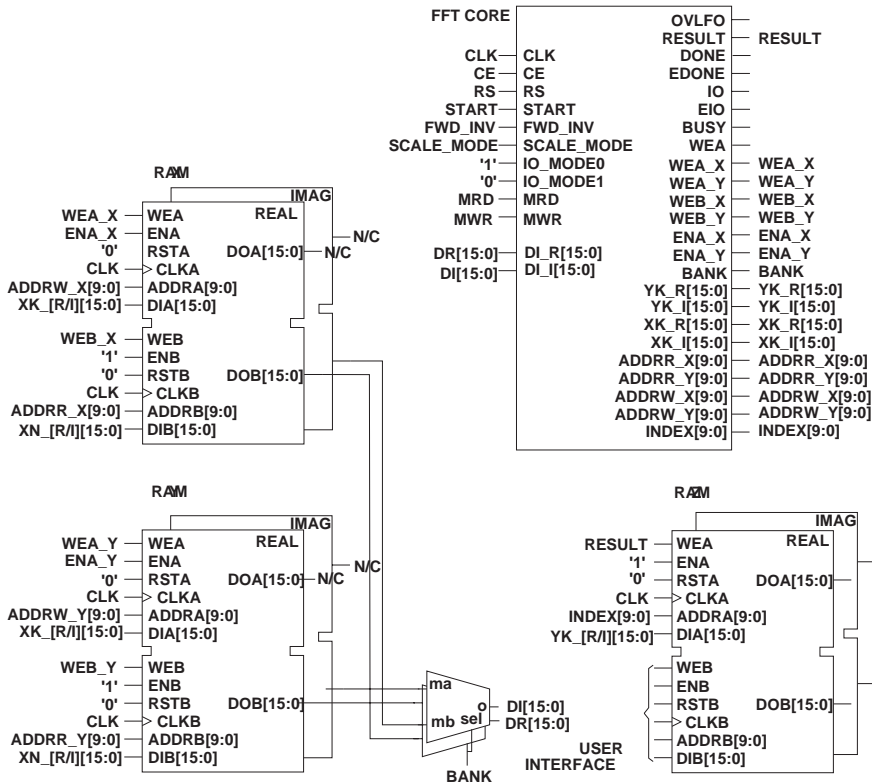

Figure 13:

Core Resource Utilization

The 1024-point FFT Core occupies 1929 logic slices. The geometry of the RPM requires it to be placed in a XCV300 or larger device.

Behavioral Simulation

Release Version 1.0 of the `vfft1024` core has VHDL behavioral model, but does not include a verilog behavioral model.

Implementation

The `vfft64` core is supplied as a group of edif netlists. The top level netlist is called `vfft64.edn`. All of the netlists that are delivered with the core must be present in the user's project directory. The edif netlists are:

```
vfft64.edn
xdsp_cnt6.edn
xdsp_cnt9.edn
xdsp_cos64.edn
xdsp_mul16x17z4.edn
```

```
xdsp_mux2w1.edn
xdsp_mux2w16.edn
xdsp_mux2w4.edn
xdsp_mux3w1.edn
xdsp_mux4w16.edn
xdsp_radd16.edn
xdsp_radd17.edn
xdsp_ramd16a4.edn
xdsp_reg15.edn
xdsp_reg16.edn
xdsp_reg16b.edn
xdsp_reg16l.edn
xdsp_rsub16.edn
xdsp_rsub16b.edn
xdsp_rsub17.edn
xdsp_rsub17b.edn
xdsp_sin64.edn
xdsp_tcompw16.edn
xdsp_tcompw16b.edn
xdsp_tcompw17.edn
```

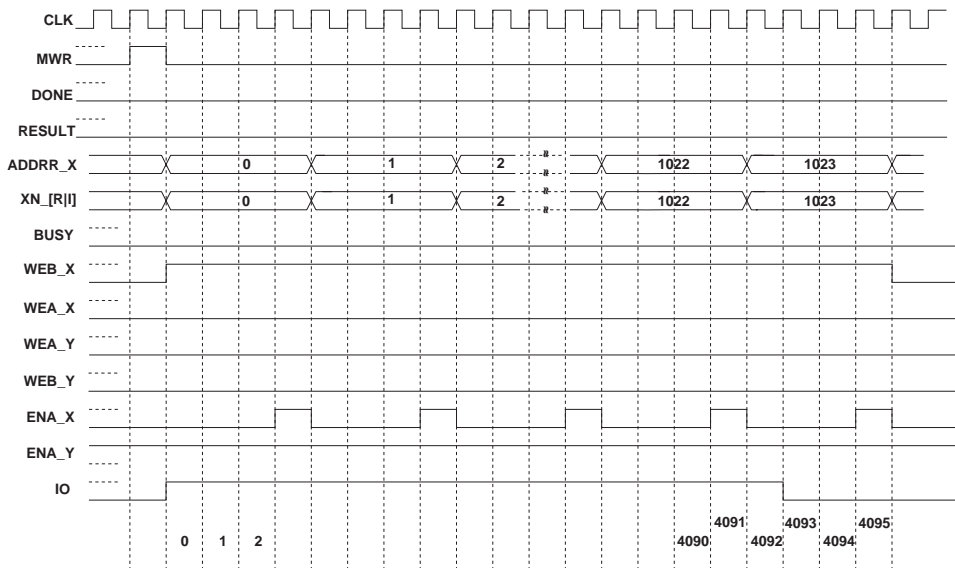

Figure 14:

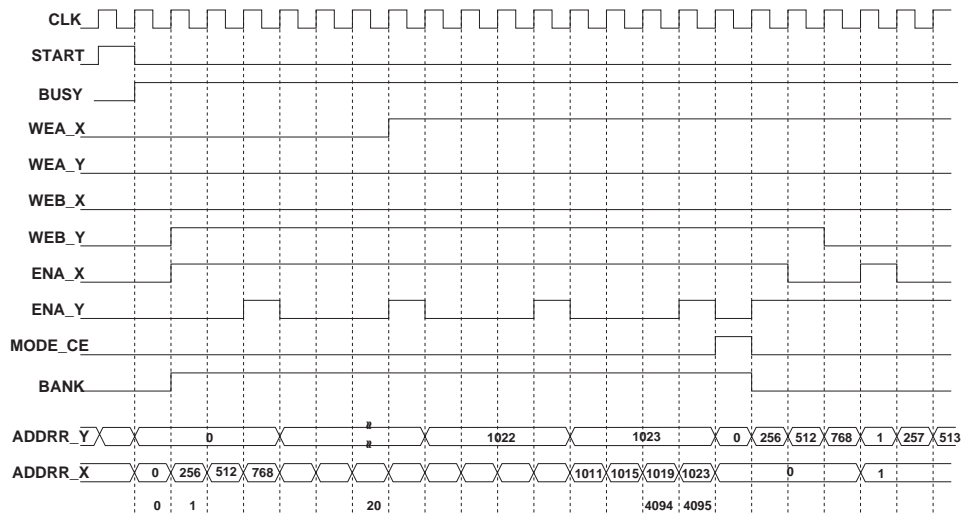

Figure 15:

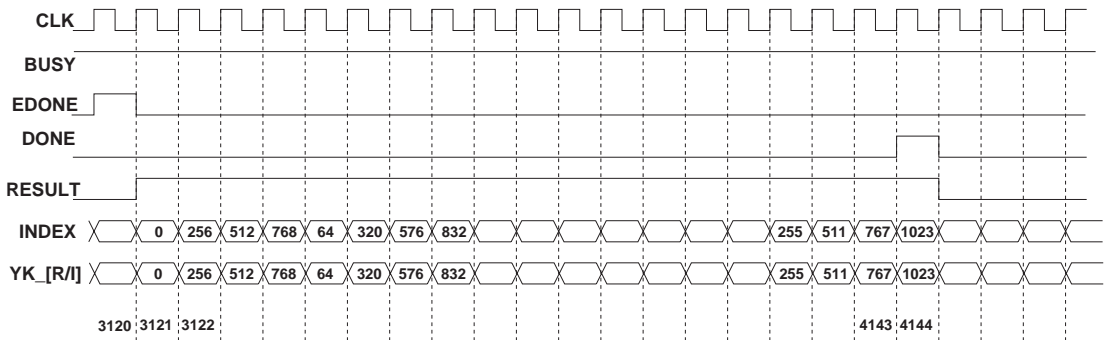

Figure 16: TMS Core Configuration Result and INDEX Address Bus Timing

Ordering Information

This core is downloadable free of charge from the Xilinx IP Center (www.xilinx.com/ipcenter), for use with version 2.1i or later of the Xilinx CORE Generator System. The CORE Generator System 2.1i tool is bundled with the Alliance 2.1i and Foundation 2.1i implementation tools.

To order Xilinx software contact your local Xilinx sales representative at www.xilinx.com/company/sales.htm.

References

- [1] J. W. Cooley and J. W. Tukey, "An Algorithm for the Machine Calculation of Complex Fourier Series", *Math. Comput.*, Vol. 10, pp. 297-301, April 1965.
- [2] W. R. Knight and R. Kaiser, "A Simple Fixed-Point Error Bound for the Fast Fourier Transform", *IEEE Trans. Acoustics, Speech and Signal Proc.*, Vol. 27, No. 6, pp. 615-620, Dec. 1979.
- [3] L. R. Rabiner and B. Gold, *Theory and Application of Digital Signal Processing*, Prentice-Hall Inc., Englewood Cliffs, New Jersey, 1975.
- [4] The Mathworks Inc., *Matlab User's Guide*, Boston Mass., USA, 1999.