

# Accessing the Network

---

**George Abou-Arrage**

**Assistant Vice-President, Magellan Access**



# Agenda

---

- **Network Access Models**
- Telefonica Presentation
- CIBC Presentation
- Magellan Access Vision and Solutions

# Typical Network Model

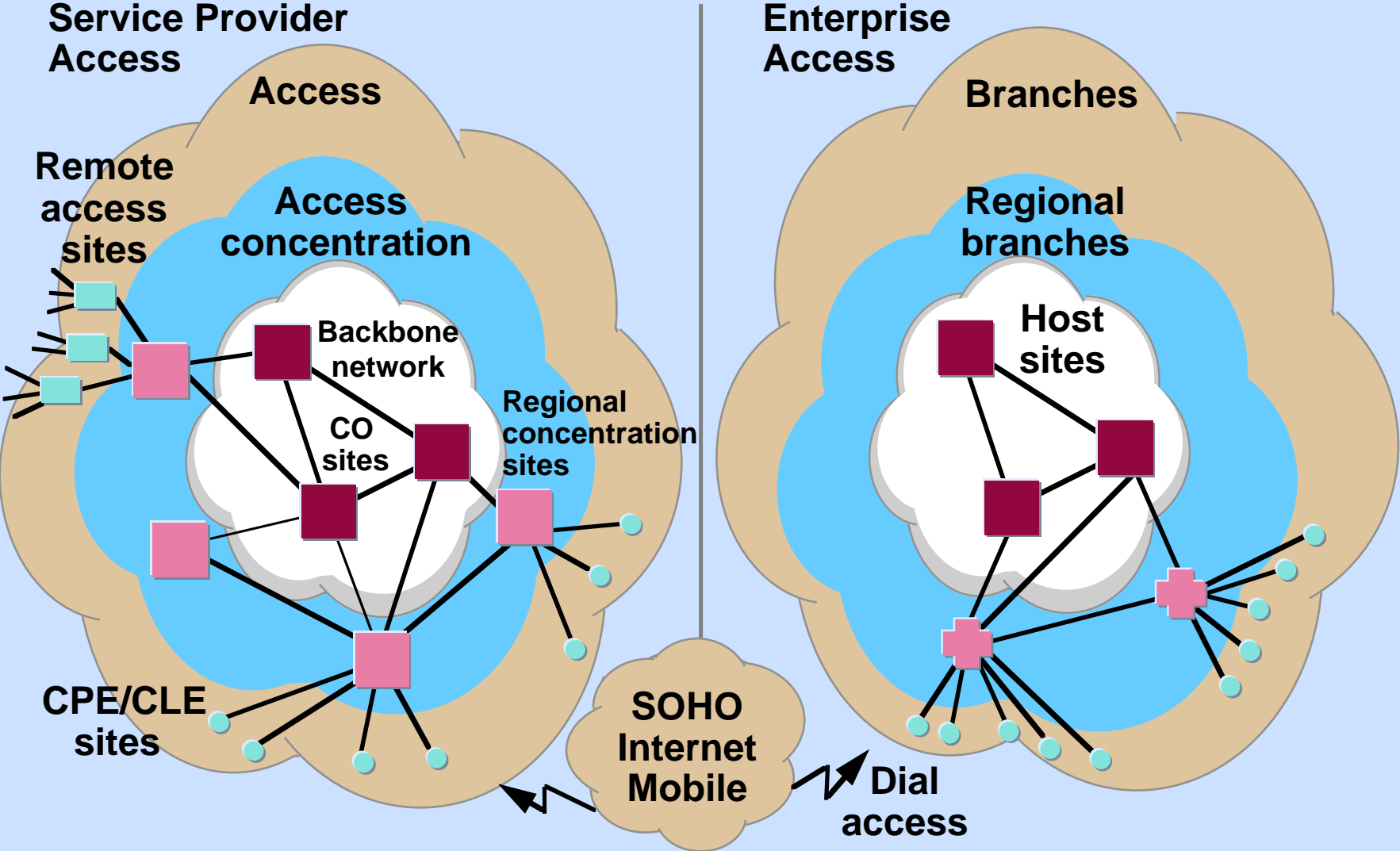

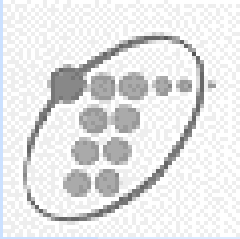

# Telefónica Transmisión de Datos

---

**Mr. David Moulet**

**Director of Marketing**

**Telefónica Transmisión de Datos**



# Telefónica Transmisión de Datos

David Moulet, Marketing Director

Inform 96

# Agenda

- **Public Data Networking in Spain**
- **Current Environment**
- **Moving Forward**
- **New Services**
- **Managing the Business**
- **Access**
- **Summary**



# Public Data Networking in Spain

- **1971 IBERPAC Data Network Launched**
  - Telefónica pioneered public data networks
- **1992 Nortel Technology Introduced**
  - Reliability
  - Centralized management
  - New VPN services
- **1996 Telefónica Transmisión de Datos sold to Unisource**
  - Nortel becomes common denominator
  - Seamless across Europe



# Current Environment

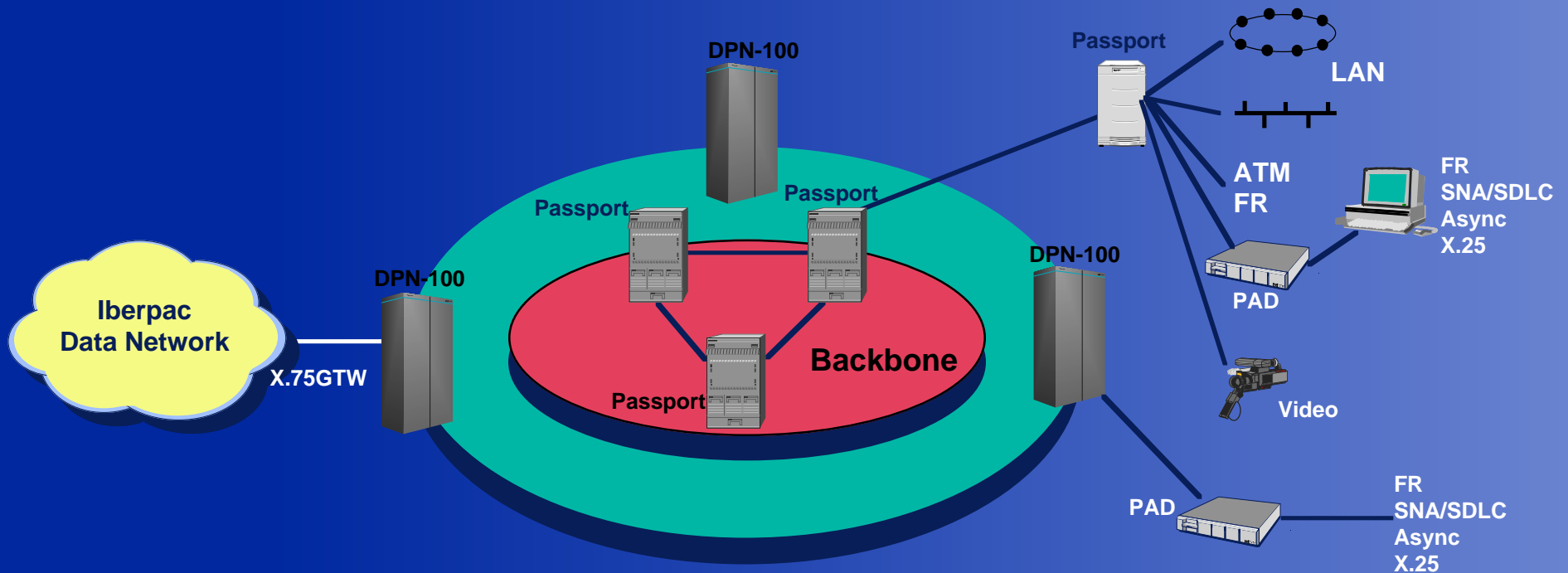

## RED UNO

- **RED UNO**

- DPN-100 and Passport
- X.25, X.75, Frame Relay, ISDN X.31, SNA/SDLC, X.28
- 34,000 ports (930 FR)
- 300 Customers

- **IBERPAC**

- 52,000 ports (X.25, X.28, X.32)
- 3,500 Customers





# Moving Forward

- **Passport Deployment**

- Growing Demand in High Speed Access  
Frame Relay ports will triple in 96
- New Services  
Consolidated Voice and Data  
Video in Corporate Networks  
ATM

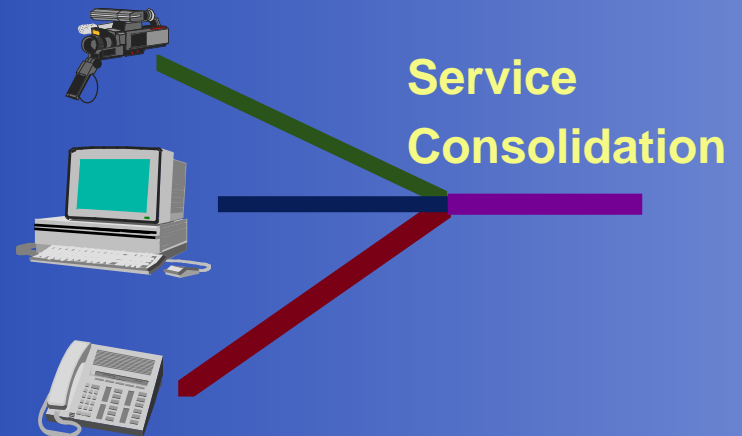

- **New Clients**



Government



Internet Access Providers



# New Services

- **CINCO Service**

- Strategic integrated network service
- Medium-large corporations / sites
- Voice/Data/Video over Passport

- **INTERVOZ Service**

- Basic offering (economy over quality)
- Small companies / sites
- Based on FRADs as transitional technology, evolving to “Oscar” in 1997

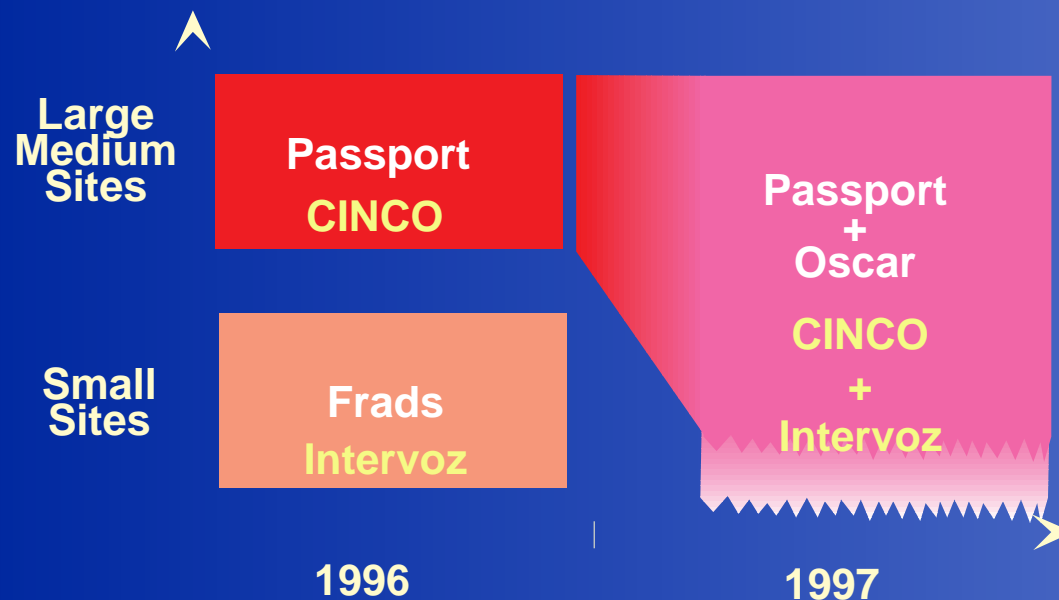

# Managing the Business

- Sophisticated management capabilities becoming a key differentiator
- Customer Network management must meet customer expectations

## Customer VPN Management

## Internal Network Management

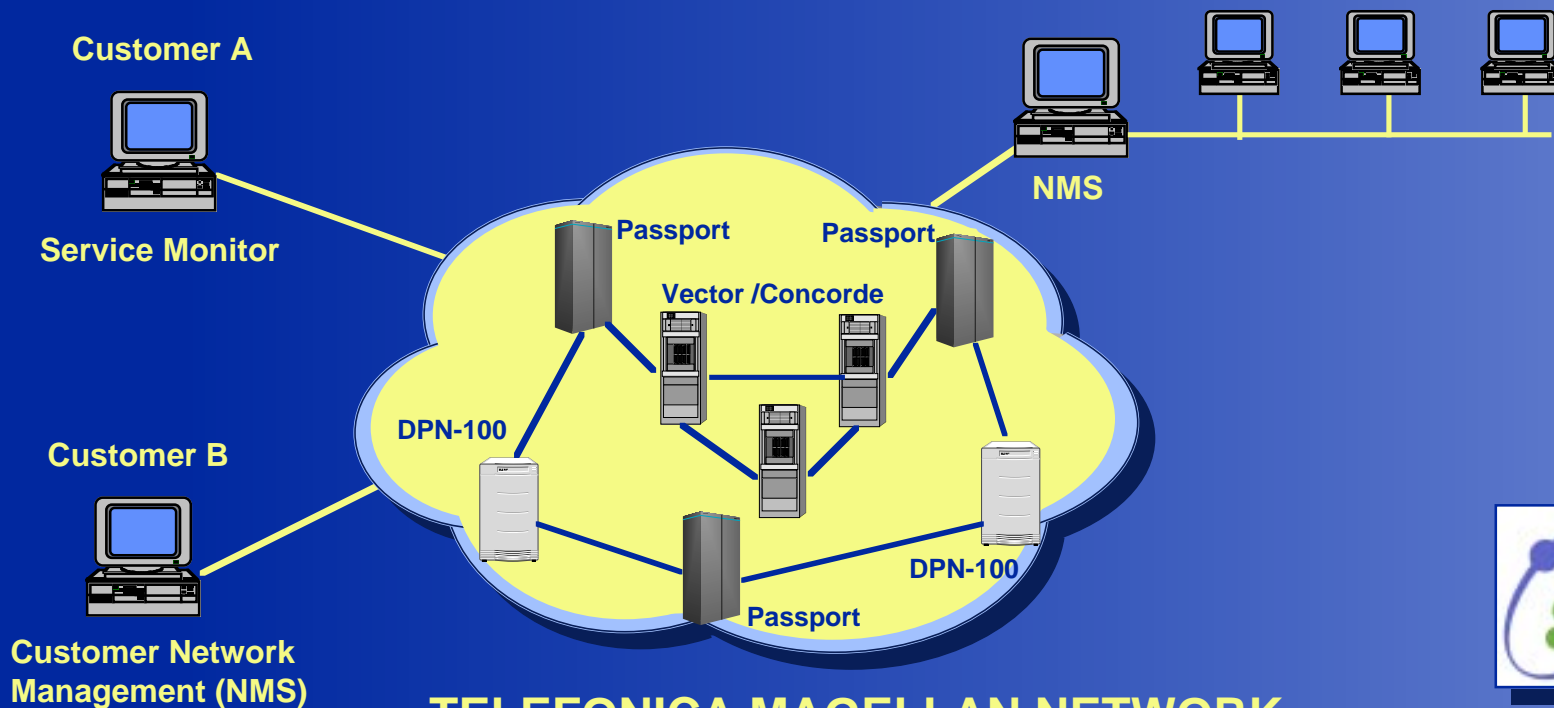

**TELEFONICA MAGELLAN NETWORK**



# Access

## LOW END

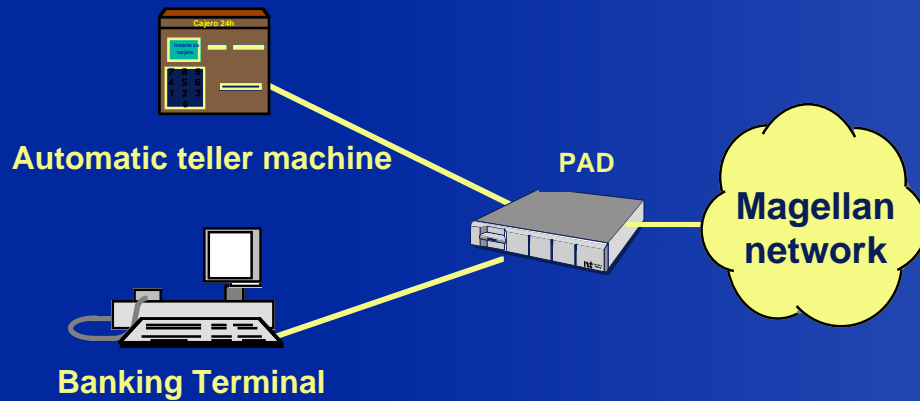

## HIGH END Servicio Cinco

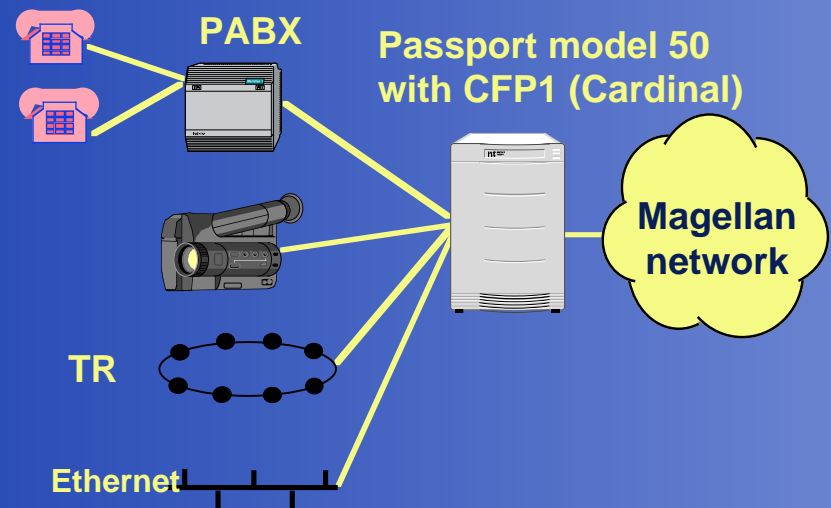

## MID RANGE Servicio Intervoz

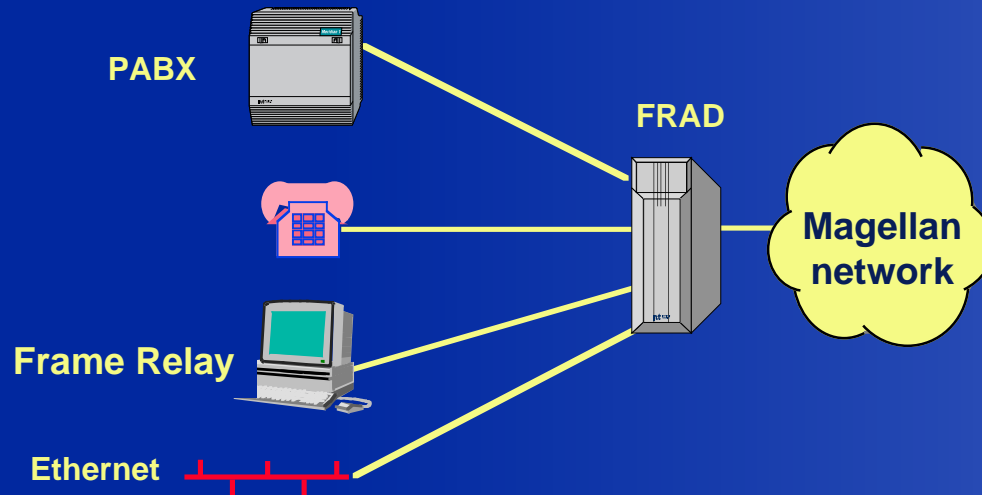

# Summary

- **Large stable network in partnership with Nortel**
- **Demand for high speed Frame Relay services growing very fast**
- **New customer and services challenge management objectives**
- **Passport at CPE's provides solid consolidation toward integrated multimedia**
- **Access technologies are increasing the number of choices**





# Canadian Imperial Bank of Commerce

---

**Mr. John Ostime**

**Director**

**Telecommunications Services**

**Banking, Operations and Information Technology  
Group**

**Personal and Commercial Banking Division**

**Canadian Imperial Bank of Commerce**

# Agenda

---

- Network Access Models
- Telefonica Presentation
- CIBC Presentation
- **Magellan Access Vision and Solutions**

# Evolving Customer Requirements

## Today's branch

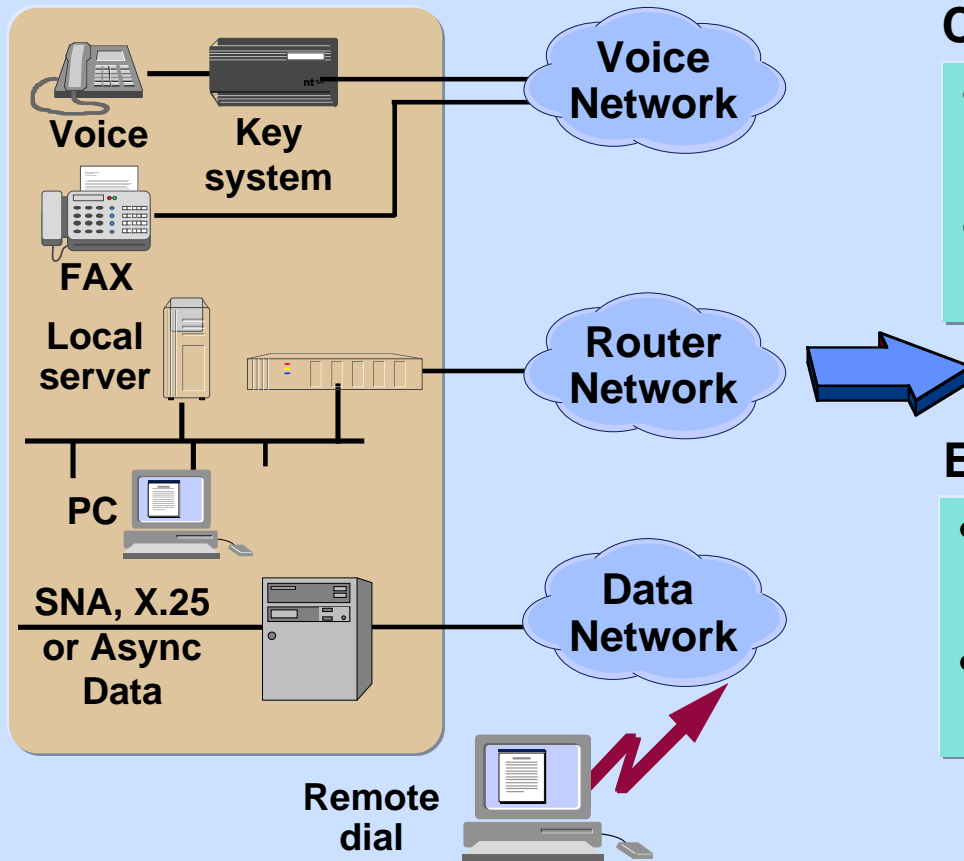

## Change drivers

- End-user demand for new applications and services
- Need for improved cost competitiveness

## Enablers

- Decreasing cost of processing power
- Accelerated pace of technology research

**New solutions required**



# Market-leading Magellan Access Products

## Magellan Access Switch

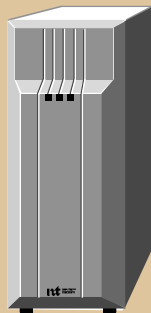

32-port fanout  
T1/E1 network links  
PBX interface  
Branch or remote access  
device  
ITI, X.25, SNA, FR,  
ISRB Service Support

12,000+ units deployed  
as of March 1, 1996

## DPN-100/1

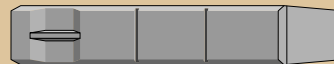

10-port panout  
Branch, CPE/CLE or  
remote access device  
ITI, X.25, SNA, frame relay  
service support

14,000+ units deployed  
as of March 1, 1996

Nortel share of  
packet switching  
access market  
= 40%

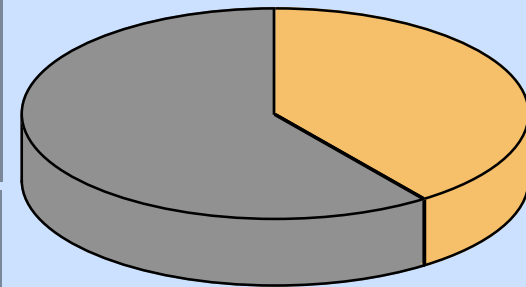

Source: Dataquest March 1996

**Proven access solutions**

# Magellan Access Products

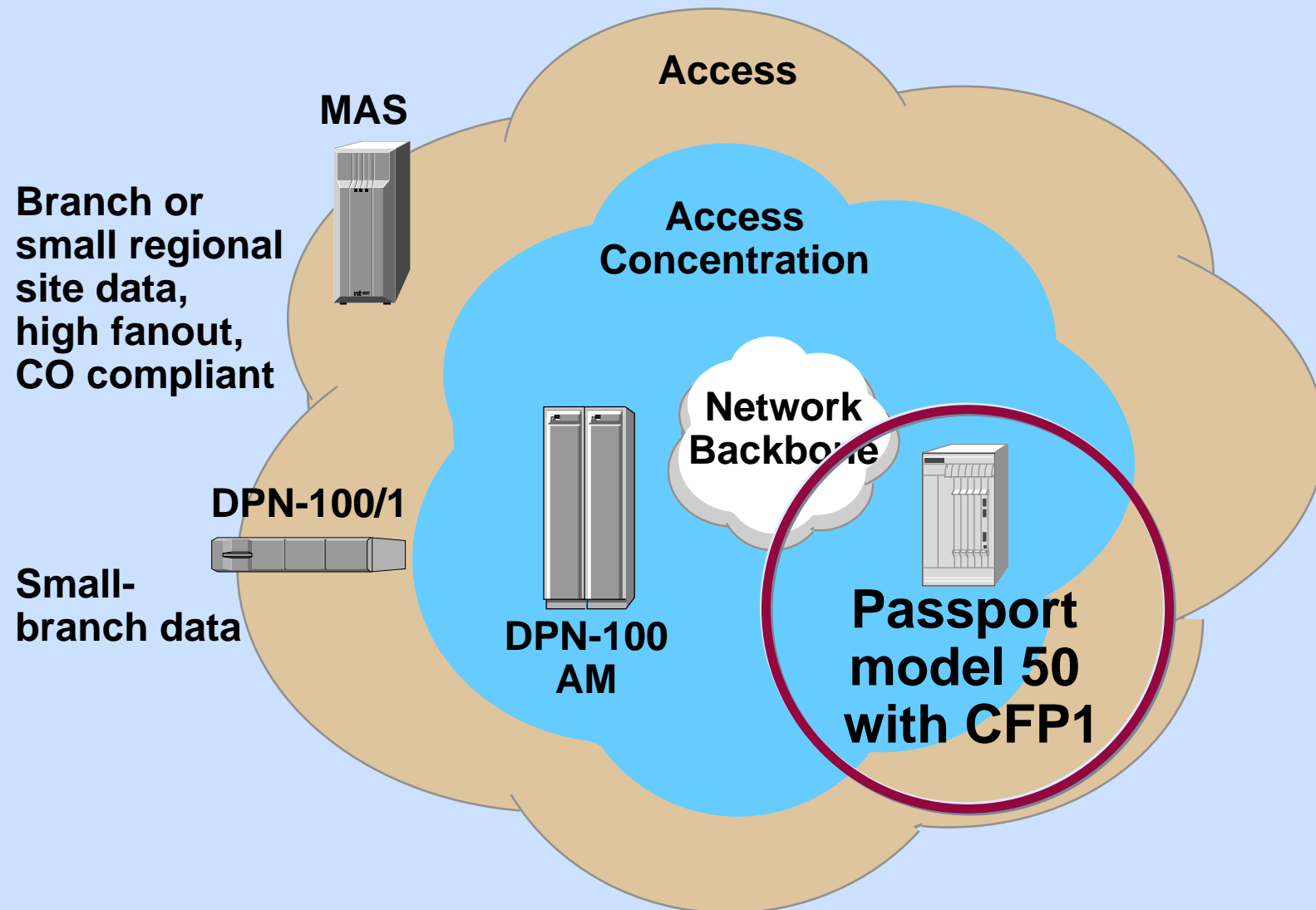

# Magellan Access Products

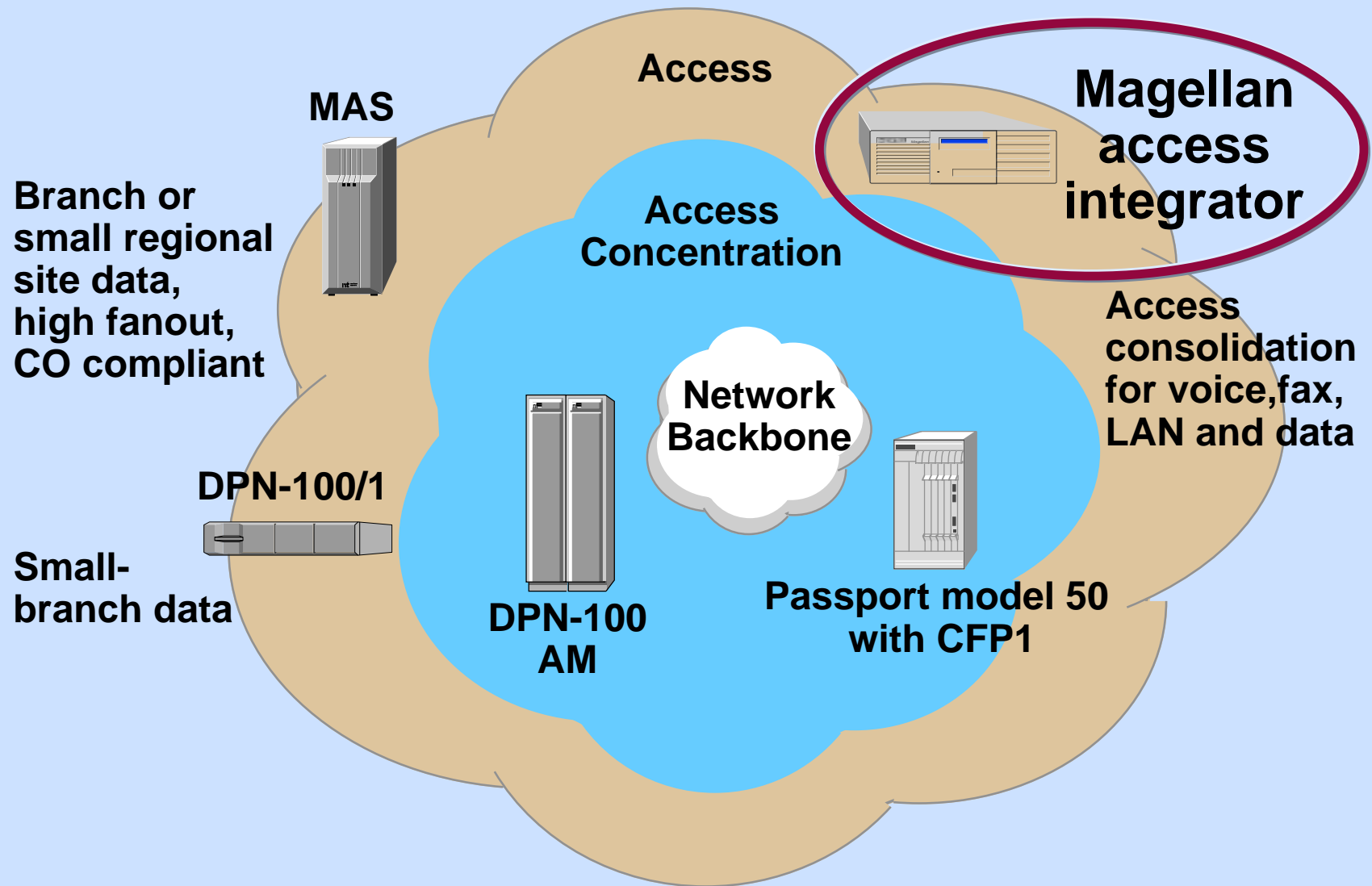

# Magellan Access Products

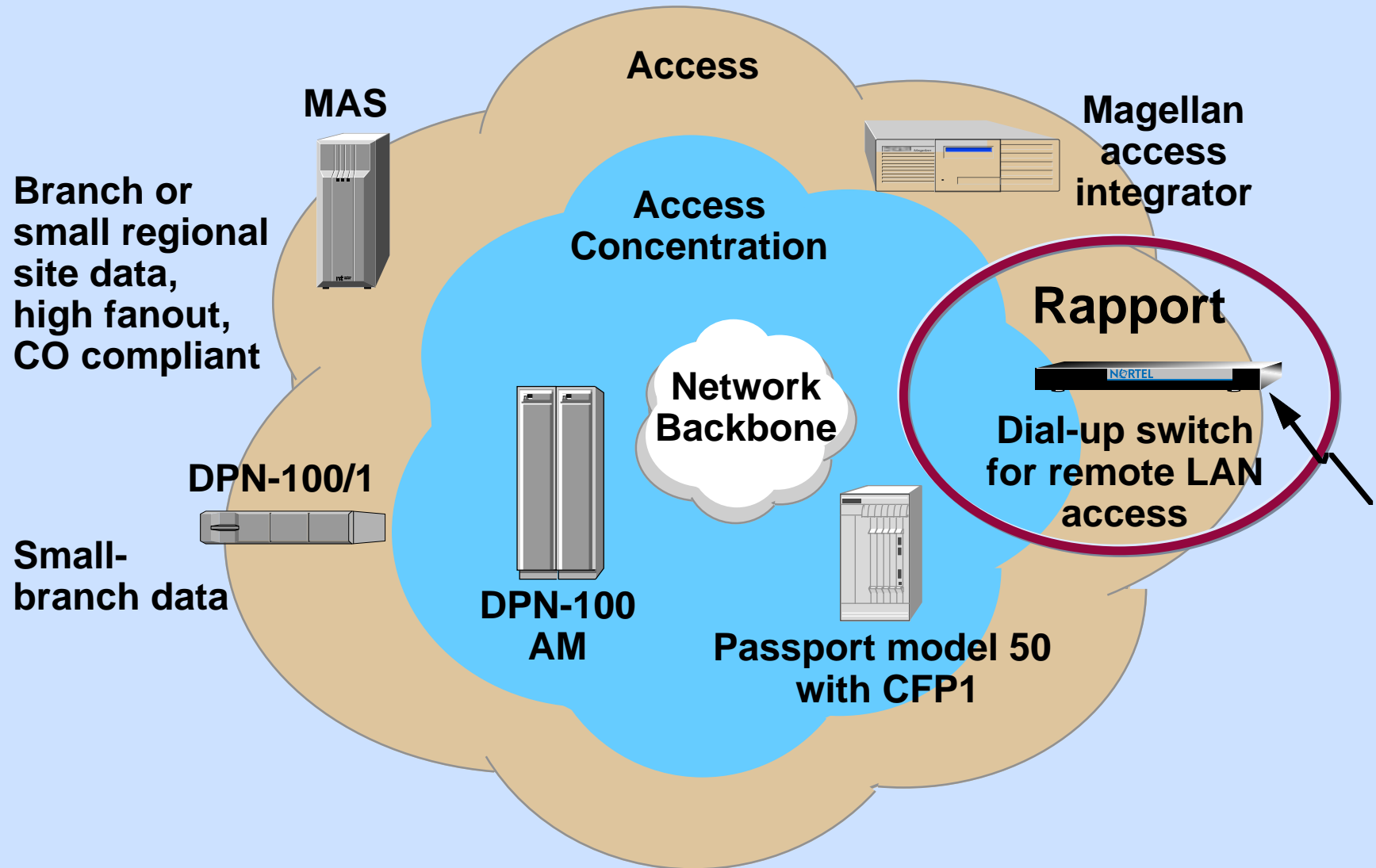

# Magellan Access Products

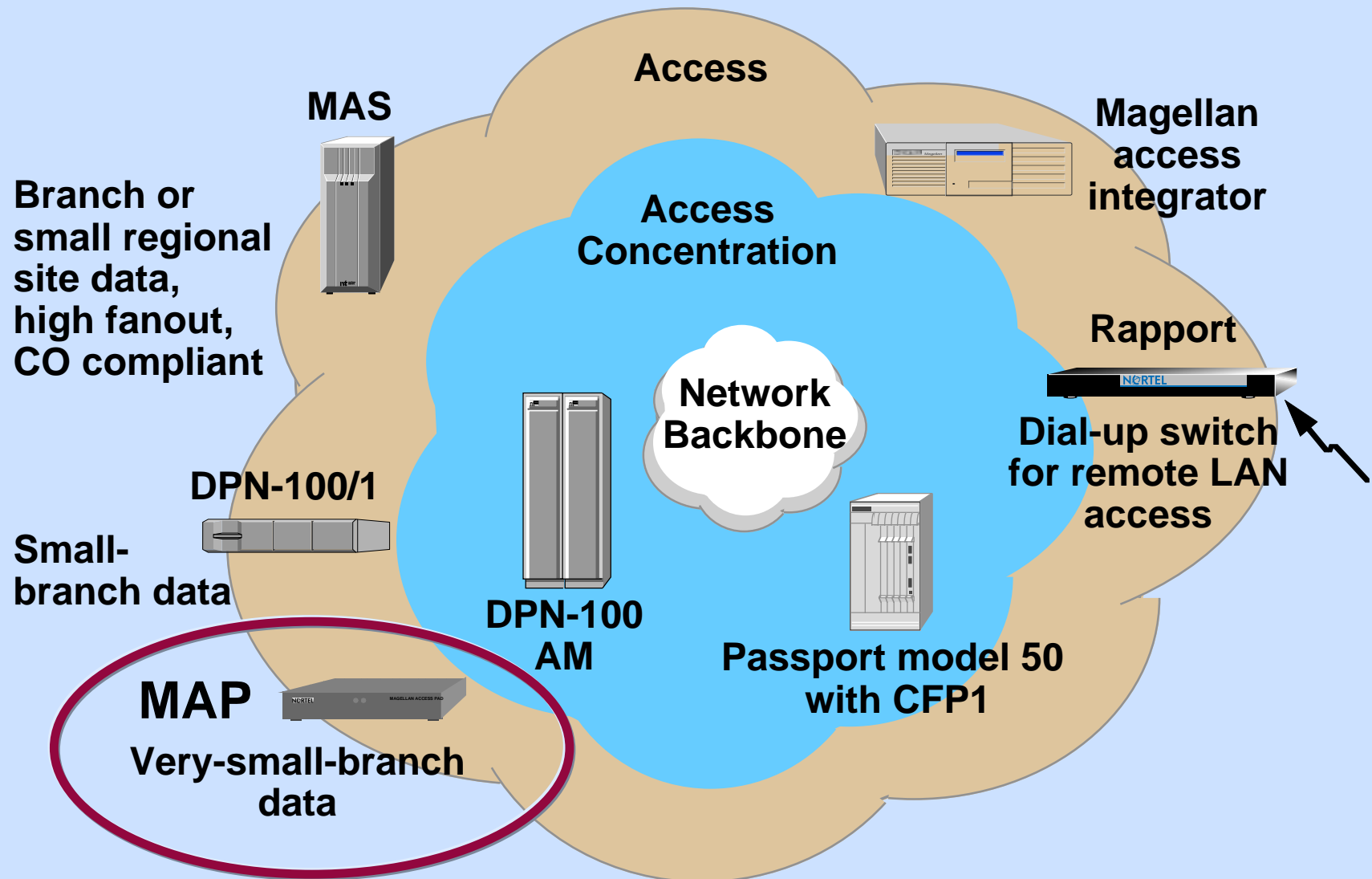

# Magellan Access Products

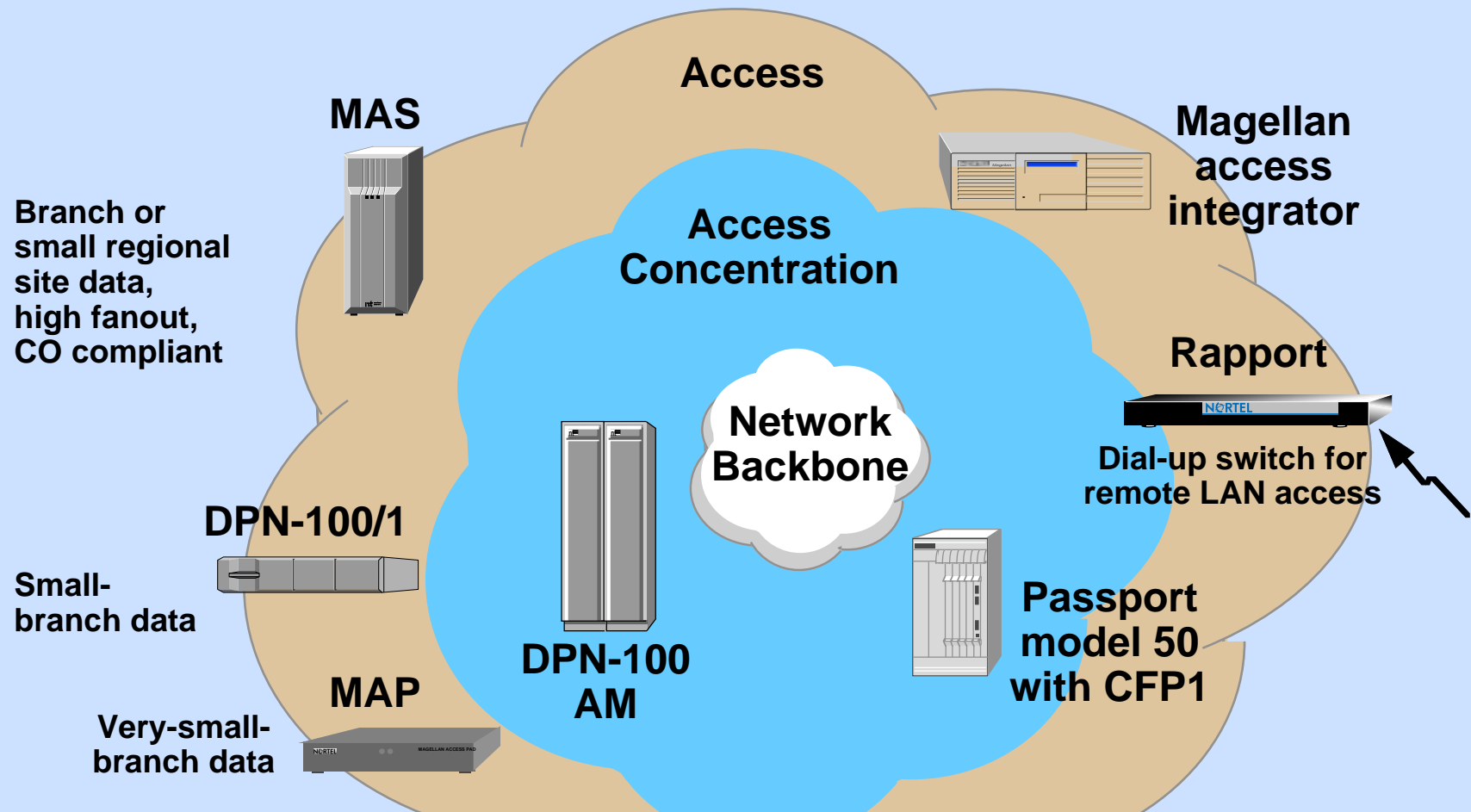

**Flexible solutions to address your address needs**

# Magellan Multimedia Access Vision

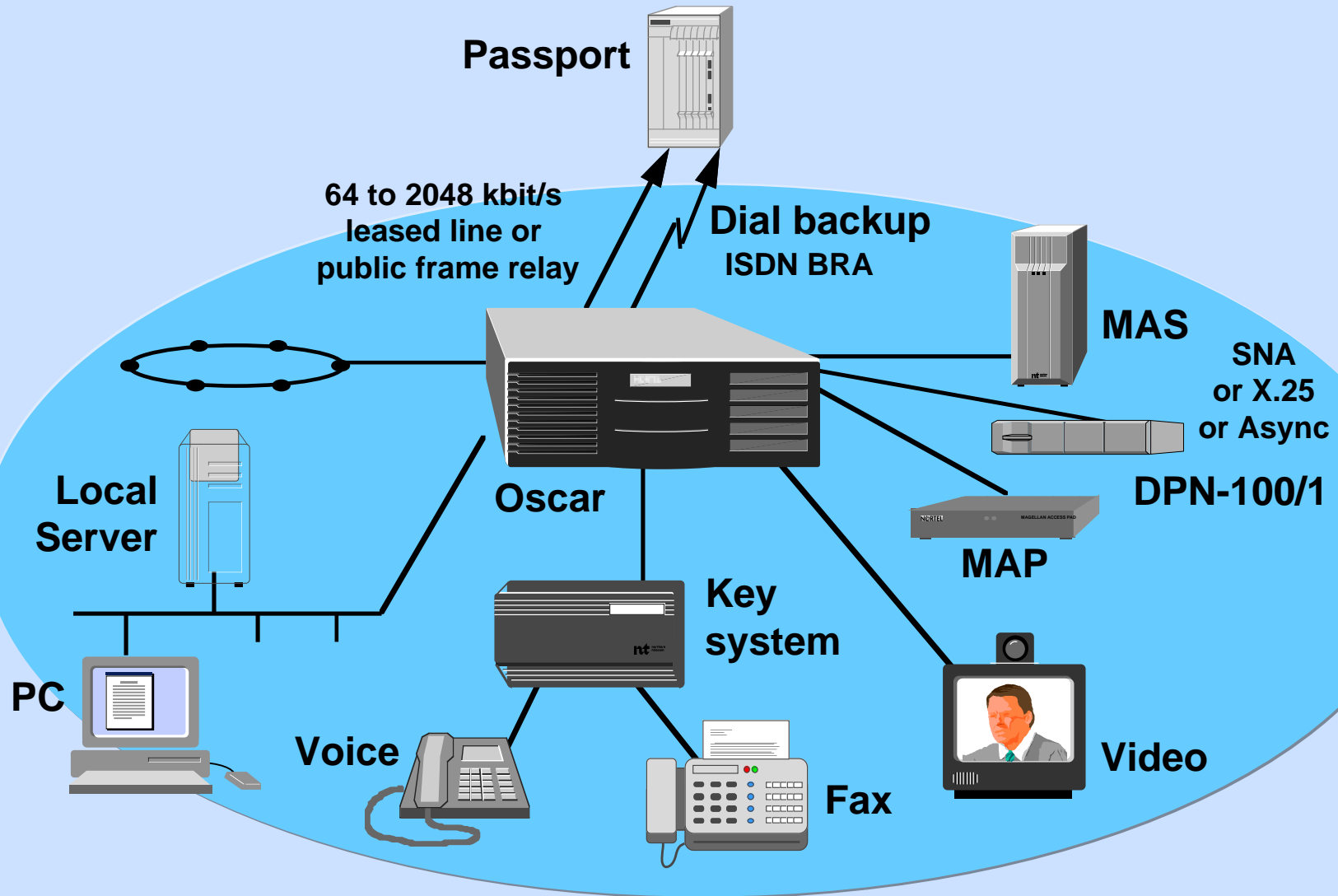

# Summary

---

- ✓ **Best-in-class solutions to help customers achieve business success**
- ✓ **Proven solutions for wide range of access requirements**
- ✓ **New solutions to address emerging multimedia access needs**