

(19)
(12)

(KR)
(B1)

(51) 。 Int. Cl.7
H04B 3/54

(45)
(11)
(24)

2004 12 23
10-0463439
2004 12 15

(21) 10-2002-0059090
(22) 2002 09 28

(65)
(43)

10-2004-0028021
2004 04 03

(73) 28-1

(72) 1-1206

96 222-1605

1114 204-1005

1 1 207-908

(74)
:

(54)

가 , 가 (22.9kv) 가 가
가 . 가

3

1

2

가 ,
 , EPDM
 0~3,000pF가 , 5,000 ~ 10,000 1,20
 2 , 3
 (22.9kV) (10) , 2 (A) (B)
 (C) (I1,I2) (C)가 T
 (I) (C) 가 (I) (100) (C)
 (122)가 (122) (100) (C) 3
 (123) (124) , EPDM
 (122) (124) (122)
 5,000 ~ 10,000 (126) (Ag 85%)
 1,200~3,000pF가 (125) (127)
 (127) (122)
 (125) (127) (solder paste) (122)
 (127) 8nF (127) (122)
 가 (100) (I)
 가 (132)
 (134) (134)가 (10) , 가 ()
 () (132)
 (C) (I) T
 가 , 가 ,
 가 .
 가 ,

(57)

1.
 (A) (B) (10)
 (100) ,
 (10) , (134)가 ,
 (132) 가 T (I1,I2) (I);
 (125)가 (127) (10) (122)

(C)가

2. 1 (122), (C) (122)가, EPDM (124) (123)
3. 1 (122) 5,000 ~ 10,000 (126)
 2 1,200~3,000pF가 (Ag) (solder paste) (127)
 (127)

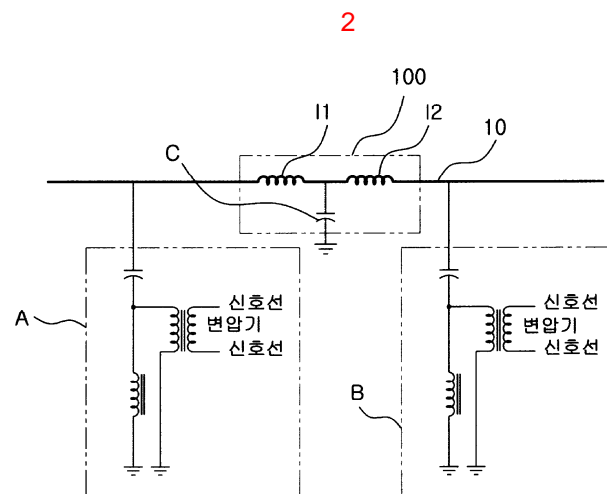
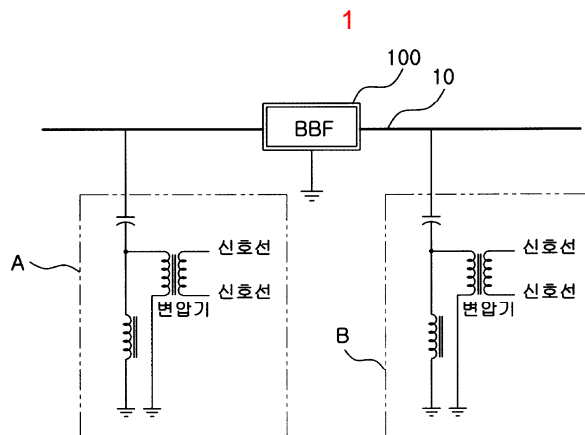

3

