

(19)
(12)

(KR)
(B1)

(51) 。 Int. Cl.⁷
H04B 3/54

(45)
(11)
(24)

2003 08 06
10-0394036
2003 07 25

(21) 10-2001-0011845
(22) 2001 03 07

(65)
(43)

2002-0071670
2002 09 13

(73) 4 873-29 4

(72) 329-1 105 1501

(74)
:

(54)

가

1

1
2 1
3a 3m 2
4 1

5 1
 6a 6f 2
 7 1
 8 1
 9 1
 < >
 1: 2:
 10: 20:
 30: 40:
 50: 60:

(Zero Cross Point)
 0261512 (: ,
)
 가 , 가

가
 가
 /
 "0" 2T "1" 1T "1" 1T
 "0" 2T /
 /
 "1" 가
 "1", "0" " "

1
 ") (20), (30), (40), (50) (10, " (60)
 (10) (10) (2) (1)
 0) (2)가 (1) (10) (1)
 (1) (2)
) (10) (20) (40) (50) (1) (Coupling)
 (40) (30) (2) (1)
 (50) (1) (2)
 (60) (1) 가 (40)가 (40)
 가 가 (50) (40) (20)
 (40)가 (1) (40) (50) (50)가 (50)가
 (40)가 (1) (40)가 (50)가 (50)가
 (Mute) (40)가 가 (100),
 2 (40) (102), (104), I (110), Q (112), 1 (114), 2 (100),
 (116), 1 (118), 2 (120), (122), (130), (132),
 / (134) (136)
 / (100) 8 (2) 가 3a
 (102) 8 가 3b
 (100) CRC(Cyclic Redundancy)
 3c
 (104) (I) (Q)
 (104) I Q 가 3c I Q
 I (110) I "1" "0" , 1 I 2 I 1 I I
 "1" , 2 I I "0" 1 2 I
 3d 가 , Q (112) Q "1" "0" , 1 Q 2 Q
 , 1 Q Q "1" , 2 Q Q "0"
 1 (114) 1 I 3e , 2 (116) 2 I
 3f 3g (114, 116) 3f 가 3g "1"
 3a (118) 1 Q , 2 (120) 2 Q , 1
 2 (120) 3h 3i (122) 1 2 (114, 116)
 1 2 (120) (T) 3j
 3f 3j , "0" "1" 2T (, (No signal)) , 1 2
 , I (118, 120) "1" "1" 2T (, (No signal)) , 1 2
 I "1" 1T (, (No signal)) , I "0" 2T
 "0" 2T (130) , Q "1" 1T , Q
 "100" (122) "1110" 가 3k
 (132) (122) 가 3l

/ (134) (132) / ,
 (20) (1) (136) (132) (50)
 , 2 (40)가 (132)가 (102)
 , 4 (136) (152) 4 가 (1
 18, 120) (156) 1 2 가 (1
 5 (50) (202), (204), (206), (50) / (210),
 (200), (212), I/Q (214), (216) / (218) .
 / (200) (20) (1) 가 2
 (50) , (40) (200) 3m 가 가 6a 6b
 , (40) 가 가 (1) ,
 , (200) 가 가 No Signal (200)
 (50) (1) 가 가 (40)가 ,
 (202) (40) PN , PN
 , (202) 6b PN
 (204) 가 6c (202) (206)
 . (208) (204) (2)
 , "1" 가
 . 가 6d (t)
 (210) , 6e , $0 < t < T$
 "1" , $T < t < 2T$ "0" , Data가 , $t=0$ " "
 (212) (210) (40) 가
 (Start) (End) I/Q (214)
 I/Q (214) , (Start) (End) (210)
 (216) I Q I Q 가 6f (218)
 (220) , I/Q (214)
 Q 가 가 가 ,
 , Q (60)
 7 1 (302), (304), (306) (308) (60) (300),
 (40)가 , 7 1 (30)
 (60) (1) 가 (50)
 , (40) (40) 5 (218) CRC
 7 , (N) (304) B (302) P (T) 2 1 B=2 P
 -1 . (304) (N) 가 (T) (306) (T)
 CRC (30) 가 가 (40) (308) (306) (N)
 , 7 (60) (300) ,
 가 ,

(40) Q (50)

가 (Q) , (50)

8 (40) 가 (60) (50)

(320) (60) 가 (50)

7 (P) (322) (328)

(60)가 (50)가 (40)

8 , I/Q Q Mute(No signal) , (50)

) (60) (340) (342) (60) 9

9 (342) 가 (340) (308) (N) (30)

(40)

가 가

가 가 가

(57)

1.

가 ; 가 ;

2.

1 가 / ;

"0" 2T "1" 1T "1" 1T

"0" 2T ;

/ / ;

3.

2 ,

2 4. , 가 ;
 "1" 1 1 , "0" ;
 2 "1" 1 ; 1 2 ;
 "0" 2 1 2 ; ;
 1 2 ; ;
 1 2 ; ;
 1 2 ; ;
 1 2 ; ;

4 5. , 가 ;
 1 2 , 1 2 ;

2 6. , 가 / ;
 "1" 가 ; "1", "0" " "
 ; ;
 ;

1 7. 6 , ;
 가 가 가 ; ,

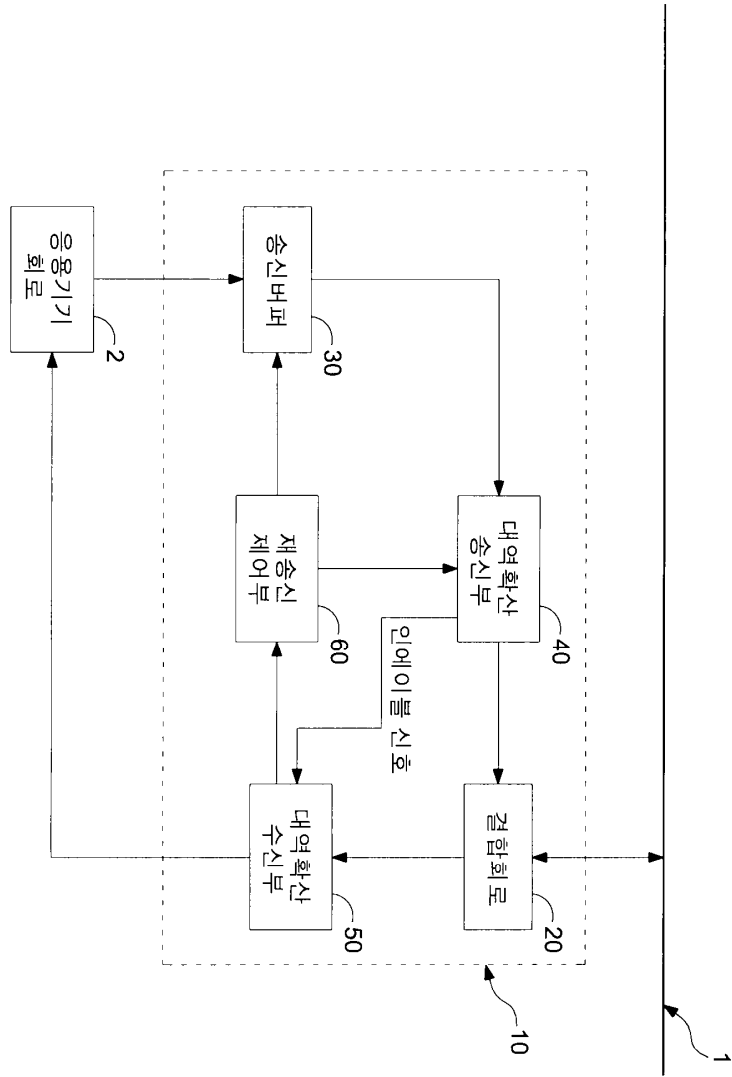

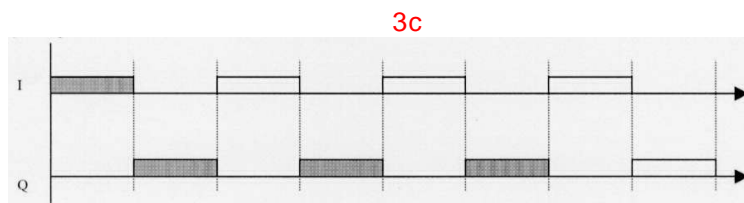
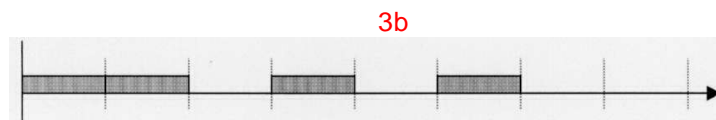
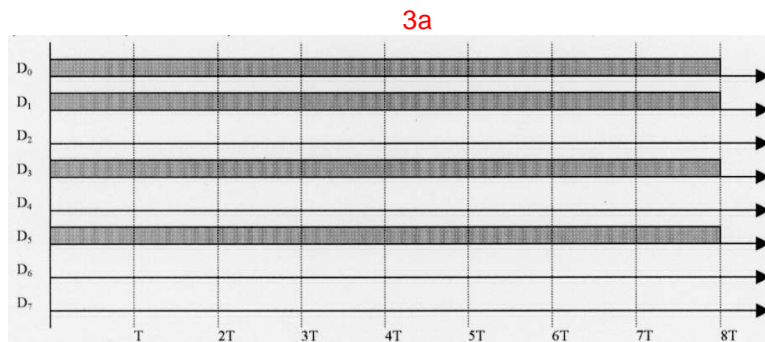
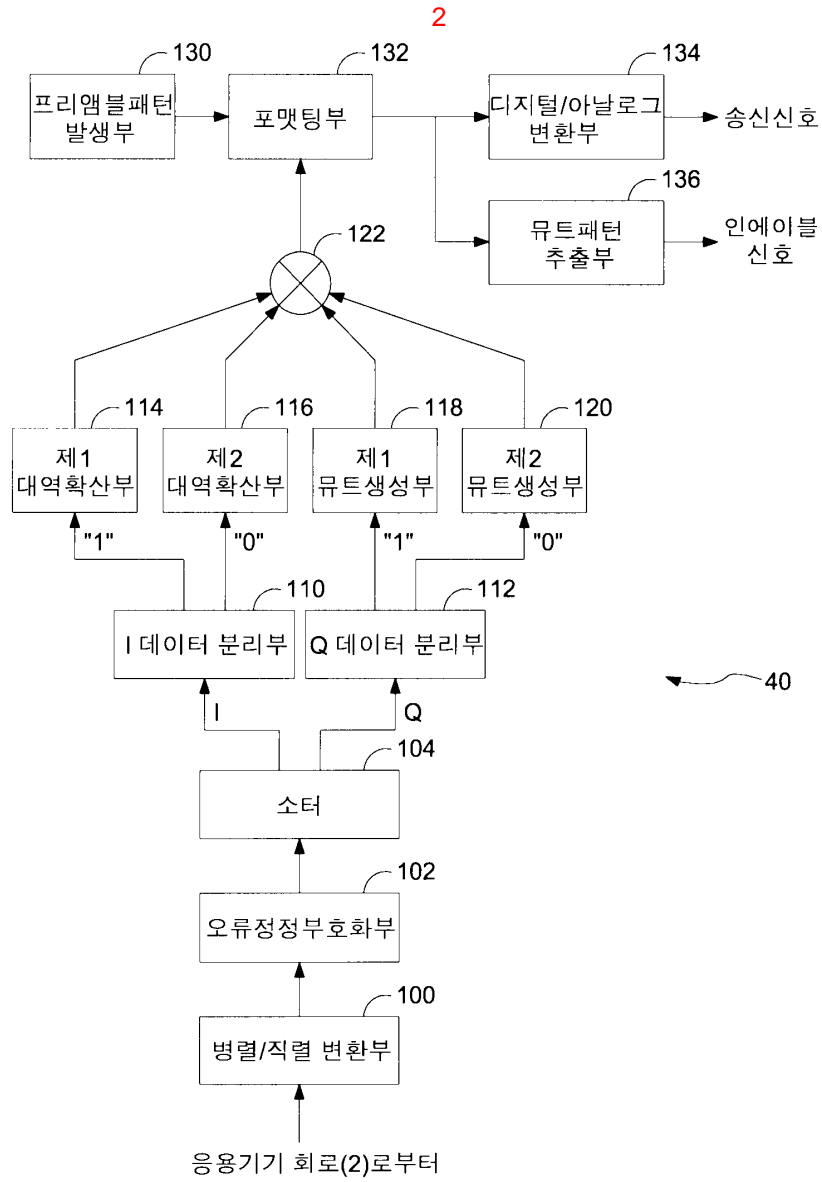

3d

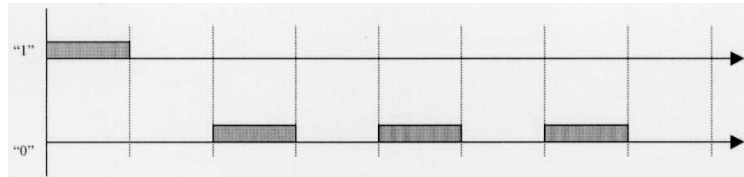

3e

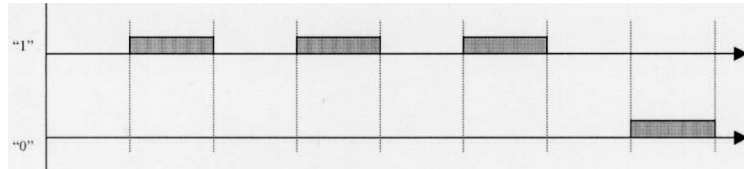

3f

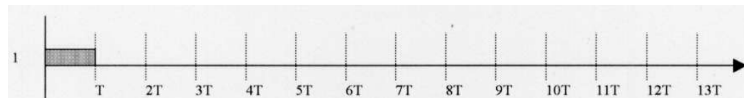

3g

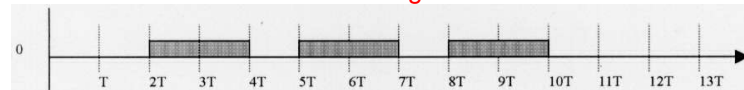

3h

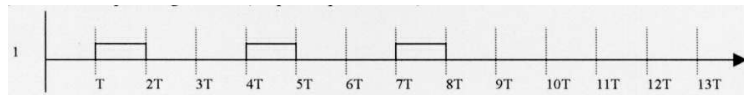

3i

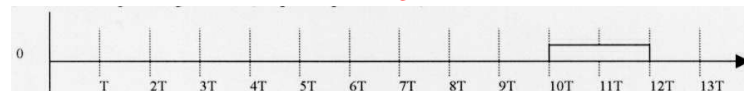

3j

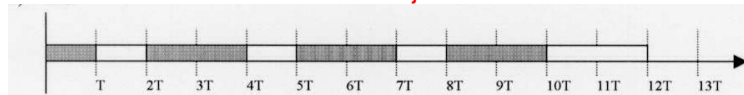

3k

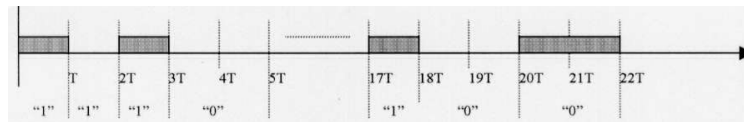

3l

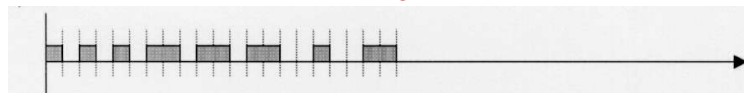

3m

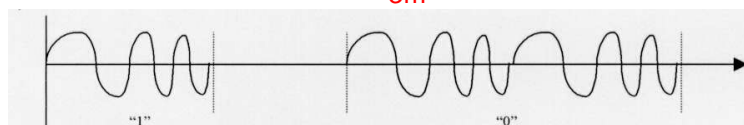

4

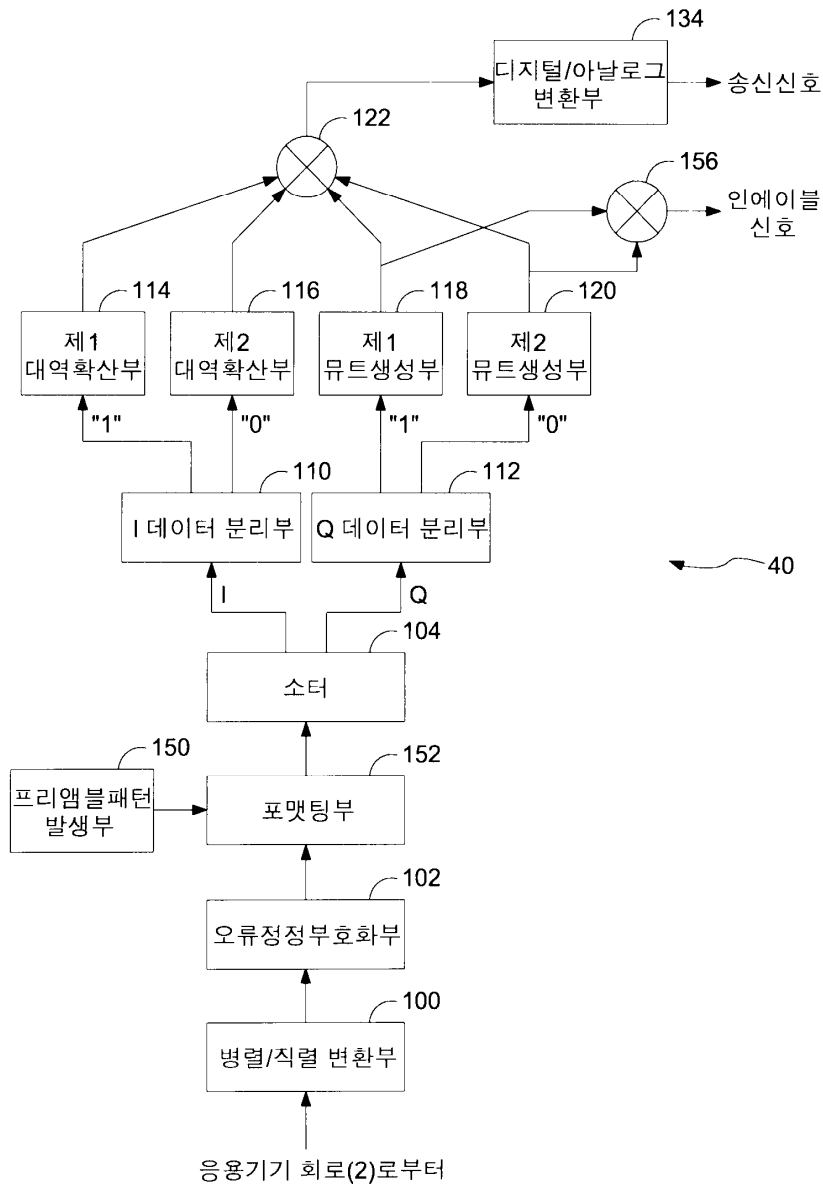

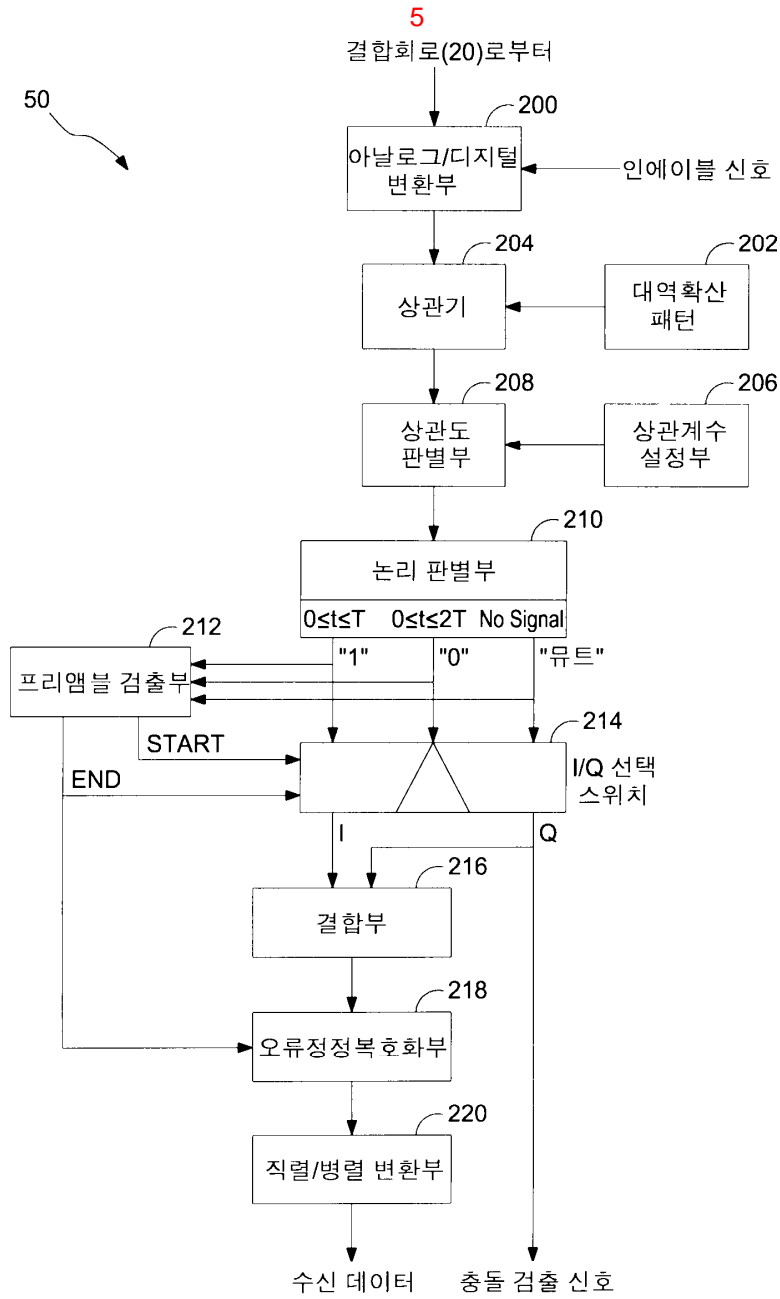

6a

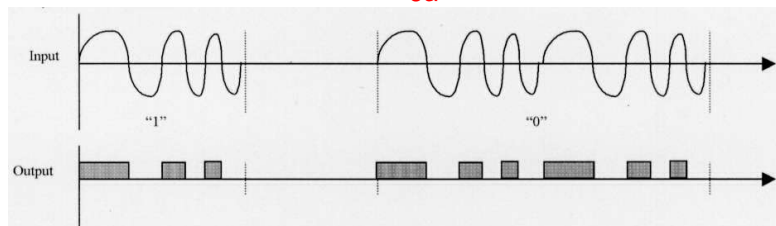

6b

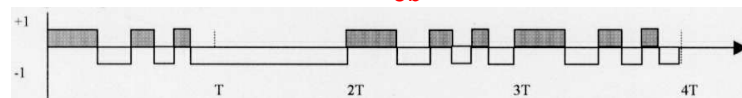

6c

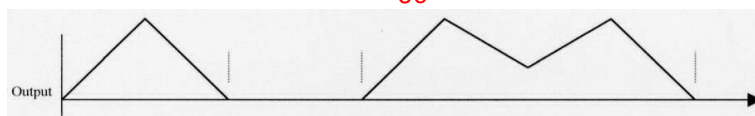

6d

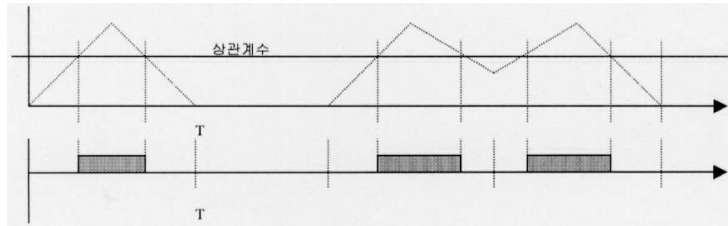

6e

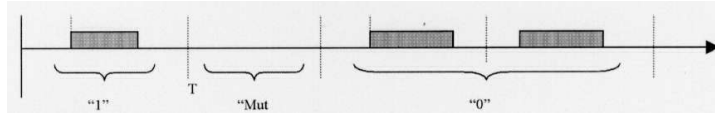

6f

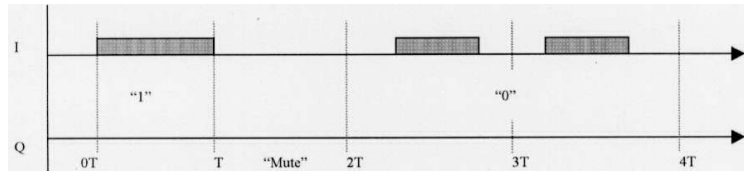

7

