

(19)
(12)

(KR)
(Y1)

(51) 。 Int. Cl. ⁷
H05B 37/02

(45)
(11)
(24)

2003 04 21
20 - 0310279
2003 03 31

(21) 20 - 2003 - 0000501
(22) 2003 01 08

(73) 140 - 25 (32/2)

(72) 140 - 25 (32/2)

(74)

:

가 :

(54)

가 , , 가 가

(400); (410); (430) / (430)

2a

,

1a

1b

1c

2a

2b

가 (, " ")

, 1a 1c

1a

0~50 가 (가)(130 - 1 130 - n) 가 ON/OFF 가 (100) 4

가

가

(130 - n) 가

(120 - n)

가

가 가
1b

ON/OFF

가 가
가 가

가 가
1c

가 가

가 가 가

(400); (410); (430) / (430)
0) (400) (401); (410) / (430)
(406); (401); (410) (403);

(410) (405); 가 (410)
(410) (404); (405) (410)
(410) (406) (410)
(410) (404) (402)

, / 가
,
,
,

2a

(430) (POWER LINE CARRIER) (400),
/
/
(420) (430) 가 (410),

(410) 2b (400)

(403), (400) , (401),
(406) (406) (401), (404), (405), 가
(402) (401), (406), (410) 405

(406) (401) , (410)
(406)

(406) , (410) (411) , (411)
(60 - 140Hz) (411) (4)
06)

(410) (403) , (430) /
(410) (410) (405)

(404) , , , / ,

(410)

(402) , (405) (410)

(406) (404) , (410) (405) (410) (406) (405) (410) (406) (410)

06) (402) (405) (410)

10) (410) (410) (410)

2b (410) 2a (410)

(400) , (411), (413),

(414), (415), (411) (400) / / (415) (412), (41

2) (430) (417) (400)

(416)

(411) (400) (415),

6) (416) (411) (400)

(417) (420) (430) (411) (415),

(416) , (400) (406)

(401, 411) (400) (406)

(413) , (410)가 (430) , , / ,

가 (413) (410)

(412) , (416) (400) 가

(417) (430) / (415) (400)

(417) (416) (400)

(415) , (412)

/ (412)

(430) (417) , (412) /

가 (410)

, (400) (405) (/) (410)

(417) / (410)

, (400) (410) / (410)

, (400) (405) (402) (410)

, (410) (415) (416) (417) /

(400) (400)

(400) /

가

가

가

(57)

1.

(430) (400);

(410);

/ (430)

(400) ,

(401);

(410)

(406);

(403);

(410)

(405);

가 (410)

(404);

(405)

(410)

(406)

(410)

(410)

(404)

(402)

2.

1 ,

(410) ,

(411);

(400)

(416)

(413);

(414);

, / , ,

(415);

(400)

(416)

(415)

(416)

/

(40

0)

(412);

(412)

(430)

(417)

1a

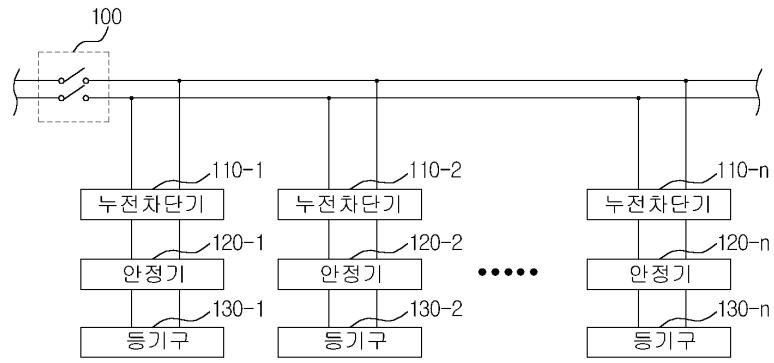

1b

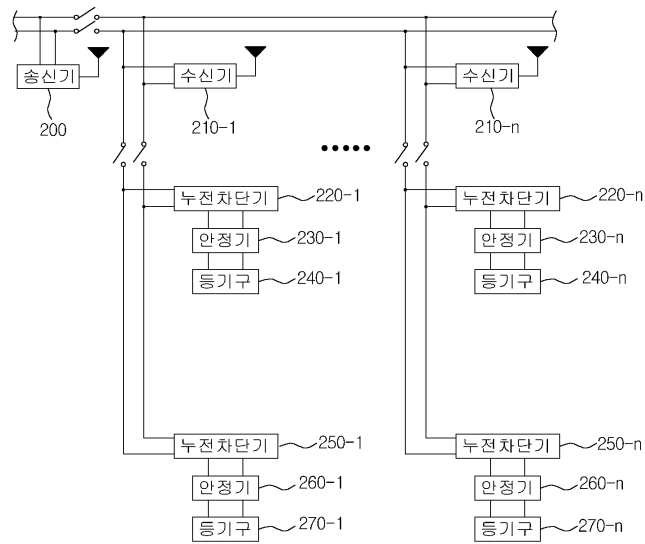

1c

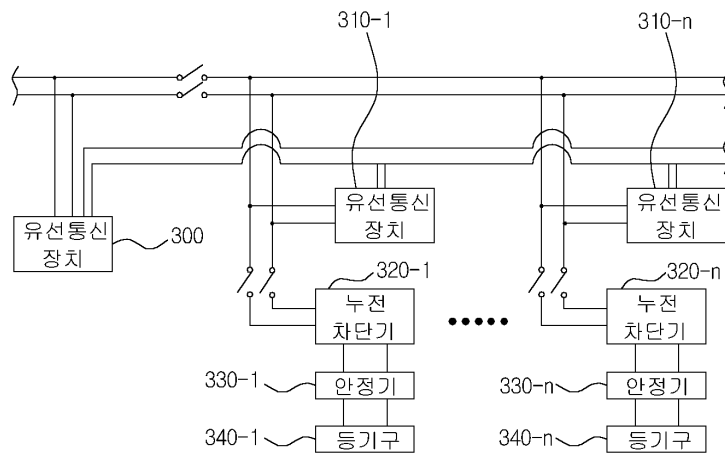

2a

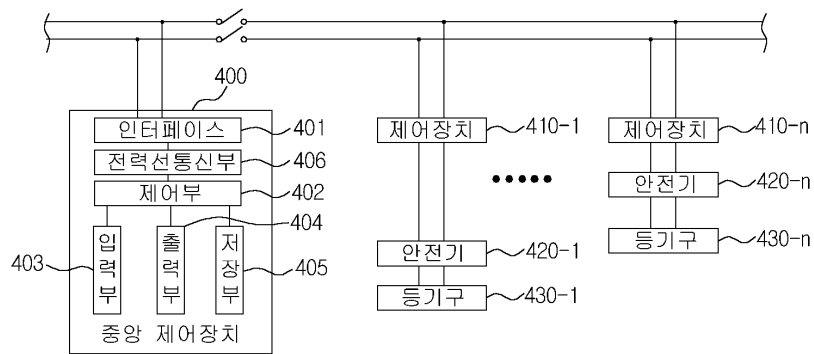

2b

