

(19)  
(12)

(KR)  
(B1)

(51) 。 Int. Cl.7  
H04B 3/54

(45)  
(11)  
(24)

2003 09 02  
10-0396666  
2003 08 21

(21) 10-2001-0021431  
(22) 2001 04 20

(65)  
(43)

2002-0081915  
2002 10 30

(73) 20 LG

(72) 31-304

(74)

:

(54) /

2 / , 1 , / 1 / / ,  
1 /

4

/

1 /  
2 3 /  
4 /  
5 3





, 1 (110) 2 / (200) 2  
 , 1 (120) 1 (110)  
 , 1 (130) 1 (130)  
 ) , 1 (110) 1 (130)  
 , 2  
 , 1 (130) 1 (140)  
 , 1 (150) 1 (140)  
 , 220V AC 1 (150) 1 (140)  
 , 1 / (100) 2 / (200) 2 (200)  
 (250) 1 / (100) 2 / (200) 2  
 , 2 (260) 2 (260)  
 , 3 3 5 가  
 , 5 2 (260) 2 (210)  
 , / (210) "A"  
 , 2 (210) (T) "B" (Transient) 가  
 (Sampling)  
 , 2 (210) T  
 , / (260) 2 (270)  
 , 2 (210)  
 , 2 / (200) 1 / (100)  
 0) , 2 / (200) 1 / (10)  
 , 1 (110)  
 , 6a 2 / (200)  
 (S100),  
 (S110). /  
 , 1 (110)  
 (S120). 가  
 1 (S120), (120) (S130).  
 , 1 (120) 1 (110)  
 (+ ) 가 (S140).  
 , + 가 1 / (100) 2 /  
 (200) , 6b 2 / (200) 1 /  
 (100) 1 (110) (S200). (S210).  
 , / 가  
 , 1 (110) (S220). 가  
 (S220), 가 1 (120)  
 , 1 + (110) 가 + 가 (S240).  
 , 1 (110) 가 1 (110)  
 , 1 (110) (S220), (- )  
 1 (120) (S250).  
 , 1 (110) - (S260).  
 , 6c -

(S120), 2 / (200)  
 (S150).  
 0) 2 1 / (100) 2 / (20) (110)  
 (200) 2 / (200) 1 / (100) 1 / (10)  
 0) 1 2 / .  
 , 가 가

(57)

1.

/ 1 / , 1  
 1 / 2 1  
 1 / .

2.

1 , 2 ,  
 2 2 / ,  
 1 1 , 1  
 , 1 / .

3.

/ 1 1 ; 1  
 1 / ; 2  
 1 ; , / .

4.

3 , 가 1 1  
 가 1 , 가 가  
 1 / .

5.

4 가 1 1 / .

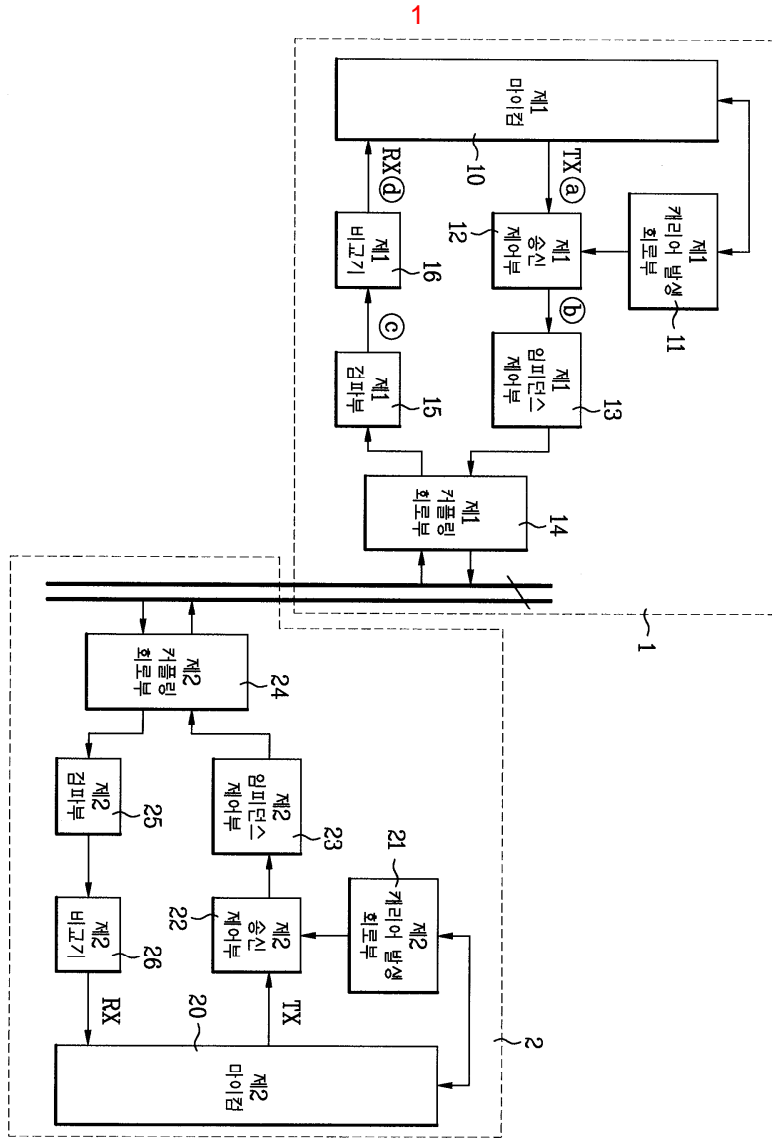

2

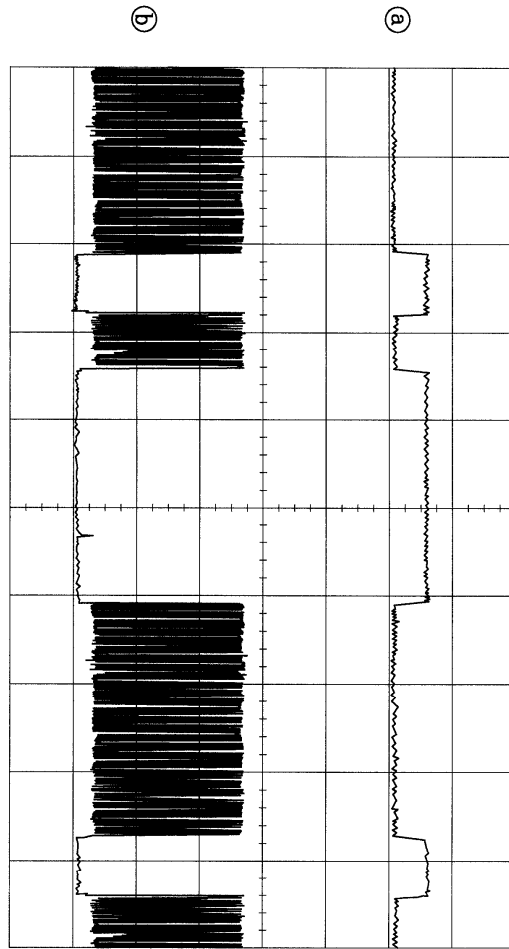

3

Ⓟ

Ⓢ

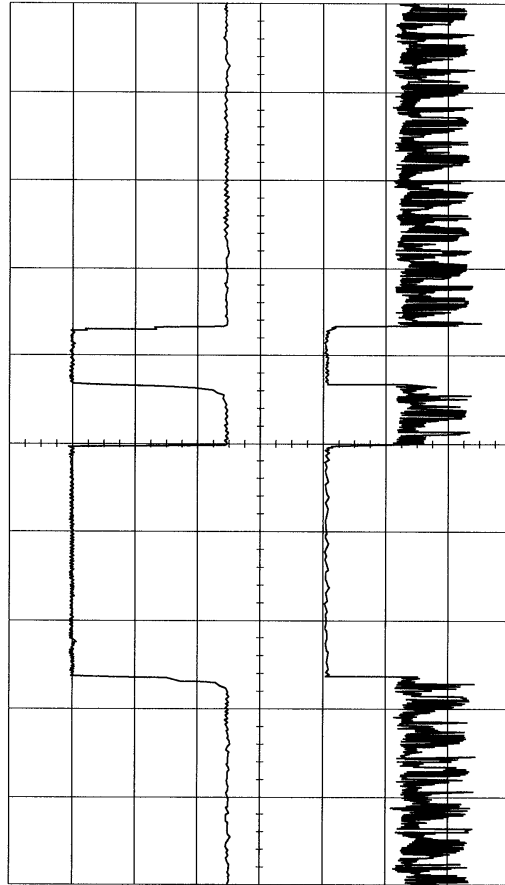



4

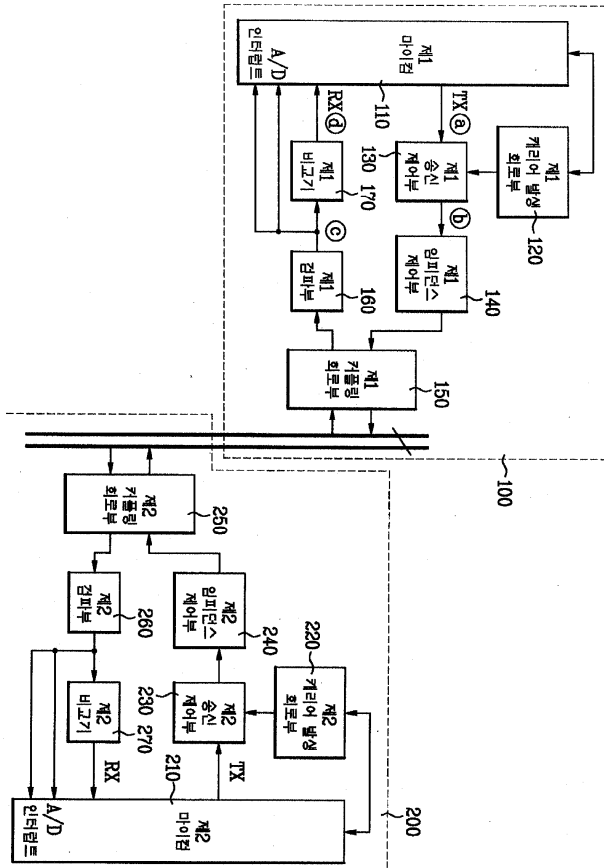

5

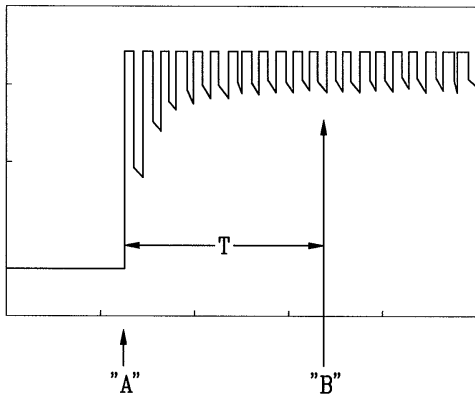

6a

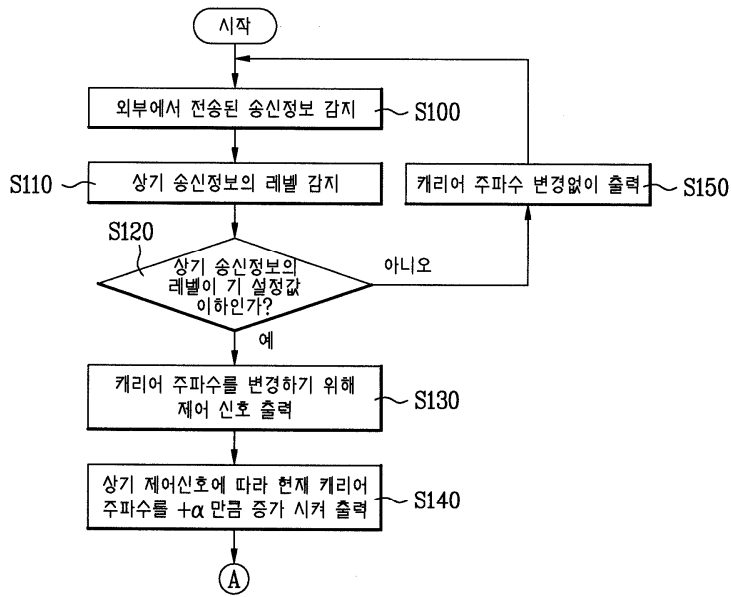

6b

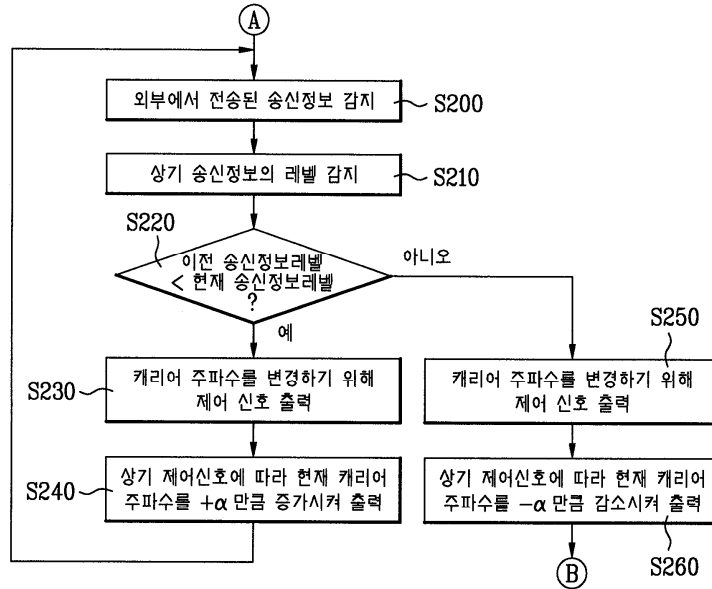

6c

