

Each Atmel datasheet includes an Ordering Information section which specifies the package types available. This section provides size specifications and outlines for all package types.⁽¹⁾

| Package | Description | See Page |
|---------|--|----------|
| 32A | 32-lead, Low-profile (1.4 mm) Plastic Quad Flat Package (LQFP) | 5 |
| 44A | 44-lead, Thin (1.0 mm) Plastic Quad Flat Package (TQFP) | 5 |
| 48A | 48-lead, Low-profile (1.4 mm) Plastic Quad Flat Package (LQFP) | 5 |
| 64A | 64-lead Thin (1.0 mm) Plastic Quad Flat Package (TQFP) | 5 |
| 100A | 100-lead, Thin (1.0 mm) Plastic Quad Flat Package (TQFP) | 6 |
| 144A | 144-lead, Low-profile (1.4 mm) Plastic Quad Flat Package (LQFP) | 6 |
| 32B | 32-lead, 0.600" Wide, Ceramic Side Braze Dual Inline (Side Braze) | 6 |
| 40B | 40-lead, 0.600" Wide, Ceramic Side Braze Dual Inline (Side Braze) | 6 |
| 352B | 352-ball Ball Grid Array (BGA) | 7 |
| 432B | 432-ball Ball Grid Array (BGA) | 7 |
| 8C | 8-lead, 0.230" Wide, Leadless Array Package (LAP) | 7 |
| 8C1 | 8-lead, 0.300" Wide, Leadless Array Package (LAP) | 7 |
| 14C1 | 14-ball, Plastic Chip-scale Ball Grid Array (CBGA) | 8 |
| 24C1 | 24-ball, Plastic Chip-scale Ball Grid Array Package (CBGA) | 8 |
| 24C2 | 24-ball, Plastic Chip-scale Ball Grid Array Package (CBGA) | 8 |
| 24C3 | 24-ball, Plastic Chip-scale Ball Grid Array (CBGA) | 8 |
| 42C1 | 42-ball, Plastic Chip-scale Ball Grid Array Package (CBGA) | 9 |
| 42C2 | 42-ball, Plastic Chip-scale Ball Grid Array Package (CBGA) | 9 |
| 44C1 | 44-ball, Plastic Chip-scale Ball Grid Array (CBGA) | 9 |
| 48C1 | 48-ball, Plastic Chip-scale Ball Grid Array Package (CBGA) | 9 |
| 48C2 | 48-ball, Plastic Chip-scale Ball Grid Array Package (CBGA) | 10 |
| 48C3 | 48-ball, Plastic Chip-scale Ball Grid Array Package (CBGA) | 10 |
| 72C1 | 72-ball, Plastic Chip-scale Ball Grid Array Package (CBGA) | 10 |
| 120C1 | 120-ball, Plastic Chip-scale Ball Grid Array Package (CBGA) | 10 |
| 16D3 | 16-lead, 0.300" Wide, Non-windowed, Ceramic Dual Inline Package (Cerdip) | 11 |
| 20D3 | 20-lead, 0.300" Wide, Non-windowed, Ceramic Dual Inline Package (Cerdip) | 11 |

Note: 1. Dimensions shown do not include lead plating or mold flash.



Standard Package Outlines





| Package | Description | See Page |
|----------------|--|-----------------|
| 24D3 | 24-lead, 0.300" Wide, Non-windowed, Ceramic Dual Inline Package (Cerdip) | 11 |
| 24D6 | 24-lead, 0.600" Wide, Non-windowed, Ceramic Dual Inline Package (Cerdip) | 11 |
| 28D6 | 28-lead, 0.600" Wide, Non-windowed, Ceramic Dual Inline Package (Cerdip) | 12 |
| 32D6 | 32-lead, 0.600" Wide, Non-windowed, Ceramic Dual Inline Package (Cerdip) | 12 |
| 40D6 | 40-lead, 0.600" Wide, Non-windowed, Ceramic Dual Inline Package (Cerdip) | 12 |
| 24DW3 | 24-lead, 0.300" Wide, WIndowed, Ceramic Dual Inline Package (Cerdip) | 12 |
| 24DW6 | 24-lead, 0.600" Wide, Windowed, Ceramic Dual Inline Package (Cerdip) | 13 |
| 28DW6 | 28-lead, 0.600" Wide, Windowed, Ceramic Dual Inline Package (Cerdip) | 13 |
| 32DW6 | 32-lead, 0.600" Wide, Windowed, Ceramic Dual Inline Package (Cerdip) | 13 |
| 40DW6 | 40-lead, 0.600" Wide, Windowed, Ceramic Dual Inline Package (Cerdip) | 13 |
| 42DW6 | 42-lead, 0.600" Wide, Windowed, Ceramic Dual Inline Package (Cerdip) | 14 |
| 28F | 28-lead, Non-windowed, Ceramic Bottom-brazed Flat Package (Flatpack) | 14 |
| 32F | 32-lead, Non-wIndowed, Ceramic Bottom-brazed Flat Package (Flatpack) | 14 |
| 20J | 20-lead, Plastic J-leaded Chip Carrier (PLCC) | 14 |
| 28J | 28-lead, Plastic J-leaded Chip Carrier (PLCC) | 15 |
| 32J | 32-lead, Plastic J-leaded Chip Carrier (PLCC) | 15 |
| 44J | 44-lead, Plastic J-leaded Chip Carrier (PLCC) | 15 |
| 68J | 68-lead, Plastic J-leaded Chip Carrier (PLCC) | 15 |
| 84J | 84-lead, Plastic J-leaded Chip Carrier (PLCC) | 16 |
| 32K | 32-lead, Non-windowed, Ceramic J-leaded Chip Carrier (JLCC) | 16 |
| 44K | 44-lead, Non-windowed, Ceramic J-leaded Chip Carrier (JLCC) | 16 |
| 28KW | 28-lead, Windowed, Ceramic J-leaded Chip Carrier (JLCC) | 16 |
| 32KW | 32-lead, Windowed, Ceramic J-leaded Chip Carrier (JLCC) | 17 |
| 44KW | 44-lead, Windowed, Ceramic J-leaded Chip Carrier (JLCC) | 17 |
| 68KW | 68-lead, Windowed, Ceramic J-leaded Chip Carrier (JLCC) | 17 |
| 20L | 20-pad, Non-windowed, Ceramic Leadless Chip Carrier (LCC) | 17 |
| 28L | 28-pad, Non-windowed, Ceramic Leadless Chip Carrier (LCC) | 18 |
| 32L | 32-pad, Non-windowed, Ceramic Leadless Chip Carrier (LCC) | 18 |
| 44L | 44-pad, Non-windowed, Ceramic Leadless Chip Carrier (LCC) | 18 |
| 28LW | 28-pad, Windowed, Ceramic Leadless Chip Carrier (LCC) | 18 |
| 32LW | 32-pad, Windowed, Ceramic Leadless Chip Carrier (LCC) | 19 |
| 44LW | 44-pad, Windowed, Ceramic Leadless Chip Carrier (LCC) | 19 |
| 8M | 8-lead, 0.118" Wide, Miniature Small Outline (MSOP) | 19 |
| 48M1 | 48-ball, Micro Ball Grid Array Package (μ BGA) | 19 |
| 8P3 | 8-lead, 0.300" Wide, Plastic Dual Inline Package (PDIP) | 20 |



| Package | Description | See Page |
|---------|--|----------|
| 16P3 | 16-lead, 0.300" Wide, Plastic Dual Inline Package (PDIP) | 20 |
| 20P3 | 20-lead, 0.300" Wide, Plastic Dual Inline Package (PDIP) | 20 |
| 24P3 | 24-lead, 0.300" Wide, Plastic Dual Inline Package (PDIP) | 20 |
| 28P3 | 28-lead, 0.300" Wide, Plastic Dual Inline Package (PDIP) | 21 |
| 24P6 | 24-lead, 0.600" Wide, Plastic Dual Inline Package (PDIP) | 21 |
| 28P6 | 28-lead, 0.600" Wide, Plastic Dual Inline Package (PDIP) | 21 |
| 32P6 | 32-lead, 0.600" Wide, Plastic Dual Inline Package (PDIP) | 21 |
| 40P6 | 40-lead, 0.600" Wide, Plastic Dual Inline Package (PDIP) | 22 |
| 42P6 | 42-lead, 0.600" Wide, Plastic Dual Inline Package (PDIP) | 22 |
| 44Q | 44-lead, Plastic Gull Wing Quad Flat Package (PQFP) | 22 |
| 100Q | 100-lead, Thin (1.0 mm) Plastic Quad Flat Package (TQFP) | 22 |
| 132Q | 132-lead, Bumpered Plastic Gull Wing Quad Flat Package (BQFP) | 23 |
| 136Q | 136-lead, Plastic Gull Wing Quad Flat Package (PQFP) | 23 |
| 144Q | 144-lead, Plastic Gull Wing Quad Flat Package (PQFP) | 23 |
| 160Q | 160-lead, Plastic Gull Wing Quad Flat Package (PQFP) | 23 |
| 208Q | 208-lead, Plastic Gull Wing Quad Flat Package (PQFP) | 24 |
| 240Q | 240-lead, Plastic Gull Wing Quad Flat Package (PQFP) | 24 |
| 100Q1 | 100-lead Plastic Quad Flat Package (PQFP) | 24 |
| 100Q2 | 100-lead Plastic Quad Flat Package (PQFP) | 24 |
| 304Q | 304Q, 304-lead, Plastic Gull Wing Quad Flat Pack (PQFP) | 25 |
| 28R | 28-lead, 0.330" Wide, Plastic Gull Wing Small Outline (SOIC) | 25 |
| 32R | 32-lead, 0.440" Wide, Plastic Gull Wing Small Outline (SOIC) | 25 |
| 40R | 40-lead, 0.440" Wide, Plastic Gull Wing Small Outline (SOIC) | 25 |
| 44R | 44-lead, 0.525" Wide, Plastic Gull Wing Small Outline (SOIC) | 26 |
| 100RQ | 100-lead, Rectangular Plastic Gull Wing Quad Flat Pack (RQFP) | 26 |
| 14S | 14-lead, 0.150" Wide, Plastic Gull Wing Small Outline (JEDEC SOIC) | 26 |
| 16S | 16-lead, 0.300" Wide, Plastic Gull Wing Small Outline (JEDEC SOIC) | 26 |
| 16S1 | 16-lead, 0.150" Wide, Plastic Gull Wing Small Outline (JEDEC SOIC) | 27 |
| 16S2 | 16-lead, 0.300" Wide, Plastic Gull Wing Small Outline (JEDEC SOIC) | 27 |
| 20S | 20-lead, 0.300" Wide, Plastic Gull Wing Small Outline (SOIC) | 27 |
| 24S | 24-lead, 0.300" Wide, Plastic Gull Wing Small Outline (SOIC) | 27 |
| 28S | 28-lead, 0.300" Wide, Plastic Gull Wing Small Outline (SOIC) | 28 |
| 8S1 | 8-lead, 0.150" Wide, Plastic Gull Wing Small Outline (JEDEC SOIC) | 28 |
| 8S2 | 8-lead, 0.210" Wide, Plastic Gull Wing Small Outline (EIAJ SOIC) | 28 |



| Package | Description | See Page |
|----------------|---|-----------------|
| 8T | 8-lead, Plastic Thin Shrink Small Outline Package (TSSOP) | 28 |
| 14T | 14-lead, 0.170" Wide, Thin Shrink Small Outline Package (TSSOP) | 29 |
| 20T | 20-lead, 0.170" Wide, Thin Shrink Small Outline Package (TSSOP) | 29 |
| 28T | 28-lead, Plastic Thin Small Outline Package (TSOP) | 29 |
| 32T | 32-lead, Plastic Thin Small Outline Package (TSOP) | 29 |
| 40T | 40-lead, Plastic Thin Small Outline Package (TSOP) | 30 |
| 48T | 48-lead, Plastic Thin Small Outline Package (TSOP) | 30 |
| 86T | 86-lead, Plastic Thin Small Outline Package (TSOP) | 30 |
| 28U | 28-pin, Ceramic Pin Grid Array (PGA) | 30 |
| 30U | 30-pin, Ceramic Pin Grid Array (PGA) | 31 |
| 48U | 48-ball, Micro Ball Grid Array Package (μ BGA) | 31 |
| 180U | 180-pin, Ceramic Pin Grid Array (PGA) | 31 |
| 68UW | 68-pin, Ceramic Pin Grid Array (PGA) | 31 |
| 32V | 32-lead, Plastic Thin Small Outline Package (VSOP) | 32 |
| 40V | 40-lead, Plastic Thin Small Outline Package (VSOP) | 32 |
| 20X | 20-lead, 4.4 mm Wide, Plastic Thin Shrink Small Outline (TSSOP) | 32 |
| 24X | 24-lead, 4.4 mm Wide, Plastic Thin Shrink Small Outline (TSSOP) | 32 |
| 20Y | 20-lead, 5.3 mm Wide, Plastic Shrink Small Outline (SSOP) | 33 |



Packaging Information

32A, 32-lead, Low-profile (1.4 mm) Plastic Quad Flat Package (LQFP)
 Dimensions in Millimeters and (Inches)*
 JEDEC STANDARD MS-026 ACB

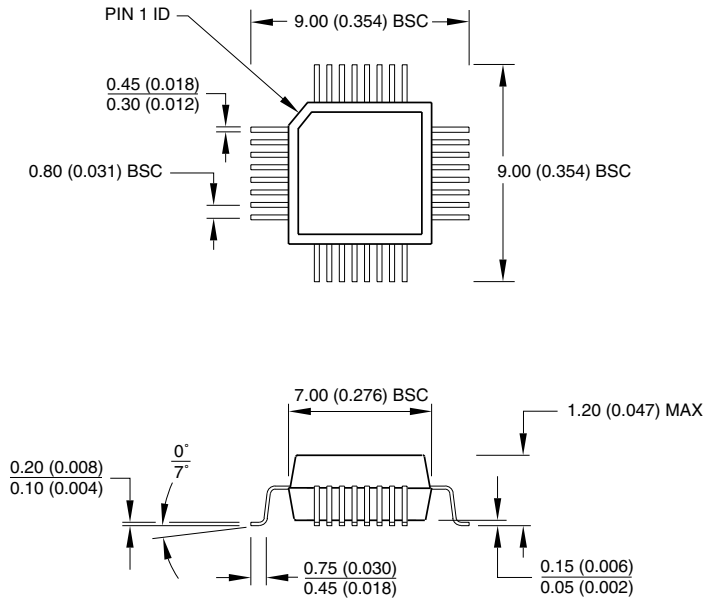

*Controlling dimensions: millimeters

44A, 44-lead, Thin (1.0 mm) Plastic Quad Flat Package (TQFP)
 Dimensions in Millimeters and (Inches)*
 JEDEC STANDARD MS-026 ACB

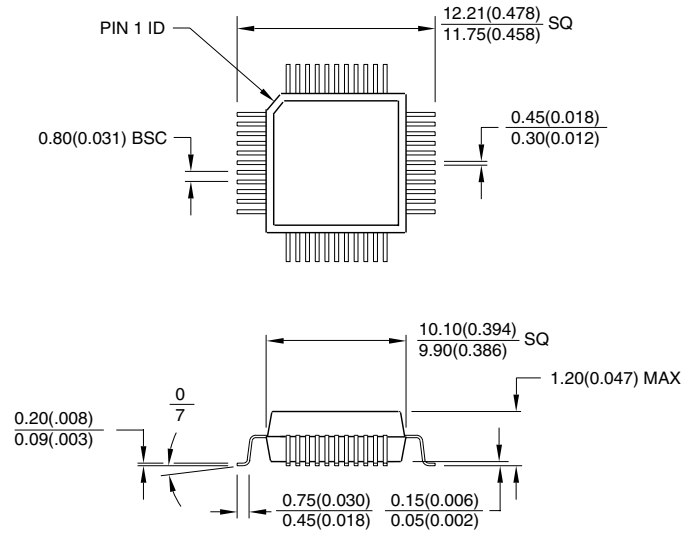

*Controlling dimension: millimeters

48A, 48-lead, Low-profile (1.4 mm) Plastic Quad Flat Package (LQFP)
 Dimensions in Millimeters and (Inches)*
 JEDEC STANDARD MS-026 ACB

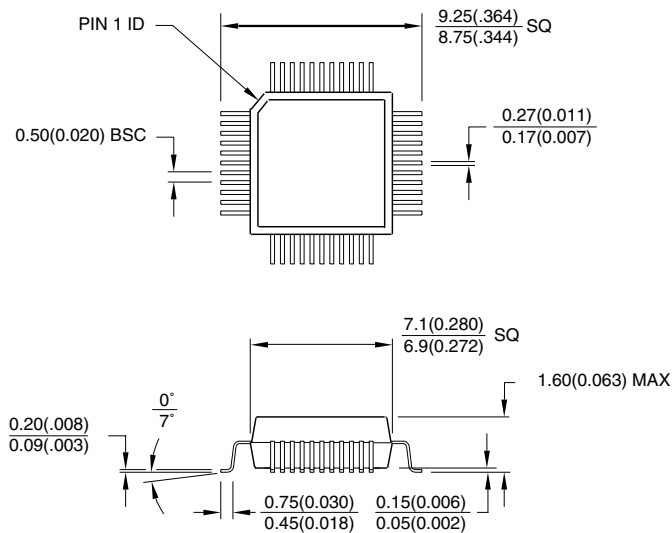

*Controlling dimension: millimeters

64A, 64-lead, Thin (1.0 mm) Plastic Quad Flat Package (TQFP)
 Dimensions in Millimeters and (Inches)*
 JEDEC STANDARD MS-026 AEB

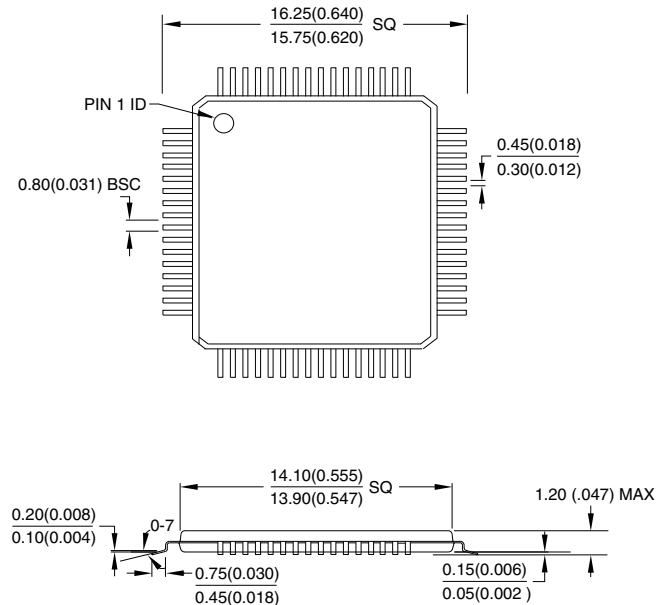

*Controlling dimension: millimeters

Packaging Information

100A, 100-lead, Thin (1.0 mm) Plastic Quad Flat Package (TQFP)

Dimensions in Millimeters and (Inches)*
JEDEC STANDARD MS-026 AED

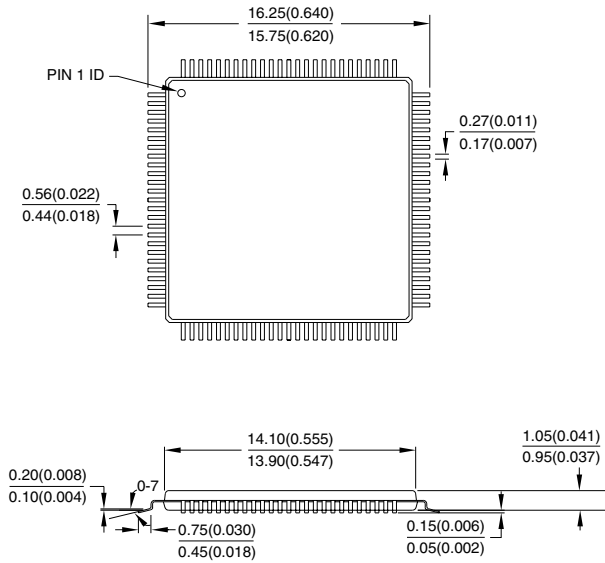

*Controlling dimension: millimeters

144A, 144-lead, Low-profile (1.4 mm) Plastic Quad Flat Package (LQFP)

Dimensions in Millimeters and (Inches)*
JEDEC STANDARD MS-026 BFB

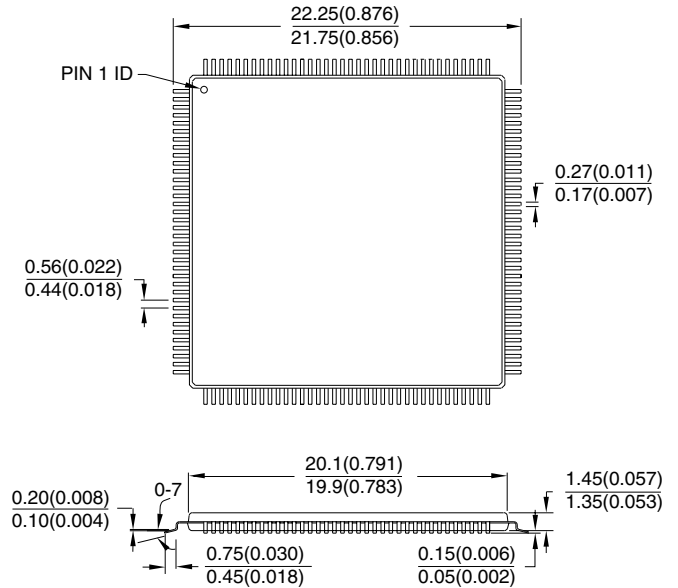

*Controlling dimension: millimeters

32B, 32-lead, 0.600" Wide, Ceramic Side Braze Dual Inline (Side Braze)

Dimensions in Inches and (Millimeters)
MIL-STD-1835 D-16 CONFIG C

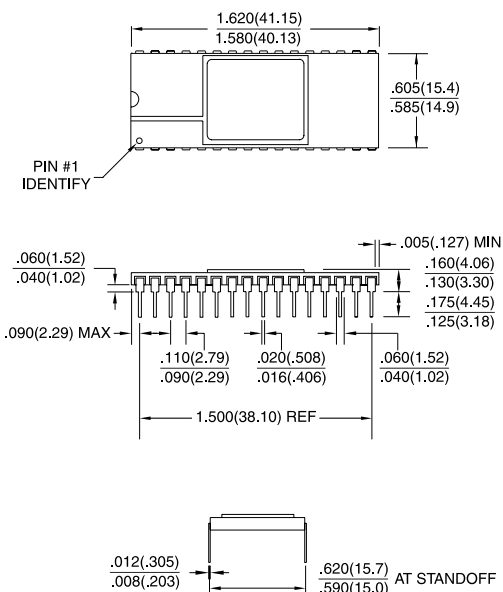

40B, 40-lead, 0.600" Wide, Ceramic Side Braze Dual Inline (Side Braze)

Dimensions in Inches and (Millimeters)
MIL-STD-1835 D-5 CONFIG C

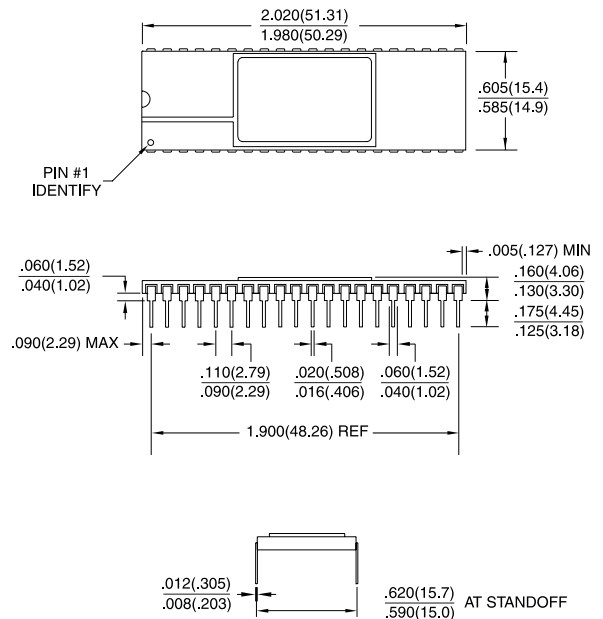

Packaging Information

352B, 352-ball Ball Grid Array (BGA)
Dimensions in (Millimeters) and Inches

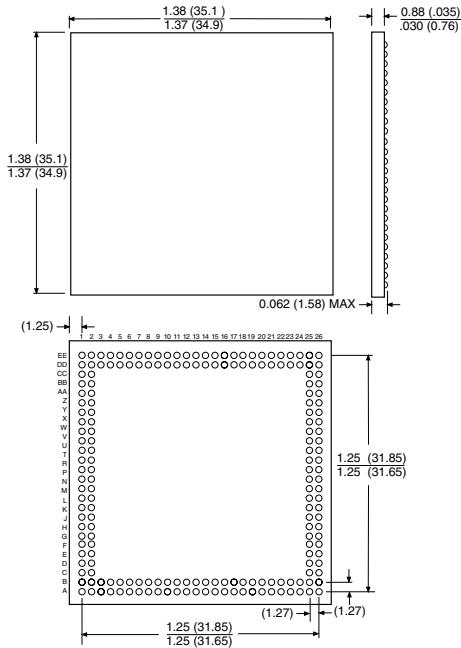

432B, 432-ball Ball Grid Array (BGA)
Dimensions in (Millimeters) and Inches

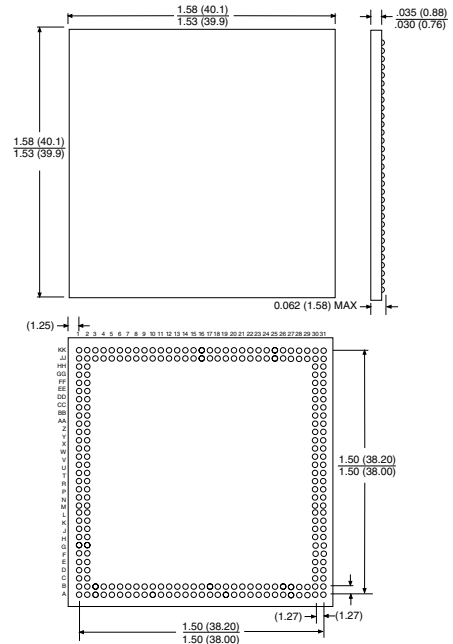

8C, 8-lead, 0.230" Wide, Leadless Array Package (LAP)
Dimensions in Millimeters and (Inches)*

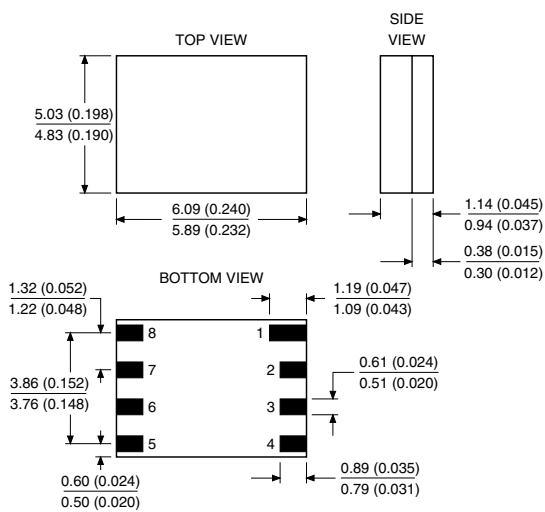

* Controlling dimension: millimeters

8C1, 8-lead 0.300" Wide, Leadless Array Package (LAP)
Dimensions in Millimeters and (Inches)*

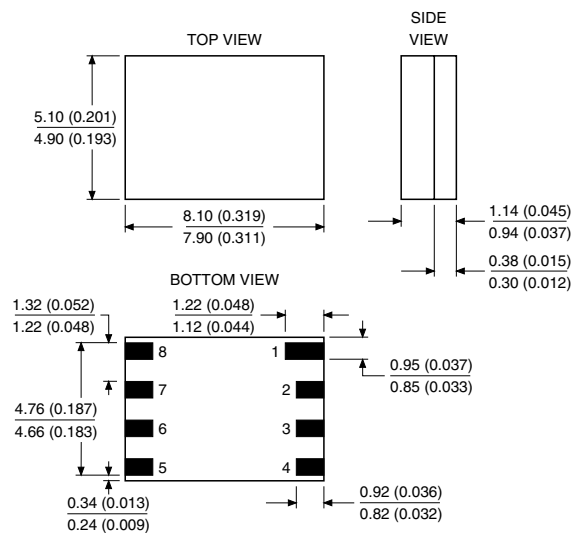

* Controlling dimension: millimeters

Packaging Information

14C1, 14-ball (3 x 5 array) 1.0 mm Pitch,
4.5 x 7.0 mm Plastic Chip-scale Ball Grid
Array (CBGA)
Dimensions in Millimeters and (Inches)*

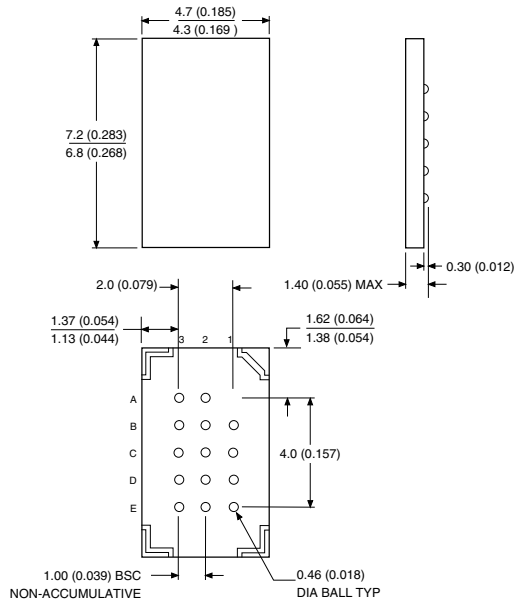

* Controlling dimension: millimeters

24C1, 24-ball (5 x 5 Array), 1.0 mm Pitch, 8 x 6 mm
Plastic Chip-scale Ball Grid Array Package (CBGA)
Dimensions in Millimeters and (Inches)*

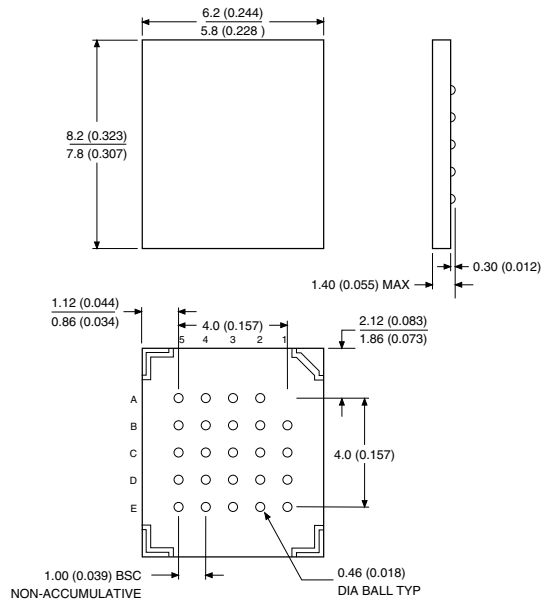

* Controlling dimension: millimeters

24C2, 24-ball (5 x 5 Array), 1.0 mm Pitch, 7 x 9.5 mm
Plastic Chip-scale Ball Grid Array Package (CBGA)
Dimensions in Millimeters and (Inches)*

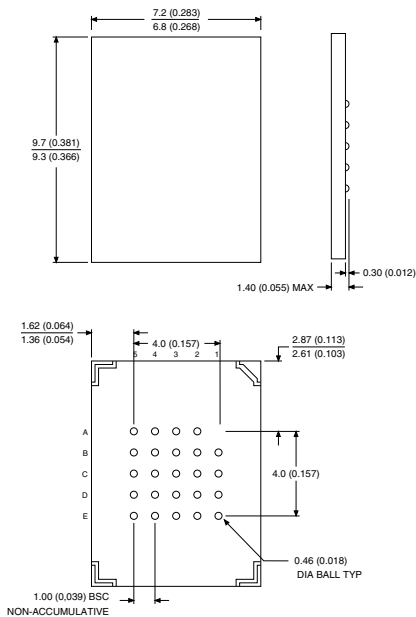

* Controlling dimension: millimeters

24C3, 24-Ball (5 x 5 array), 1.0 mm Pitch,
Plastic Chip-scale Ball Grid Array (CBGA)
Dimensions in Millimeters and (Inches)*

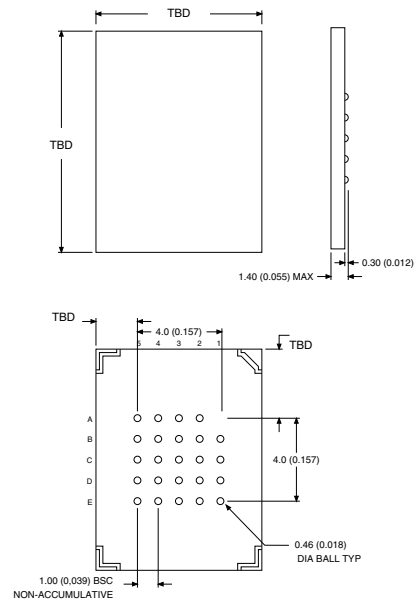

* Controlling dimension: millimeters

Packaging Information

42C1, 42-ball (7 x 6 Array), 1.0 mm Pitch, 8 x 8 mm Plastic Chip-scale Ball Grid Array Package (CBGA)
Dimensions in Millimeters and (Inches)*

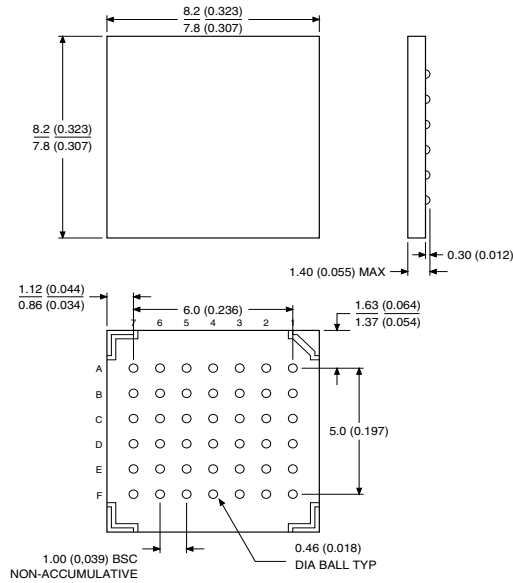

*Controlling dimension: millimeters

42C2, 42-ball (7 x 6 Array), 1.0 mm Pitch, 8 x 14 mm Plastic Chip-scale Ball Grid Array Package (CBGA)
Dimensions in Millimeters and (Inches)*

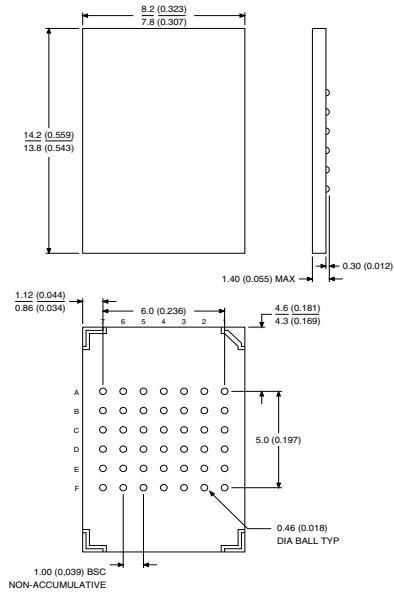

*Controlling dimension: millimeters

44C1, 44-ball (5 x 9 array), 1.0 mm Pitch, Plastic Chip-scale Ball Grid Array (CBGA)
Dimensions in Millimeters and (Inches)*

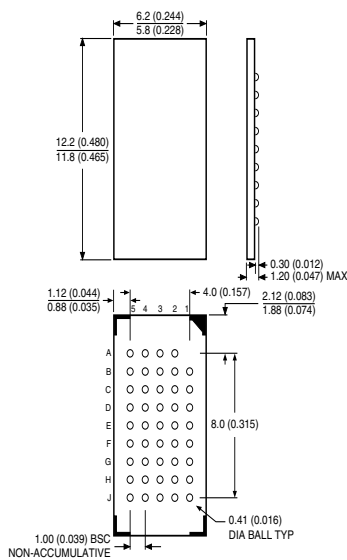

*Controlling dimension: millimeters

48C1, 48-ball (8 x 6 Array), 0.75 mm Pitch, 7 x 7 mm Plastic Chip-scale Ball Grid Array Package (CBGA)
Dimensions in Millimeters and (Inches)*

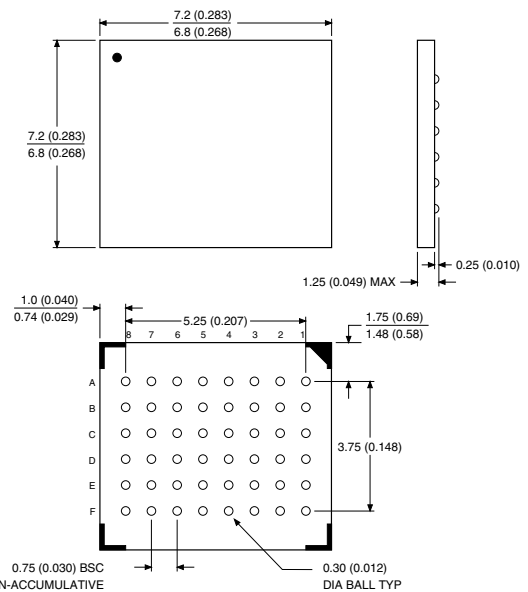

*Controlling dimension: millimeters

Packaging Information

48C2, 48-ball (6 x 8 Array), 0.80 mm Pitch, 8 x 10 mm Plastic Chip-scale Ball Grid Array Package (CBGA)
Dimensions in Millimeters and (Inches)*

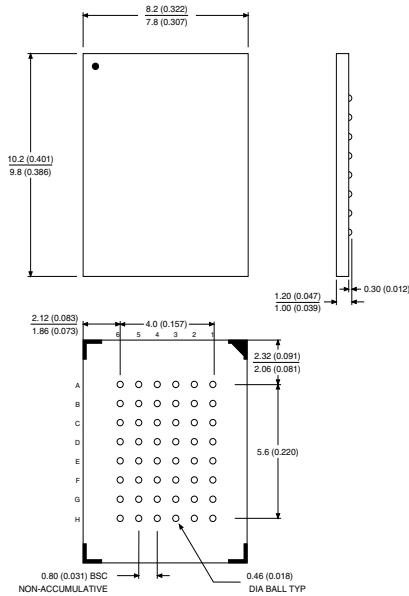

*Controlling dimension: millimeters

48C3, 48-ball (6 x 8 Array), 0.80 mm Pitch, 7 x 7 mm Plastic Chip-scale Ball Grid Array Package (CBGA)
Dimensions in Millimeters and (Inches)*

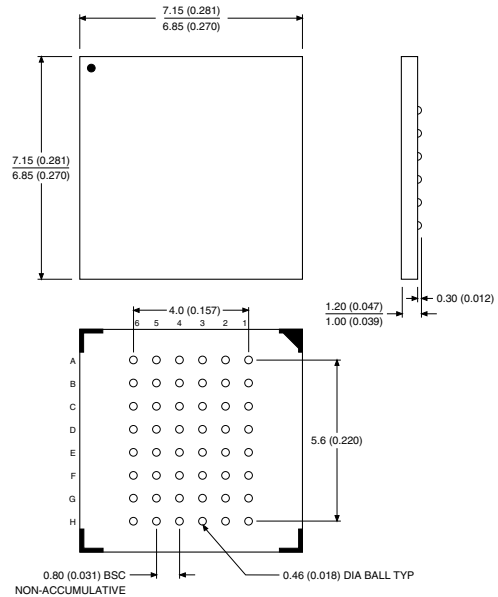

*Controlling dimension: millimeters

72C1, 72-ball (12 x 6 Array), 1.0 mm Pitch, 13 x 9 mm Plastic Chip-scale Ball Grid Array Package (CBGA)
Dimensions in Millimeters and (Inches)*

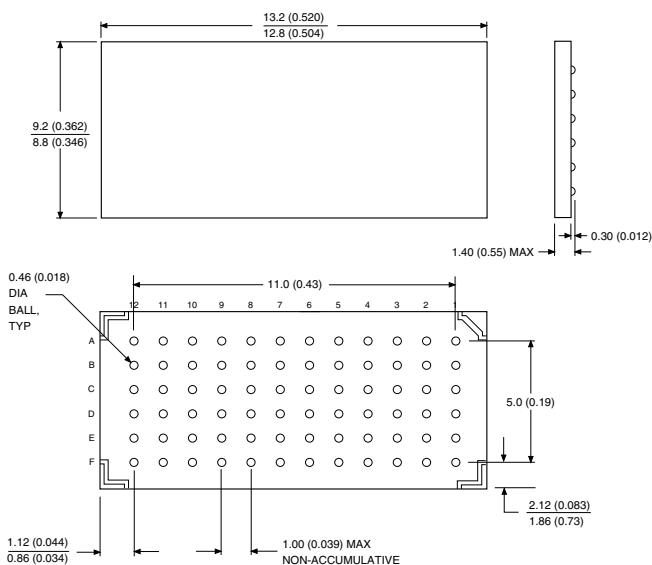

*Controlling dimension: millimeters

120C1, 120-ball (17 x 17 Array), 1.0 Pitch, 19 x 19 mm Ceramic Multi-die Ball Grid Array Package (CerMBGA)
Dimensions in Millimeters and (Inches)*

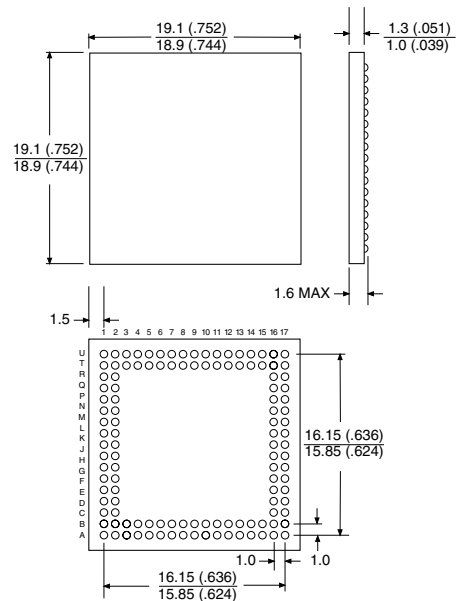

*Controlling dimension: millimeters

Packaging Information

16D3, 16-lead, 0.300" Wide, Non-windowed,
Ceramic Dual Inline Package (Cerdip)
Dimensions in Inches and (Millimeters)
MIL-STD-1835 D-2 CONFIG A

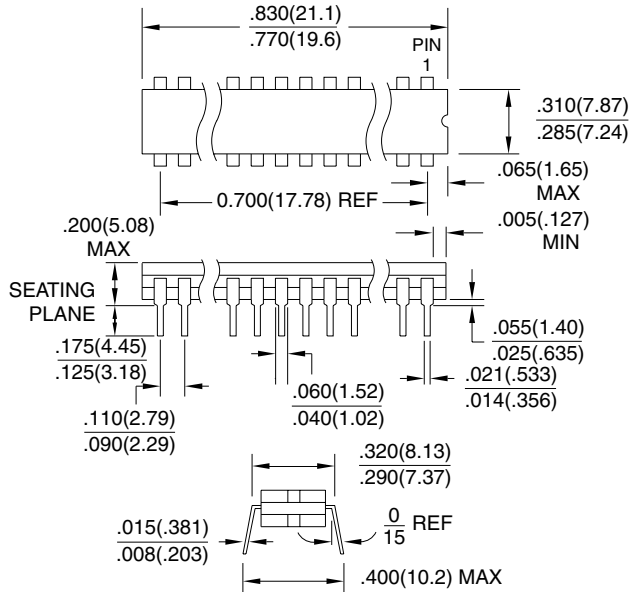

20D3, 20-lead, 0.300" Wide, Non-windowed,
Ceramic Dual Inline Package (Cerdip)
Dimensions in Inches and (Millimeters)
MIL-STD-1835 D-8 CONFIG A

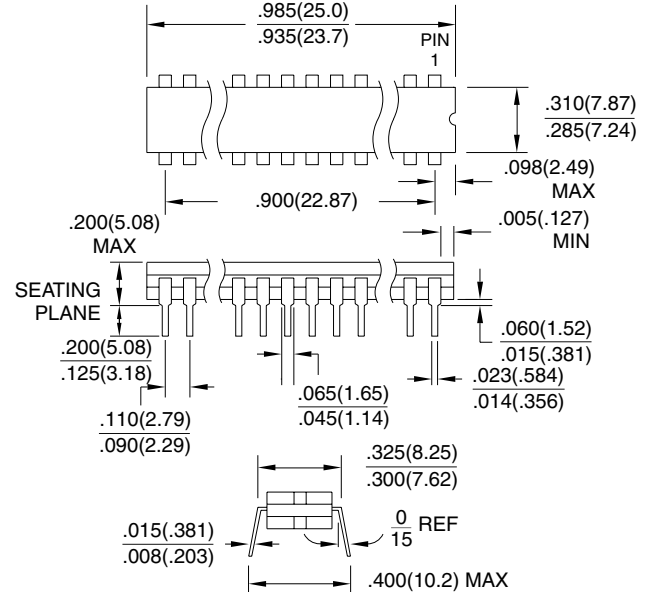

24D3, 24-lead, 0.300" Wide, Non-windowed,
Ceramic Dual Inline Package (Cerdip)
Dimensions in Inches and (Millimeters)
MIL-STD-1835 D-9 CONFIG A

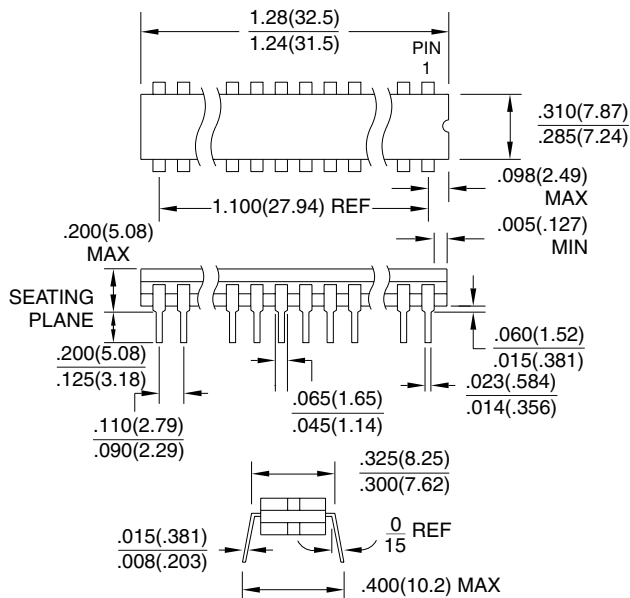

24D6, 24-lead, 0.600" Wide, Non-windowed,
Ceramic Dual Inline Package (Cerdip)
Dimensions in Inches and (Millimeters)
MIL-STD-1835 D-3 CONFIG A

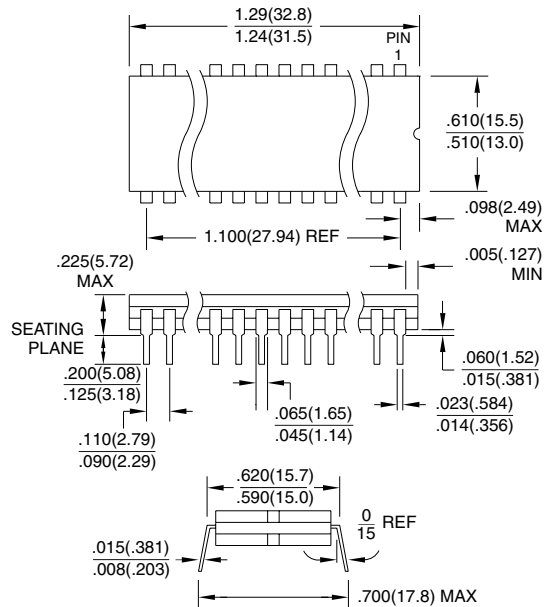

Packaging Information

28D6, 28-lead, 0.600" Wide, Non-windowed, Ceramic Dual Inline Package (Cerdip)
 Dimensions in Inches and (Millimeters)
 MIL-STD-1835 D-10 CONFIG A

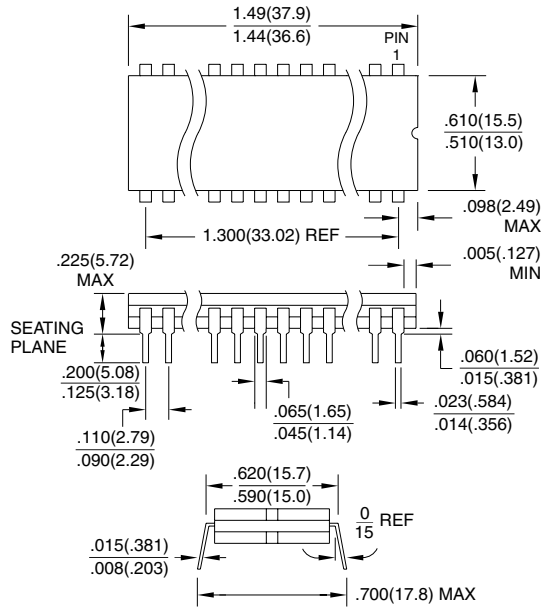

32D6, 32-lead, 0.600" Wide, Non-windowed, Ceramic Dual Inline Package (Cerdip)
 Dimensions in Inches and (Millimeters)
 MIL-STD-1835 D-16 CONFIG A

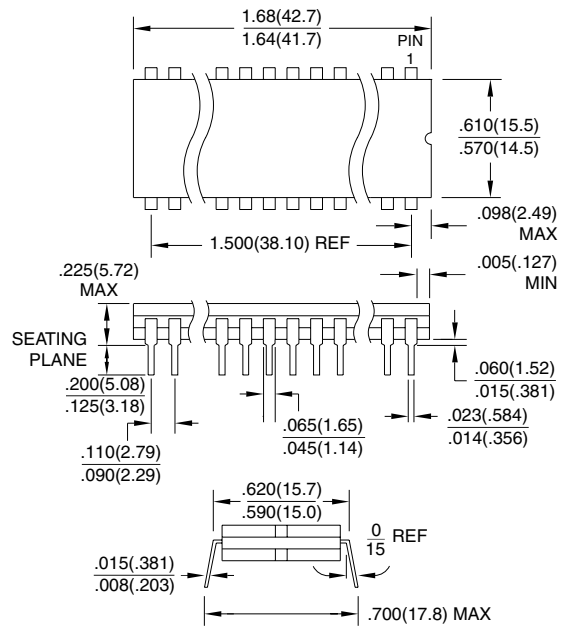

40D6, 40-lead, 0.600" Wide, Non-windowed, Ceramic Dual Inline Package (Cerdip)
 Dimensions in Inches and (Millimeters)
 MIL-STD-1835 D-5 CONFIG A

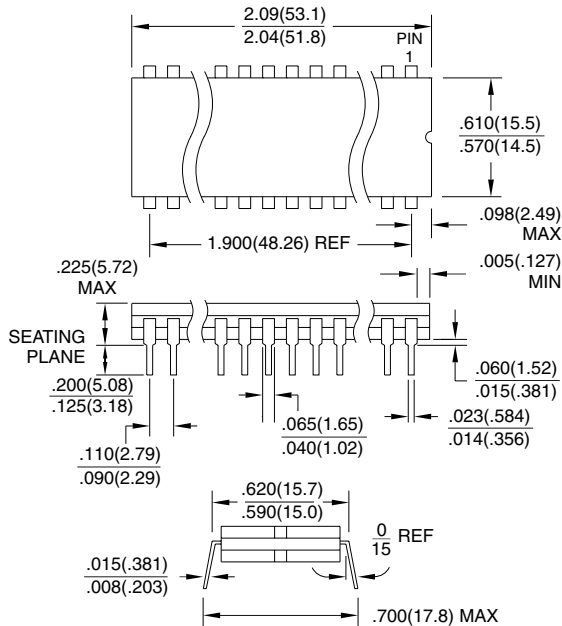

24DW3, 24-lead, 0.300" Wide, Windowed, Ceramic Dual Inline Package (Cerdip)
 Dimensions in Inches and (Millimeters)
 MIL-STD-1835 D-9 CONFIG A

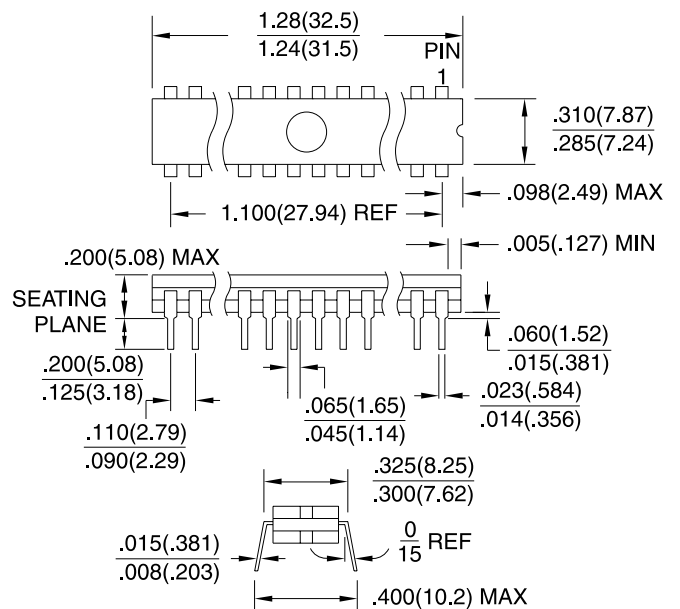

Packaging Information

24DW6, 24-lead, 0.600" Wide, Windowed, Ceramic Dual Inline Package (Cerdip)
 Dimensions in Inches and (Millimeters)
 MIL-STD-1835 D-3 CONFIG A

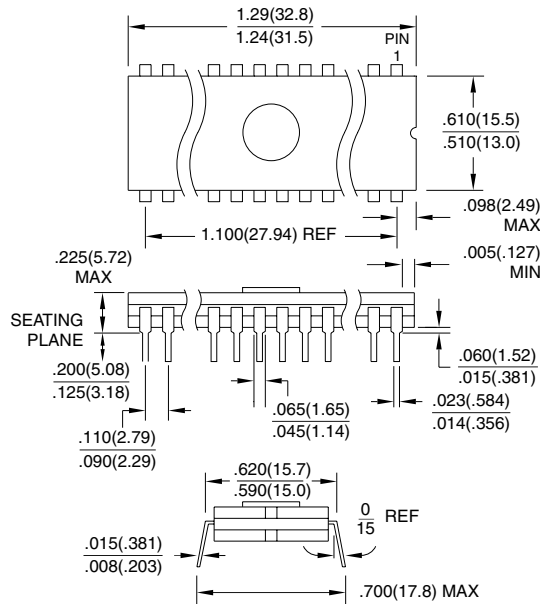

28DW6, 28-lead, 0.600" Wide, Windowed, Ceramic Dual Inline Package (Cerdip)
 Dimensions in Inches and (Millimeters)
 MIL-STD-1835 D-10 CONFIG A

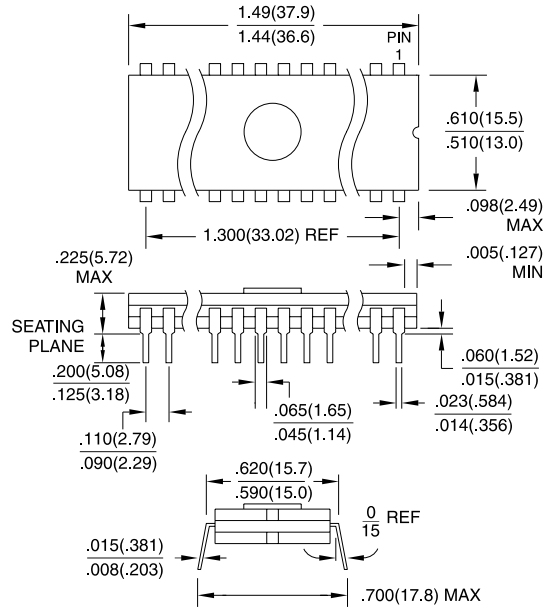

32DW6, 32-lead, 0.600" Wide, Windowed, Ceramic Dual Inline Package (Cerdip)
 Dimensions in Inches and (Millimeters)
 MIL-STD-1835 D-16 CONFIG A

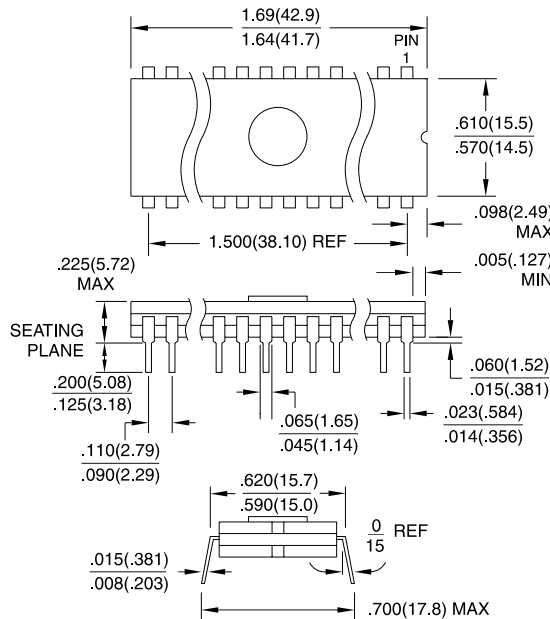

40DW6, 40-lead, 0.600" Wide, Windowed, Ceramic Dual Inline Package (Cerdip)
 Dimensions in Inches and (Millimeters)
 MIL-STD-1835 D-5 CONFIG A

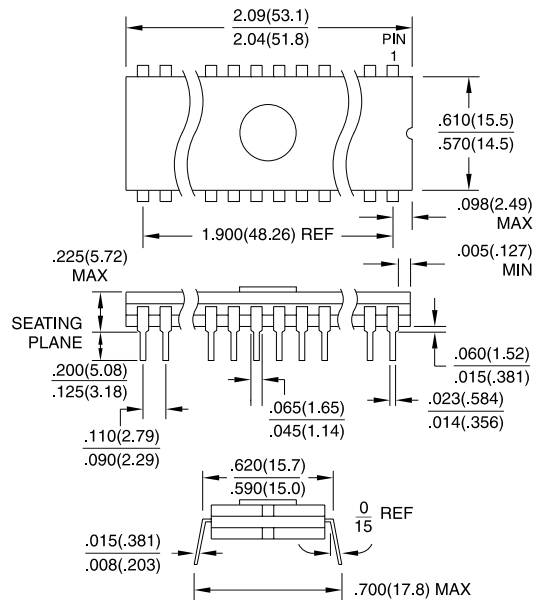

Packaging Information

42DW6, 42-lead, 0.600" Wide, Windowed, Ceramic Dual In-line Package (Cerdip)
 Dimensions in Inches and (Millimeters)

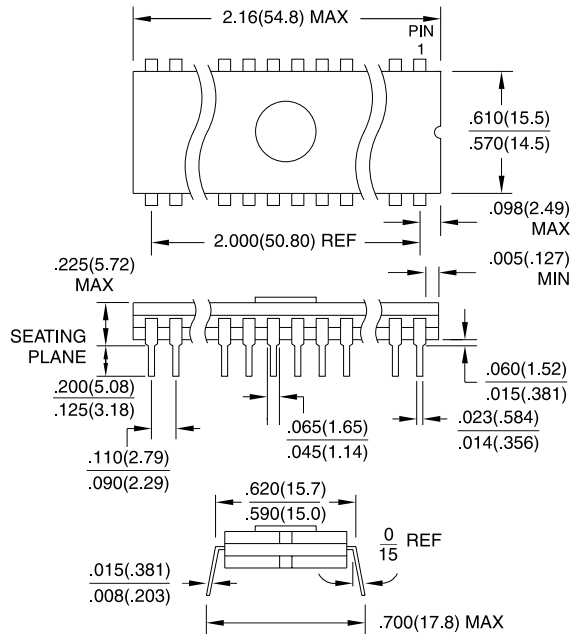

28F, 28-lead, Non-windowed, Ceramic Bottom-Brazed Flat Package (Flatpack)
 Dimensions in Inches (Millimeters)
 MIL-STD-1835 F-12 CONFIG B

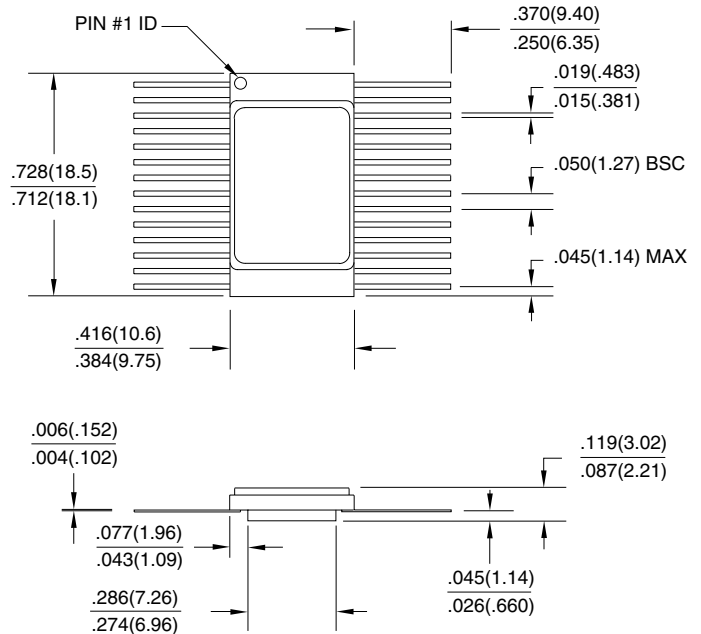

32F, 32-lead, Non-windowed, Ceramic Bottom-Brazed Flat Package (Flatpack)
 Dimensions in Inches and (Millimeters)
 MIL-STD-1835 F-18 CONFIG B
 JEDEC OUTLINE MO-115

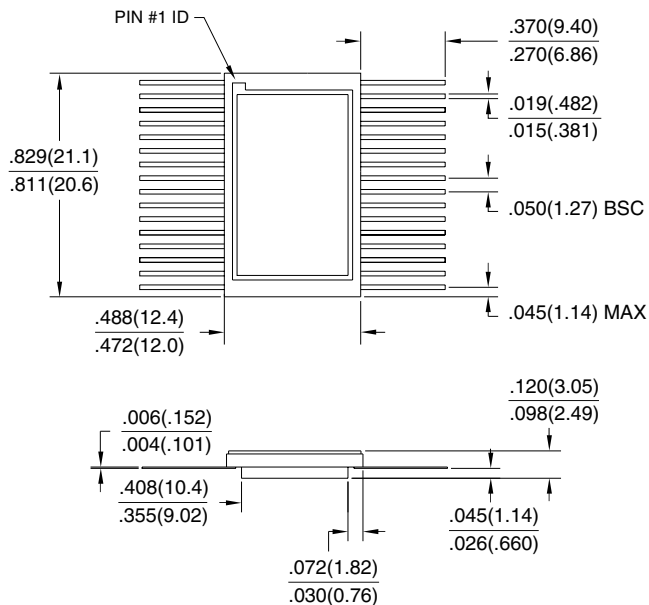

20J, 20-lead, Plastic J-leaded Chip Carrier (PLCC)
 Dimensions in Inches and (Millimeters)
 JEDEC STANDARD MS-018 AA

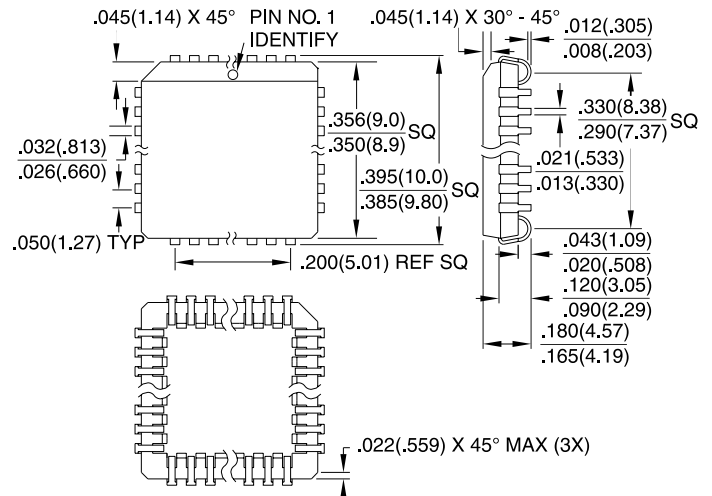

Packaging Information

28J, 28-lead, Plastic J-leaded Chip Carrier (PLCC)
 Dimensions in Inches and (Millimeters)
 JEDEC STANDARD MS-018 AB

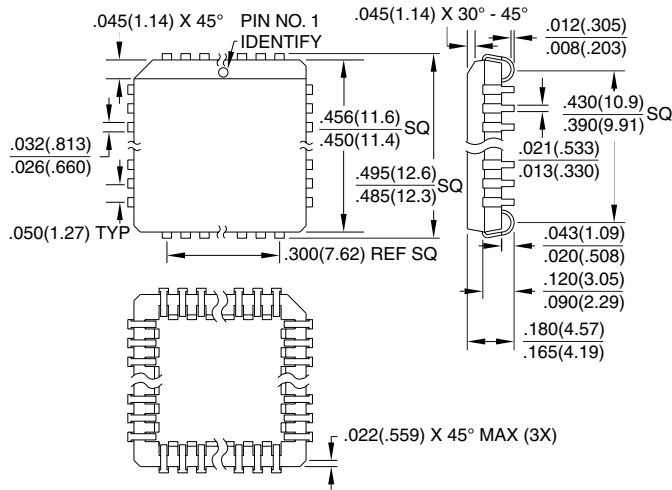

32J, 32-lead, Plastic J-leaded Chip Carrier (PLCC)
 Dimensions in Inches and (Millimeters)
 JEDEC STANDARD MS-016 AE

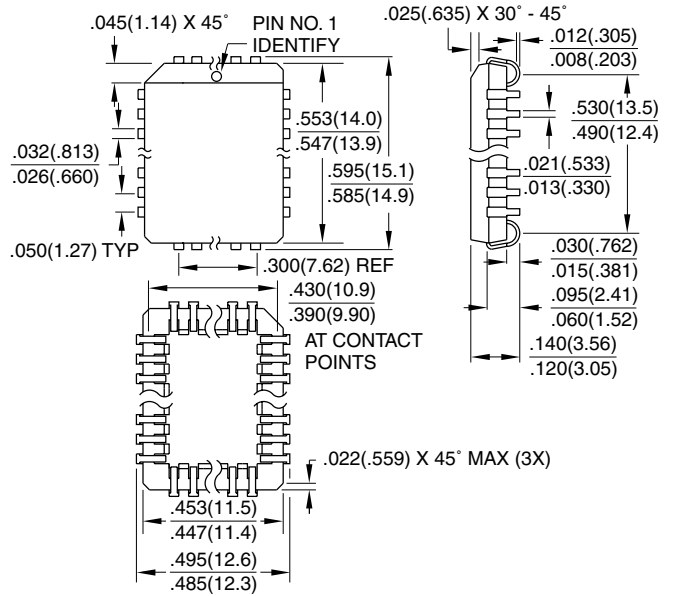

44J, 44-lead, Plastic J-leaded Chip Carrier (PLCC)
 Dimensions in Inches and (Millimeters)
 JEDEC STANDARD MS-018 AC

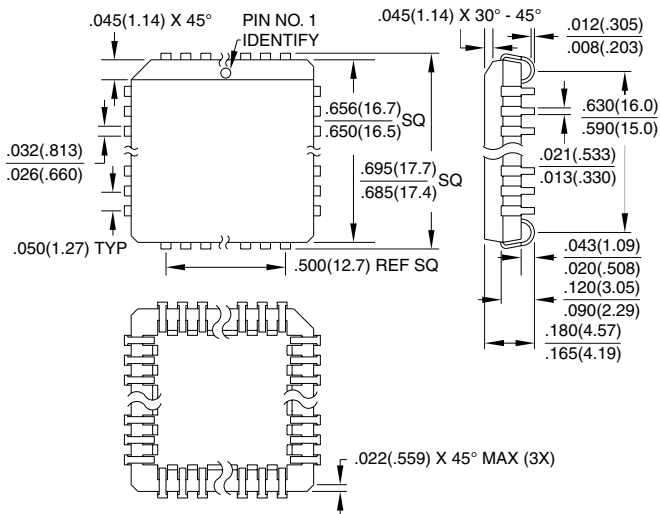

68J, 68-lead, Plastic J-leaded Chip Carrier (PLCC)
 Dimensions in Inches and (Millimeters)
 JEDEC STANDARD MS-018 AE

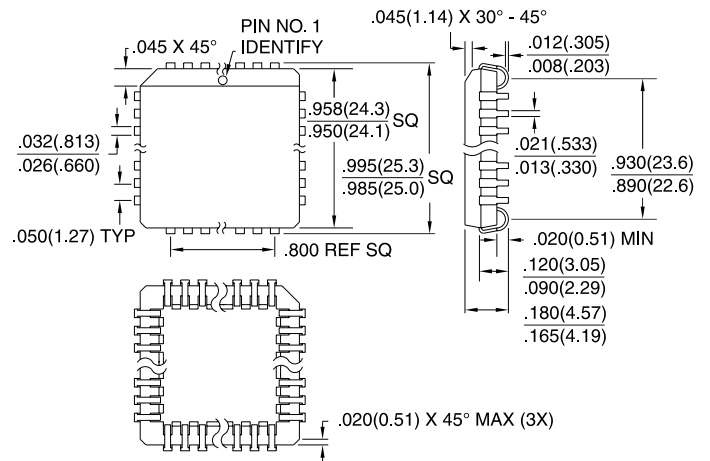

Packaging Information

84J, 84-lead, Plastic J-led Chip Carrier (PLCC)
 Dimensions in Inches and (Millimeters)
 JEDEC STANDARD MS-018 AF

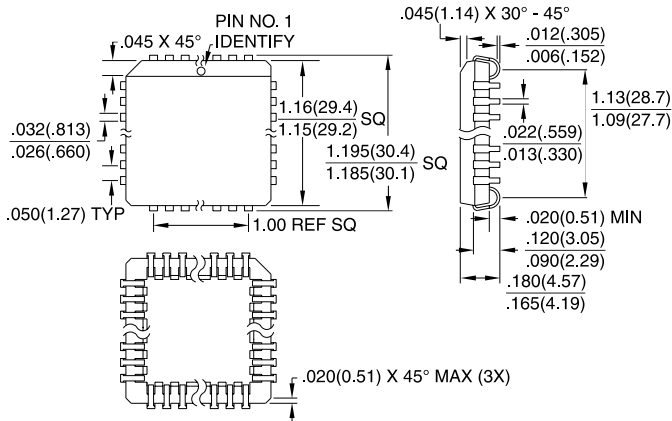

32K, 32-lead, Non-windowed, Ceramic J-led Chip Carrier (JLCC)
 Dimensions in Inches and (Millimeters)

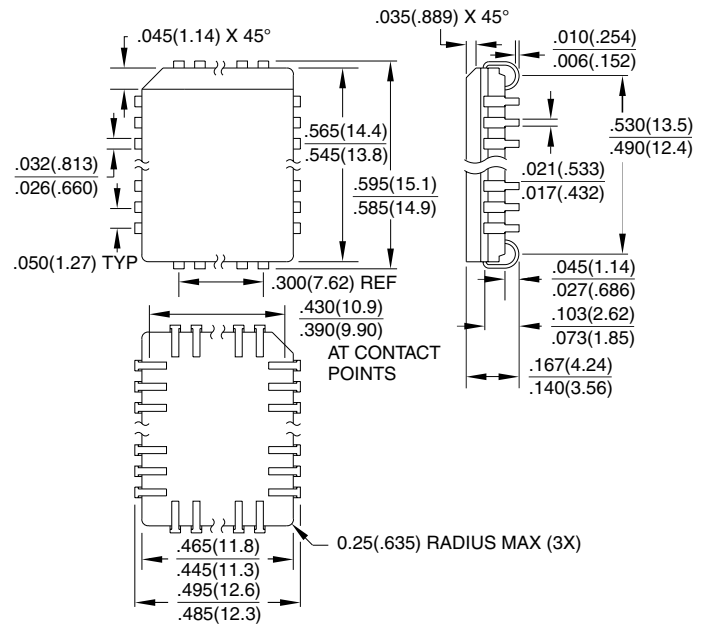

44K, 44-lead, Non-windowed, Ceramic J-led Chip Carrier (JLCC)
 Dimension in Inches and (Millimeters)

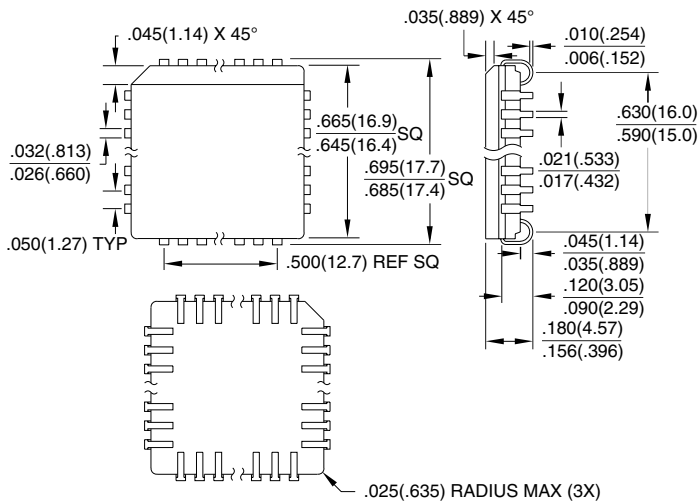

28KW, 28-lead, Windowed, Ceramic J-led Chip Carrier (JLCC)
 Dimensions in Inches and (Millimeters)
 MIL-STD-1835 C-J7
 JEDEC OUTLINE MO-087 AA

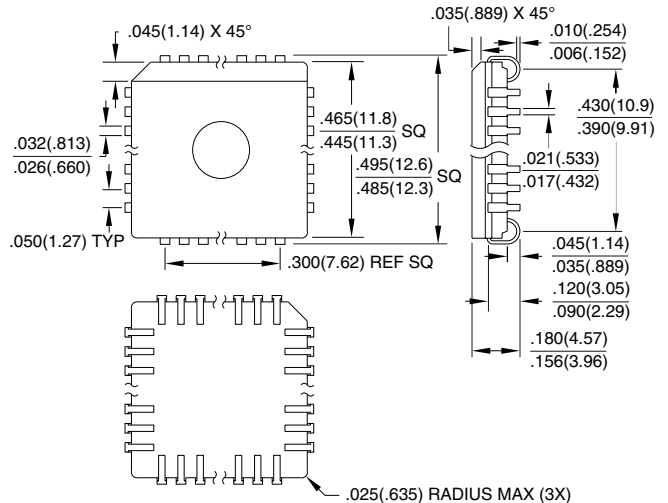

Packaging Information

32KW, 32-lead, Windowed, Ceramic J-led Chip Carrier (JLCC)
Dimensions in Inches and (Millimeters)

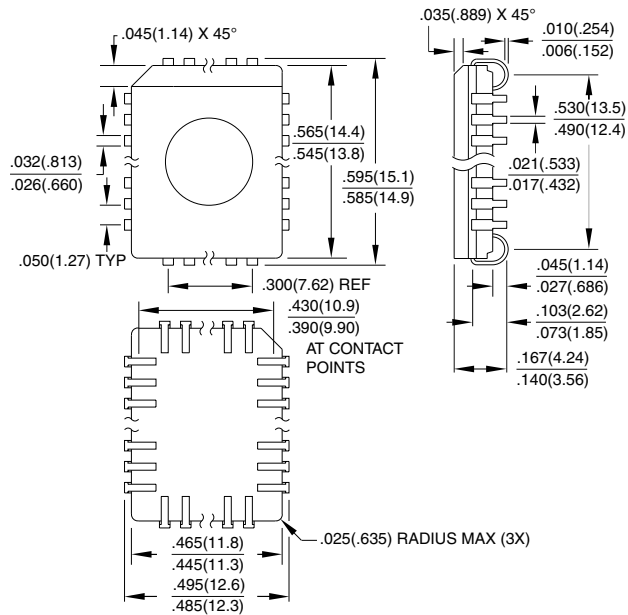

44KW, 44-lead, Windowed, Ceramic J-led Chip Carrier (JLCC)
Dimensions in Inches and (Millimeters)
MIL-STD-1835 CJ1

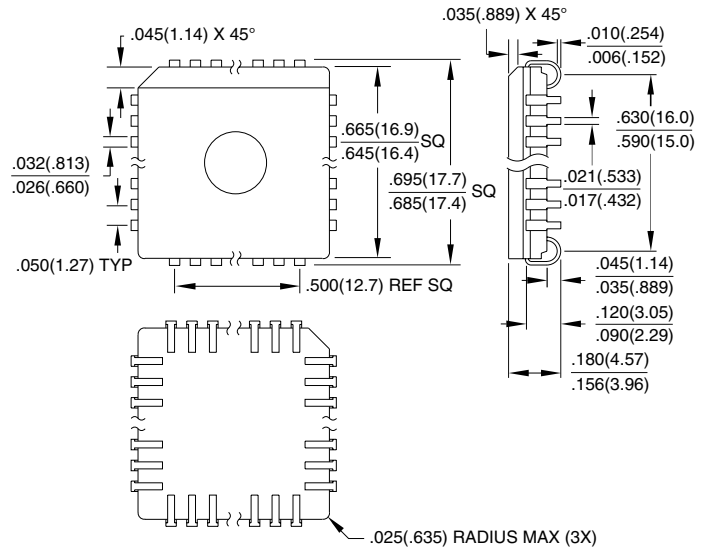

68KW, 68-lead, Windowed, Ceramic J-led Chip Carrier (JLCC)
Dimensions in Inches and (Millimeters)
MIL-STD-1835 C-J2
JEDEC OUTLINE MO-087 AD

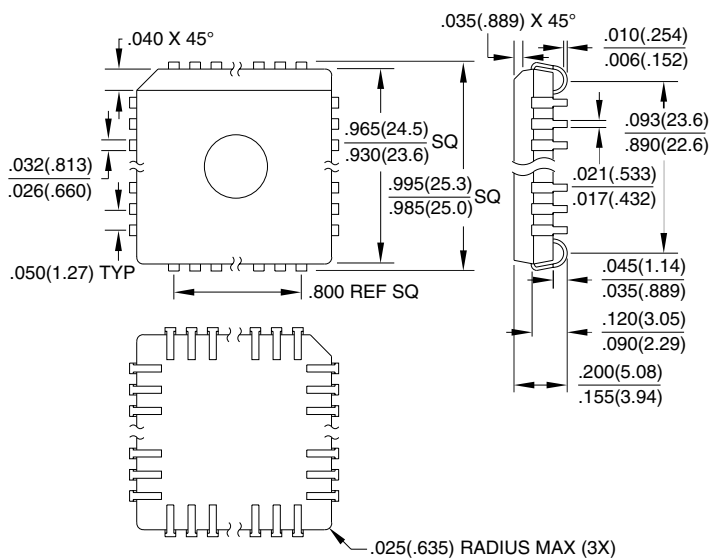

20L, 20-pad, Non-windowed, Ceramic Leadless Chip Carrier (LCC)
Dimensions in Inches and (Millimeters)
MIL-STD-1835 C-2

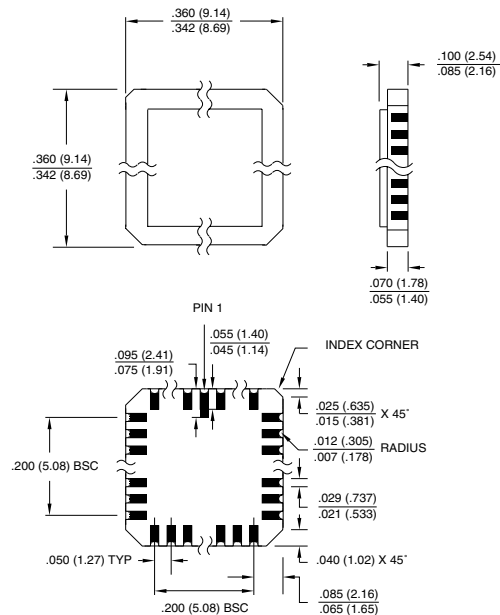

Packaging Information

28L, 28-pad, Non-windowed, Ceramic Leadless Chip Carrier (LCC)

Dimensions in Inches and (Millimeters)
MIL-STD-1835 C-4

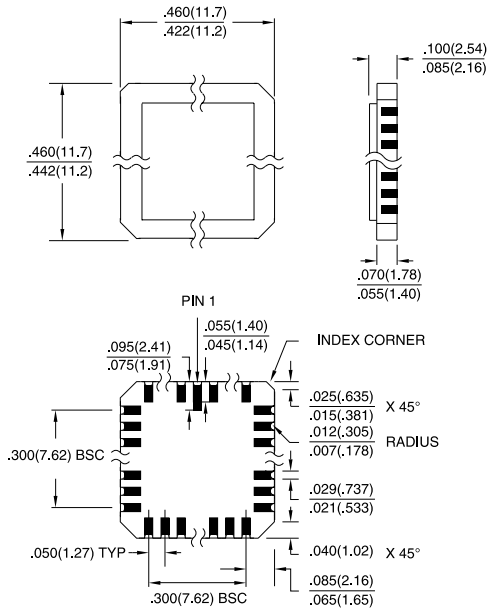

32L, 32-pad, Non-windowed, Ceramic Leadless Chip Carrier (LCC)

Dimensions in Inches and (Millimeters)
MIL-STD-1835 C-12

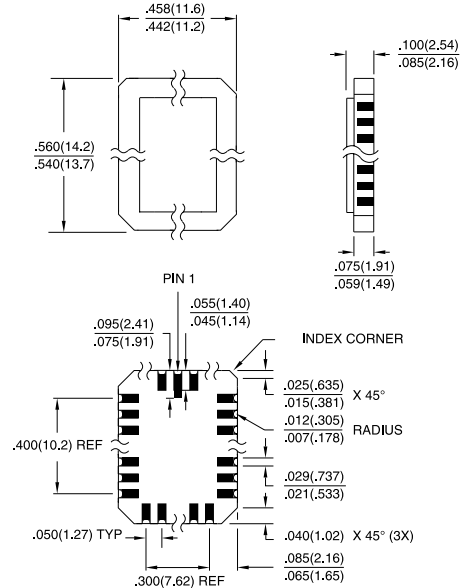

44L, 44-pad, Non-windowed, Ceramic Leadless Chip Carrier (LCC)

Dimensions in Inches and (Millimeters)
MIL-STD-1835 C-5

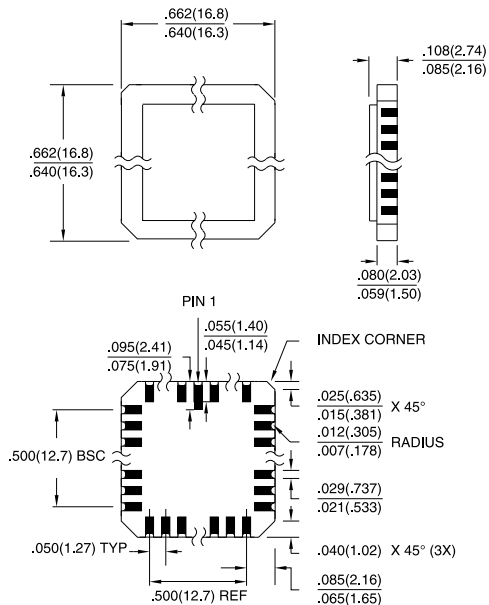

28LW, 28-pad, Windowed, Ceramic Leadless Chip Carrier (LCC)

Dimensions in Inches and (Millimeters)
MIL-STD-1835 C-4

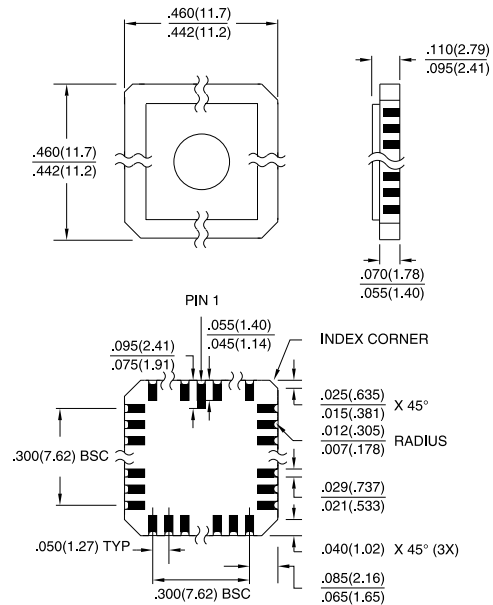

Packaging Information

32LW, 32-pad, Windowed, Ceramic Leadless Chip Carrier (LCC)

Dimensions in Inches and (Millimeters)
MIL-STD-1835 C-12

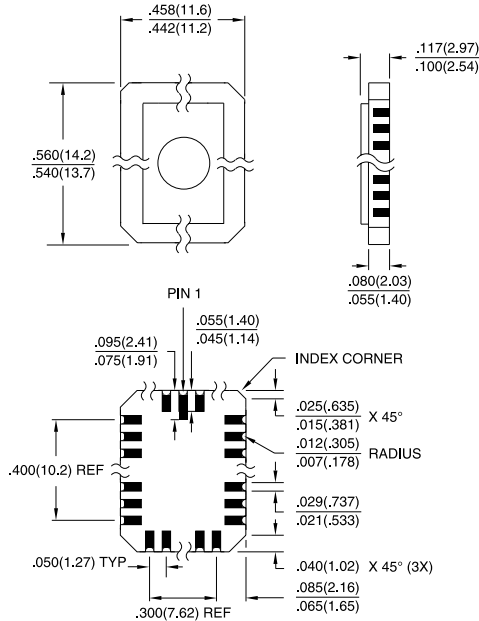

44LW, 44-pad, Windowed, Ceramic Leadless Chip Carrier (LCC)

Dimensions in Inches and (Millimeters)
MIL-STD-1835 C-5

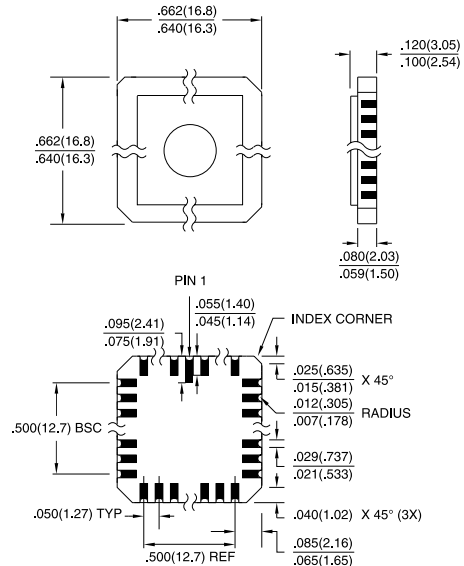

8M, 8-lead, 0.118" Wide, Miniature Small Outline (MSOP)

Dimensions in Millimeters and (Inches)*

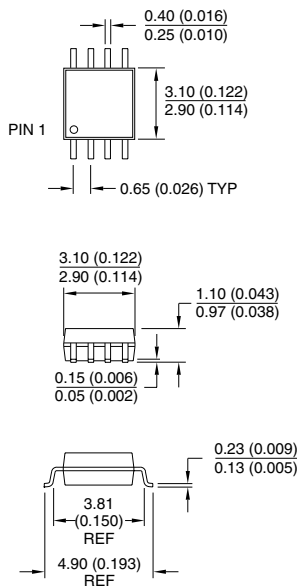

* Controlling dimension: millimeters

48M1, 48-ball, (8 x 6 Array), 0.75 mm Pitch, Micro Ball Grid Array (µBGA)

Dimensions in Millimeters and (Inches)*

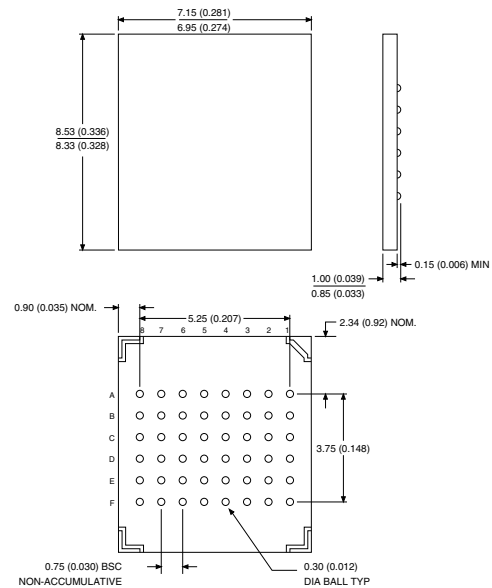

* Controlling dimension: millimeters

Packaging Information

8P3, 8-lead, 0.300" Wide, Plastic Dual Inline Package (PDIP)

Dimensions in Inches and (Millimeters)

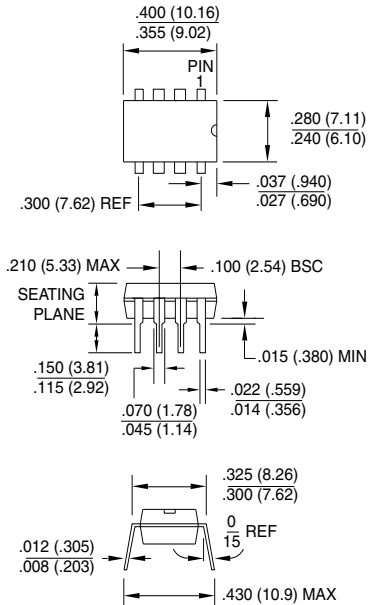

16P3, 16-lead, 0.300" Wide, Plastic Dual Inline Package (PDIP)

Dimensions in Inches and (Millimeters)

JEDEC STANDARD MS-001 BB

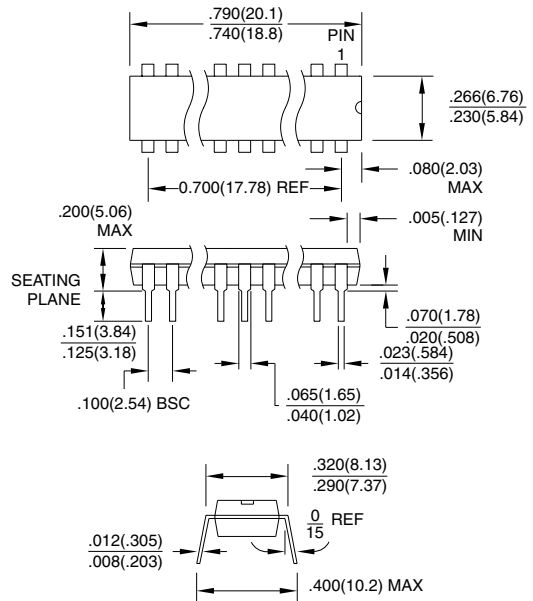

20P3, 20-lead, 0.300" Wide, Plastic Dual Inline Package (PDIP)

Dimensions in Inches and (Millimeters)

JEDEC STANDARD MS-001 AD

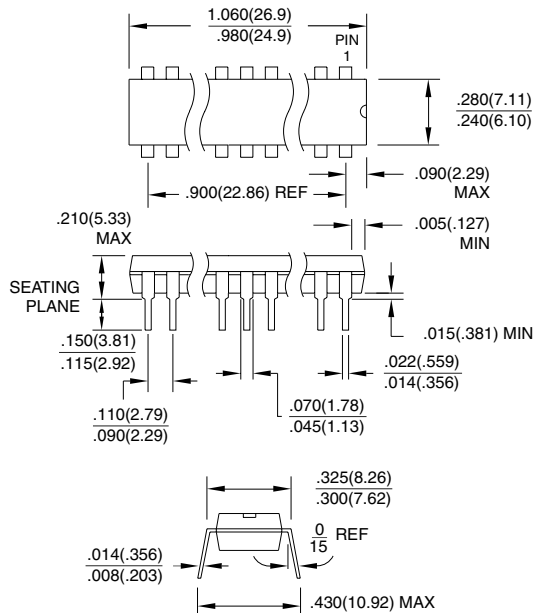

24P3, 24-lead, 0.300" Wide, Plastic Dual Inline Package (PDIP)

Dimensions in Inches and (Millimeters)

JEDEC STANDARD MS-001 AF

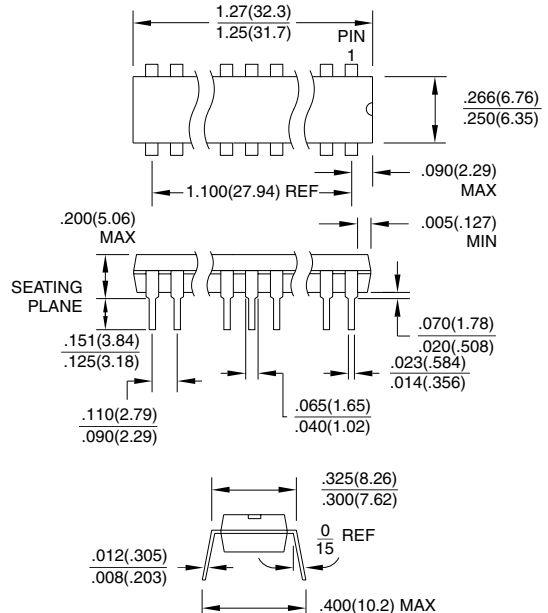

Packaging Information

28P3, 28-lead, 0.300" Wide, Plastic Dual Inline Package (PDIP)

Dimensions in Inches and (Millimeters)

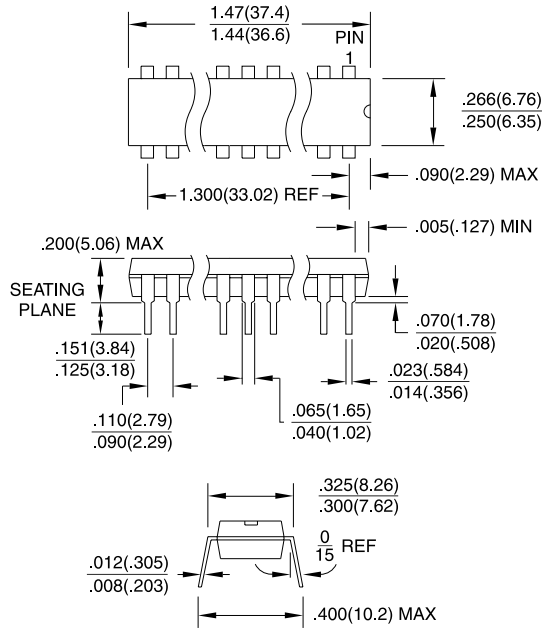

24P6, 24-lead, 0.600" Wide, Plastic Dual Inline Package (PDIP)

Dimensions in Inches and (Millimeters)

JEDEC STANDARD MS-011 AA

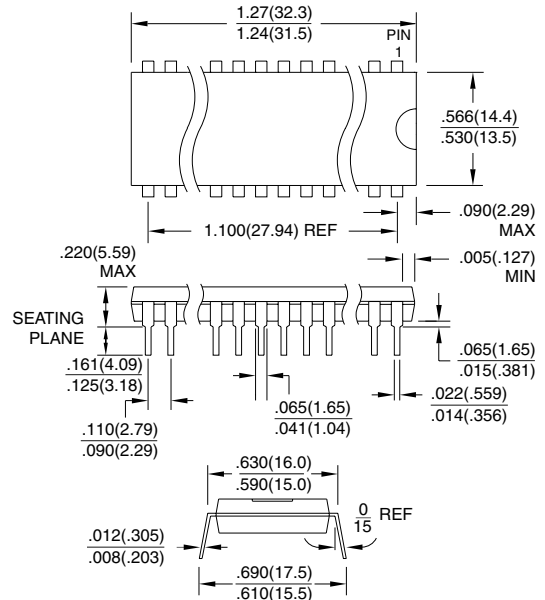

28P6, 28-lead, 0.600" Wide, Plastic Dual Inline Package (PDIP)

Dimensions in Inches and (Millimeters)

JEDEC STANDARD MS-011 AB

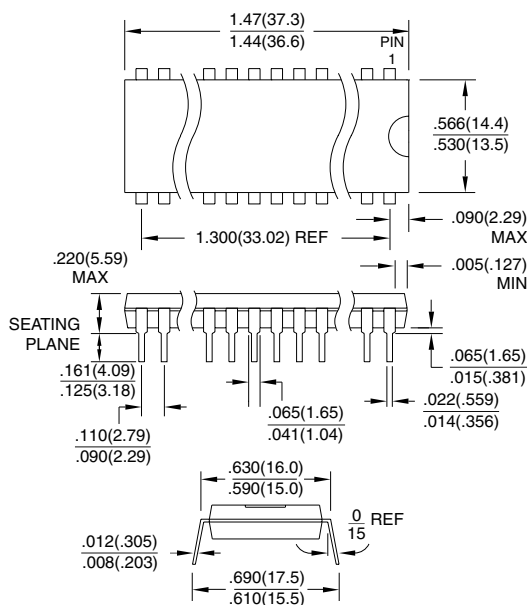

32P6, 32-lead, 0.600" Wide, Plastic Dual Inline Package (PDIP)

Dimensions in Inches and (Millimeters)

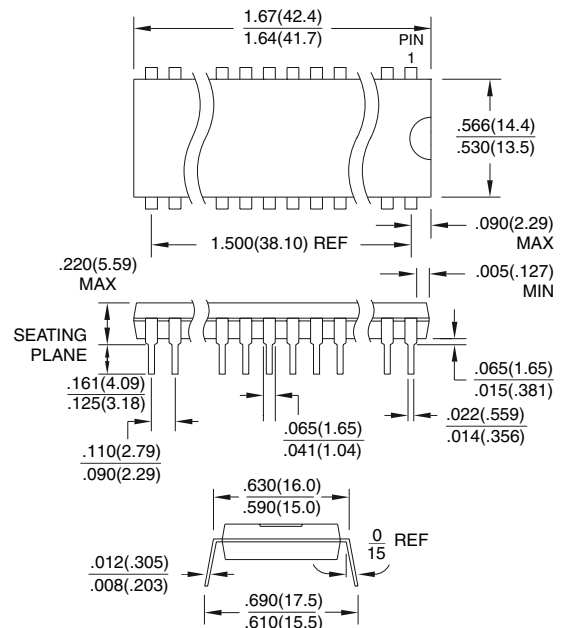

Packaging Information

40P6, 40-lead, 0.600" Wide, Plastic Dual Inline Package (PDIP)

Dimensions in Inches and (Millimeters)
JEDEC STANDARD MS-011 AC

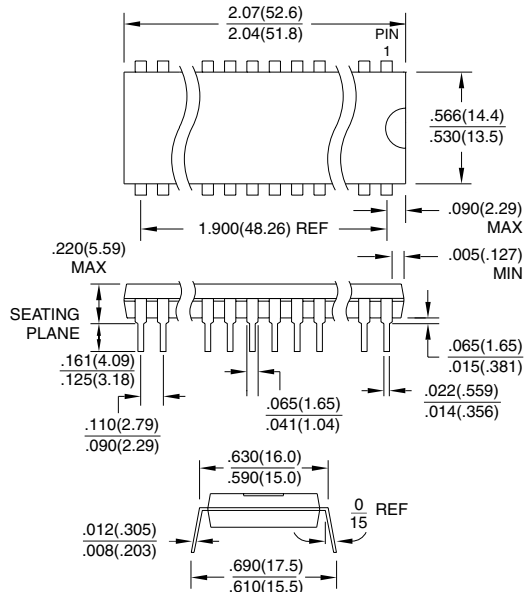

42P6, 42-lead, 0.600" Wide, Plastic Dual Inline Package (PDIP)

Dimensions in Inches and (Millimeters)

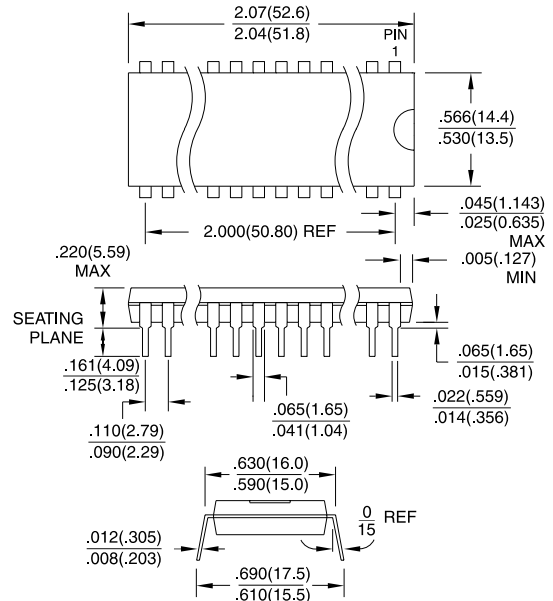

44Q, 44-lead, Plastic Quad Flat Package (PQFP)

Dimensions in Millimeters and (Inches)*
JEDEC STANDARD MS-022 AB

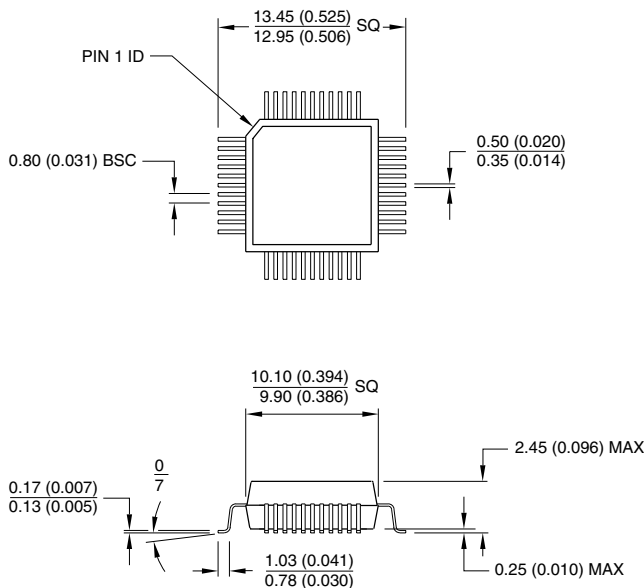

* Controlling dimension: millimeters

100Q, 100-lead, Thin (1.0 mm) Plastic Quad Flat Package (TQFP)

Dimensions in Millimeters and (Inches)*
JEDEC STANDARD MS-026 AED

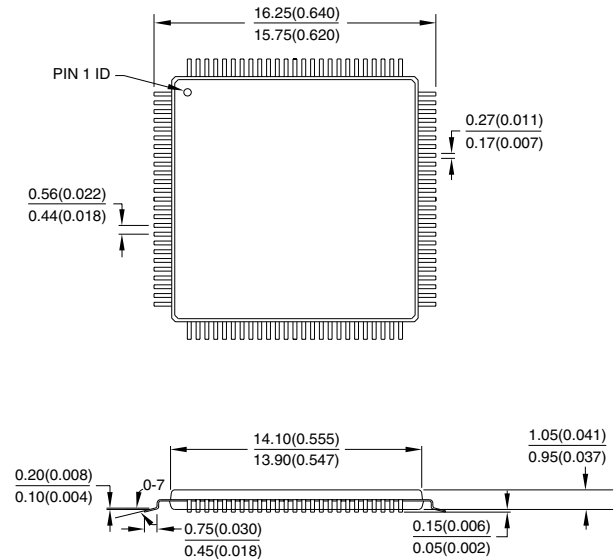

*Controlling dimension: millimeters

Packaging Information

132Q, 132-lead, Bumpered Plastic Quad Flat Package (BQFP)
Dimensions in Millimeters and (Inches)*

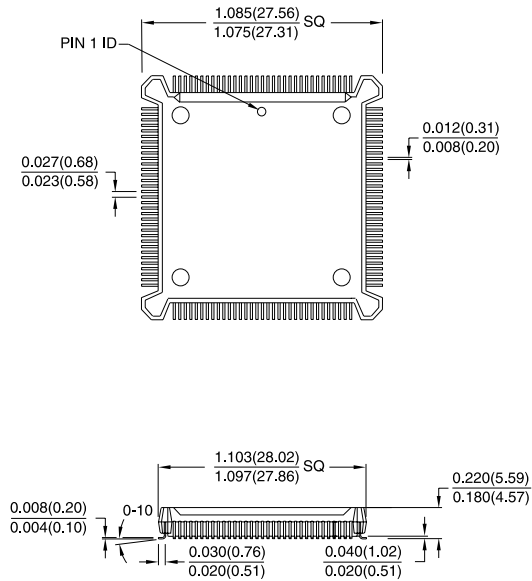

* Controlling dimension: millimeters

136Q, 136-lead, Plastic Quad Flat Package (PQFP)
Dimensions in Millimeters and (Inches)*

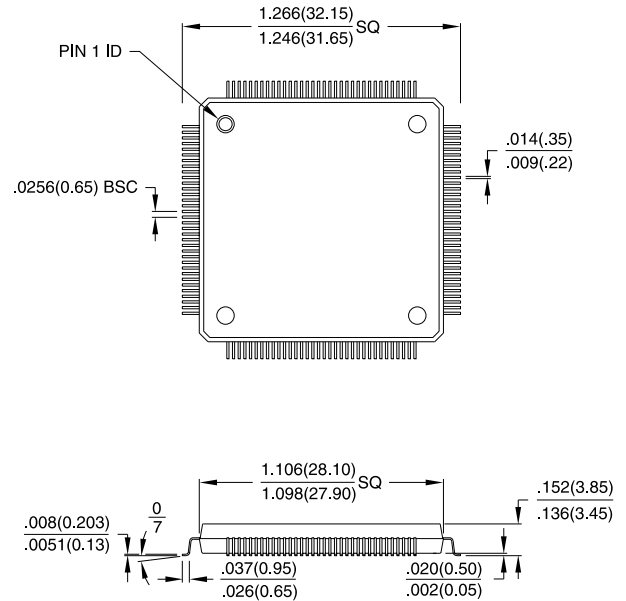

* Controlling dimension: millimeters

144Q, 144-lead, Plastic Gull Wing Quad Flat Package (PQFP)
Dimensions in Millimeters and (Inches)*

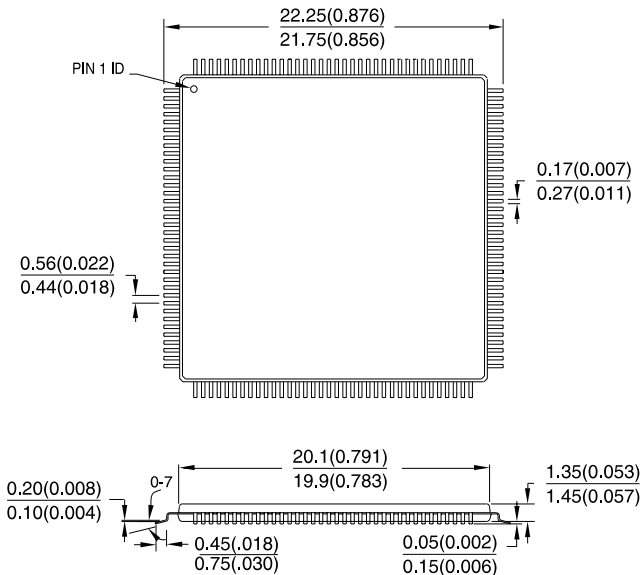

* Controlling dimension: millimeters

160Q, 160-lead, Plastic Gull Wing Quad Flat Package (PQFP)
Dimensions in Millimeters and (Inches)*

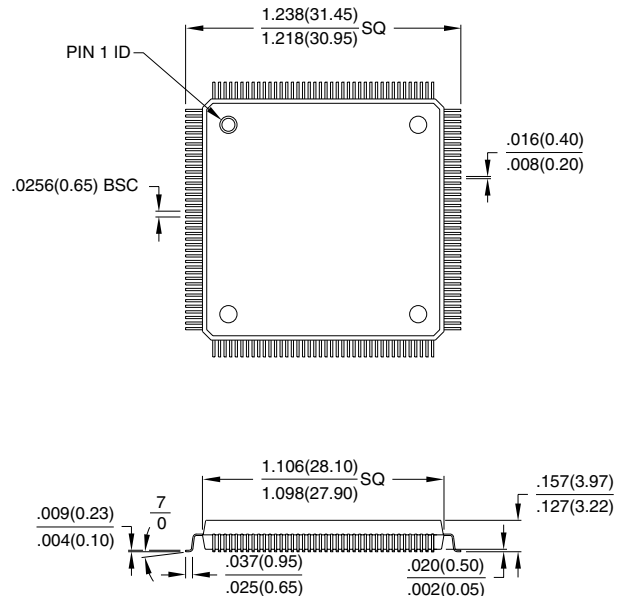

* Controlling dimension: millimeters

Packaging Information

208Q, 208-lead, Plastic Gull Wing Quad Flat Package (PQFP)

Dimensions in Millimeters and (Inches)*

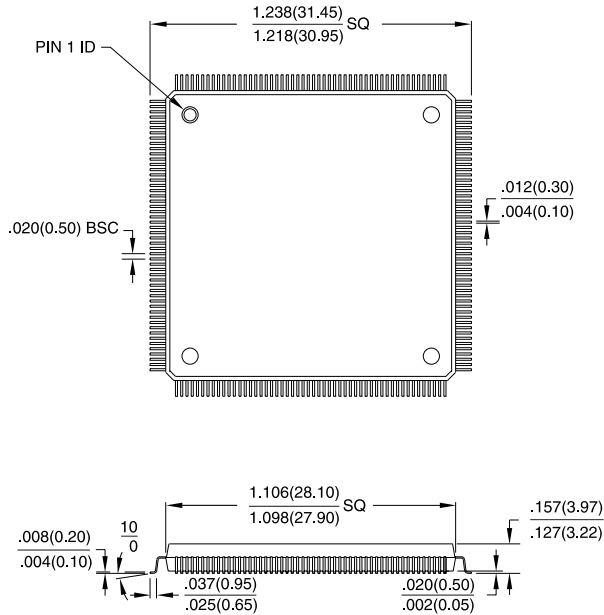

* Controlling dimension: millimeters

240Q, 240-lead, Plastic Gull Wing Quad Flat Package (PQFP)

Dimensions in Millimeters and (Inches)*

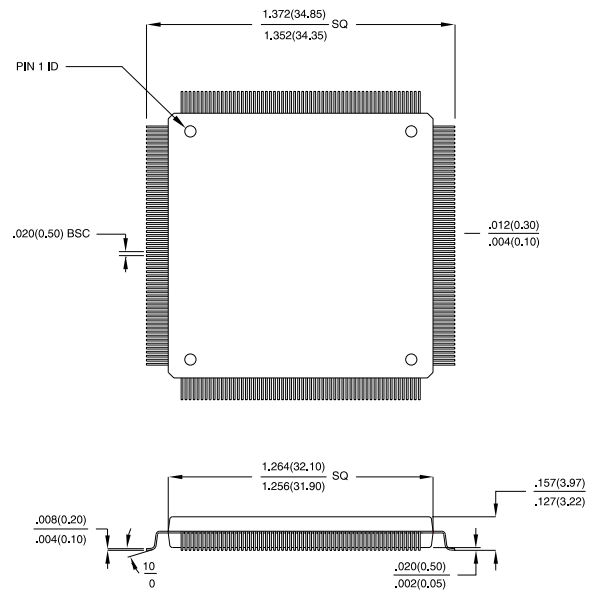

* Controlling dimension: millimeters

100Q1, 100-lead Plastic Quad Flat Package (PQFP)

Body +3.2 mm Footprint

Dimensions in Millimeters and (Inches)*

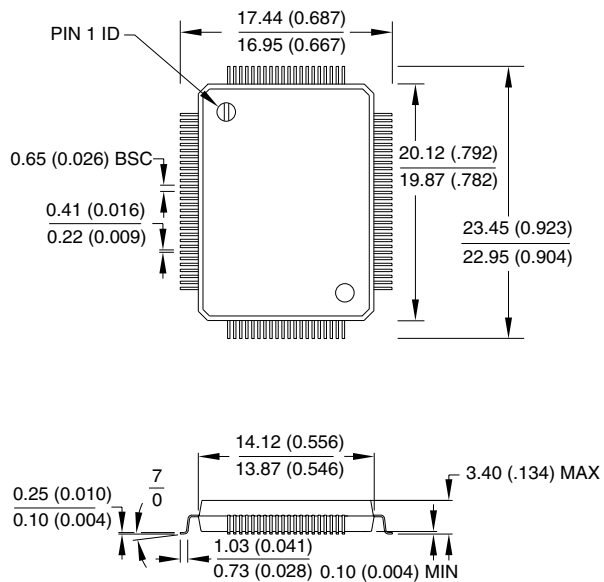

* Controlling dimension: millimeters

100Q2, 100-lead Plastic Quad Flat Package (PQFP)

Dimensions in Millimeters and (Inches)*

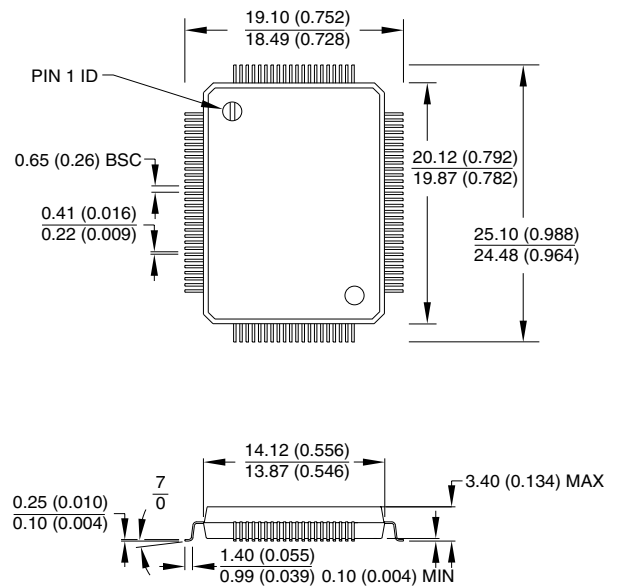

* Controlling dimension: millimeters

Packaging Information

304Q, 304-lead, Plastic Gull Wing Quad Flat Pack (PQFP)
Dimensions in (Millimeters) and Inches

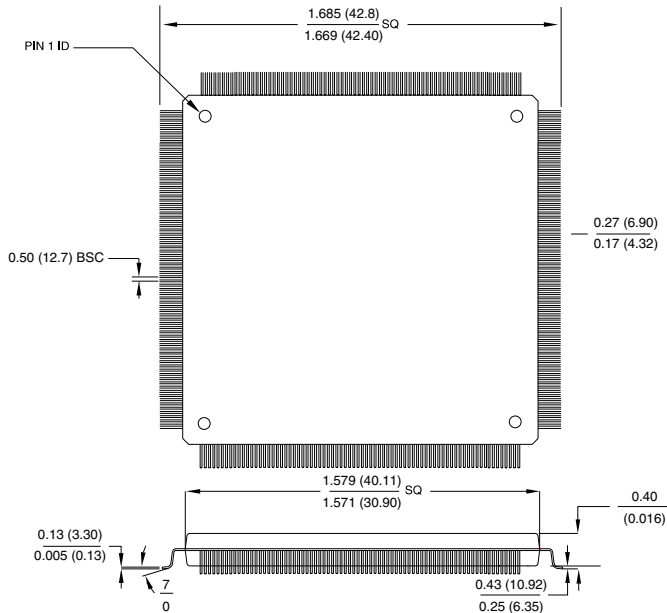

28R, 28-lead, 0.330" Wide, Plastic Gull Wing Small Outline (SOIC)
Dimensions in Inches and (Millimeters)

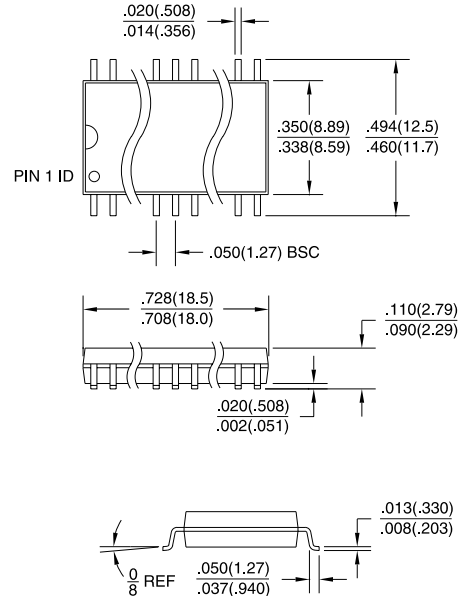

32R, 32-lead, 0.440" Wide, Plastic Gull Wing Small Outline (SOIC)
Dimensions in Inches and (Millimeters)

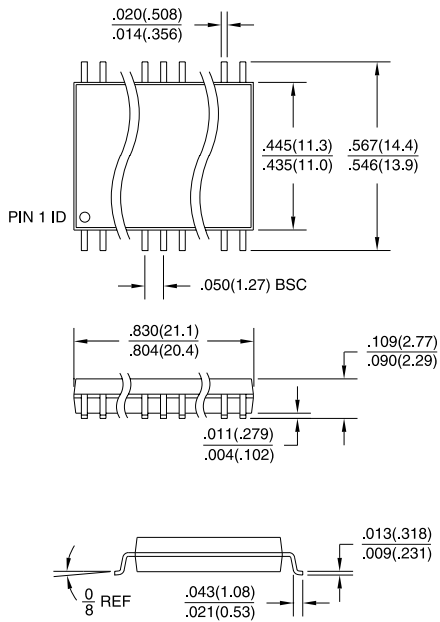

40R, 40-lead, 0.440" Wide, Plastic Gull Wing Small Outline (SOIC)
Dimensions in Inches and (Millimeters)

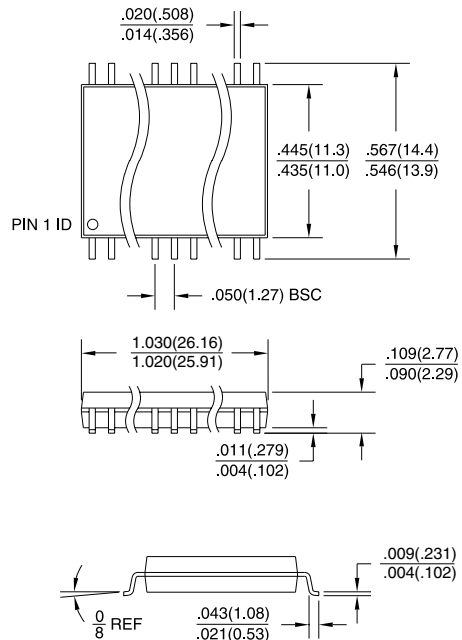

Packaging Information

44R, 44-lead, 0.525" Wide, Plastic Gull Wing Small Outline (SOIC)
Dimensions in Inches and (Millimeters)

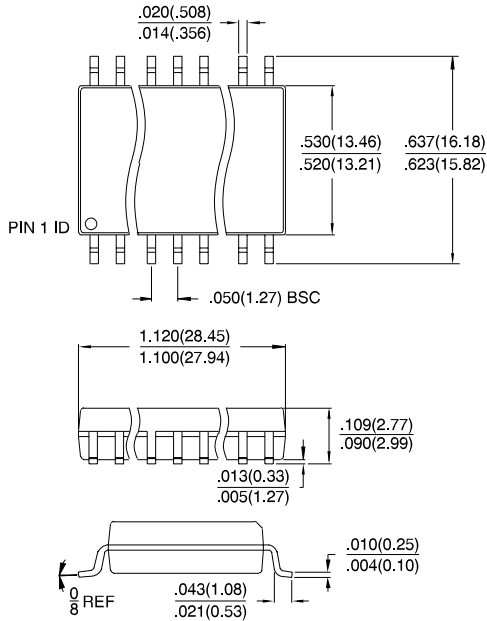

100RQ, 100-lead, Rectangular Plastic Gull Wing Quad Flat Pack (RQFP)
Dimensions in Millimeters and (Inches)*

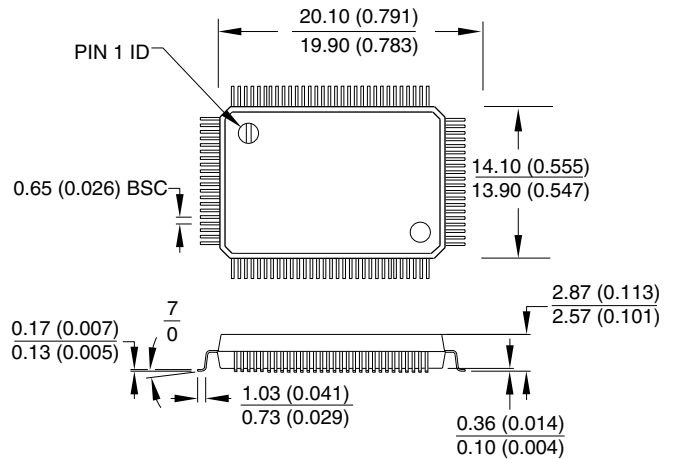

*Controlling dimension: millimeters

14S, 14-lead, 0.150" Wide, Plastic Gull Wing Small Outline (JEDEC SOIC)
Dimensions in Inches and (Millimeters)

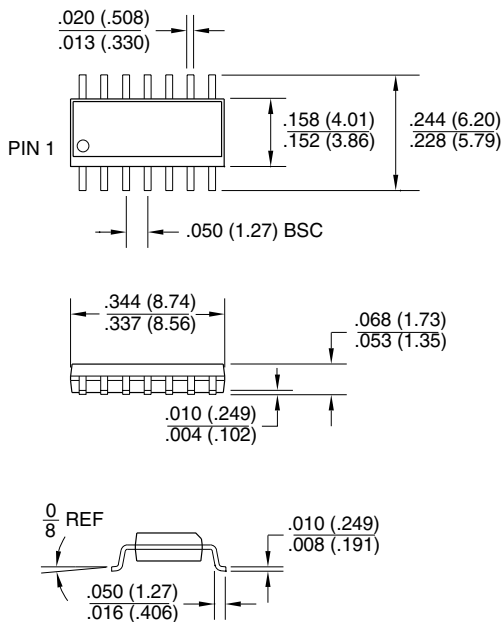

16S, 16-lead, 0.300" Wide, Plastic Gull Wing Small Outline (SOIC)
Dimensions in Inches and (Millimeters)

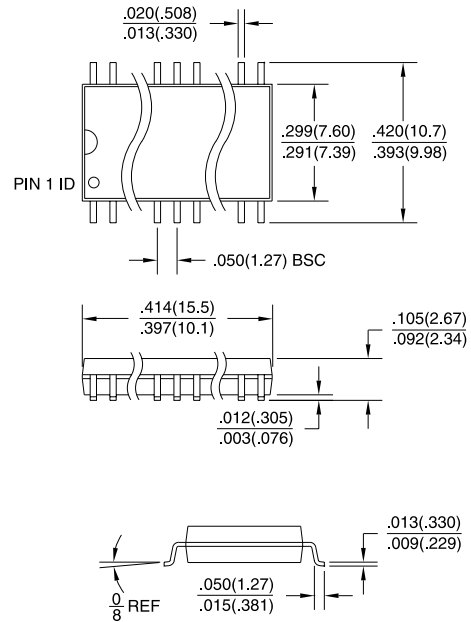

Packaging Information

16S1, 16-lead, 0.150" Wide, Plastic Gull Wing Small Outline (JEDEC SOIC)
Dimensions in Inches and (Millimeters)

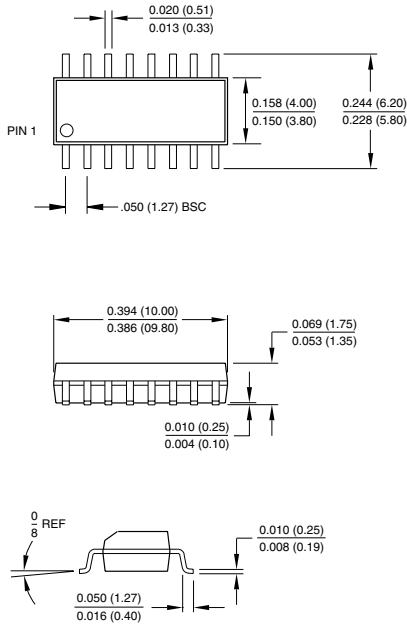

16S2, 16-lead, 0.300" Wide, Plastic Gull Wing Small Outline (JEDEC SOIC)
Dimensions in Inches and (Millimeters)

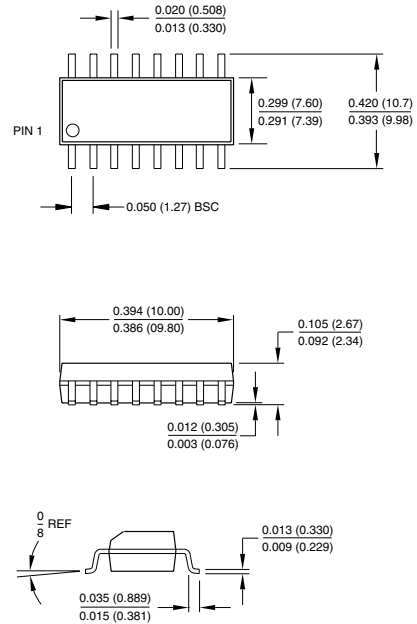

20S, 20-lead, 0.300" Wide, Plastic Gull Wing Small Outline (SOIC)
Dimensions in Inches and (Millimeters)

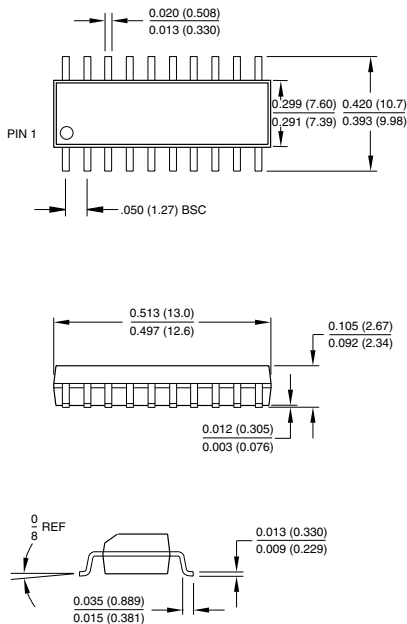

24S, 24-lead, 0.300" Wide, Plastic Gull Wing Small Outline (SOIC)
Dimensions in Inches and (Millimeters)

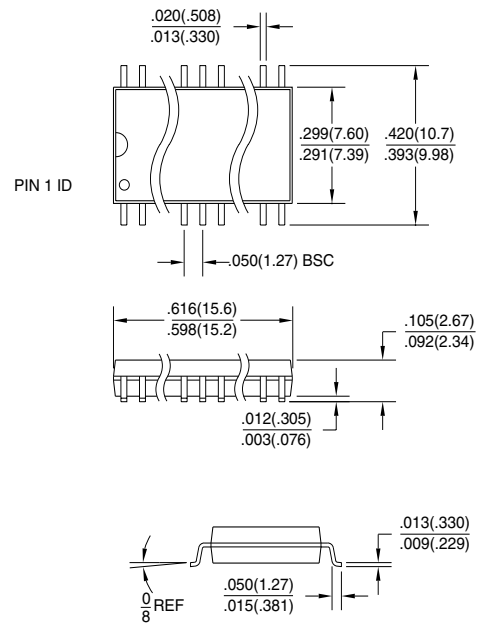

Packaging Information

8S8, 28-lead, 0.300" Wide, Plastic Gull Wing Small Outline (SOIC)
 Dimensions in Inches and (Millimeters)

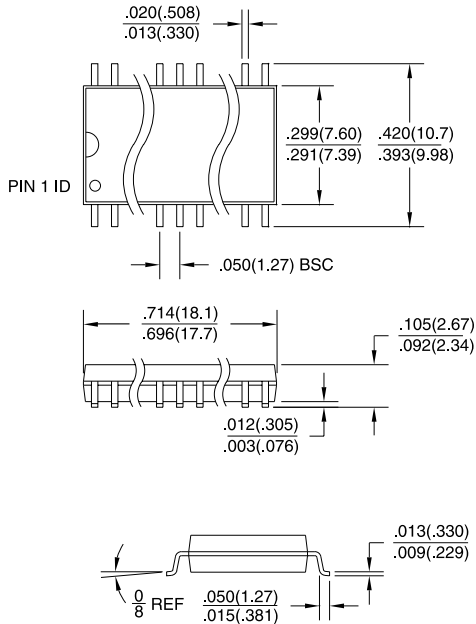

8S1, 8-lead, 0.150" Wide, Plastic Gull Wing Small Outline (JEDEC SOIC)
 Dimensions in Inches and (Millimeters)

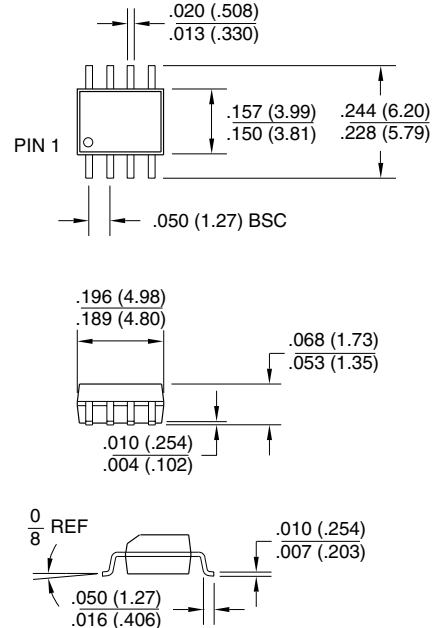

8S2, 8-lead, 0.210" Wide, Plastic Gull Wing Small Outline (EIAJ SOIC)
 Dimensions in Inches and (Millimeters)

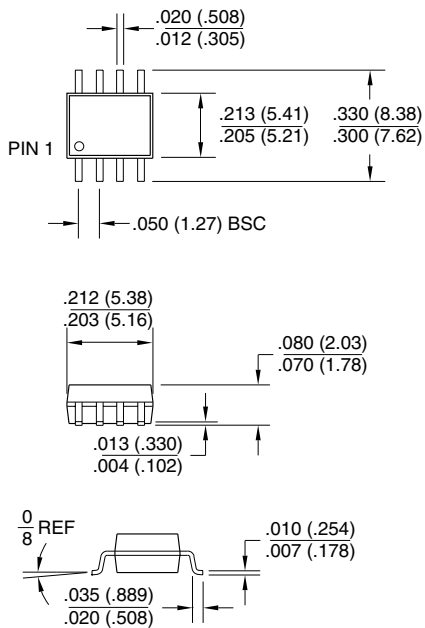

8T, 8-lead, Plastic Thin Shrink Small Outline Package (TSSOP)
 Dimensions in Millimeters and (Inches)*

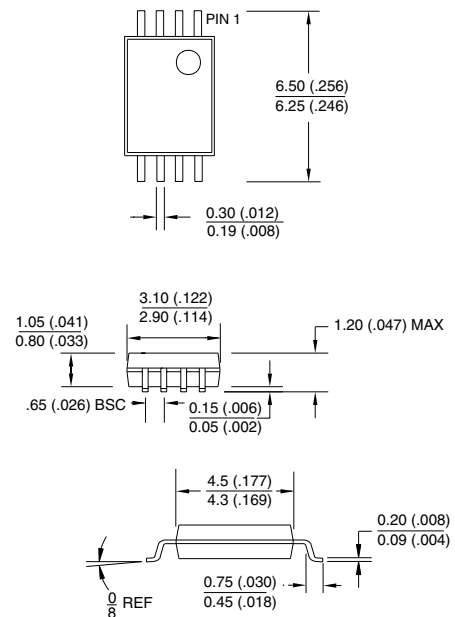

*Controlling dimension: millimeters

Packaging Information

14T, 14-lead, 0.170" Wide, Thin Shrink Small Outline Package (TSSOP)
Dimensions in Millimeters and (Inches)*

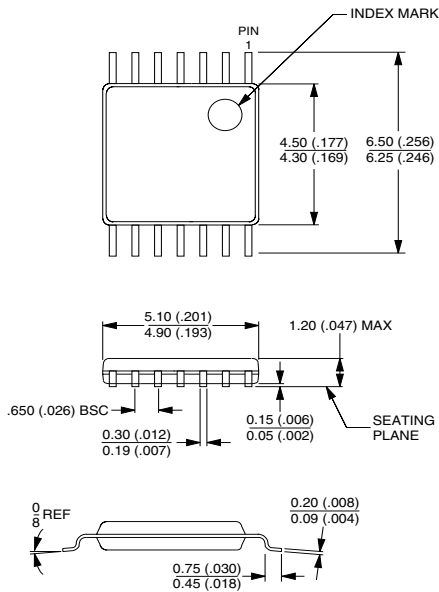

*Controlling dimension: millimeters

20T, 20-lead, 0.170" Wide, Thin Shrink Small Outline Package (TSSOP)
Dimensions in Millimeters and (Inches)*

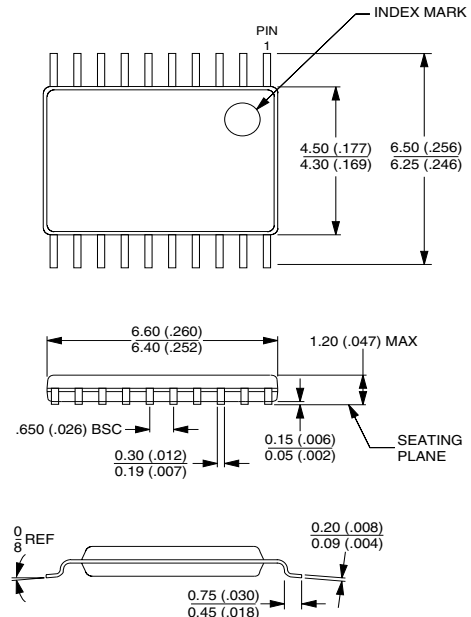

*Controlling dimension: millimeters

28T, 28-lead, Plastic Thin Small Outline Package (TSOP)
Dimensions in Millimeters and (Inches)*

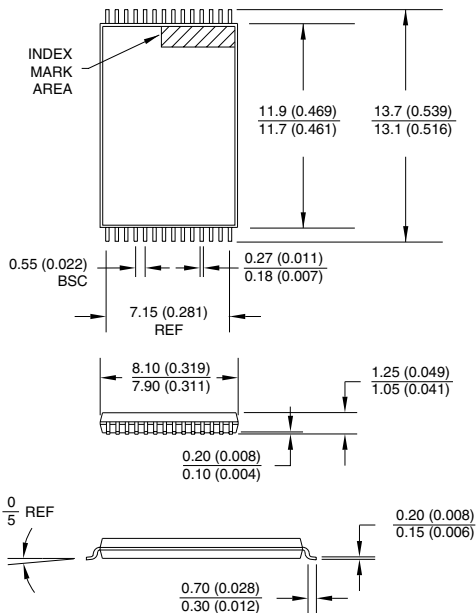

*Controlling dimension: millimeters

32T, 32-lead, Plastic Thin Small Outline Package (TSOP)
JEDEC OUTLINE MO-142 BD
Dimensions in Millimeters and (Inches)*

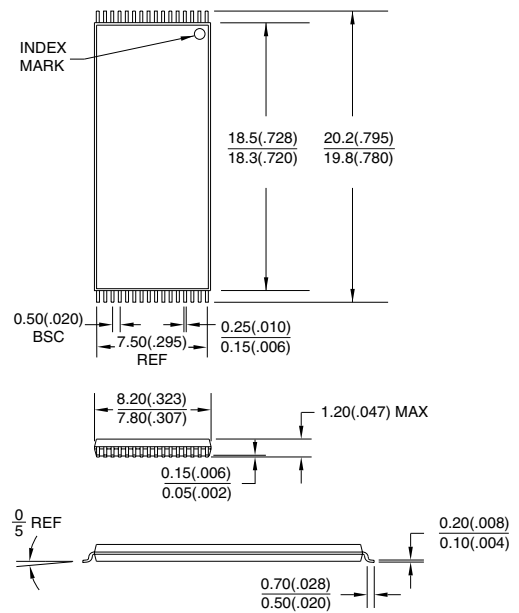

*Controlling dimension: millimeters

Packaging Information

40T, 40-lead, Plastic Thin Small Outline Package (TSOP)

Dimensions in Millimeters and (Inches)*

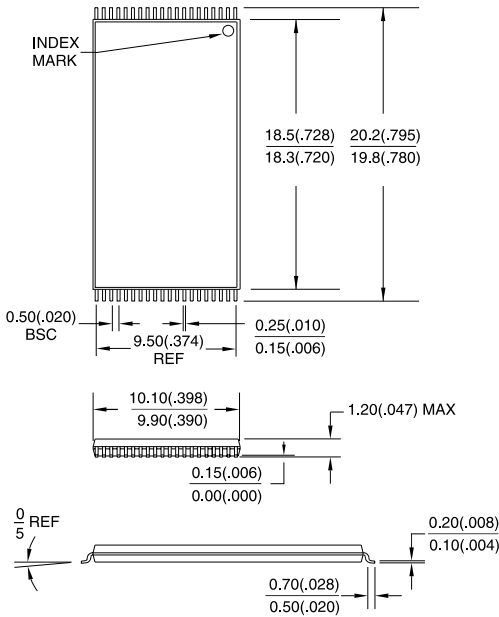

*Controlling dimension: millimeters

48T, 48-lead, Plastic Thin Small Outline Package (TSOP)

Dimensions in Millimeters and (Inches)*

JEDEC OUTLINE MO-142 DD

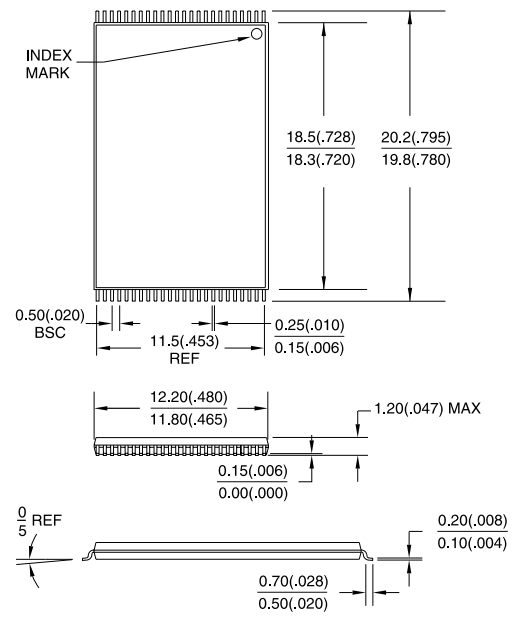

*Controlling dimension: millimeters

86T, 86-lead, Plastic Thin Small Outline Package (TSOP Type II)

Dimensions in Millimeters

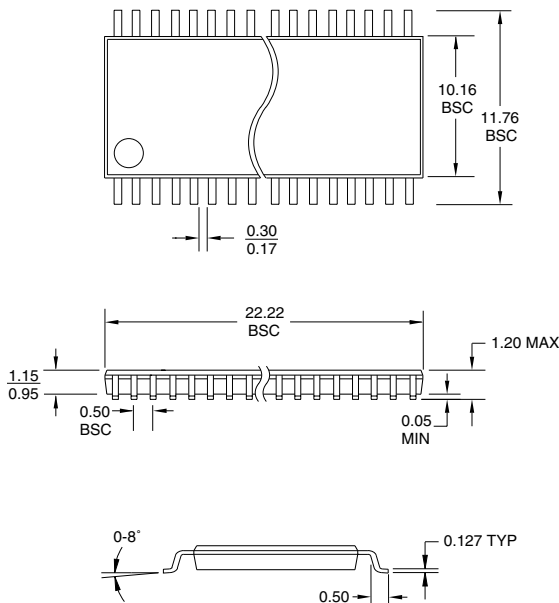

28U, 28-pin, Ceramic Pin Grid Array (PGA)

Dimensions in Inches and (Millimeters)

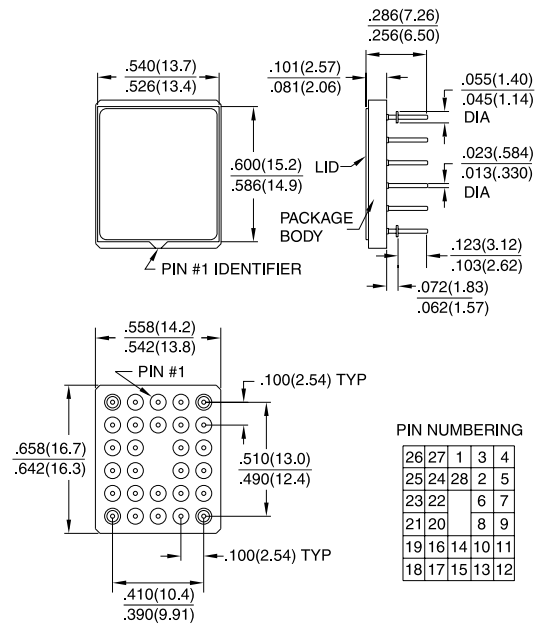

Packaging Information

30U, 30-pin, Ceramic Pin Grid Array (PGA)
Dimensions in Inches and (Millimeters)

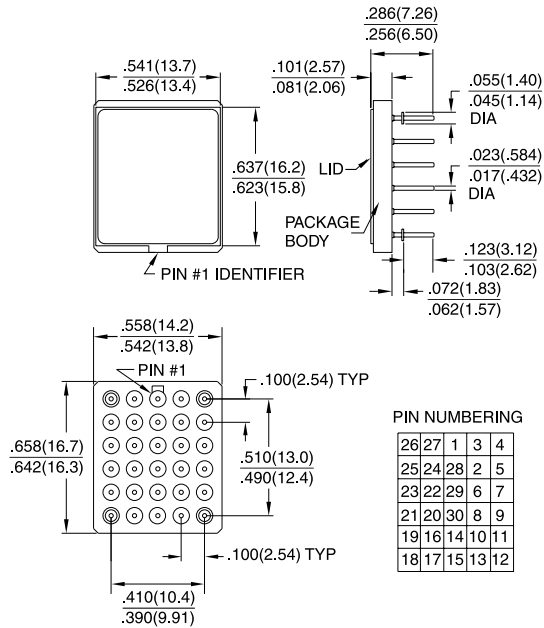

48U, 48-ball, Micro Ball Grid Array Package (μBGA)
Dimensions in Millimeters

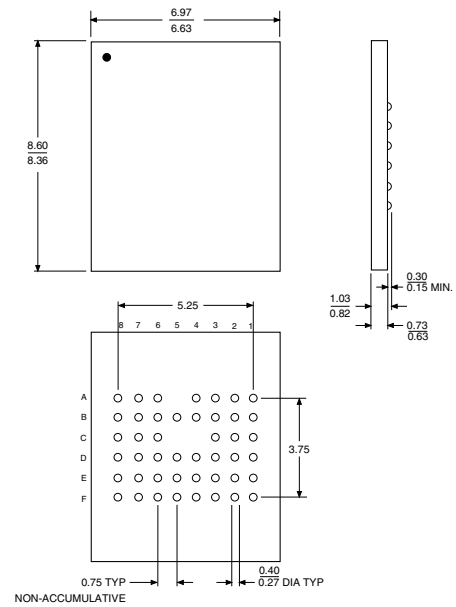

180U, 180-pin, Ceramic Pin Grid Array (PGA)
Dimensions in Inches and (Millimeters)

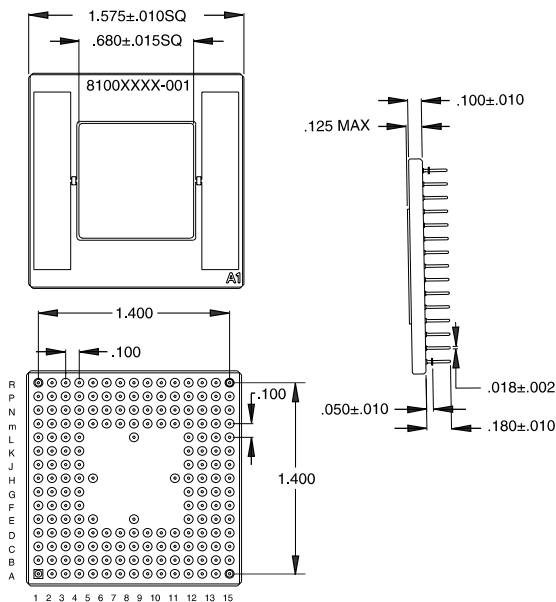

68UW, 68-pin, Ceramic Pin Grid Array (PGA)
Dimensions in Inches and (Millimeters)

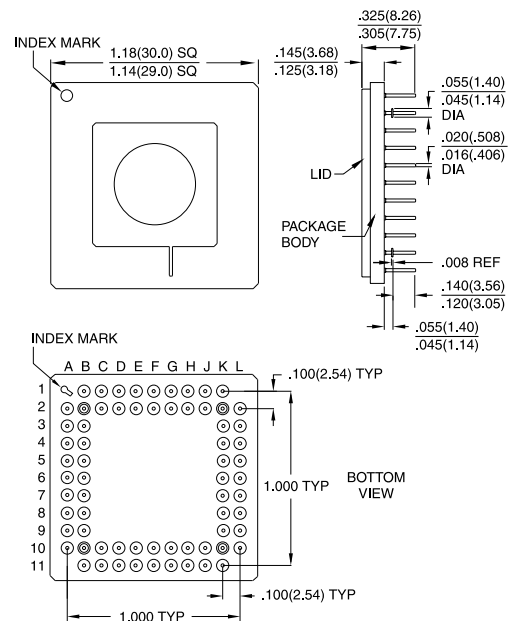

Packaging Information

32V, 32-lead, Plastic Thin Small Outline Package (VSOP)

Dimensions in Millimeters and (Inches)*

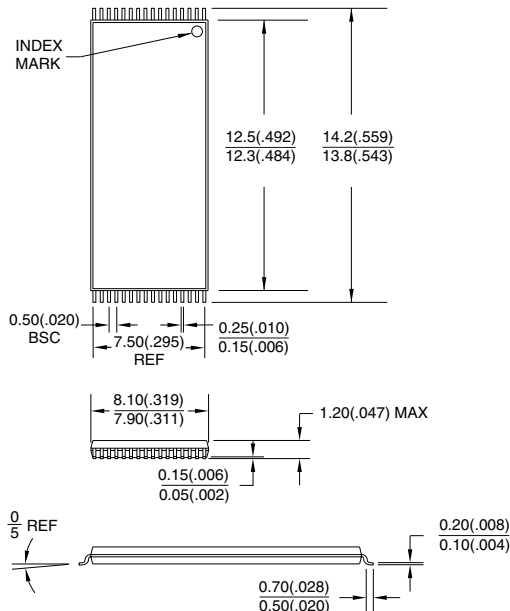

*Controlling dimension: millimeters

40V, 40-lead, Plastic Thin Small Outline Package (VSOP)

Dimensions in Millimeters and (Inches)*

JEDEC OUTLINE MO-142 CA

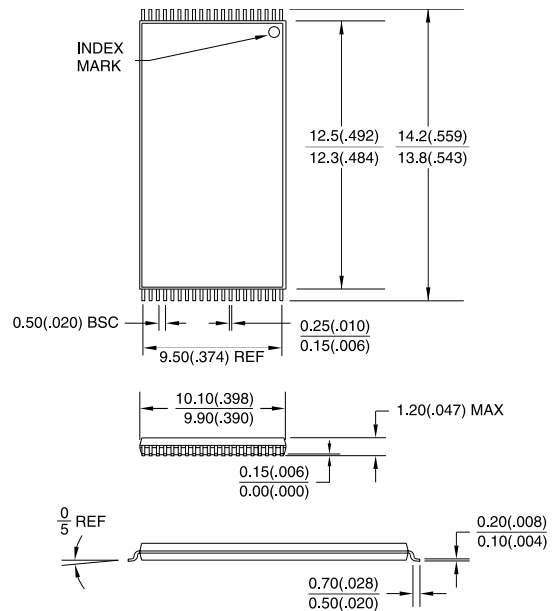

*Controlling dimension: millimeters

20X, 20-lead, 4.4 mm Wide, Plastic Thin Shrink Small Outline (TSSOP)

Dimensions in Millimeters and (Inches)*

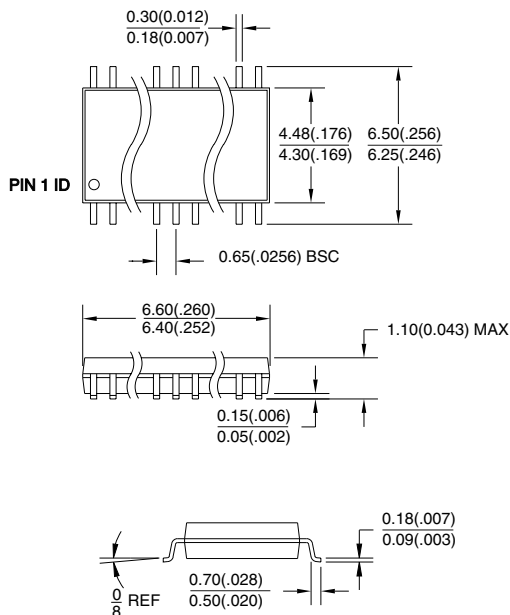

*Controlling dimension: millimeters

24X, 24-lead, 4.4 mm Wide, Plastic Thin Shrink Small Outline (TSSOP)

Dimensions in Millimeters and (Inches)*

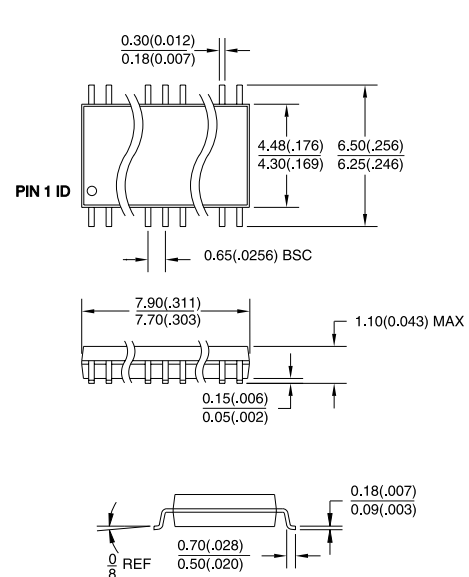

*Controlling dimension: millimeters

Packaging Information

20Y, 20-lead, 5.3 mm Wide, Plastic Shrink Small Outline (SSOP)
 Dimensions in Millimeters and (Inches)*

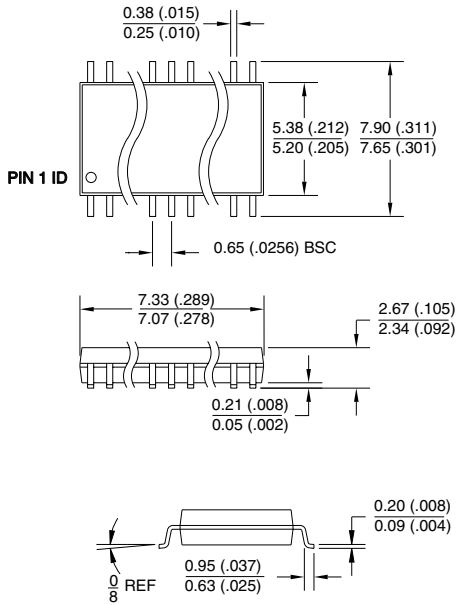

*Controlling dimension: millimeters



Atmel Headquarters

Corporate Headquarters
2325 Orchard Parkway
San Jose, CA 95131
TEL (408) 441-0311
FAX (408) 487-2600

Europe

Atmel U.K., Ltd.
Coliseum Business Centre
Riverside Way
Camberley, Surrey GU15 3YL
England
TEL (44) 1276-686-677
FAX (44) 1276-686-697

Asia

Atmel Asia, Ltd.
Room 1219
Chinachem Golden Plaza
77 Mody Road Tsimhatsui
East Kowloon
Hong Kong
TEL (852) 2721-9778
FAX (852) 2722-1369

Japan

Atmel Japan K.K.
9F, Tonetsu Shinkawa Bldg.
1-24-8 Shinkawa
Chuo-ku, Tokyo 104-0033
Japan
TEL (81) 3-3523-3551
FAX (81) 3-3523-7581

Atmel Operations

Atmel Colorado Springs
1150 E. Cheyenne Mtn. Blvd.
Colorado Springs, CO 80906
TEL (719) 576-3300
FAX (719) 540-1759

Atmel Rousset

Zone Industrielle
13106 Rousset Cedex
France
TEL (33) 4-4253-6000
FAX (33) 4-4253-6001

Fax-on-Demand

North America:
1-(800) 292-8635
International:
1-(408) 441-0732

e-mail

literature@atmel.com

Web Site

<http://www.atmel.com>

BBS

1-(408) 436-4309

© Atmel Corporation 1999.

Atmel Corporation makes no warranty for the use of its products, other than those expressly contained in the Company's standard warranty which is detailed in Atmel's Terms and Conditions located on the Company's web site. The Company assumes no responsibility for any errors which may appear in this document, reserves the right to change devices or specifications detailed herein at any time without notice, and does not make any commitment to update the information contained herein. No licenses to patents or other intellectual property of Atmel are granted by the Company in connection with the sale of Atmel products, expressly or by implication. Atmel's products are not authorized for use as critical components in life support devices or systems.

Marks bearing ® and/or ™ are registered trademarks and trademarks of Atmel Corporation.

Terms and product names in this document may be trademarks of others.



Printed on recycled paper.

0555F-03/00/xM