

## Features

- Industry-standard Architecture
- 12 ns Maximum Pin-to-pin Delay
- Zero Power – 25  $\mu$ A Maximum Standby Power
- CMOS and TTL Compatible Inputs and Outputs
- Advanced Electrically-erasable Technology
  - Reprogrammable
  - 100% Tested
- Latch Feature Holds Inputs to Previous Logic State
- High-reliability CMOS Process
  - 20 Year Data Retention
  - 100 Erase/Write Cycles
  - 2,000V ESD Protection
  - 200 mA Latchup Immunity
- Commercial and Industrial Temperature Ranges
- Dual-in-line and Surface Mount Standard Pinouts
- PCI Compliant

## Block Diagram

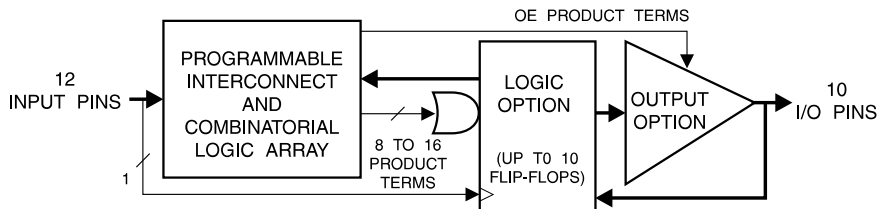

## Description

The ATF22V10CZ is a high-performance CMOS (electrically-erasable) Programmable Logic Device (PLD) which utilizes Atmel's proven electrically-erasable *(continued)*

## Pin Configurations

All Pinouts Top View

Pin Name	Function
CLK	Clock
IN	Logic Inputs
I/O	Bidirectional Buffers
VCC	+5V Supply

PLCC

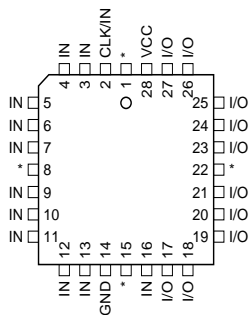

Note: For PLCC, P1, P8, P15 and P22 can be left unconnected. Connect VCC to pin 1 and GND to 8, 15, and 22.

TSSOP

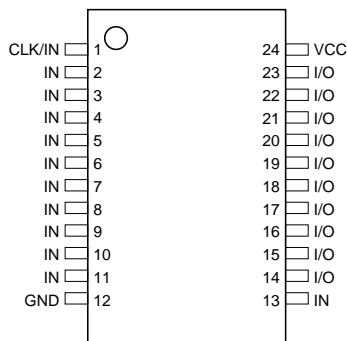

DIP/SOIC

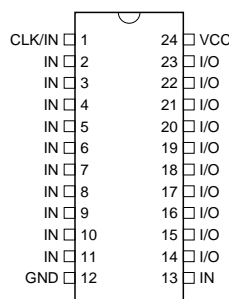

High-performance  
EE PLD

ATF22V10CZ





Flash memory technology. Speeds down to 12 ns with zero standby power dissipation are offered. All speed ranges are specified over the full 5V ±10% range for industrial temperature ranges; 5V ±5% for commercial range 5-volt devices. The ATF22LV10CZ provides a low voltage and edge-sensing “zero” power CMOS PLD solution with “zero” standby power (5 mA typical). The ATF22LV10CZ powers down automatically to the zero The ATF22V10CZ provides a “zero” power CMOS PLD solution with 5V operating voltages. The ATF22V10CZ powers down automatically to the zero power-mode through Atmel’s patented Input Transition Detection (ITD) circuitry when the device is idle. The ATF22V10CZ has an edge-sensing power-down feature,

offering “zero” (25 mA worst case) standby power. This feature allows the user to manage total system power to meet specific application requirements and enhance reliability. Pin “keeper” circuits on input and output pins eliminate static power consumed by pull-up resistors.

The ATF22V10CZ incorporates a superset of the generic architectures, which allows direct replacement of the 22V10 family and most 24-pin combinatorial PLDs. Ten outputs are each allocated 8 to 16 product terms. Three different modes of operation, configured automatically with software, allow highly complex logic functions to be realized.

### Absolute Maximum Ratings\*

Temperature Under Bias.....	-40°C to +85°C
Storage Temperature.....	-65°C to +150°C
Voltage on Any Pin with Respect to Ground .....	-2.0V to +7.0V <sup>(1)</sup>
Voltage on Input Pins with Respect to Ground During Programming.....	-2.0V to +14.0V <sup>(1)</sup>
Programming Voltage with Respect to Ground .....	-2.0V to +14.0V <sup>(1)</sup>

\*NOTICE: Stresses beyond those listed under “Absolute Maximum Ratings” may cause permanent damage to the device. This is a stress rating only and functional operation of the device at these or any other conditions beyond those indicated in the operational sections of this specification is not implied. Exposure to absolute maximum rating conditions for extended periods may affect device reliability.

Note: 1. Minimum voltage is -0.6V DC, which may undershoot to -2.0V for pulses of less than 20 ns. Maximum output pin voltage is  $V_{CC} + 0.75V$  DC, which may overshoot to 7.0V for pulses of less than 20 ns.

### DC and AC Operating Conditions

	Commercial	Industrial
Operating Temperature (Ambient)	0°C - 70°C	-40°C - 85°C
V <sub>CC</sub> Power Supply	5V ± 5%	5V ± 10%

### Compiler Mode Selection

	PAL Mode (5828 Fuses)	GAL Mode (5892 Fuses)
Synario	ATF22V10C (DIP) ATF22V10C (PLCC)	ATF22V10C DIP (UES) ATF22V10C PLCC (UES)
WINCUPL	P22V10 P22V10LCC	G22V10 G22V10LCC

## Functional Logic Diagram Description

The Functional Logic Diagram describes the ATF22V10CZ architecture.

The ATF22V10CZ has 12 inputs and 10 I/O macrocells. Each macrocell can be configured into one of four output configurations: active high/low, registered/combinatorial output. The universal architecture of the ATF22V10CZ can be programmed to emulate most 24-pin PAL devices.

Unused product terms are automatically disabled by the compiler to decrease power consumption. A Security Fuse, when programmed, protects the contents of the ATF22V10CZ. Eight bytes (64 fuses) of User Signature are accessible to the user for purposes such as storing project name, part number, revision or date. The User Signature is accessible regardless of the state of the Security Fuse.

## DC Characteristics

Symbol	Parameter	Condition	Min	Typ	Max	Units
$I_{IL}$	Input or I/O Low Leakage Current	$0 \leq V_{IN} \leq V_{IL} (Max)$			-10	$\mu A$
$I_{IH}$	Input or I/O High Leakage Current	$3.5 \leq V_{IN} \leq V_{CC}$			10	$\mu A$
$I_{CC}$	Clocked Power Supply Current	$V_{CC} = Max$ Outputs Open, $f = 15 MHz$	Com	90	150	mA
			Ind	90	180	mA
$I_{SB}$	Power Supply Current, Standby	$V_{CC} = Max$ $V_{IN} = MAX$ Outputs Open	Com	5	25	$\mu A$
			Ind	5	50	$\mu A$
$I_{OS}^{(1)}$	Output Short Circuit Current	$V_{OUT} = 0.5V$			-150	mA
$V_{IL}$	Input Low Voltage		-0.5		0.8	V
$V_{IH}$	Input High Voltage		2.0		$V_{CC} + 0.75$	V
$V_{OL}$	Output Low Voltage	$V_{IN} = V_{IH} \text{ or } V_{IL}$ $V_{CC} = Min,$ $I_{OL} = 16 mA$	Com.		0.5	V
			Ind.			
$V_{OH}$	Output High Voltage	$V_{IN} = V_{IH} \text{ or } V_{IL}$ $V_{CCIO} = Min,$ $I_{OH} = -4.0 mA$		2.4		V

Notes: 1. Not more than one output at a time should be shorted. Duration of short circuit test should not exceed 30 sec.

## AC Waveforms

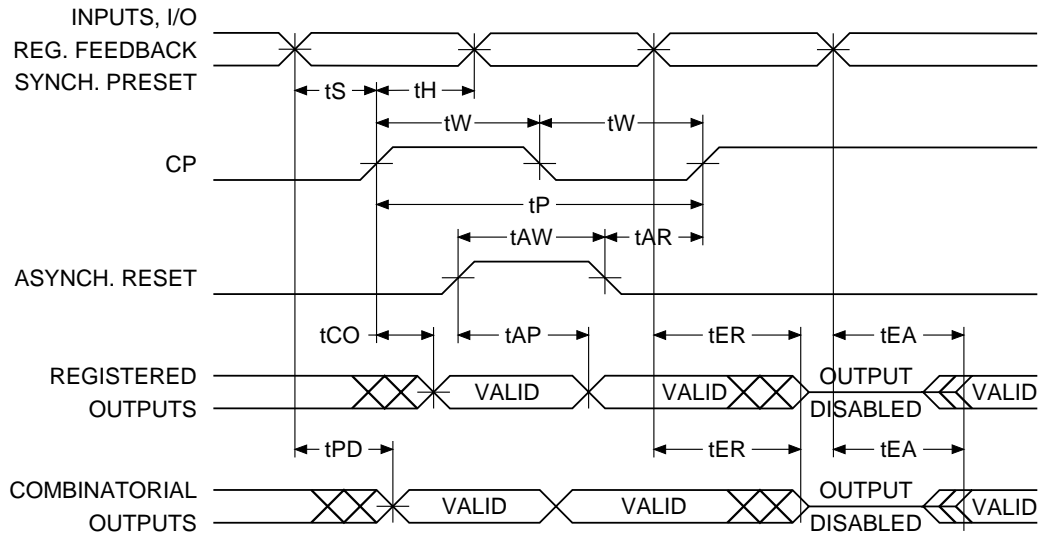

## AC Characteristics<sup>(1)</sup>

Symbol	Parameter	-12		-15		Units
		Min	Max	Min	Max	
$t_{PD}$	Input or Feedback to Non-Registered Output	3	12	3	15	ns
$t_{CF}$	Clock to Feedback		6		4.5	ns
$t_{CO}$	Clock to Output	2	8	2	8	ns
$t_S$	Input or Feedback Setup Time	10		10		ns
$t_H$	Input Hold Time	0		0		ns
$t_P$	Clock Period	12		12		ns
$t_W$	Clock Width	6		6		ns
$F_{MAX}$	External Feedback $1/(t_S + t_{CO})$		55.5		55.5	MHz
	Internal Feedback $1/(t_S + t_{CF})$		62		69	MHz
	No Feedback $1/(t_P)$		83.3		83.3	MHz
$t_{EA}$	Input to Output Enable - Product Term	3	12	3	15	ns
$t_{ER}$	Input to Output Disable - Product Term	2	15	3	15	ns
$t_{PZX}$	OE Pin to Output Enable	2	12	2	15	ns
$t_{PXZ}$	OE Pin to Output Disable	2	15	2	15	ns
$t_{AP}$	Input or I/O to Asynchronous Reset of Register	3	10	3	15	ns
$t_{SP}$	Setup Time, Synchronous Preset	10		10		ns
$t_{AW}$	Asynchronous Reset Width	7		8		ns
$t_{AR}$	Asynchronous Reset Recovery Time	5		6		ns
$t_{SPR}$	Synchronous Preset to Clock Recovery Time	10		10		ns

Note: 1. See ordering information for valid part numbers.

## Input Test Waveforms and Measurement Levels

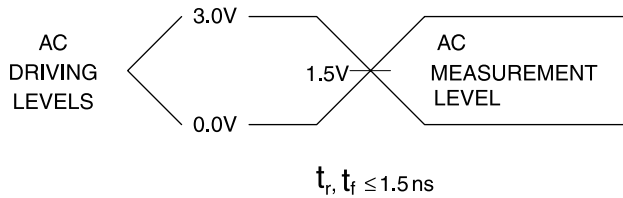

## Output Test Loads

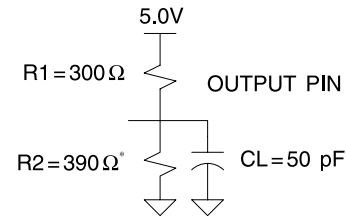

Note: Similar competitor devices are specified with slightly different loads. These load differences may affect output signals' delay and slew rate. Atmel devices are tested with sufficient margins to meet compatible device specification conditions.

## Pin Capacitance

f = 1 MHz, T = 25°C<sup>(1)</sup>

	Typ	Max	Units	Conditions
C <sub>IN</sub>	8	10	pF	V <sub>IN</sub> = 0V; f = 1.0 MHz
C <sub>I/O</sub>	8	10	pF	V <sub>OUT</sub> = 0V; f = 1.0 MHz

Note: 1. Typical values for nominal supply voltage. This parameter is only sampled and is not 100% tested.

## Power-up Reset

The registers in the ATF22V10CZ are designed to reset during power-up. At a point delayed slightly from VCC crossing VRST, all registers will be reset to the low state. The output state will depend on the polarity of the buffer.

This feature is critical for state machine initialization. However, due to the asynchronous nature of reset and the uncertainty of how V<sub>CC</sub> actually rises in the system, the following conditions are required:

1. The V<sub>CC</sub> rise must be monotonic and start below 0.7V.
2. The clock must remain stable during TPR.
3. After TPR occurs, all input and feedback setup times must be met before driving the clock pin high.

## Preload of Register Outputs

The ATF22V10CZ's registers are provided with circuitry to allow loading of each register with either a high or a low. This feature will simplify testing since any state can be forced into the registers to control test sequencing. A JEDEC file with preload is generated when a source file with vectors is compiled. Once downloaded, the JEDEC file preload sequence will be done automatically by most of the approved programmers after the programming.

## Electronic Signature Word

There are 64 bits of programmable memory that are always available to the user, even if the device is secured. These bits can be used for user-specific data.

## Security Fuse Usage

A single fuse is provided to prevent unauthorized copying of the ATF22V10CZ fuse patterns. Once programmed, fuse verify and preload are inhibited. However, the 64-bit User Signature remains accessible. The security fuse should be programmed last, as its effect is immediate.

## Programming/Erasing

Programming/erasing is performed using standard PLD programmers. See CMOS PLD Programming Hardware & Software Support for information on software/programming.

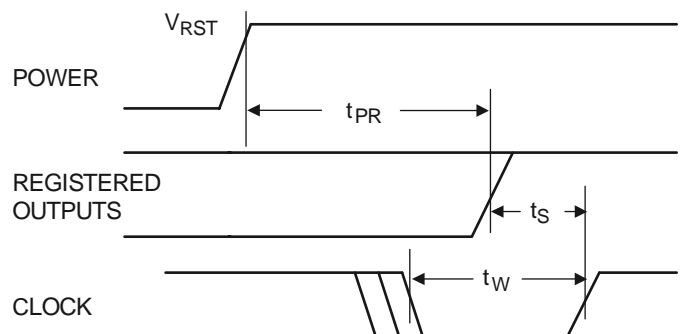

Parameter	Description	Typ	Max	Units
T <sub>PR</sub>	Power-up Reset Time	600	1000	ns
V <sub>RST</sub>	Power-up Reset Voltage	3.8	4.5	V

## Input and I/O Pull-ups

All ATF22V10CZ family members have internal input and I/O pin-keeper circuits. Therefore, whenever inputs or I/Os are not being driven externally, they will maintain their last driven state. This ensures that all logic array inputs and

device outputs are at known states. These are relatively weak active circuits that can be easily overridden by TTL-compatible drivers (see input and I/O diagrams below).

### Input Diagram

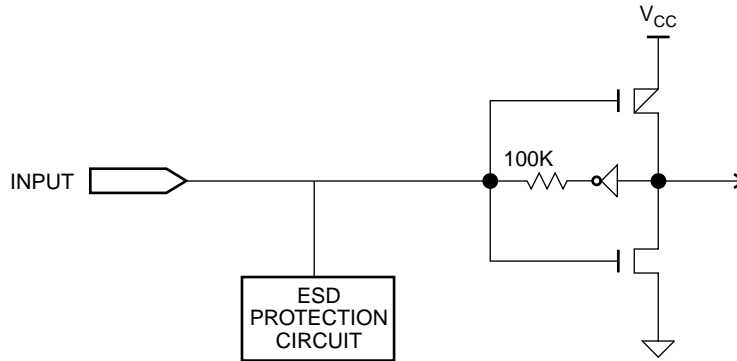

### I/O Diagram

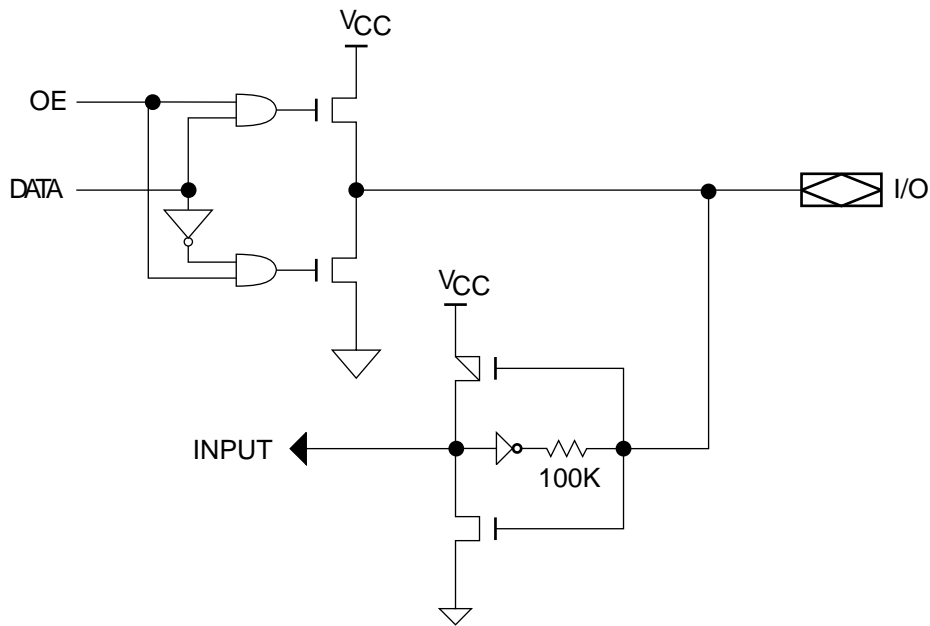

Functional Logic Diagram ATF22V10CZ

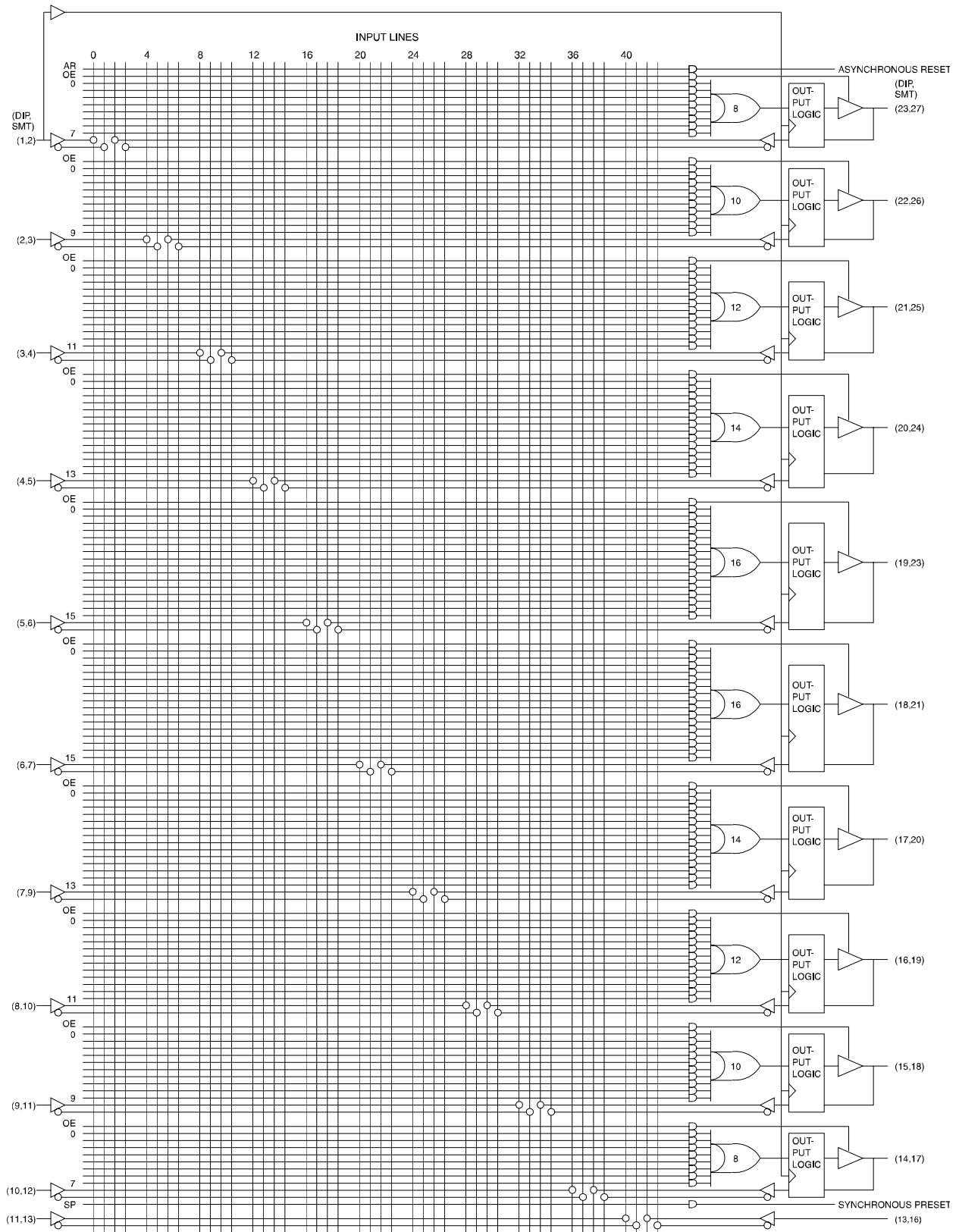

**ATF22V10CZ SUPPLY CURRENT VS. SUPPLY VOLTAGE (TA = 25C)**

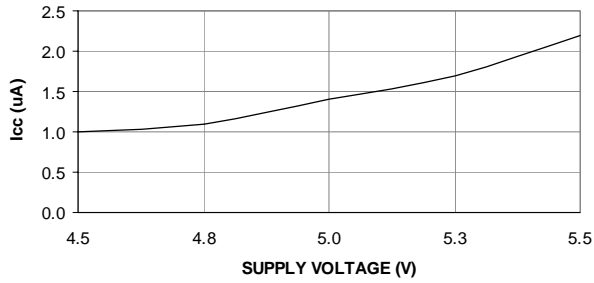

**NORMALIZED ICC VS. TEMP**

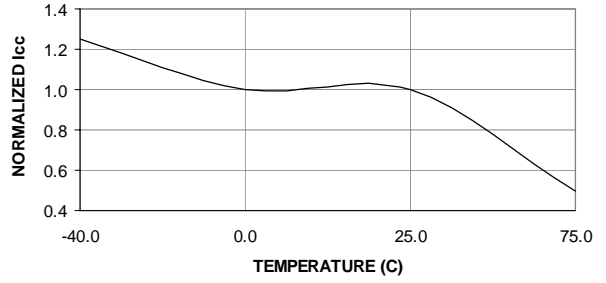

**NORMALIZED ICC VS. TEMP**

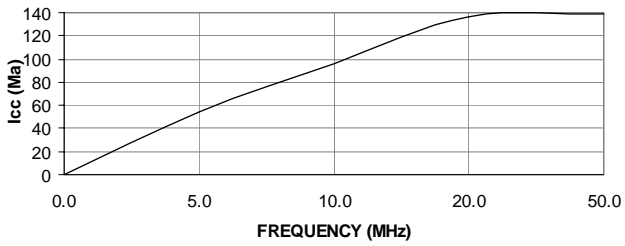

**ATF22V10C/CZ OUTPUT SOURCE CURRENT VS SUPPLY VOLTAGE (V<sub>oh</sub> = 2.4V)**

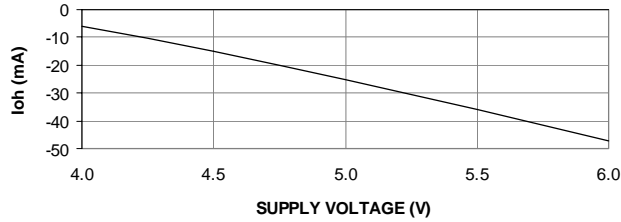

**ATF22V10CZ OUTPUT SOURCE CURRENT VS. OUTPUT VOLTAGE (V<sub>CC</sub> = 5V, TA = 25C)**

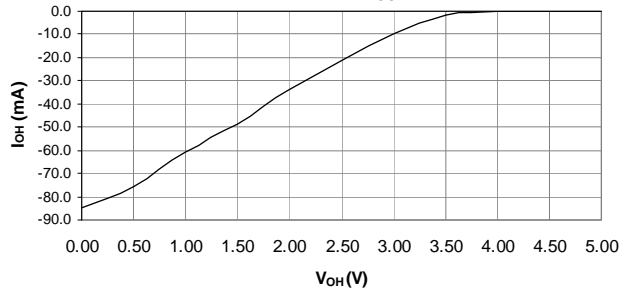

**ATF22V10C/CZ OUTPUT SINK CURRENT VS. SUPPLY VOLTAGE (V<sub>ol</sub> = 0.5V)**

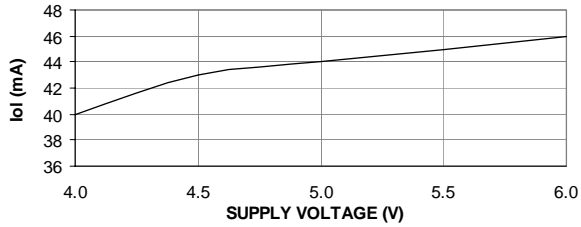

**ATF22V10CZ OUTPUT SINK CURRENT VS. SUPPLY VOLTAGE (V<sub>OL</sub> = 0.5V)**

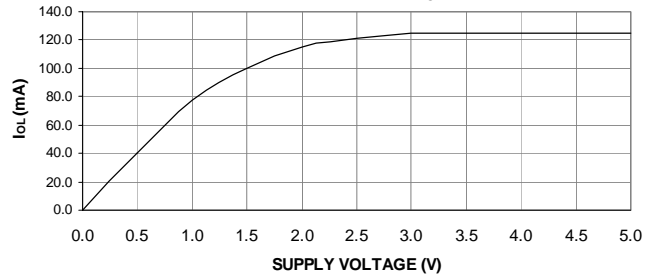



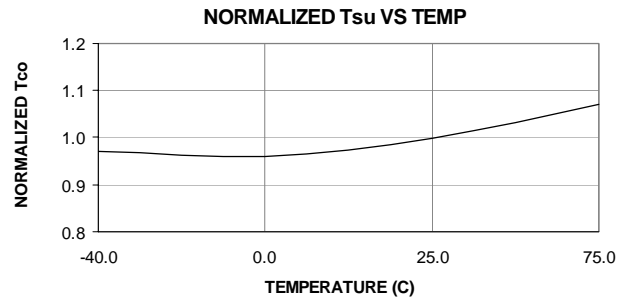
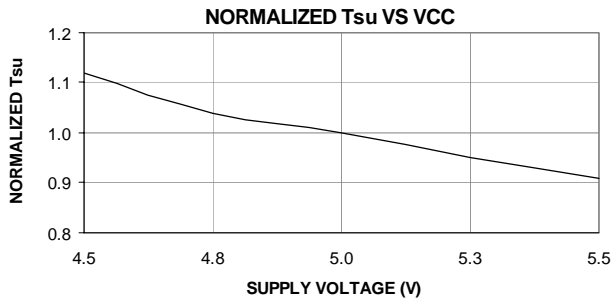
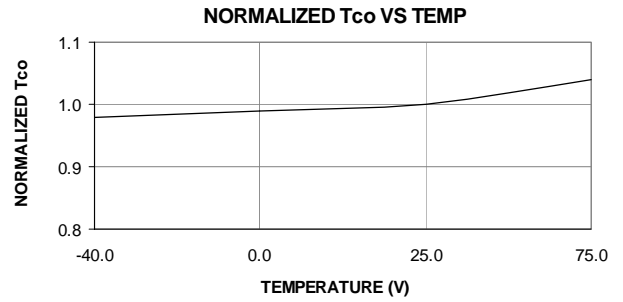
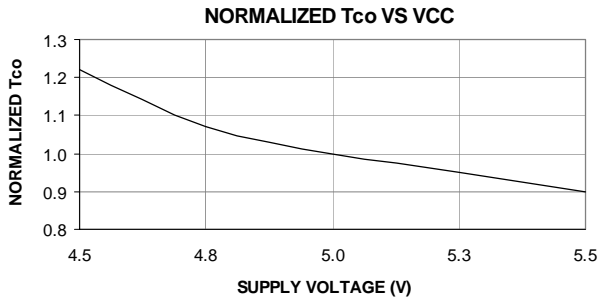
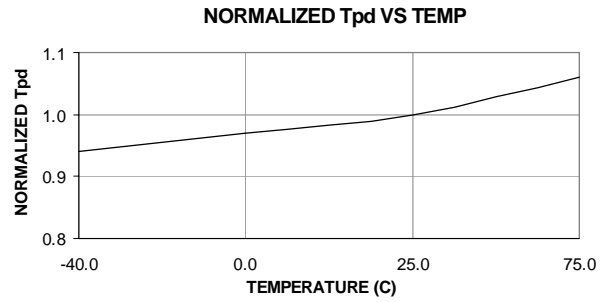
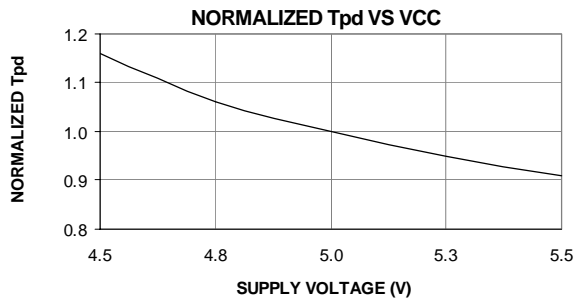
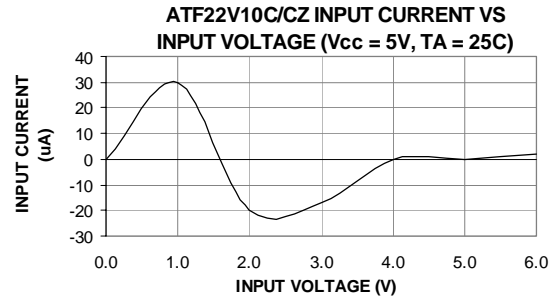
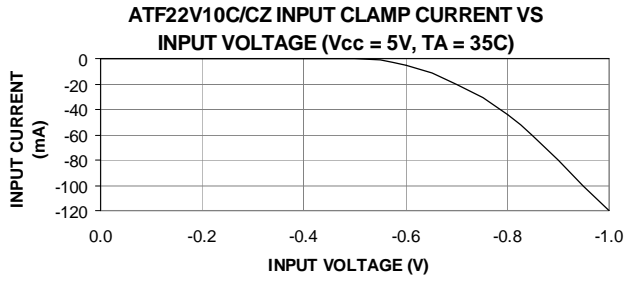

**ATF22V10C DELTA  $T_{PD}$  VS. OUTPUT LOADING**

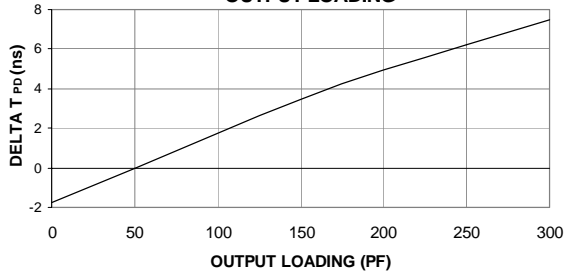

**ATF22V10C DELTA  $T_{CO}$  VS. OUTPUT LOADING**

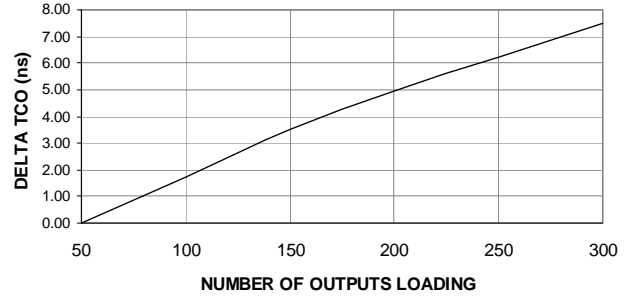

**DELTA  $T_{pd}$  VS # OF OUTPUT SWITCHING**

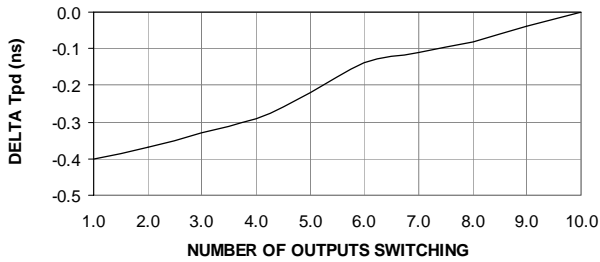

**DELTA  $T_{co}$  VS # OF OUTPUT SWITCHING**

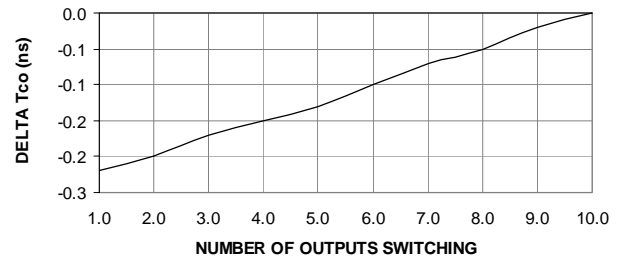

## ATF22V10CZ Ordering Information

t <sub>PD</sub> (ns)	t <sub>S</sub> (ns)	t <sub>CO</sub> (ns)	Ordering Code	Package	Operation Range
12	10	8	ATF22V10CZ-12JC ATF22V10CZ-12PC ATF22V10CZ-12SC ATF22V10CZ-12XC	28J 24P3 24S 24X	Commercial (0°C to 70°C)
15	4.5	8	ATF22V10CZ-15JC ATF22V10CZ-15PC ATF22V10CZ-15SC ATF22V10CZ-15XC	28J 24P3 24S 24X	Commercial (0°C to 70°C)
15	4.5	8	ATF22V10CZ-15JC ATF22V10CZ-15PC ATF22V10CZ-15SC ATF22V10CZ-15XC	28J 24P3 24S 24X	Industrial (-40°C to +85°C)

## Using “C” Product for Industrial

To use commercial product for Industrial temperature ranges, down-grade one speed grade from the “I” to the “C” device (7 ns “C” = 10 ns “I”) and de-rate power by 30%.

Package Type	
<b>28J</b>	28-lead, Plastic J-leaded Chip Carrier (PLCC)
<b>24P3</b>	24-lead, 0.300", Plastic Dual Inline Package (PDIP)
<b>24S</b>	24-lead, 0.300" Wide, Plastic Gull-Wing Small Outline (SOIC)
<b>24X</b>	24-lead, 4.4 mm Wide, Plastic Thin Shrink Small Outline (TSSOP)

## Packaging Information

**28J**, 28-lead, Plastic J-leaded Chip Carrier (PLCC)  
 Dimensions in Inches and (Millimeters)  
 JEDEC STANDARD MS-018 AB

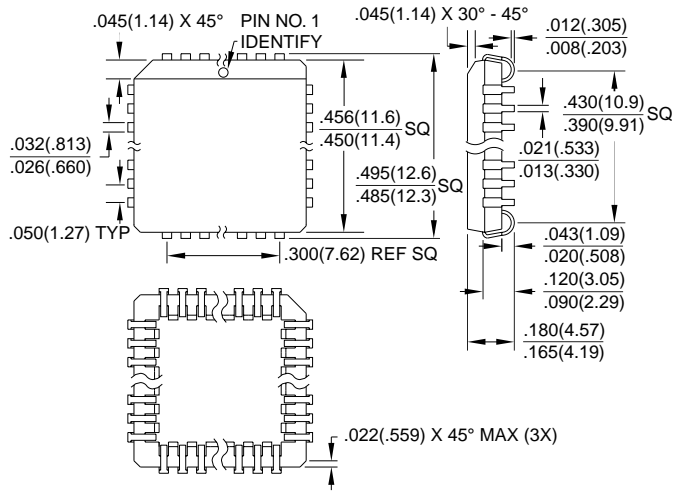

**24P3**, 24-lead, 0.300" Wide,  
 Plastic Dual Inline Package (PDIP)  
 Dimensions in Inches and (Millimeters)  
 JEDEC STANDARD MS-001 AF

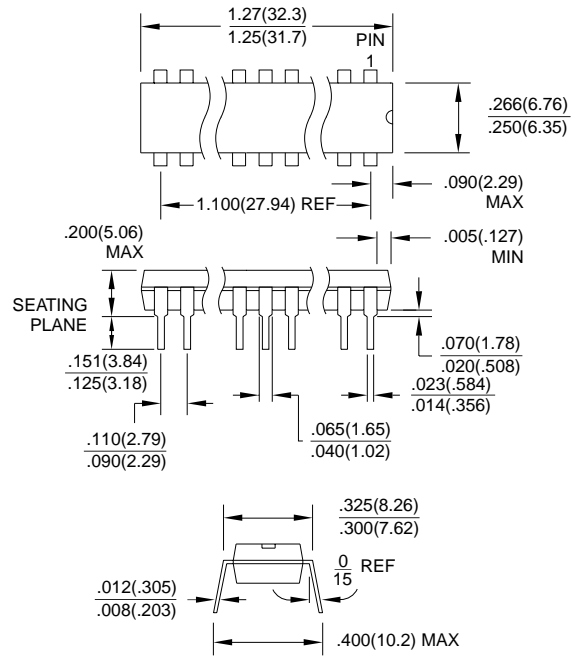

**24S**, 24-lead, 0.300" Wide,  
 Plastic Gull-Wing Small Outline (SOIC)  
 Dimensions in Inches and (Millimeters)

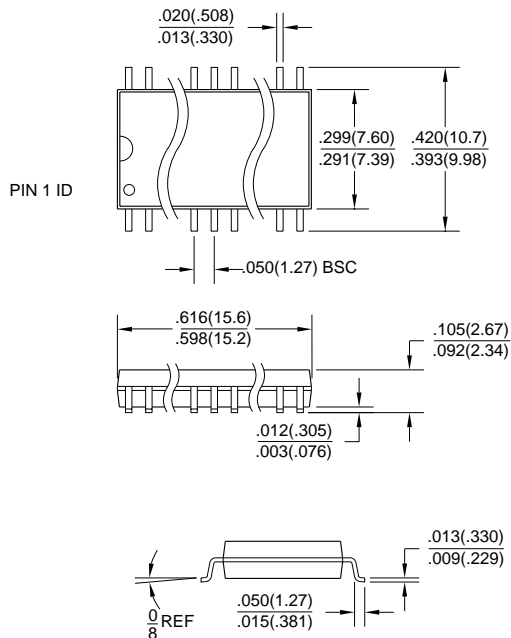

**24X**, 24-lead, 4.4 mm Wide, Plastic Thin Shrink  
 Small Outline (TSSOP)  
 Dimensions in Inches and (Millimeters)

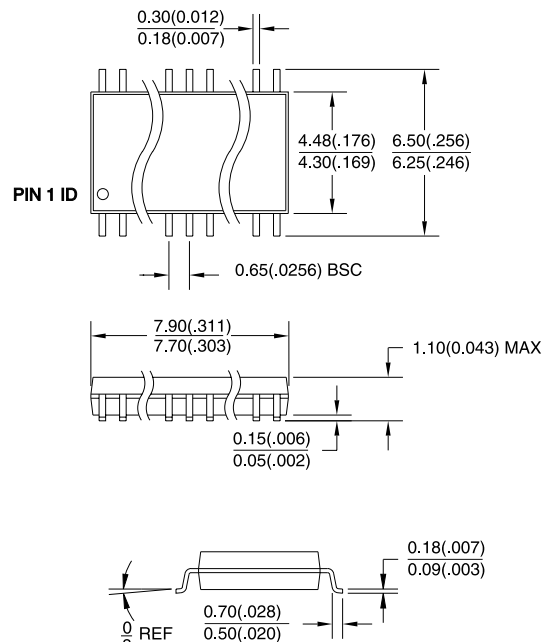



## **Atmel Headquarters**

### ***Corporate Headquarters***

2325 Orchard Parkway  
San Jose, CA 95131  
TEL (408) 441-0311  
FAX (408) 487-2600

### ***Europe***

Atmel U.K., Ltd.  
Coliseum Business Centre  
Riverside Way  
Camberley, Surrey GU15 3YL  
England  
TEL (44) 1276-686-677  
FAX (44) 1276-686-697

### ***Asia***

Atmel Asia, Ltd.  
Room 1219  
Chinachem Golden Plaza  
77 Mody Road Tsimhatsui  
East Kowloon  
Hong Kong  
TEL (852) 2721-9778  
FAX (852) 2722-1369

### ***Japan***

Atmel Japan K.K.  
9F, Tonetsu Shinkawa Bldg.  
1-24-8 Shinkawa  
Chuo-ku, Tokyo 104-0033  
Japan  
TEL (81) 3-3523-3551  
FAX (81) 3-3523-7581

## **Atmel Operations**

### ***Atmel Colorado Springs***

1150 E. Cheyenne Mtn. Blvd.  
Colorado Springs, CO 80906  
TEL (719) 576-3300  
FAX (719) 540-1759

### ***Atmel Rousset***

Zone Industrielle  
13106 Rousset Cedex  
France  
TEL (33) 4-4253-6000  
FAX (33) 4-4253-6001

---

### ***Fax-on-Demand***

North America:  
1-(800) 292-8635  
International:  
1-(408) 441-0732

### ***e-mail***

[literature@atmel.com](mailto:literature@atmel.com)

### ***Web Site***

<http://www.atmel.com>

### ***BBS***

1-(408) 436-4309

#### **© Atmel Corporation 1999.**

Atmel Corporation makes no warranty for the use of its products, other than those expressly contained in the Company's standard warranty which is detailed in Atmel's Terms and Conditions located on the Company's web site. The Company assumes no responsibility for any errors which may appear in this document, reserves the right to change devices or specifications detailed herein at any time without notice, and does not make any commitment to update the information contained herein. No licenses to patents or other intellectual property of Atmel are granted by the Company in connection with the sale of Atmel products, expressly or by implication. Atmel's products are not authorized for use as critical components in life support devices or systems.

Marks bearing ® and/or ™ are registered trademarks and trademarks of Atmel Corporation.

Terms and product names in this document may be trademarks of others.



Printed on recycled paper.

0778E-08/99/xM